

SMBG Plastic-Encapsulate Diodes

1.5SMB SERIES Transient Voltage Suppressor Diodes

Features

- P_{PP} 1500W
- V_{RWM} 5.8V- 150V
- Glass passivated chip

Applications

- Clamping Voltage

Marking

- 1.5SMBXXCA/XXA
XX : From 6.8 To 150

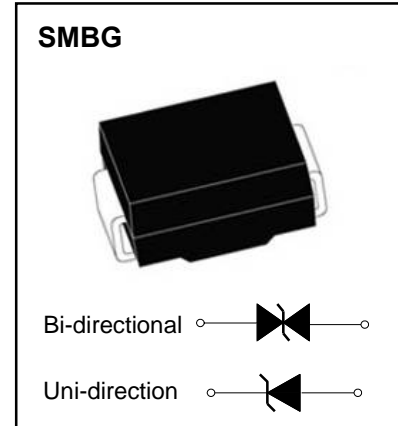

Limiting Values (Absolute Maximum Rating)

Item	Symbol	Unit	Conditions	Max
Peak pulse power dissipation	P_{PPM}	W	with a 10/1000us waveform	1500
Peak pulse current (1)	I_{PPM}	A	with a 10/1000us waveform	See Next Table
Power dissipation	P_D	W	On infinite heat sink at $T_L=75^\circ\text{C}$	6.5
Peak forward surge current(2)	I_{FSM}	A	8.3 ms single half sine-wave unidirectional only	200
Operating junction and storage temperature range	T_J, T_{STG}	$^\circ\text{C}$		-55 to +150

Electrical Characteristics ($T_a=25^\circ\text{C}$ Unless otherwise specified)

Item	Symbol	Unit	Conditions	Max
Maximum instantaneous forward Voltage (3)	V_F	V	at 100A for unidirectional only	3.5/6.5
Thermal resistance	$R_{\theta JL}$	$^\circ\text{C/W}$	junction to lead	15
	$R_{\theta JA}$	$^\circ\text{C/W}$	junction to ambient, $L_{Lead} = 10 \text{ mm}$	75

Notes:

- (1) Non-repetitive current pulse, per Fig. 3 and derated above $T_A = 25^\circ\text{C}$ per Fig.2.
- (2) Mounted on 0.2 x 0.2" (5.0 x 5.0 mm) copper pads to each terminal
- (3) $V_F < 3.5\text{V}$ for devices of $V_{BR} < 200\text{V}$ and $V_F < 5.0\text{V}$ for devices of $V_{BR} > 201\text{V}$

Electrical Characteristics ($T_A=25^\circ\text{C}$ unless otherwise noted)

Part Number		Reverse Stand-off Voltage	Breakdown Voltage $V_{BR} @ I_T$		Test Current	Max. Clamping Voltage @ I_{PP}	Max. Peak Pulse Current	Max. Reverse Leakage @ V_{RWM}
UNI-POLAR	BI-POLAR	$V_{RWM}(V)$	Min.(V)	Max.(V)	$I_T(mA)$	$V_{C MAX}(V)$	$I_{PP}(A)$	$I_R(\mu A)$
1.5SMB6.8A	1.5SMB6.8CA	5.8	6.45	7.14	10	10.5	144.8	1000
1.5SMB7.5A	1.5SMB7.5CA	6.4	7.13	7.88	10	11.3	134.5	500
1.5SMB8.2A	1.5SMB8.2CA	7.0	7.79	8.61	10	12.1	125.6	200
1.5SMB9.1A	1.5SMB9.1CA	7.8	8.65	9.55	1	13.4	113.4	50
1.5SMB10A	1.5SMB10CA	8.6	9.50	10.50	1	14.5	104.8	10
1.5SMB11A	1.5SMB11CA	9.4	10.50	11.60	1	15.6	97.4	5
1.5SMB12A	1.5SMB12CA	10.2	11.40	12.60	1	16.7	91.0	5
1.5SMB13A	1.5SMB13CA	11.1	12.40	13.70	1	18.2	83.5	1
1.5SMB15A	1.5SMB15CA	12.8	14.30	15.80	1	21.2	71.7	1
1.5SMB16A	1.5SMB16CA	13.6	15.20	16.80	1	22.5	67.6	1
1.5SMB18A	1.5SMB18CA	15.3	17.10	18.90	1	25.5	60.3	1
1.5SMB20A	1.5SMB20CA	17.1	19.00	21.00	1	27.7	54.9	1
1.5SMB22A	1.5SMB22CA	18.8	20.90	23.10	1	30.6	49.7	1
1.5SMB24A	1.5SMB24CA	20.5	22.80	25.20	1	33.2	45.8	1
1.5SMB27A	1.5SMB27CA	23.1	25.70	28.40	1	37.5	40.5	1
1.5SMB30A	1.5SMB30CA	25.6	28.50	31.50	1	41.4	36.7	1
1.5SMB33A	1.5SMB33CA	28.2	31.40	34.70	1	45.7	33.3	1
1.5SMB36A	1.5SMB36CA	30.8	34.20	37.80	1	49.9	30.5	1
1.5SMB39A	1.5SMB39CA	33.3	37.10	41.00	1	53.9	28.2	1
1.5SMB43A	1.5SMB43CA	36.8	40.90	45.20	1	59.3	25.6	1
1.5SMB47A	1.5SMB47CA	40.2	44.70	49.40	1	64.8	23.5	1
1.5SMB51A	1.5SMB51CA	43.6	48.50	53.60	1	70.1	21.7	1
1.5SMB56A	1.5SMB56CA	47.8	53.20	58.80	1	77.0	19.7	1
1.5SMB62A	1.5SMB62CA	53.0	58.90	65.10	1	85.0	17.9	1
1.5SMB68A	1.5SMB68CA	58.1	64.60	71.40	1	92.0	16.5	1
1.5SMB75A	1.5SMB75CA	64.1	71.30	78.80	1	103.0	14.8	1
1.5SMB82A	1.5SMB82CA	70.1	77.90	86.10	1	113.0	13.5	1
1.5SMB91A	1.5SMB91CA	77.8	86.50	95.50	1	125.0	12.2	1
1.5SMB100A	1.5SMB100CA	85.5	95.0	105.0	1	137.0	11.1	1
1.5SMB110A	1.5SMB110CA	94.0	105.0	116.0	1	152.0	10	1
1.5SMB120A	1.5SMB120CA	102.0	114.0	126.0	1	165.0	9.2	1
1.5SMB130A	1.5SMB130CA	111.0	124.0	137.0	1	179.0	8.5	1
1.5SMB150A	1.5SMB150CA	128.0	143.0	158.0	1	207.0	7.3	1

Typical Characteristics

FIG1: Peak Pulse Power Rating Curve

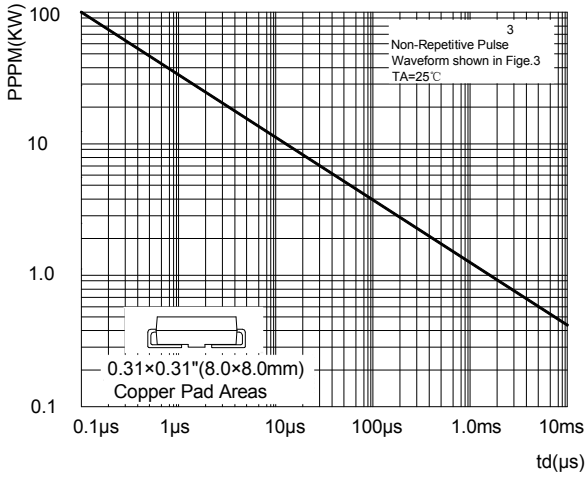

FIG2: Pulse Power or Current vs. Initial Junction Temperature

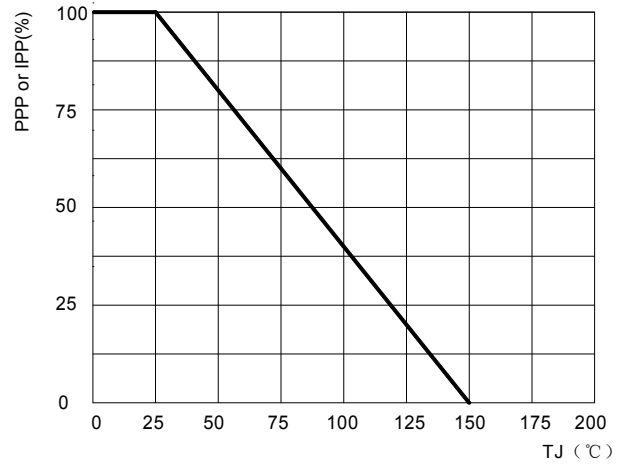

FIG3: Pulse Waveform

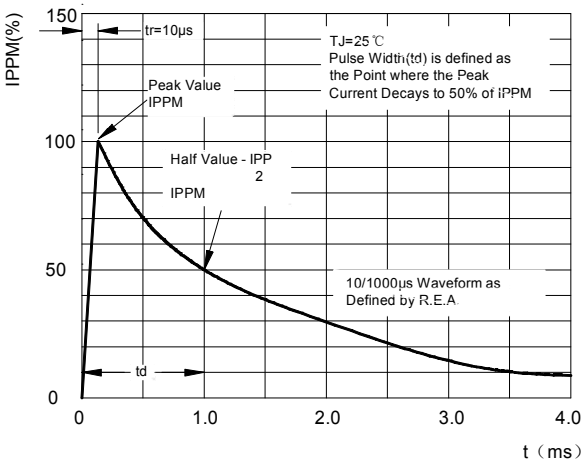

FIG4: Typical Transient Thermal Impedance

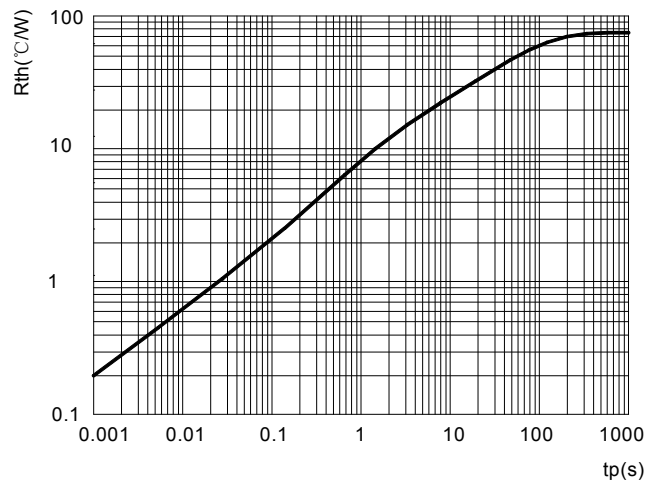

FIG5: Maximum Non-Repetitive Surge Current

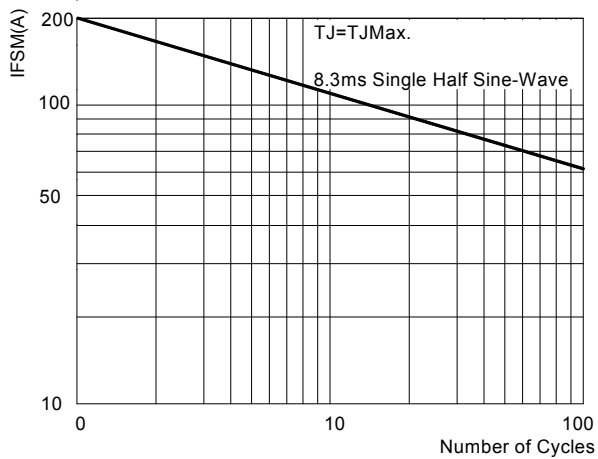
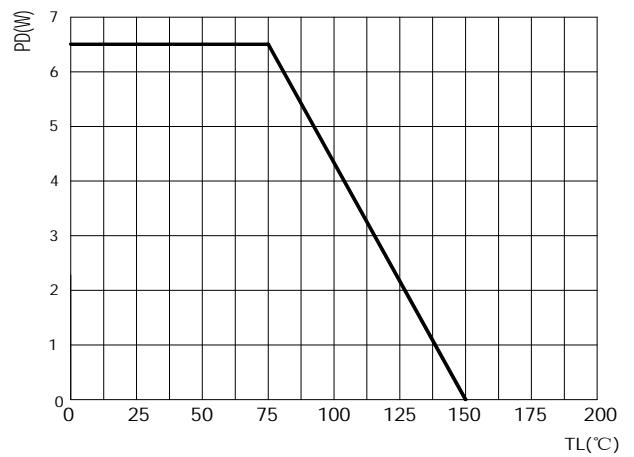
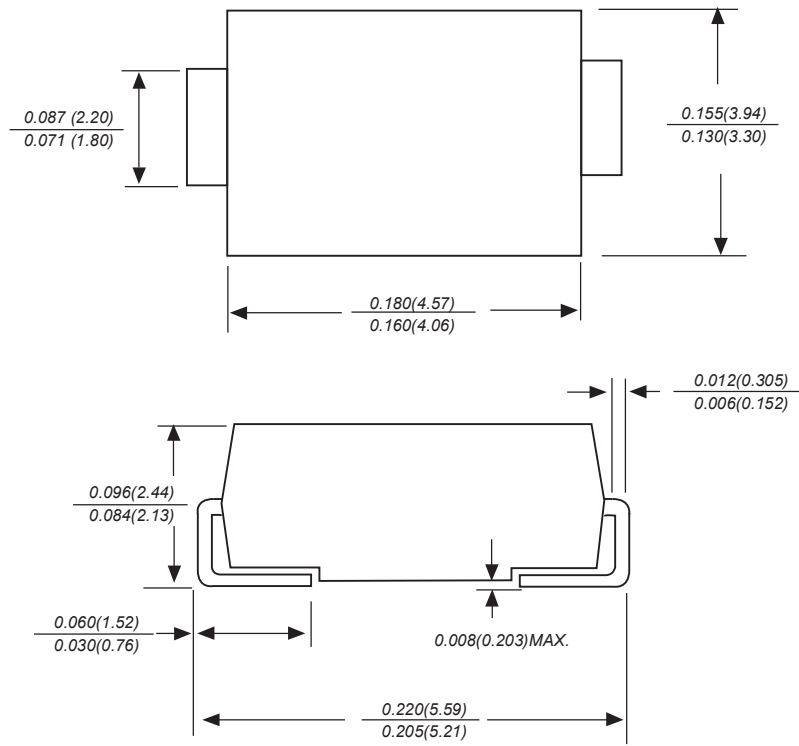

FIG6: Steady State Power Dissipation



SMBG Package Outline Dimensions



Dimensions in inches and (millimeters)

SMBG Suggested Pad Layout

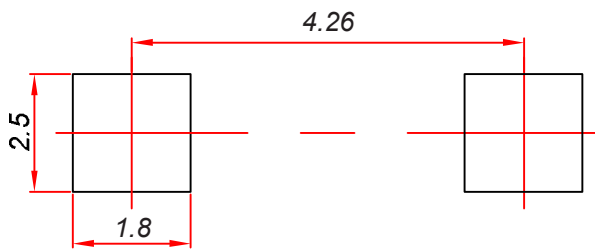

Note:

1. Controlling dimension: in millimeters.
2. General tolerance: $\pm 0.05 \text{ mm}$.
3. The pad layout is for reference purposes only.

NOTICE

JSCJ reserves the right to make modifications, enhancements, improvements, corrections or other changes without further notice to any product herein. JSCJ does not assume any liability arising out of the application or use of any product described herein.

Reel Taping Specifications For Surface Mount Devices- SMBG

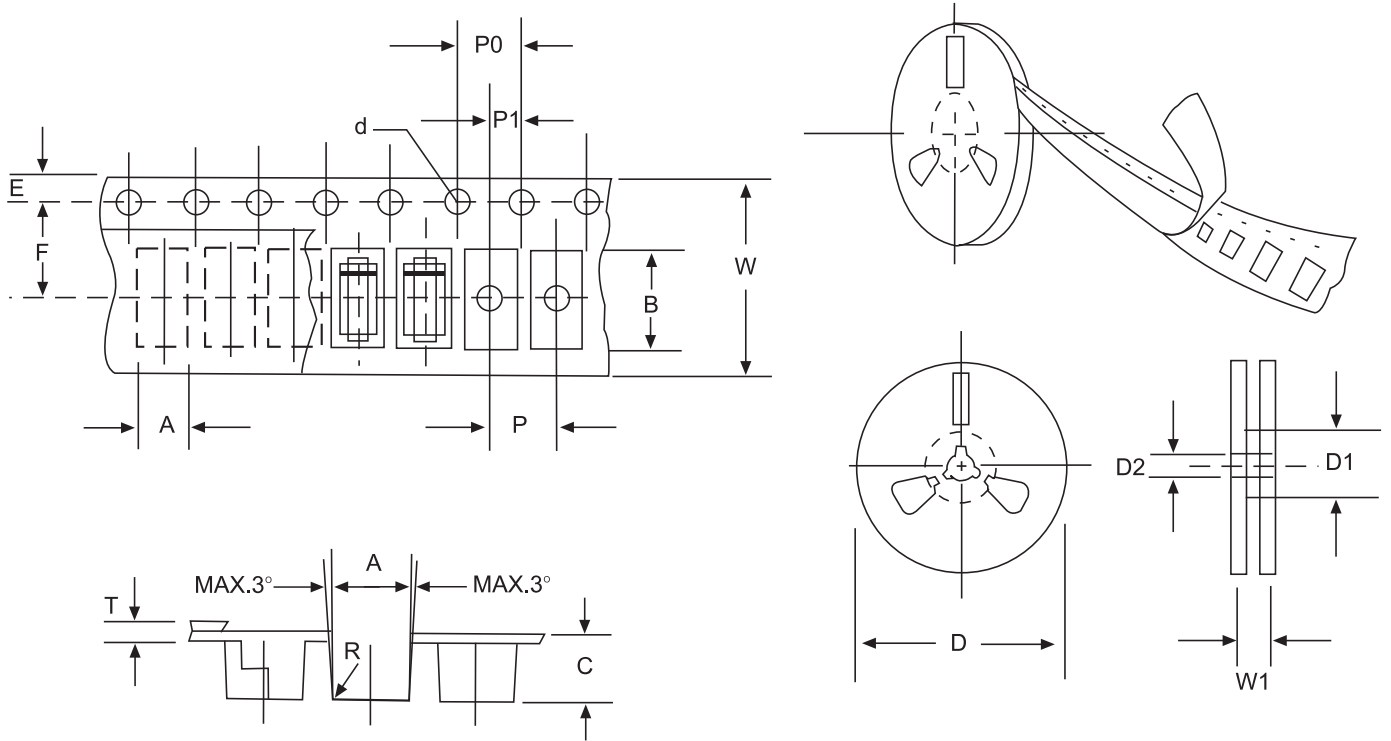

FIG: CONFIGURATION OF SURFACE MOUNTED DEVICES TAPING

ITEM	SYMBOL	SMBG mm(inch)
Carrier width	A	4.09±0.1(0.161±0.004)
Carrier length	B	5.82±0.1(0.229±0.004)
Carrier depth	C	2.50±0.1(0.100±0.004)
Sprocket hole	d	1.55±0.05(0.061±0.002)
Reel outside diameter	D	330±2.0(13±0.079)
Reel inner diameter	D1	75 ±1.0 (2.95 ±0.039)
Feed hole diameter	D2	13±0.5(0.512±0.020)
Sprocket hole position	E	1.75 ±0.1(0.069±0.004)
Punch hole position	F	5.65±0.05(0.222±0.002)
Punch hole pitch	P	8.0±0.1(0.315±0.004)
Sprocket hole pitch	P0	4.0±0.1(0.157±0.004)
Embossment center	P1	2.0±0.1(0.079±0.004)
Total tape thickness	T	0.32±0.1(0.013±0.004)
Tape width	W	12.0±0.2(0.472±0.008)
Reel width	W1	16.8±2.0(0.661±0.079)

NOTE: Devices are packed in accordance with EIA standard RS-481-A and specification given above.