



SOT-23 Plastic-Encapsulate MOSFET

2N7002KA N-Channel MOSFET

Key Performance Parameters

$V_{BR(DSS)}$	$R_{DS(on)TYP}$	I_D
60V	0.73Ω@10V	0.5A
	0.80Ω@4.5V	

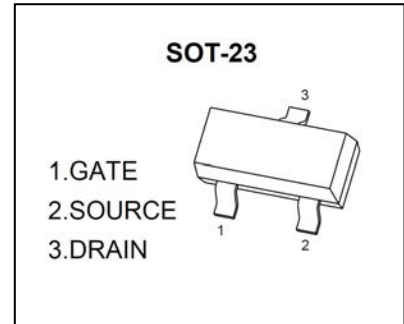

DESCRIPTION

This advanced technology has been especially tailored to minimize on-state resistance, provide superior switching performance.

FEATURES

- High density cell design for Low $R_{DS(on)}$
- Voltage controlled small signal switch
- Rugged and reliable
- High saturation current capability
- ESD protected

APPLICATIONS

- Load Switch for Portable Devices
- DC/DC Converter

MARKING

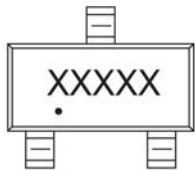

XXXXX = 72KA
Solid dot = Green molding compound device.

EQUIVALENT CIRCUIT

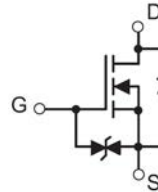

ABSOLUTE MAXIMUM RATINGS ($T_J=25^{\circ}C$ unless otherwise specified)

Parameter		Symbol	Value	Unit
Drain-Source Voltage		V_{DS}	60	V
Gate-Source Voltage		V_{GS}	±20	V
Continuous Drain Current	$T_A = 25^{\circ}C$	$I_D^{(5)}$	0.5	A
	$T_A = 75^{\circ}C$		0.4	
Pulsed Drain Current		$I_{DM}^{(1)(2)}$	2	A
Power Dissipation		$P_D^{(1)(3)}$	0.6	W
Operating Junction and Storage Temperature Range		T_J, T_{stg}	-55~+150	°C

Thermal Characteristics

Parameter		Symbol	Value		Unit
			Typ	Max	
Thermal Resistance from Junction to Ambient	t≤10s	$R_{\theta JA}^{(5)}$	160	200	°C/W
	Steady State		190	240	°C/W

Typical Characteristics

ELECTRICAL CHARACTERISTICS ($T_J=25^\circ\text{C}$ unless otherwise specified)

Static Characteristics

Parameter	Symbol	Test Condition	Value			Unit	
			Min	Typ	Max		
Drain-source breakdown voltage	$V_{(BR)DSS}$	$V_{GS}=0V, I_D=250\mu A$	60	-	-	V	
Zero gate voltage drain current	I_{DSS}	$V_{DS}=60V, V_{GS}=0V$	$T_J=25^\circ\text{C}$	-	-	1.0	μA
			$T_J=125^\circ\text{C}$	-	-	100	
Gate-body leakage current	I_{GSS}	$V_{GS}=\pm 20V, V_{DS}=0V$	-	-	± 10	μA	
Gate-threshold voltage	$V_{GS(th)}$	$V_{DS}=V_{GS}, I_D=250\mu A$	1.0	1.5	2.0	V	
Static drain-source on-state resistance	$R_{DS(on)}^{(3)}$	$V_{GS}=10V, I_D=500mA$	$T_J=25^\circ\text{C}$	-	0.73	1.2	Ω
			$T_J=125^\circ\text{C}$	-	1.28	2.2	
		$V_{GS}=4.5V, I_D=200mA$	-	0.80	1.5		
Forward transconductance	g_{FS}	$V_{DS}=3V, I_D=500mA$	-	1	-	S	

Dynamic Characteristics⁽⁴⁾

Input capacitance	C_{iss}	$V_{GS}=0V, V_{DS}=30V,$ $f=1MHz$	-	37	-	μF
Output capacitance	C_{oss}		-	11	-	
Reverse transfer capacitance	C_{rss}		-	5.2	-	
Total gate charge	Q_g	$V_{GS}=4.5V, V_{DS}=30V, I_D=500mA$	-	0.61	-	nC
Gate charge at threshold	$Q_{G(th)}$	$V_{GS}=10V, V_{DS}=30V, I_D=500mA$	-	1.04	-	
Gate-source charge	Q_{gs}		-	0.10	-	
Gate-drain charge	Q_{gd}		-	0.18	-	
Turn-on delay time	$t_{d(on)}$	$V_{DD}=30V, V_{GS}=10V,$ $R_L=250\Omega, R_g=50\Omega$	-	0.31	-	ns
Turn-on rise time	t_r		-	6.0	-	
Turn-off delay time	$t_{d(off)}$		-	5.1	-	
Turn-off fall time	t_f		-	54	-	
			-	37	-	

Reverse Diode Characteristics

Drain-source diode forward voltage	$V_{SD}^{(3)}$	$V_{GS}=0V, I_S=300mA$	-	-	1.2	V
Continuous drain-source diode forward current	$I_S^{(1)}$		-	-	0.5	A
Pulsed drain-source diode forward current	$I_{SM}^{(1)(2)}$		-	-	2	A

Notes:

- ①.Limited only by maximum temperature allowed.
- ②. $P_w \leq 10\mu s$, Duty cycle $\leq 1\%$.
- ③.Pulse Test : Pulse Width $\leq 380\mu s$, duty cycle $\leq 2\%$.
- ④.Guaranteed by design, not subject to production.
- ⑤.Device mounted on 1 in² FR-4 board with 2oz. double-sided Copper, in a still air environment with $T_A=25^\circ\text{C}$. The current rating is based on the $t \leq 10s$ thermal resistance rating.

Typical Characteristics

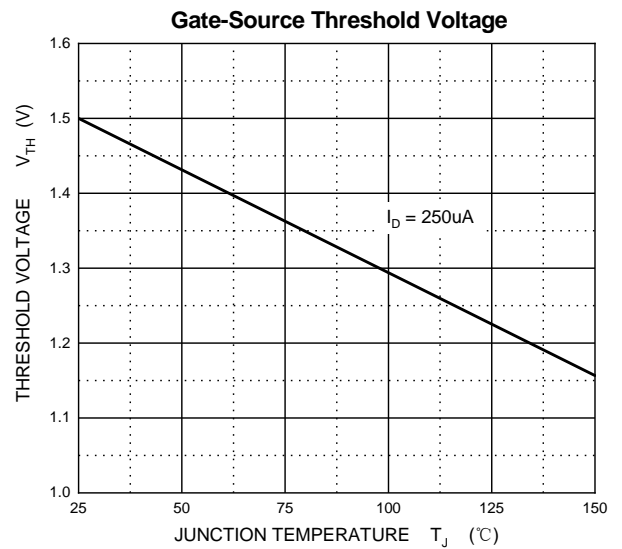
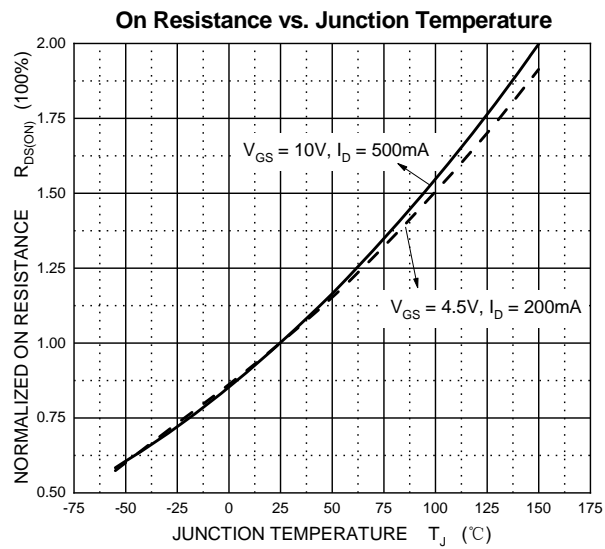
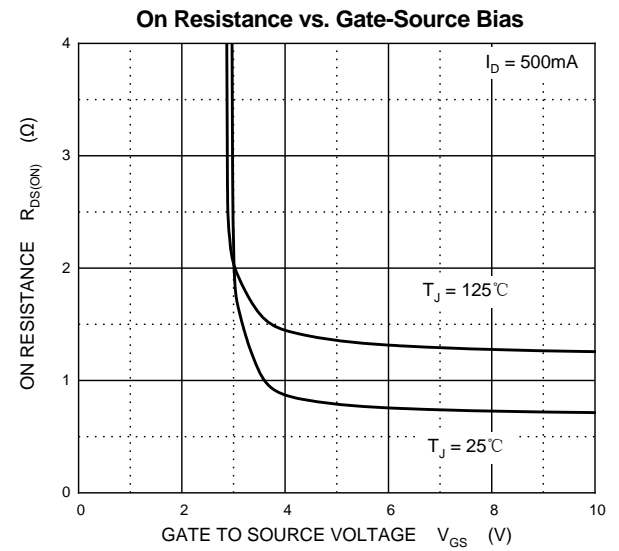
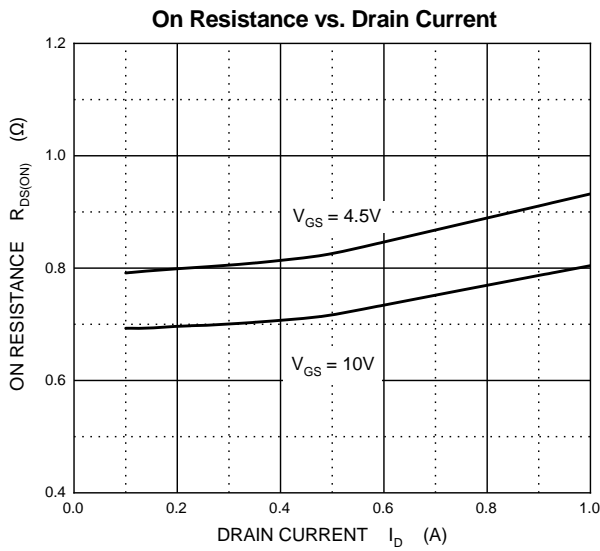
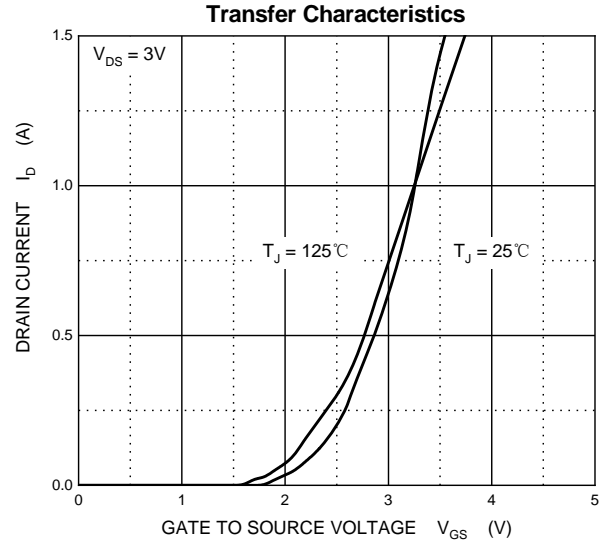
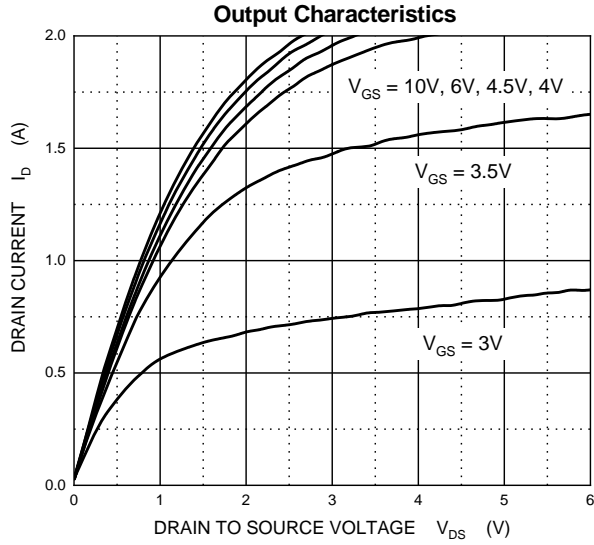

Typical Characteristics

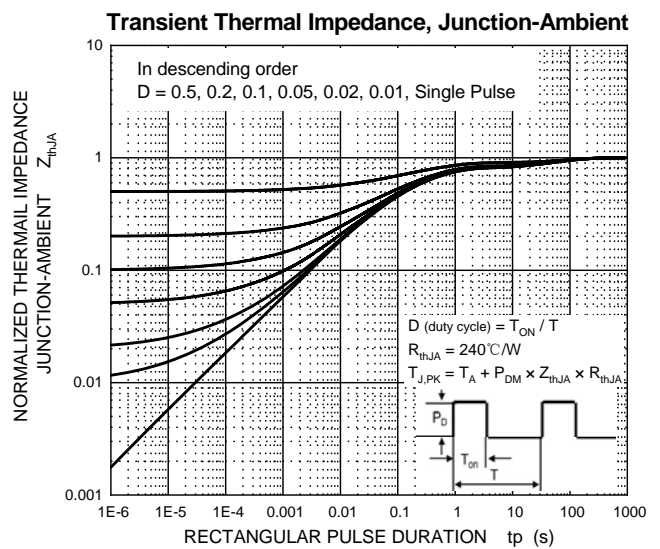
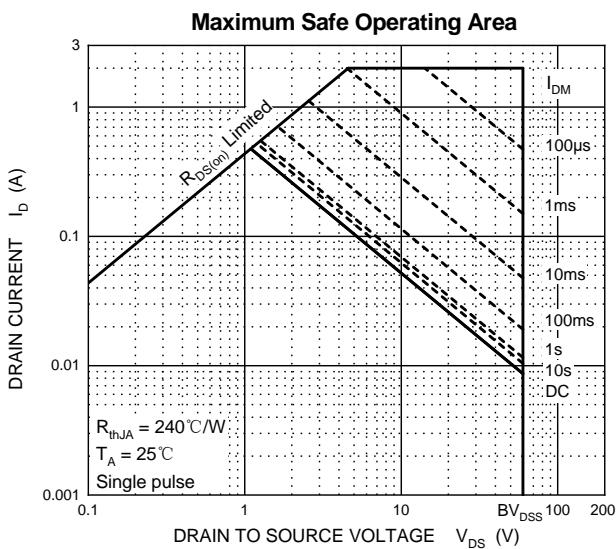
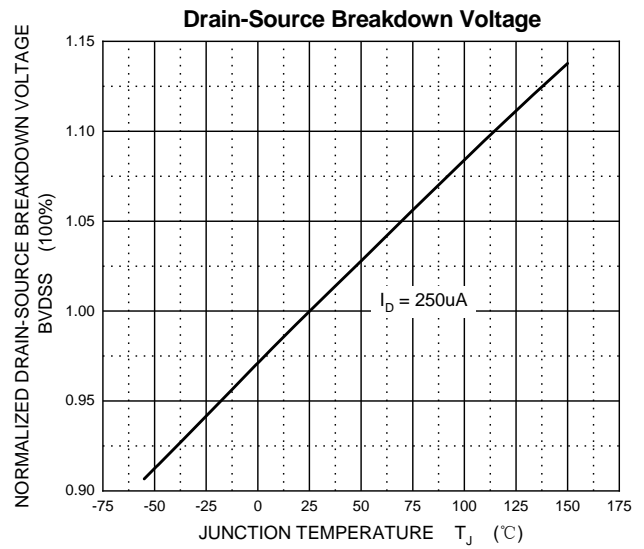
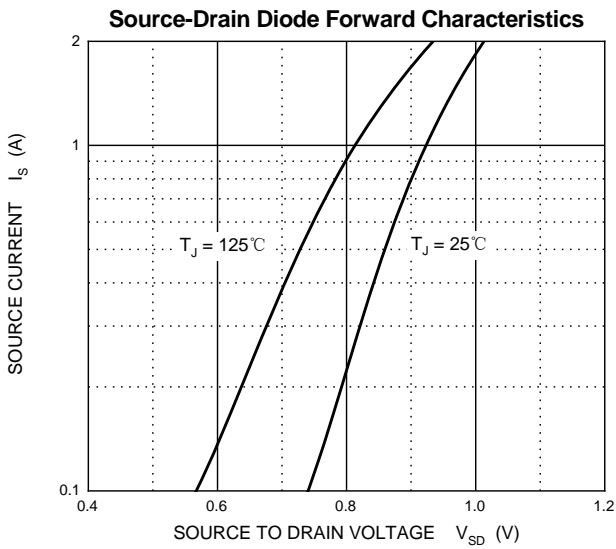
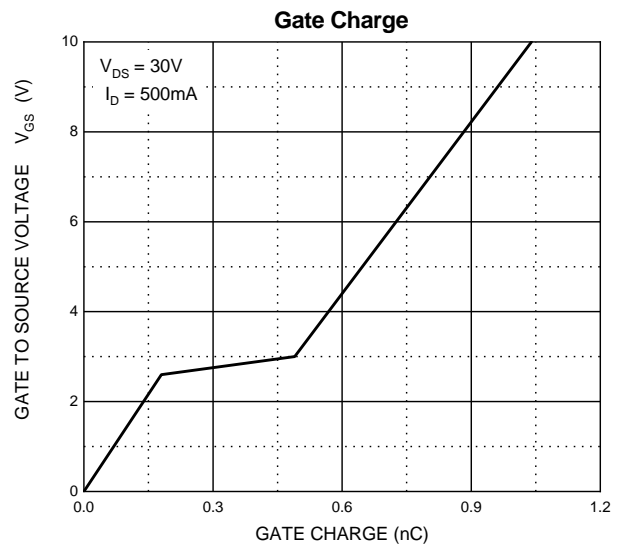
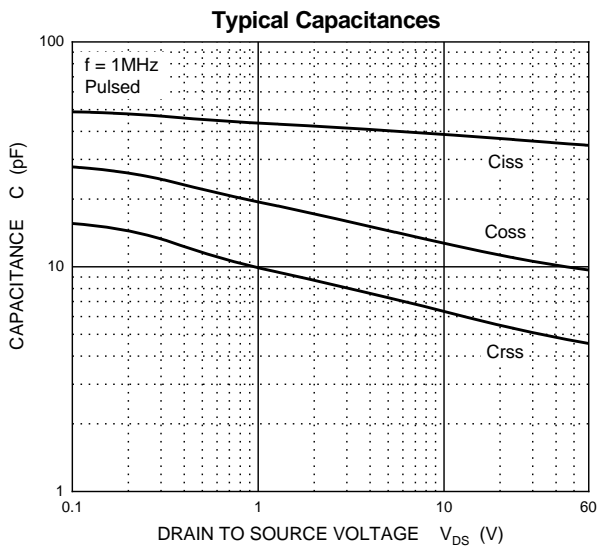

SOT-23 Package Outline Dimensions

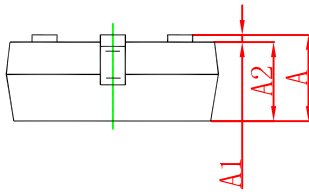
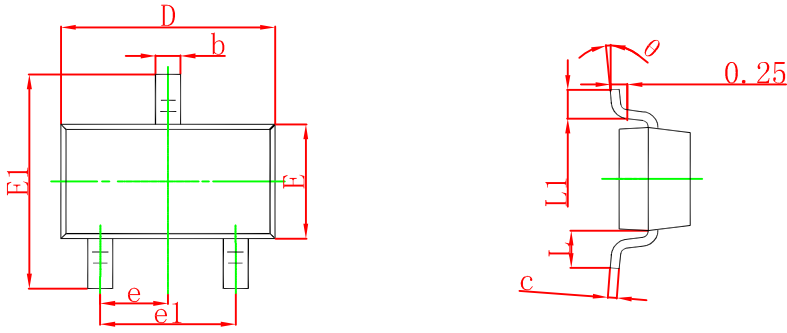

Symbol	Dimensions In Millimeters		Dimensions In Inches	
	Min	Max	Min	Max
A	0.900	1.150	0.035	0.045
A1	0.000	0.100	0.000	0.004
A2	0.900	1.050	0.035	0.041
b	0.300	0.500	0.012	0.020
c	0.080	0.150	0.003	0.006
D	2.800	3.000	0.110	0.118
E	1.200	1.400	0.047	0.055
E1	2.250	2.550	0.089	0.100
e	0.950 TYP		0.037 TYP	
e1	1.800	2.000	0.071	0.079
L	0.550 REF		0.022 REF	
L1	0.300	0.500	0.012	0.020
θ	0°	8°	0°	8°

SOT-23 Suggested Pad Layout

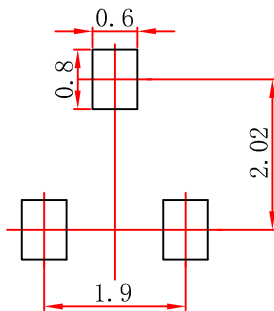

Note:

1. Controlling dimension: in millimeters.
2. General tolerance: $\pm 0.05\text{mm}$.
3. The pad layout is for reference purposes only.

NOTICE

JSCJ reserves the right to make modifications, enhancements, improvements, corrections or other changes without further notice to any product herein. JSCJ does not assume any liability arising out of the application or use of any product described herein.

SOT-23 Tape and Reel

SOT-23 Embossed Carrier Tape

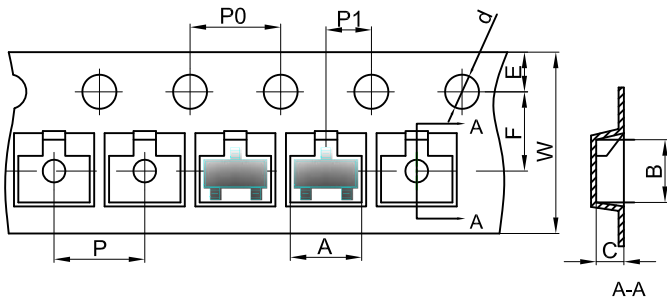

Packaging Description:

SOT-23 parts are shipped in tape. The carrier tape is made from a dissipative (carbon filled) polycarbonate resin. The cover tape is a multilayer film (Heat Activated Adhesive in nature) primarily composed of polyester film, adhesive layer, sealant, and anti-static sprayed agent. These reeled parts in standard option are shipped with 3,000 units per 7" or 17.8cm diameter reel. The reels are clear in color and is made of polystyrene plastic (anti-static coated).

Dimensions are in millimeter

Pkg type	A	B	C	d	E	F	P0	P	P1	W
SOT-23	3.15	2.77	1.22	Ø1.50	1.75	3.50	4.00	4.00	2.00	8.00

SOT-23 Tape Leader and Trailer

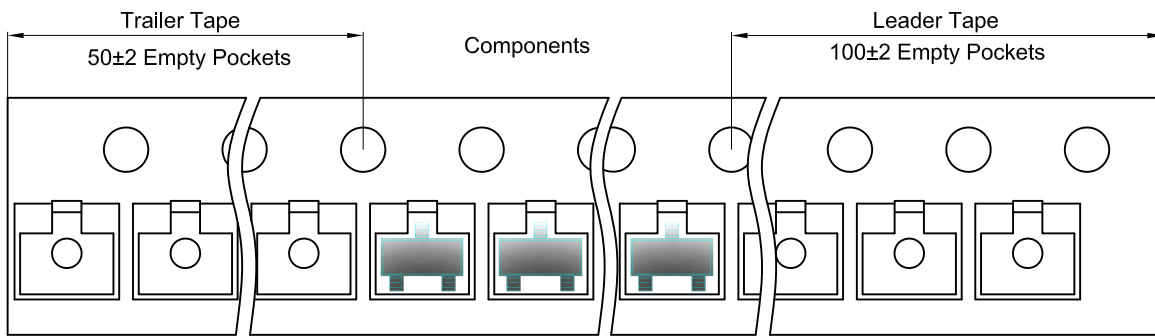

SOT-23 Reel

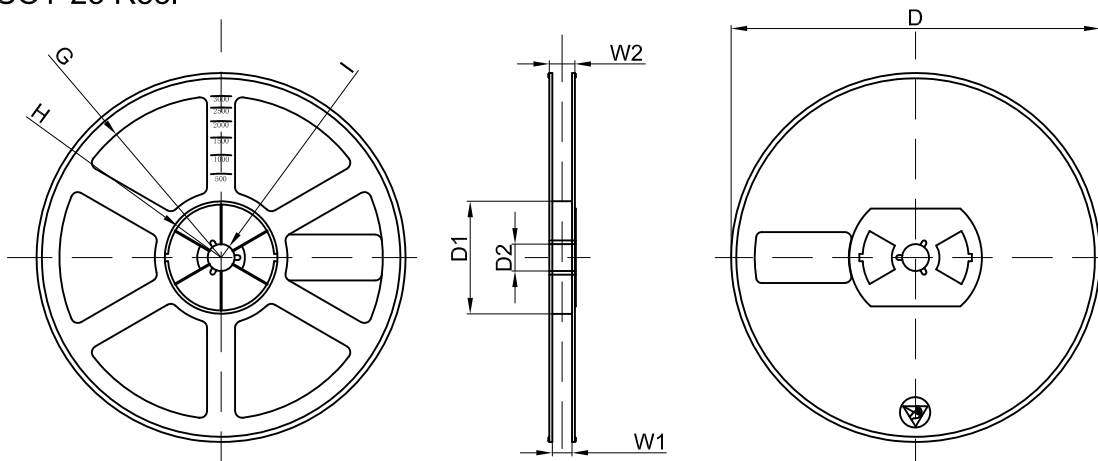

Dimensions are in millimeter

Reel Option	D	D1	D2	G	H	I	W1	W2
7"Dia	Ø178.00	54.40	13.00	R78.00	R25.60	R6.50	9.50	12.30

REEL	Reel Size	Box	Box Size(mm)	Carton	Carton Size(mm)	G.W.(kg)
3000 pcs	7 inch	45,000 pcs	203×203×195	180,000 pcs	438×438×220	