

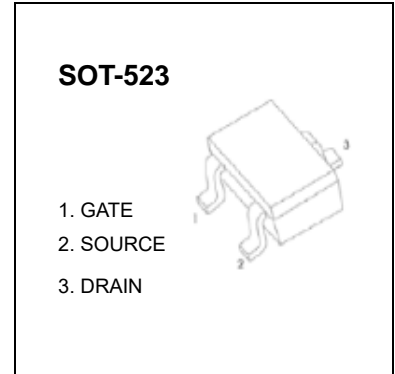

## SOT-523 Plastic-Encapsulate MOSFETS

### 2SK3019S N-channel MOSFET

$V_{(BR)DSS}$	$R_{DS(on)TYP}$	$I_D$
30V	0.19Ω@4V	500mA
	0.72Ω@2.5V	



#### FEATURE

- Low on-resistance
- Fast switching speed
- Low voltage drive makes this device ideal for Portable equipment
- Easily designed drive circuits
- Easy to parallel

#### APPLICATION

- Interfacing , Switching

#### MARKING

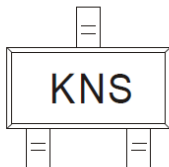

#### Equivalent Circuit

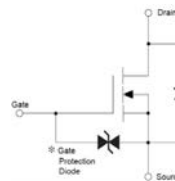

#### MOSFET MAXIMUM RATINGS ( $T_a = 25^\circ\text{C}$ unless otherwise noted)

Symbol	Parameter	Value	Unit
$V_{DS}$	Drain-Source voltage	30	V
$V_{GS}$	Gate-Source Voltage	±20	V
$I_D^{①}$	Continuous Drain Current	0.5	A
$I_{DM}^{①②}$	Pulsed Drain Current ( $t_p=10\mu\text{s}$ )	2	A
$R_{\theta JA}^{⑤}$	Thermal Resistance, Junction-to-Ambient	500	$^\circ\text{C}/\text{W}$
$P_D^{⑤}$	Power Dissipation	0.25	W
$T_J, T_{stg}$	Operation Junction and Storage Temperature Range	-55~+150	$^\circ\text{C}$

# MOSFET ELECTRICAL CHARACTERISTICS

$T_J=25^{\circ}\text{C}$  unless otherwise specified

Parameter	Symbol	Test Condition	Min	Typ	Max	Unit
<b>Off characteristics</b>						
Drain-source breakdown voltage	$V_{(BR)DSS}$	$V_{GS} = 0V, I_D = 10\mu A$	30			V
Zero gate voltage drain current	$I_{DSS}$	$V_{DS}=20V, V_{GS}=0V$			1.0	$\mu A$
Gate-body leakage current	$I_{GSS}$	$V_{DS} = 0V, V_{GS} = \pm 20V$			$\pm 2$	$\mu A$
<b>On characteristics</b> <sup>③</sup>						
Gate-threshold voltage	$V_{GS(th)}$	$V_{DS} = 3V, I_D = 250\mu A$	0.8	1.1	1.5	V
Static drain-source on-resistance	$R_{DS(on)}$	$V_{GS} = 4V, I_D = 10mA$		0.19	0.4	$\Omega$
		$V_{GS} = 2.5V, I_D = 1mA$		0.72	2.0	
Forward Transconductance	$g_{FS}$	$V_{DS} = 3V, I_D = 10mA$		49		mS
<b>Dynamic characteristics</b> <sup>④</sup>						
Input capacitance	$C_{iss}$	$V_{DS} = 5V, V_{GS} = 0V, f = 1MHz$		57		$\mu F$
Output capacitance	$C_{oss}$			20		
Reverse transfer capacitance	$C_{rss}$			11		
Gate resistance	$R_g$	$f = 1MHz$		1020		$\Omega$
<b>Switching characteristics</b> <sup>④</sup>						
Total gate charge	$Q_g$	$V_{DS} = 5V, V_{GS} = 5V, I_D = 1A$		0.65		nC
Gate-source charge	$Q_{gs}$			0.2		
Gate-drain charge	$Q_{gd}$			0.47		
Turn-on delay time	$t_{d(on)}$	$V_{DD} = 5V, V_{GS} = 5V,$ $R_G = 10\Omega, R_L = 500\Omega$		24		ns
Turn-on rise time	$t_r$			28		
Turn-off delay time	$t_{d(off)}$			154		
Turn-off fall time	$t_f$			96		
<b>Drain-Source Diode Characteristics</b>						
Drain-source diode forward voltage	$V_{SD}$ <sup>③</sup>	$V_{GS} = 0V, I_S = 10mA$			1	V
Maximum continuous drain-source diode forward current	$I_S$ <sup>①</sup>				0.5	A
Maximum pulsed drain-source diode forward current	$I_{SM}$ <sup>①②</sup>				2	A

## Notes :

- $T_A = 25^{\circ}\text{C}$ .
- $P_W \leq 10\mu s$ , Duty cycle  $\leq 1\%$ .
- Pulse Test : Pulse Width  $\leq 300\mu s$ , duty cycle  $\leq 2\%$ .
- Guaranteed by design, not subject to production.
- The value of  $R_{\theta JA}$  is measured with the device mounted on 1 in<sup>2</sup> FR-4 board in a still air environment with  $T_a = 25^{\circ}\text{C}$ .

# Typical Characteristics ( $T_J = 25^\circ\text{C}$ , unless otherwise specified)

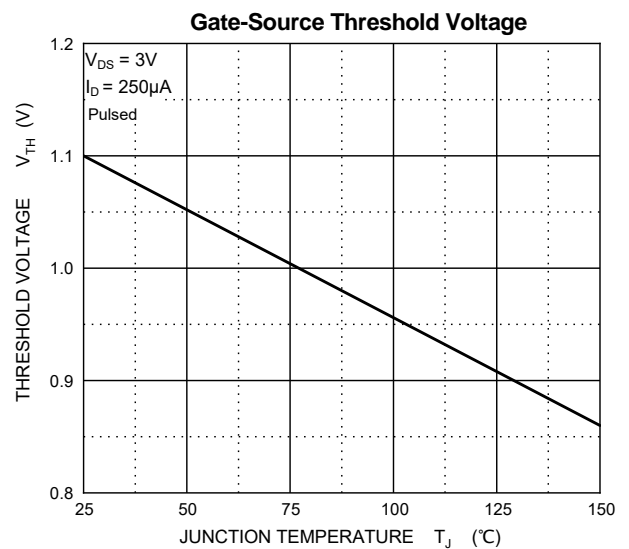
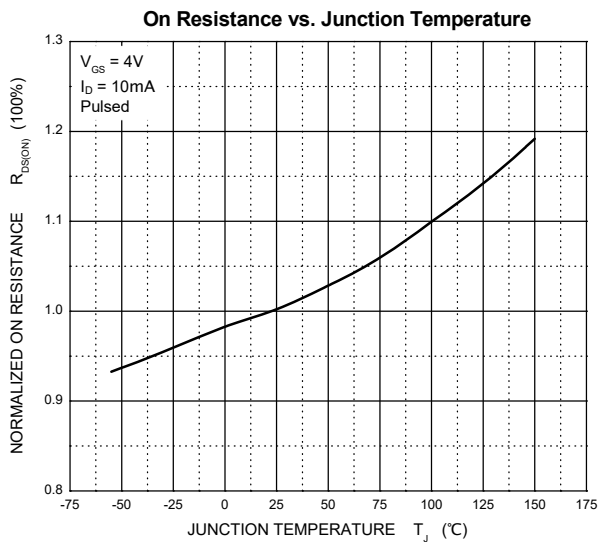
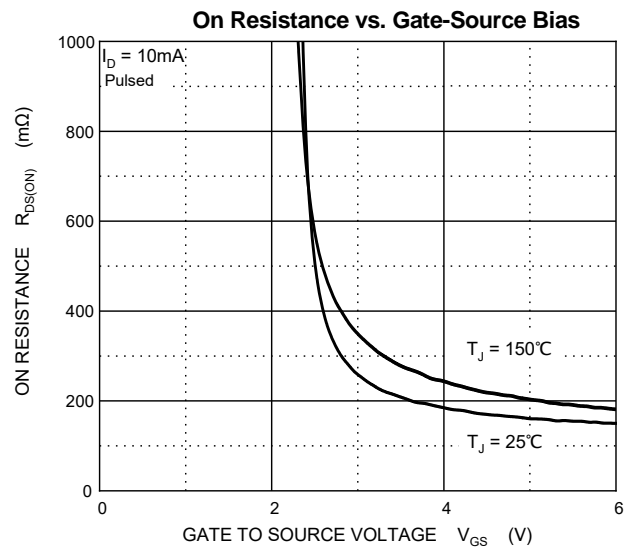
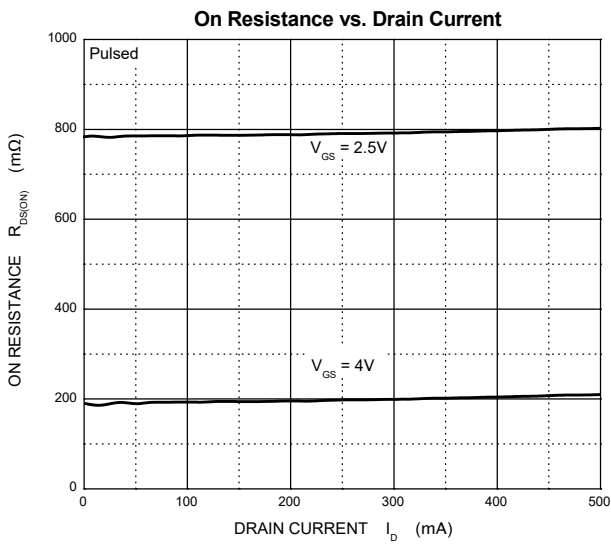
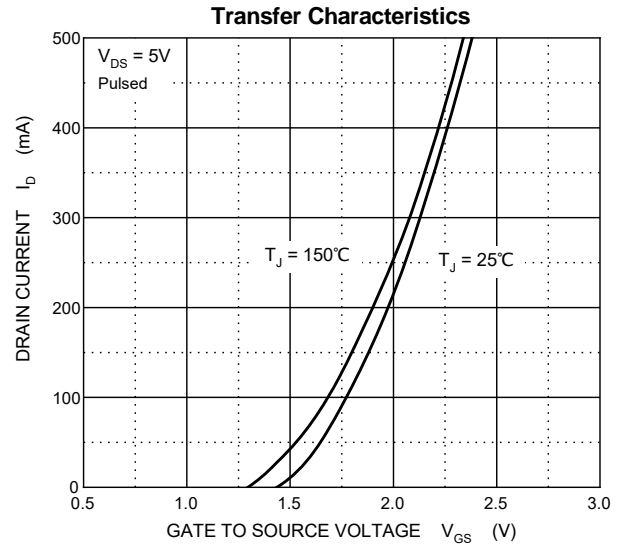
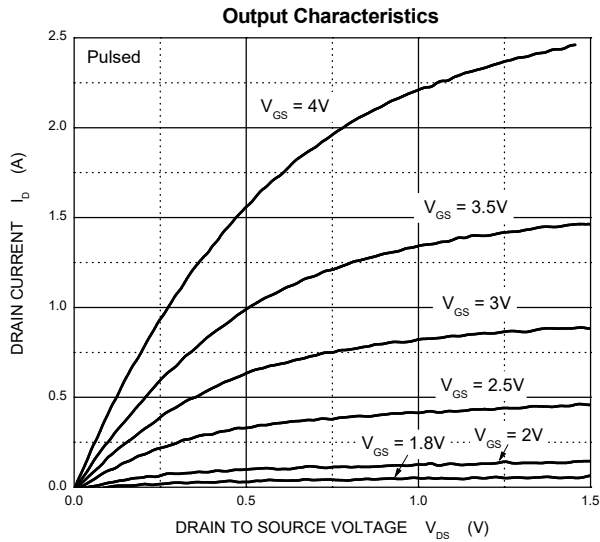

# Typical Characteristics ( $T_J = 25^\circ\text{C}$ , unless otherwise specified)

### Typical Capacitances

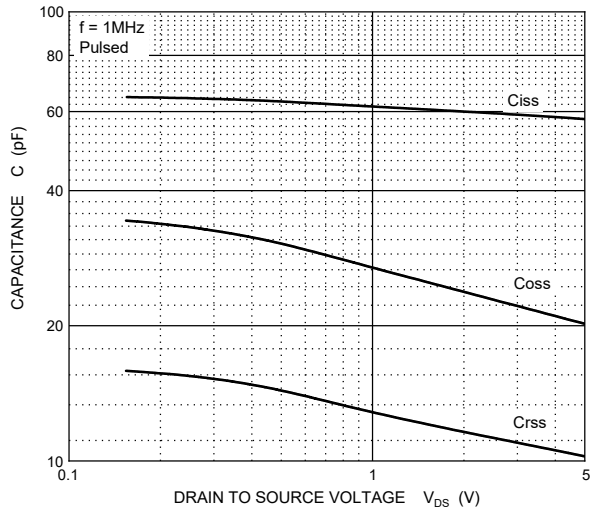

### Gate Charge

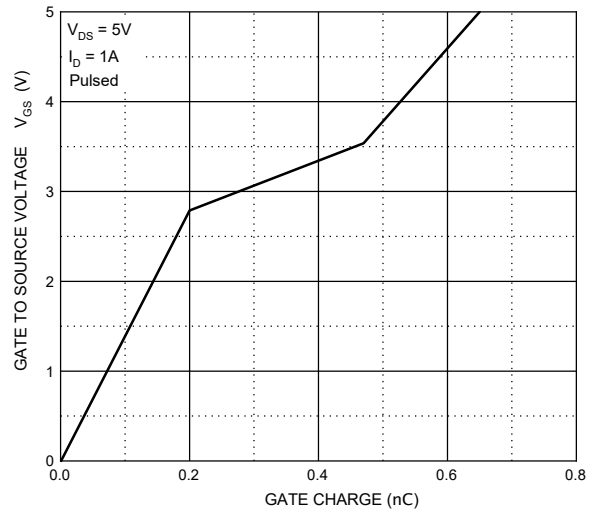

### Source-Drain Diode Forward Characteristics

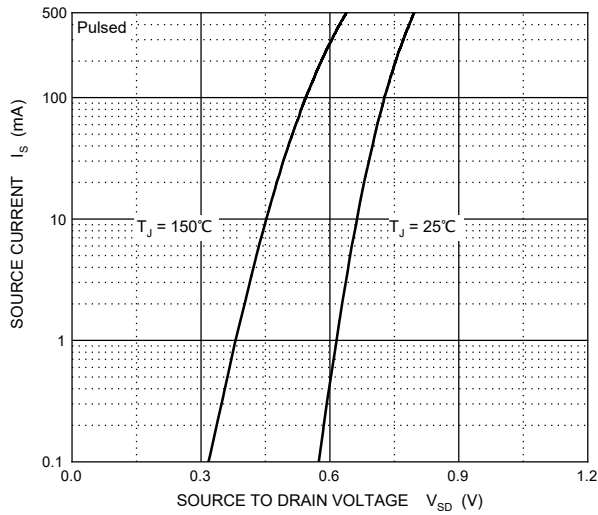

### Maximum Safe Operating Area

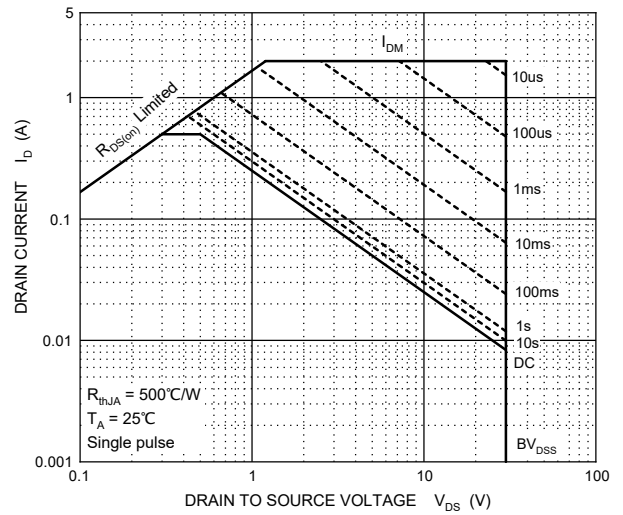

### Transient Thermal Impedance, Junction-Ambient

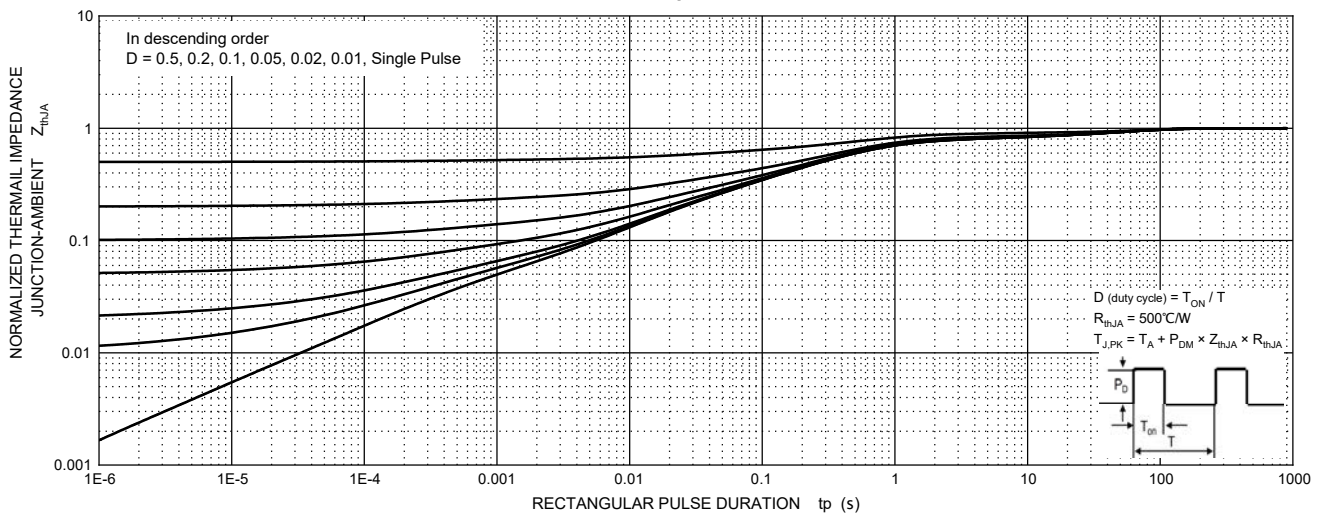

## SOT-523 Package Outline Dimensions

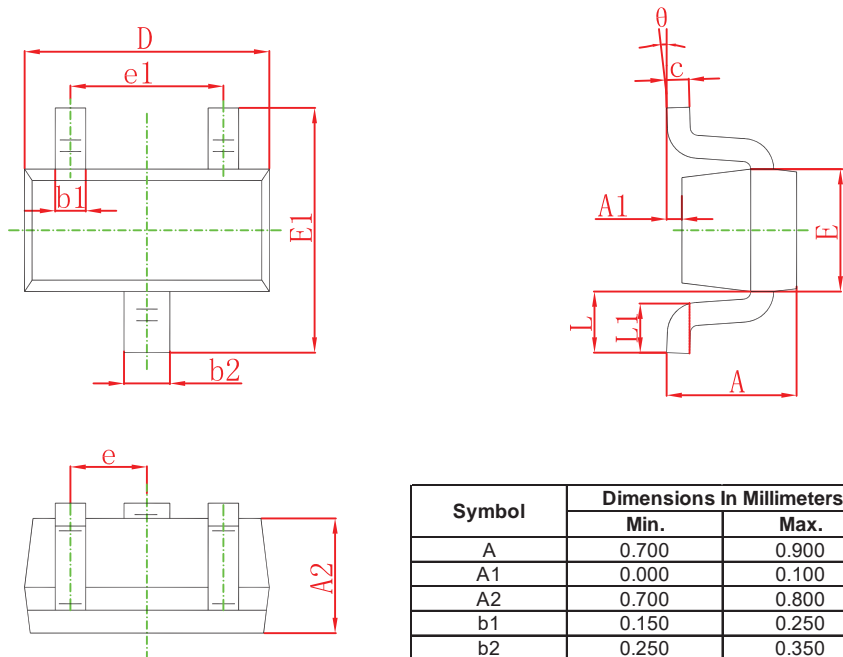

Symbol	Dimensions In Millimeters		Dimensions In Inches	
	Min.	Max.	Min.	Max.
A	0.700	0.900	0.028	0.035
A1	0.000	0.100	0.000	0.004
A2	0.700	0.800	0.028	0.031
b1	0.150	0.250	0.006	0.010
b2	0.250	0.350	0.010	0.014
c	0.100	0.200	0.004	0.008
D	1.500	1.700	0.059	0.067
E	0.700	0.900	0.028	0.035
E1	1.450	1.750	0.057	0.069
e	0.400	0.600	0.160	0.240
e1	0.900	1.100	0.035	0.043
L	0.350	0.450	0.014	0.018
L1	0.260	0.460	0.010	0.018
θ	0°	8°	0°	8°

## SOT-523 Suggested Pad Layout

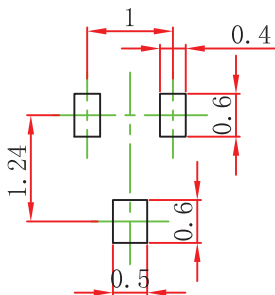

- Note:
1. Controlling dimension: in millimeters.
  2. General tolerance:  $\pm 0.05\text{mm}$ .
  3. The pad layout is for reference purposes only.

### NOTICE

JSCJ reserves the right to make modifications, enhancements, improvements, corrections or other changes without further notice to any product herein. JSCJ does not assume any liability arising out of the application or use of any product described herein.

# SOT-523 Tape and Reel

## SOT-523 Embossed Carrier Tape

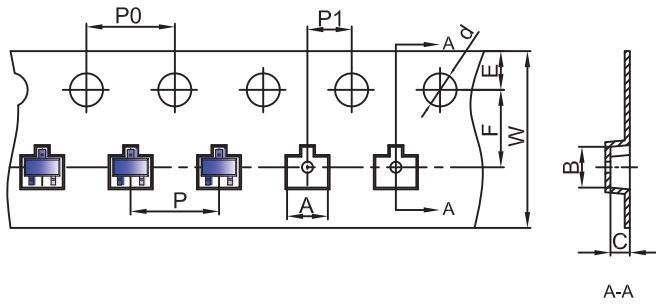

### Packaging Description:

SOT-523 parts are shipped in tape. The carrier tape is made from a dissipative (carbon filled) polycarbonate resin. The cover tape is a multilayer film (Heat Activated Adhesive in nature) primarily composed of polyester film, adhesive layer, sealant, and anti-static sprayed agent. These reeled parts in standard option are shipped with 3,000 units per 7" or 17.8cm diameter reel. The reels are clear in color and is made of polystyrene plastic (anti-static coated).

Dimensions are in millimeter

Pkg type	A	B	C	d	E	F	P0	P	P1	W
SOT-523	1.85	1.85	0.875	Ø1.50	1.75	3.50	4.00	4.00	2.00	8.00

## SOT-523 Tape Leader and Trailer

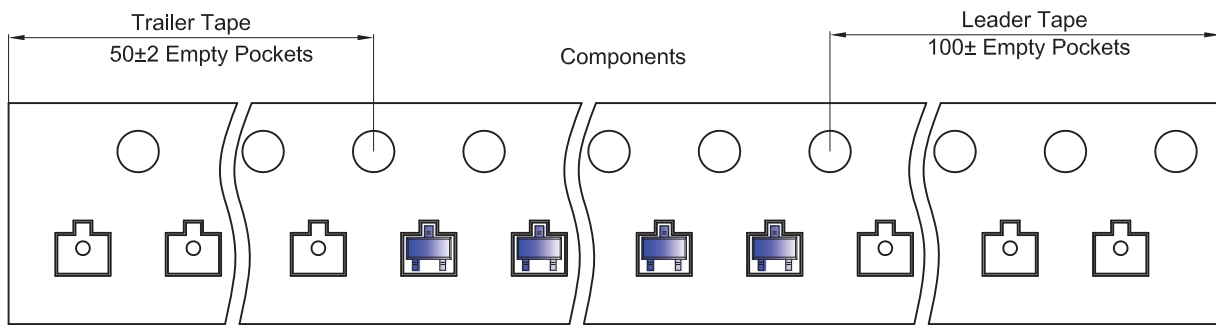

## SOT-523 Reel

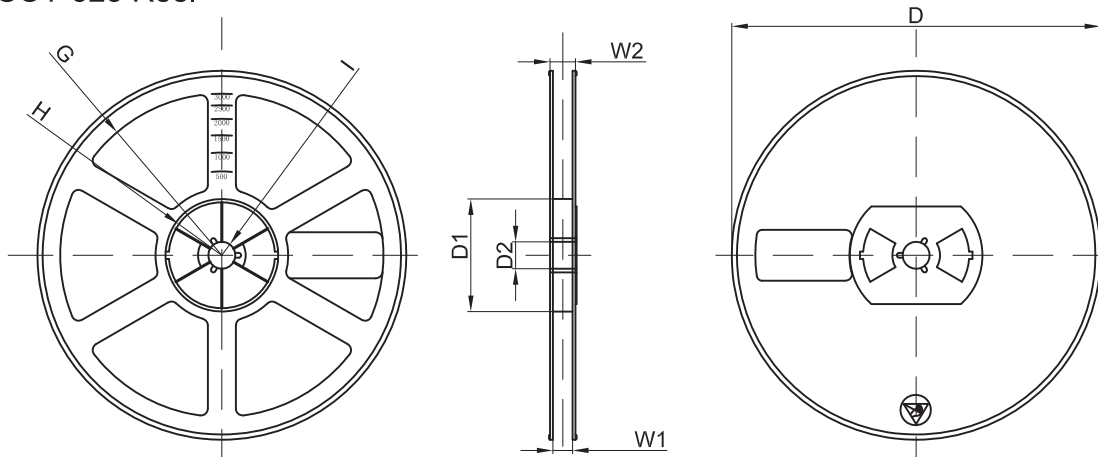

Dimensions are in millimeter

Reel Option	D	D1	D2	G	H	I	W1	W2
7" Dia	Ø178.00	54.40	13.00	R78.00	R25.60	R6.50	9.50	12.30

REEL	Reel Size	Box	Box Size(mm)	Carton	Carton Size(mm)	G.W.(kg)
3000 pcs	7 inch	45,000 pcs	203×203×195	180,000 pcs	438×438×220	