



SOT-23 Plastic-Encapsulate Diodes

BAS19/BAS20 SWITCHING DIODE

FEATURE

- Fast Switching Speed
- Surface Mount Package Ideally Suited for Automatic Insertion
- For General Purpose Switching Applications
- High Conductance

MARKING:

BAS19:JP	BAS20:JR

Soliddot = Green molding compound device.

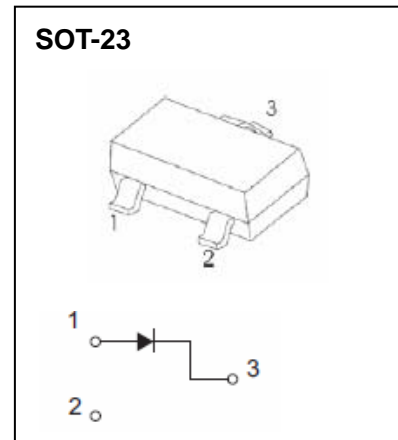

MAXIMUM RATINGS ($T_A=25^{\circ}\text{C}$ unless otherwise noted)

Symbol	Parameter	BAS19	BAS20	Unit
V_{RRM}	Repetitive Peak Reverse Voltage	120	200	V
V_{RWM}	Working Peak Reverse Voltage	100	150	V
I_O	Average Rectified Output Current	200		mA
I_{FSM}	Non-Repetitive Peak Forward Surge Current @ $t=8.3\text{ms}$	2.5		A
P_d	Power Dissipation	250		mW
$R_{\theta JA}$	Thermal Resistance from Junction to Ambient	500		$^{\circ}\text{C/W}$
T_J, T_{stg}	Operation Junction and Storage Temperature Range	-55 ~ +150		$^{\circ}\text{C}$

ELECTRICAL CHARACTERISTICS ($T_A = 25^{\circ}\text{C}$ unless otherwise specified)

Parameter	Symbol	Test Condition	Min	Typ	Max	Unit
Reverse breakdown voltage	BAS19 BAS20	$V_{(BR)}$	$I_R=100\mu\text{A}$	120 200		V
Reverse current	BAS19 BAS20	I_R	$V_R=100\text{V}$ $V_R=150\text{V}$		0.1	μA
Forward voltage	V_F		$I_F=100\text{mA}$		1	V
			$I_F=200\text{mA}$		1.25	V
Diodes capacitance	C_D	$V_R=0\text{V}, f=1\text{MHz}$			5	pF
Reveres recovery time	t_{rr}	$I_F=I_R=30\text{mA}, I_{rr}=0.1 \cdot I_R$			50	ns

Typical Characteristics

Forward Characteristics

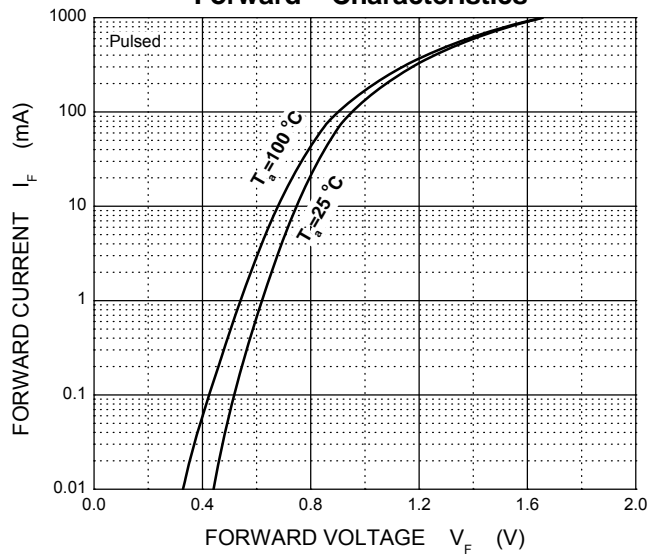

Reverse Characteristics

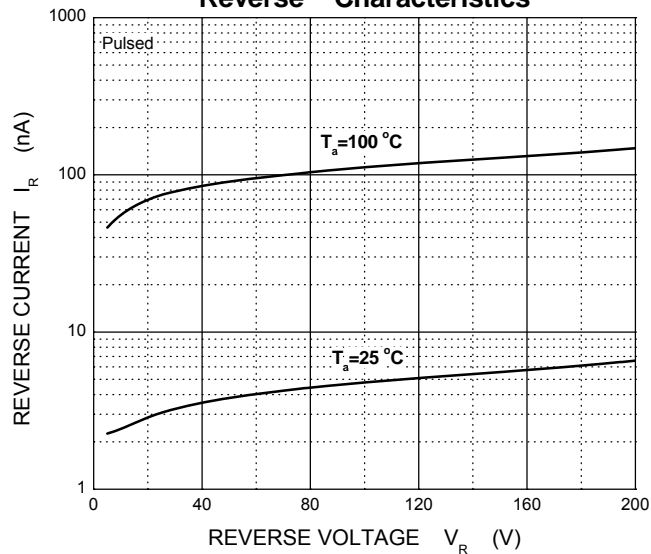

Capacitance Characteristics

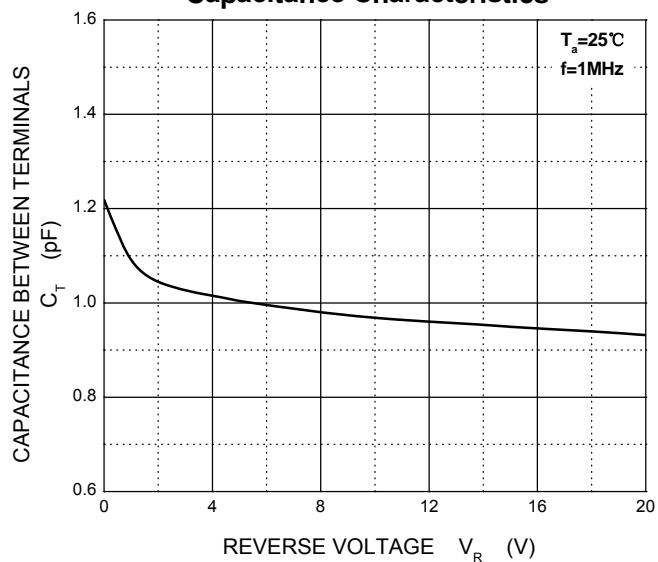

Power Derating Curve

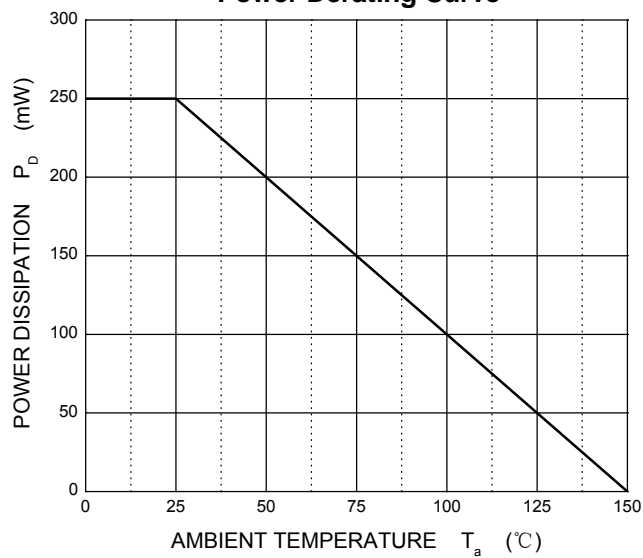

SOT-23 Package Outline Dimensions

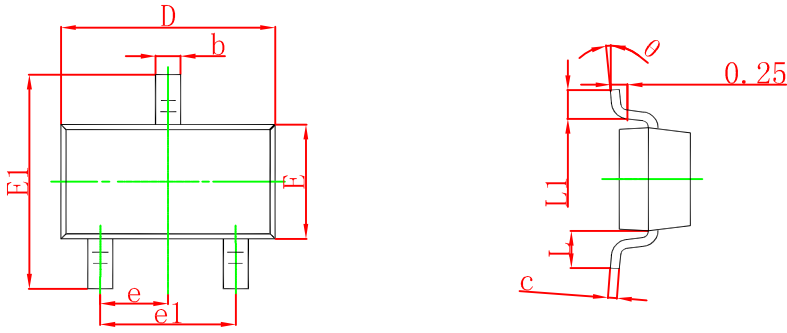

Symbol	Dimensions In Millimeters		Dimensions In Inches	
	Min	Max	Min	Max
A	0.900	1.150	0.035	0.045
A1	0.000	0.100	0.000	0.004
A2	0.900	1.050	0.035	0.041
b	0.300	0.500	0.012	0.020
c	0.080	0.150	0.003	0.006
D	2.800	3.000	0.110	0.118
E	1.200	1.400	0.047	0.055
E1	2.250	2.550	0.089	0.100
e	0.950 TYP		0.037 TYP	
e1	1.800	2.000	0.071	0.079
L	0.550 REF		0.022 REF	
L1	0.300	0.500	0.012	0.020
θ	0°	8°	0°	8°

SOT-23 Suggested Pad Layout



Note:

1. Controlling dimension: in millimeters.
2. General tolerance: $\pm 0.05\text{mm}$.
3. The pad layout is for reference purposes only.

NOTICE

JSCJ reserves the right to make modifications, enhancements, improvements, corrections or other changes without further notice to any product herein. JSCJ does not assume any liability arising out of the application or use of any product described herein.

SOT-23 Tape and Reel

SOT-23 Embossed Carrier Tape

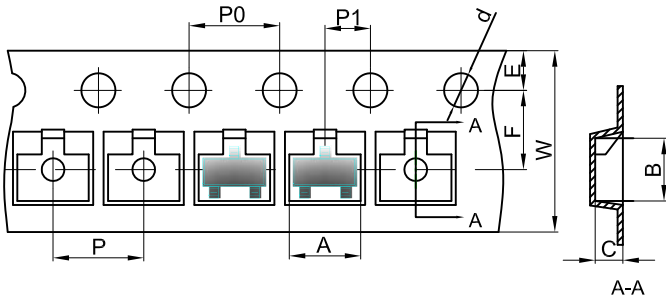

Packaging Description:

SOT-23 parts are shipped in tape. The carrier tape is made from a dissipative (carbon filled) polycarbonate resin. The cover tape is a multilayer film (Heat Activated Adhesive in nature) primarily composed of polyester film, adhesive layer, sealant, and anti-static sprayed agent. These reeled parts in standard option are shipped with 3,000 units per 7" or 17.8cm diameter reel. The reels are clear in color and is made of polystyrene plastic (anti-static coated).

Dimensions are in millimeter

Pkg type	A	B	C	d	E	F	P0	P	P1	W
SOT-23	3.15	2.77	1.22	Ø1.50	1.75	3.50	4.00	4.00	2.00	8.00

SOT-23 Tape Leader and Trailer

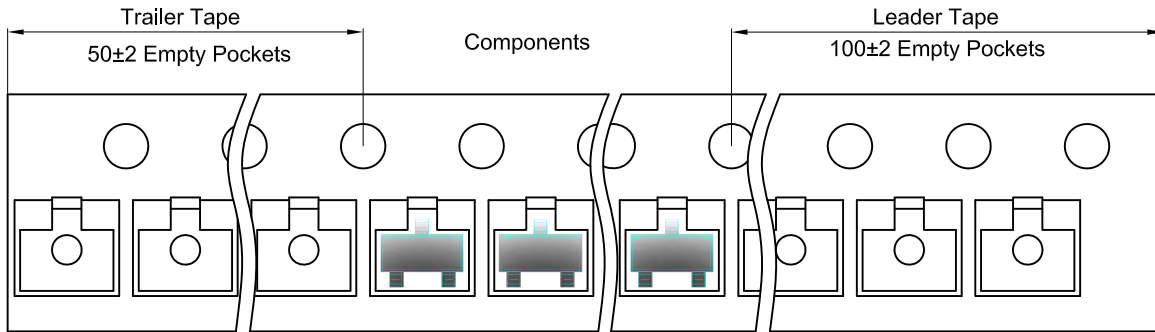

SOT-23 Reel

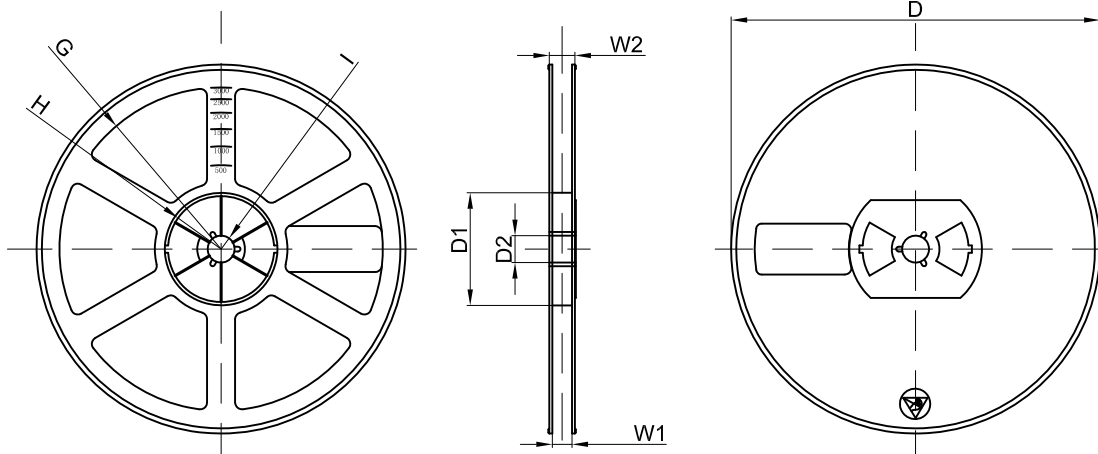

Dimensions are in millimeter

Reel Option	D	D1	D2	G	H	I	W1	W2
7" Dia	Ø178.00	54.40	13.00	R78.00	R25.60	R6.50	9.50	12.30

REEL	Reel Size	Box	Box Size(mm)	Carton	Carton Size(mm)	G.W.(kg)
3000 pcs	7 inch	45,000 pcs	203×203×195	180,000 pcs	438×438×220	