

SOD-723 Plastic-Encapsulate Diodes

BZX784B2V4-BZX784B39 ZENER DIODE

FEATURES

- Planar Die Construction
- 100mW Power Dissipation
- Zener Voltages from 2.4 – 39V

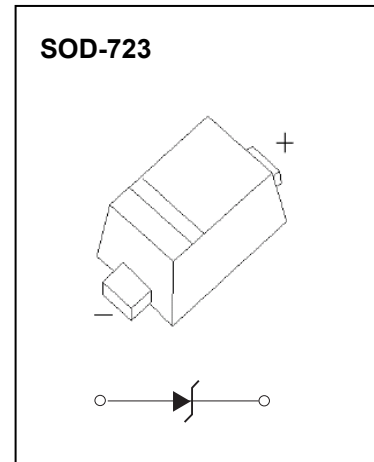

Marking:



XX= Device code, see table on page2 the marking code

The marking bar indicates the cathode

Maximum Ratings @TA=25°C unless otherwise specified

Characteristic	Symbol	Value	Unit
Forward Voltage @I _F =10mA	V _F	0.9	V
Power Dissipation (Note 1)	P _d	100	mW
Thermal Resistance, Junction to Ambient Air	R _{θJA}	1250	°C/W
Operation Junction and Storage Temperature Range	T _J , T _{stg}	-55 ~ +150	

ELECTRICAL CHARACTERISTICS

$T_a=25^{\circ}\text{C}$ unless otherwise specified

Type Number	Type Code	Zener Voltage Range (Note 2)				Maximum Zener Impedance (Note 3)			Maximum Reverse Current		Typical Temperature Coefficient @ $I_{zT}=5\text{ mA}$ mV/ $^{\circ}\text{C}$	
		$V_z@I_{zT}$			I_{zT}	$Z_{zT}@I_{zT}$	$Z_{zK}@I_{zK}$	I_{zK}	I_R	V_R	Min	Max
		Nom(V)	Min(V)	Max(V)	mA	Ω		mA	μA	V		
BZX784B2V4	Z1	2.4	2.35	2.45	5	100	600	1.0	50	1.0	-3.5	0
BZX784B2V7	Z2	2.7	2.65	2.75	5	100	600	1.0	20	1.0	-3.5	0
BZX784B3V0	Z3	3	2.94	3.06	5	95	600	1.0	10	1.0	-3.5	0
BZX784B3V3	Z4	3.3	3.23	3.37	5	95	600	1.0	5	1.0	-3.5	0
BZX784B3V6	Z5	3.6	3.53	3.67	5	90	600	1.0	5	1.0	-3.5	0
BZX784B3V9	Z6	3.9	3.82	3.98	5	90	600	1.0	3	1.0	-3.5	0
BZX784B4V3	Z7	4.3	4.21	4.39	5	90	600	1.0	3	1.0	-3.5	0
BZX784B4V7	X1	4.7	4.61	4.79	5	80	500	1.0	3	2.0	-3.5	0.2
BZX784B5V1	X2	5.1	5.00	5.20	5	60	480	1.0	2	2.0	-2.7	1.2
BZX784B5V6	X3	5.6	5.49	5.71	5	40	400	1.0	1	2.0	-2.0	2.5
BZX784B6V2	X4	6.2	6.08	6.32	5	10	150	1.0	3	4.0	0.4	3.7
BZX784B6V8	X5	6.8	6.66	6.94	5	15	80	1.0	2	4.0	1.2	4.5
BZX784B7V5	X6	7.5	7.35	7.65	5	15	80	1.0	1	5.0	2.5	5.3
BZX784B8V2	X7	8.2	8.04	8.36	5	15	80	1.0	0.7	5.0	3.2	6.2
BZX784B9V1	X8	9.1	8.92	9.28	5	15	100	1.0	0.5	6.0	3.8	7.0
BZX784B10	X9	10	9.80	10.20	5	20	150	1.0	0.2	7.0	4.5	8.0
BZX784B11	W1	11	10.78	11.22	5	20	150	1.0	0.1	8.0	5.4	9.0
BZX784B12	W2	12	11.76	12.24	5	25	150	1.0	0.1	8.0	6.0	10.0
BZX784B13	W3	13	12.74	13.26	5	30	170	1.0	0.1	8.0	7.0	11.0
BZX784B15	W4	15	14.70	15.30	5	30	200	1.0	0.1	10.5	9.2	13.0
BZX784B16	W5	16	15.68	16.32	5	40	200	1.0	0.1	11.2	10.4	14.0
BZX784B18	W6	18	17.64	18.36	5	45	225	1.0	0.1	12.6	12.4	16.0
BZX784B20	W7	20	19.60	20.40	5	55	225	1.0	0.1	14.0	14.4	18.0
BZX784B22	W8	22	21.56	22.44	5	55	250	1.0	0.1	15.4	16.4	20.0
BZX784B24	W9	24	23.52	24.48	5	70	250	1.0	0.1	16.8	18.4	22.0
BZX784B27	Y1	27	26.46	27.54	2	80	300	0.5	0.1	18.9	21.4	25.3
BZX784B30	Y2	30	29.40	30.60	2	80	300	0.5	0.1	21.0	24.4	29.4
BZX784B33	Y3	33	32.34	33.66	2	80	325	0.5	0.1	23.1	27.4	33.4
BZX784B36	Y4	36	35.28	36.72	2	90	350	0.5	0.1	25.2	30.4	37.4
BZX784B39	Y5	39	38.22	39.78	2	130	350	0.5	0.1	27.3	33.4	41.2

Notes:

1. Valid provided that device terminals are kept at ambient temperature.
2. Tested with pulses, period=5ms,pulse width =300us.
3. $f = 1\text{ KHz}$

Typical Characteristics

Notes: Our company currently provide 5.1 V - 20 V products only

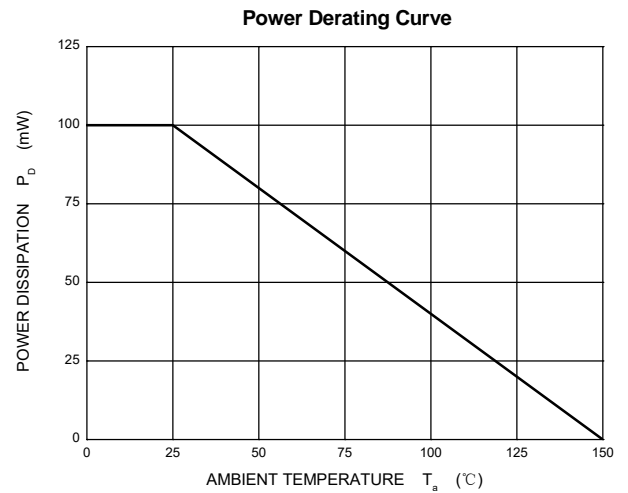
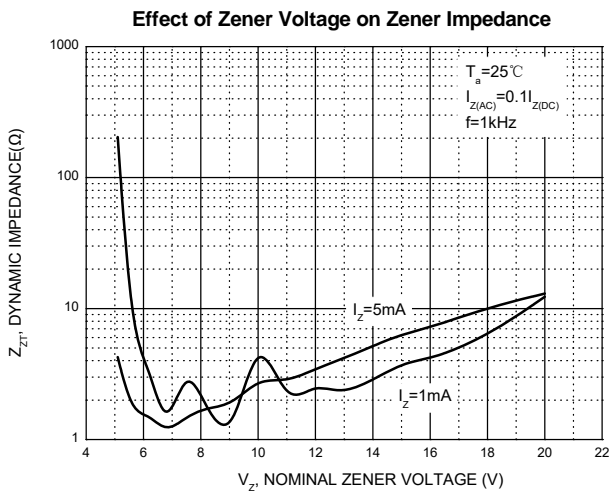
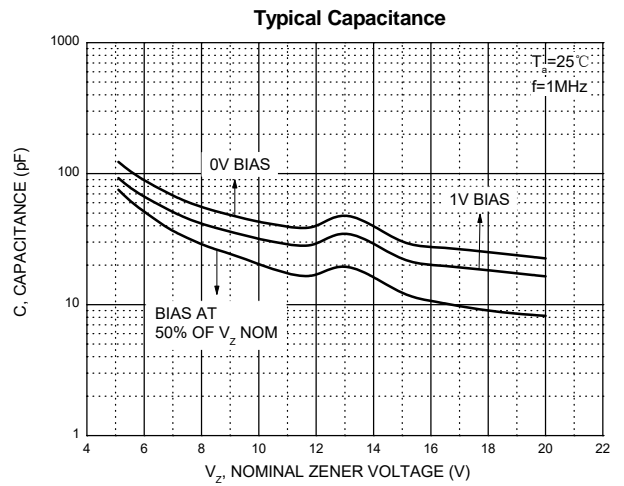
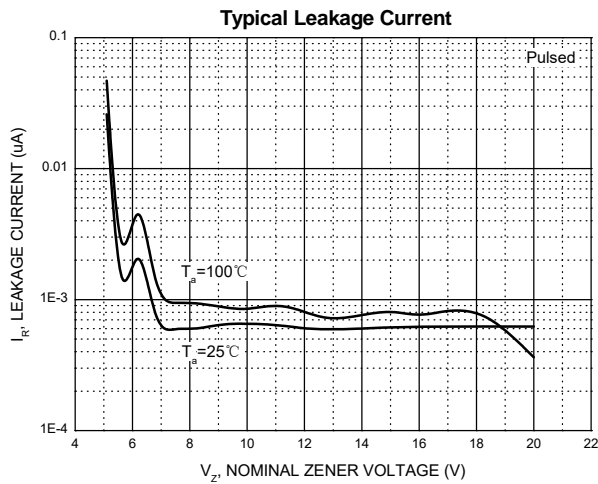
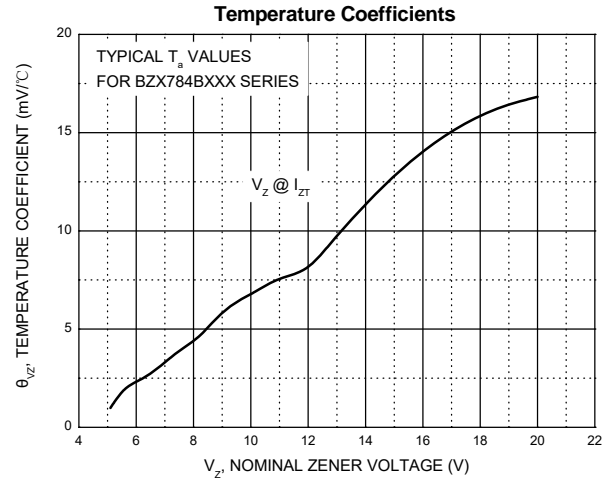
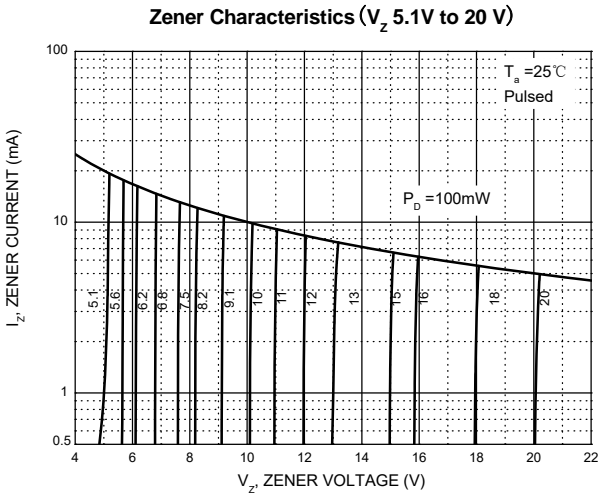

SOD-723 Package Outline Dimensions

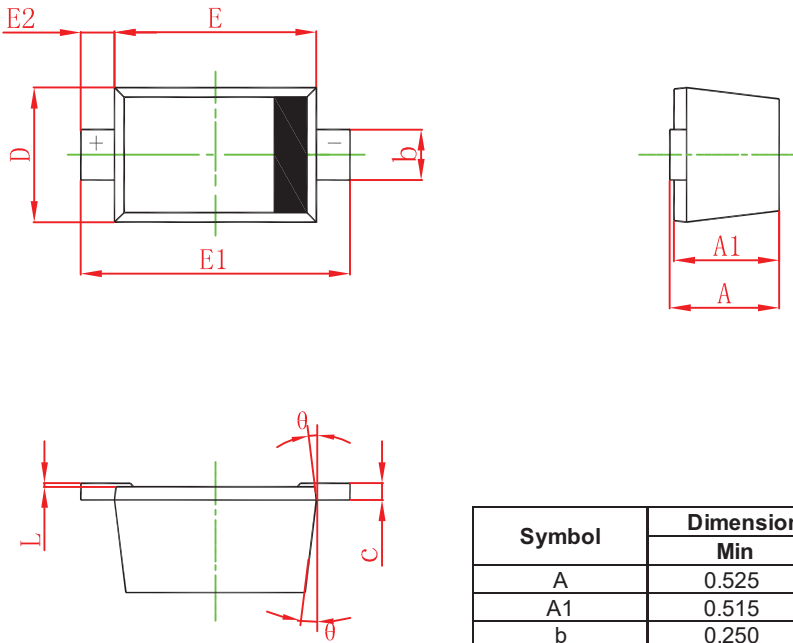

Symbol	Dimensions In Millimeters		Dimensions In Inches	
	Min	Max	Min	Max
A	0.525	0.650	0.021	0.026
A1	0.515	0.580	0.020	0.023
b	0.250	0.350	0.010	0.014
c	0.080	0.150	0.003	0.006
D	0.550	0.650	0.022	0.026
E	0.900	1.100	0.035	0.043
E1	1.300	1.500	0.051	0.059
E2	0.200 REF		0.008 REF	
L	0.010	0.070	0.001	0.003
θ	7° REF		7° REF	

SOD-723 Suggested Pad Layout

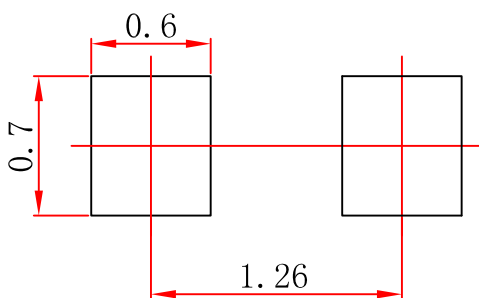

Note:

1. Controlling dimension: in millimeters.
2. General tolerance: ± 0.05 mm.
3. The pad layout is for reference purposes only.

NOTICE

JSCJ reserves the right to make modifications, enhancements, improvements, corrections or other changes without further notice to any product herein. JSCJ does not assume any liability arising out of the application or use of any product described herein.

SOT-723 Tape and Reel

SOT-723 Embossed Carrier Tape

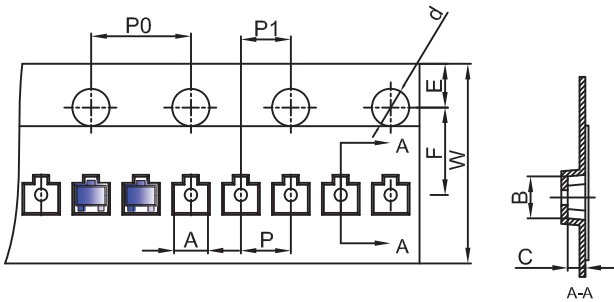

Packaging Description:

SOT-723 parts are shipped in tape. The carrier tape is made from a dissipative (carbon filled) polycarbonate resin. The cover tape is a multilayer film (Heat Activated Adhesive in nature) primarily composed of polyester film, adhesive layer, sealant, and anti-static sprayed agent. These reeled parts in standard option are shipped with 8,000 units per 7" or 17.8cm diameter reel. The reels are clear in color and is made of polystyrene plastic (anti-static coated).

Dimensions are in millimeter										
Pkg type	A	B	C	d	E	F	P0	P	P1	W
SOT-723	1.33	1.45	0.61	Ø1.50	1.75	3.50	4.00	2.00	2.00	8.00
(Tolerance)	+/-0.05	+/-0.05	+/-0.05	+/-0.1	+/-0.1	+/-0.1	+/-0.1	+/-0.1	+/-0.1	+0.3/-0.1

SOT-723 Tape Leader and Trailer

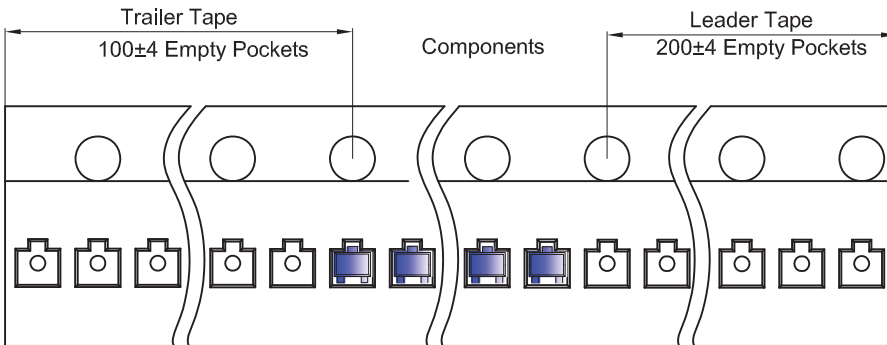

SOT-723 Reel

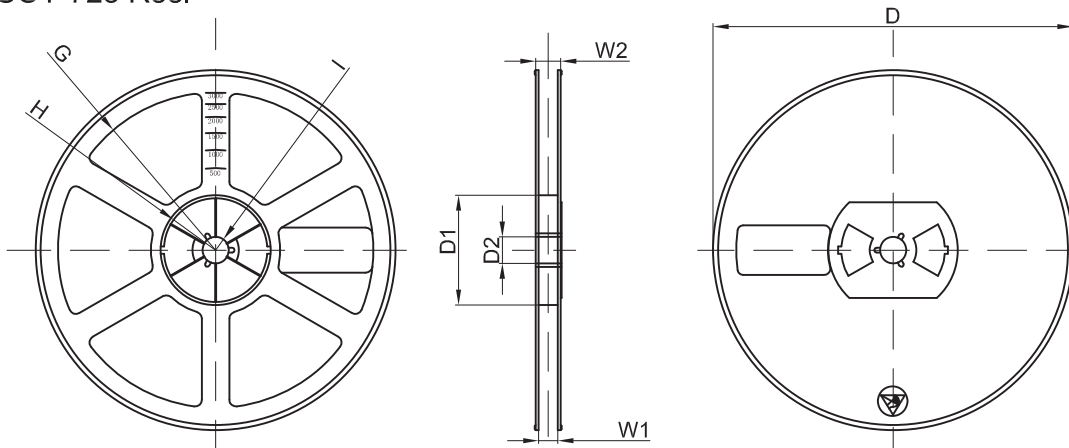

Dimensions are in millimeter								
Reel Option	D	D1	D2	G	H	I	W1	W2
7" Dia	Ø178.00	54.40	13.00	R78.00	R25.60	R6.50	9.50	12.30
Tolerance	+/-2	+/-1	+/-1	+/-1	+/-1	+/-1	+/-1	+/-1

REEL	Reel Size	Box	Box Size(mm)	Carton	Carton Size(mm)	G.W.(kg)
8,000 pcs	7 inch	120,000 pcs	210×208×205	480,000 pcs	440×440×230	