



CJ40562 Series

■ INTRODUCTION:

The CJ40562 is a complete constant-current/constant-voltage linear charger for single cell lithium rechargeable battery. No external sense resistor is needed, and no blocking diode is required due to the internal P-MOSFET architecture. Furthermore, the CJ40562 is specifically designed to work within USB power specifications. Its low external component count makes the CJ40562 ideally suited for portable applications. Thermal feedback regulates the charge current to limit the die temperature during high power operation or high ambient temperature. The charge current can be programmed externally with a single resistor. The CJ40562 automatically terminates the charge cycle when the charge current drops to 1/10th the programmed value after the final float voltage is reached. When the input supply (wall adapter or USB supply) is removed, the CJ40562 automatically enters a low power sleep mode, dropping the battery drain current to less than 2 μ A. The CJ40562 can be put into shutdown mode, supply current to 50 μ A. Other features include battery pack temperature monitor, undervoltage lockout, automatic recharge and two status pins to indicate charging and charge termination.

■ APPLICATIONS:

- Cellular phones, PDAs
- Portable Media Players
- Digital Still Cameras
- Bluetooth & GPS Applications
- Mobile Internet Device
- Charging Docks and Cradles

■ FEATURES:

- Charges Single Cell Lithium Battery Directly from USB Port or AC Adapter
- Input Voltage Range From 4.5V to 6.5V
- No External MOSFET, Sense Resistor or Blocking Diode Required
- Preset 4.20V/4.35V Charge Voltage
- Continuous Programmable Charge Current Up to 1A
- Precharge Conditioning for Reviving Deeply Discharged Cells and Minimizing Heat Dissipation During Initial Stage of Charge
- Constant-Current/Constant-Voltage/Constant-Temp Operation with Thermal Regulation to Maximize Charge Rate Without Risk of Overheating
- Charge Termination: C/10
- Automatic Recharge
- Battery Temperature Sensing
- Charge state pairs of output, no battery and fault status display
- Charge Current Monitor Output for Gas Gauging
- Automatic Low Power Sleep Mode When Input Supply Voltage is Removed
- Soft-Start Limits Inrush Current
- Chip Enable Input

■ DEVICE INFORMATION:

PART NUMBER	Vfloat	PACKAGE
CJ40562A420ES	4.2V	SOP8-PP
CJ40562A435ES	4.35V	SOP8-PP
CJ40562A420FB8	4.2V	DFNWB2 \times 2-8L

BLOCK DIAGRAM

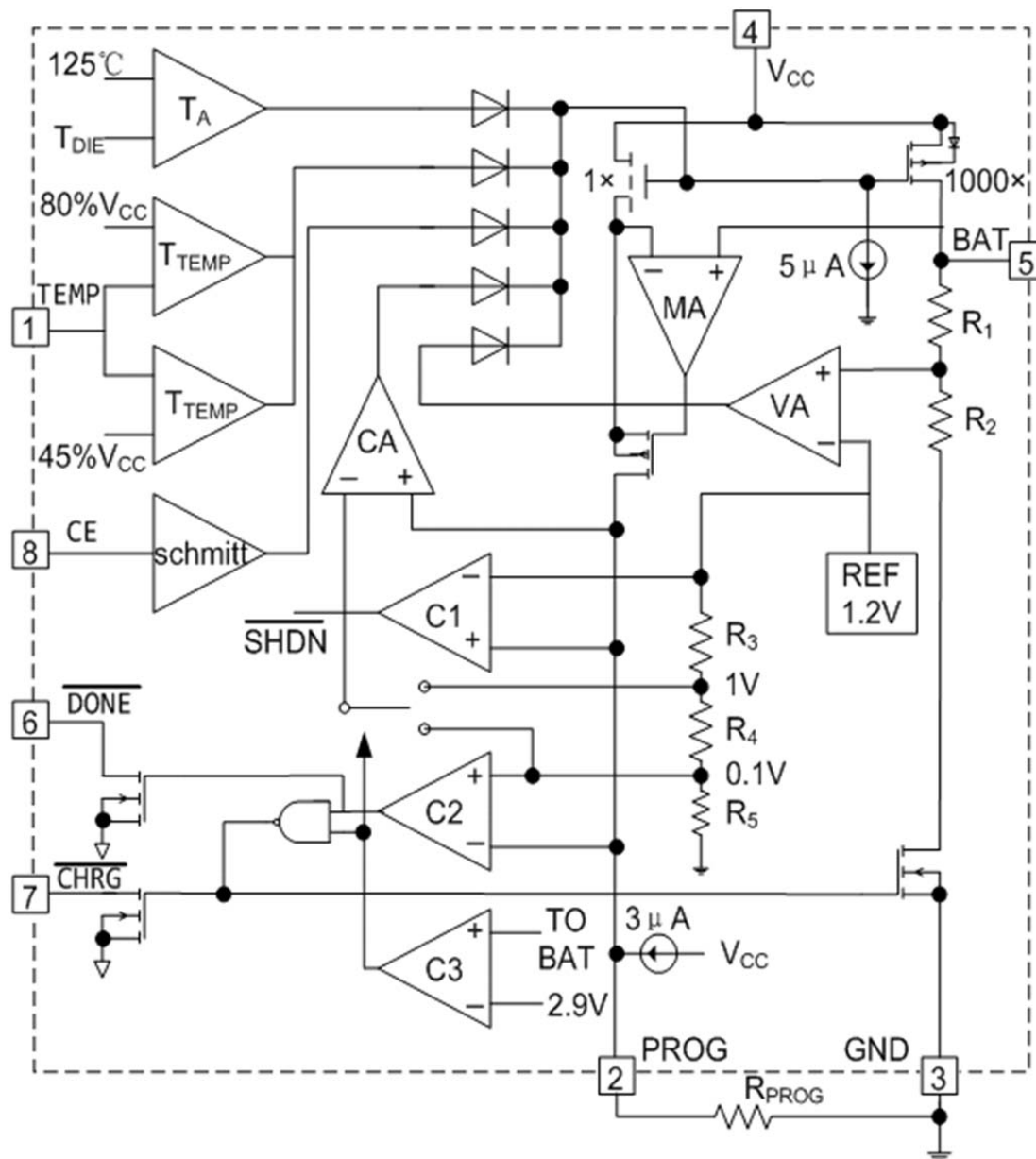

Future 1 Functional Block Diagram

■ PIN CONFIGURATION

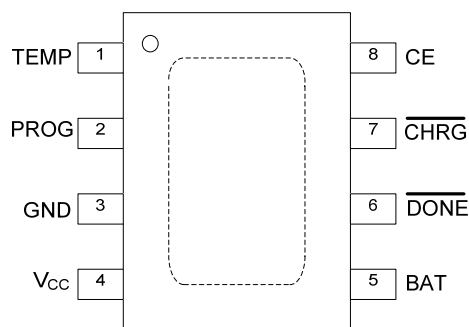

SOP8-PP(Top View)

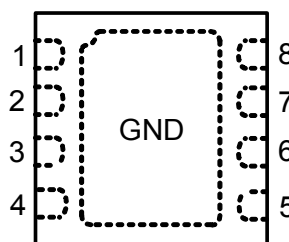

DFNWB2x2-8L(Top View)

Table 1. Pin Description

PIN NO.	PIN NAME	FUNCTION
1	TEMP	Battery temperature detection input. Connecting TEMP pin to NTC thermistor's sensor output in Lithium ion battery pack. If the TEMP pin's voltage is less than 45% or greater than 80% of the input voltage V_{CC} , this means the battery temperature is too high or too low, charging is suspended. If the TEMP pin's voltage level is between 45% and 80% of the input voltage V_{CC} , battery fault state is released, and charging will resume. If the TEMP pin direct access GND, battery temperature detection canceled, the other charged functioning properly.
2	PROG	Constant Charge Current Setting and Charge Current Monitor Pin. The charge current is set by connecting a 1% accuracy metal film resistor R_{PROG} from this pin to GND. When charging in precharge mode, the PROG pin voltage is regulated to 0.1V. When charging in constant-current mode, the PROG pin voltage is regulated to 1V. In all modes during charging, the voltage on PROG pin can be used to measure the charge current as the following formula: $I_{BAT} = (V_{PROG} / R_{PROG}) \times 1000$
3	GND	Ground Terminal.
4	V_{CC}	Positive Input Supply Voltage. V_{CC} is the power supply to the internal circuit. V_{CC} can range from 4.5V to 6.5V and should be bypassed with at least a 4.7 μ F capacitor. When V_{CC} drops to within 80mv of the BAT pin voltage, CJ40562 enters low power sleep mode, dropping BAT pin's current to less than 2 μ A.
5	BAT	Charger Power Stage Current Output and Battery Voltage Sense Input. BAT pin provides charge current to the battery and regulates the final float voltage. An internal precision resistor divider from this pin sets the float voltage which is disconnected in shutdown mode. Connect the positive terminal of the battery to BAT pin. Bypass BAT to GND with 10 μ F to 47 μ F capacitor. BAT pin draws less than 2 μ A current in chip disable mode or in sleep mode.
6	\overline{DONE}	Open-Drain Charge termination Status Output. In charge termination status, \overline{DONE} is pulled low by an internal switch; Otherwise \overline{DONE} pin is in high impedance state.
7	\overline{CHRG}	Open Drain Charge Status Output. When the battery is being charged, the \overline{CHRG} pin is pulled low by an internal switch, otherwise \overline{CHRG} pin is in high impedance state.
8	CE	Chip Enable Input. A high input will put the device in the normal operating mode. Pulling the CE pin to low level will put the CJ40562 into disable mode. The CE pin can be driven by TTL or CMOS logic level. The CE pin is high impedance with internal 1.1M Pull-up Resistor in the suspended state.
EP	Thermal PAD	Exposed Paddle (bottom). This pin should be soldered to the PCB ground as close as to the device for electrical contact and rated thermal performance.

Electrical Characteristics

■ ABSOLUTE MAXIMUM RATINGS⁽¹⁾

(unless otherwise specified , $T_A=25^{\circ}\text{C}$)

PARAMETER	SYMBOL	RATINGS	UNITS	
Input Supply Voltage ⁽²⁾	V_{CC}	-0.3~10	V	
TEMP, CE, PROG Pins Voltage ⁽²⁾		-0.3~ $V_{CC}+0.3$		
BAT Pin Voltage ⁽²⁾		-0.3~8		
$\overline{\text{CHRG}}$, $\overline{\text{DONE}}$ Pins Voltage ⁽²⁾		-0.3~10		
BAT Short-Circuit Duration	-	Continuous	-	
BAT Pin Output Current (Continuous)	I_{BAT}	1200	mA	
Output sink current	$I_{\overline{\text{CHRG}}}$, $I_{\overline{\text{DONE}}}$	10	mA	
Power dissipation	P_D	SOP8-PP	1200	mW
		DFNWB2×2-8L	1000	mW
Operating Ambient Temperature Range ⁽³⁾	T_A	-40~85	$^{\circ}\text{C}$	
Junction Temperature	T_J	-40~150	$^{\circ}\text{C}$	
Storage Temperature	T_{stg}	-40~125	$^{\circ}\text{C}$	
Lead Temperature (Soldering, 10s)	T_{solder}	260	$^{\circ}\text{C}$	
ESD rating ⁽⁴⁾	HBM JESD22-A114A	4000	V	
	MM JESD22-A115A	200	V	

(1) Stresses beyond those listed under *absolute maximum ratings* may cause permanent damage to the device. These are stress ratings only, and functional operation of the device at these or any other conditions beyond those indicated under *recommended operating conditions* is not implied. Exposure to absolute-maximum-rated conditions for extended periods may affect device reliability.

(2) All voltages are with respect to network ground terminal.

(3) The CJ40562 are guaranteed to meet performance specifications from 0°C to 70°C . Specifications over the -40°C to 85°C operating temperature range are assured by design, characterization and correlation with statistical process controls.

(4) ESD testing is performed according to the respective JESD22 JEDEC standard.

The human body model is a 100 pF capacitor discharged through a 1.5k Ω resistor into each pin. The machine model is a 200pF capacitor discharged directly into each pin.

■ RECOMMENDED OPERATING CONDITIONS

PARAMETER	SYMBOL	MIN	MAX	UNITS
Input voltage range ⁽⁵⁾	V_{CC}	4.5	6.5	V
BAT Pin Output Current (Continuous)	I_{BAT}		1000 ⁽⁶⁾	mA
Operating junction temperature range	T_J	0	70	$^{\circ}\text{C}$
Fast-charge current programming resistor ⁽⁷⁾	R_{PROG}	1	10	k Ω

(5) If V_{CC} is between UVLO and 4.5V, and above the battery voltage, then the IC is active (can deliver some charge to the battery), but the IC will have limited or degraded performance (some functions may not meet data sheet specifications). The battery may be undercharged (V_{FLOAT} less than in the specification), but will not be overcharged (V_{FLOAT} will not exceed specification).

(6) The thermal regulation feature reduces charge current if the IC's junction temperature reaches 125°C ; thus without a good thermal design the maximum programmed charge current may not be reached.

(7) Use a 1% tolerance metal film resistor for R_{PROG} to avoid issues with the R_{PROG} short test when using the maximum charge current setting.

Electrical Characteristics

($V_{CC}=5V$, $T_A=25^{\circ}C$, Test Circuit Figure2, unless otherwise specified)

PARAMETER	SYMBOL	CONDITIONS	MIN	TYP	MAX	UNITS
V_{CC} Under voltage Lockout Threshold	V_{UVL}	V_{CC} from Low to High		3.9		V
V_{CC} Under voltage Lockout Hysteresis	ΔV_{UVL}			150		mV
Input Supply Current	I_{CC}	Charge Mode, $R_{PROG}=10K$		150	500	μA
		Standby Mode (Charge Terminated)		50	100	
		Shutdown Mode: R_{PROG} Not Connected, $V_{CC}<V_{BAT}$, or $V_{CC}<V_{UVL}$		50	100	
CE "High" Level Voltage	V_{CEH}		1.5		V_{CC}	V
CE "Low" Level Voltage	V_{CEL}				0.4	V
Trickle Charge Threshold	V_{TRIKL}	$R_{PROG}=10K$, V_{BAT} Rising		2.9		V
Trickle Charge Hysteresis	ΔV_{TRIKL}	$R_{PROG}=10K$		100		mV
Trickle Charge Current	I_{TRIKL}	$R_{PROG}=1K$, For SCJ4056A	90	100	110	mA
		$R_{PROG}=1K$, For SCJ4056B	225	250	275	mA
BAT Pin Current	I_{BAT}	$R_{PROG}=1K$, Current Mode($V_{BAT}=4.0V$)	900	1000	1100	mA
		$R_{PROG}=2K$, Current Mode($V_{BAT}=4.0V$)	450	500	550	
		Standby Mode, $V_{BAT}=V_{FLOAT}$	0	-2.5	-6.0	μA
		Shutdown Mode (R_{PROG} Not Connected)		± 1	± 2	
		Sleep Mode, $V_{CC}=0V$		-1	-2	
PROG Pin Voltage	V_{PROG}	$R_{PROG}=1K$, Current Mode	0.9	1.0	1.1	V
PROG Pin Pull-Up Current	I_{PROG}			3		μA
Regulated Output (Float) Voltage	V_{FLOAT}	$0^{\circ}C \leq T_A \leq 85^{\circ}C$, $I_{BAT}=20mA$, $R_{PROG}=10K$	4.158	4.200	4.250	V
			4.300	4.350	4.400	V
C/10 Termination Current Threshold	I_{TERM}	$R_{PROG}=1K$, For SCJ4056A		0.1		mA/mA
		$R_{PROG}=1K$, For SCJ4056B		0.25		mA/mA
Termination Comparator Filter Time	t_{TERM}	I_{BAT} Falling Below I_{TERM}	0.8	1.8	4.0	mS
Recharge Battery Threshold	ΔV_{RECHG}	$V_{FLOAT}-V_{RECHG}$		150		mV
Recharge Comparator Filter Time	$t_{RECHARGE}$	V_{BAT} High to Low	0.8	1.8	4.0	mS

Electrical Characteristics (continued)

($V_{CC}=5V$, $T_A=25^{\circ}C$, Test Circuit Figure2, unless otherwise specified)

$V_{CC} - V_{BAT}$ Lockout Threshold	A_{MSD}	V_{CC} from Low to High		100		mV
		V_{CC} from High to Low		80		mV
\overline{CHRG} Pin Voltage	$V_{\overline{CHRG}}$	$I_{\overline{CHRG}}=5mA$		0.3	0.6	V
\overline{DONE} Pin Voltage	$V_{\overline{DONE}}$	$I_{\overline{DONE}}=5mA$		0.3	0.6	V
TEMP High Shift Voltage Level				80	82	% V_{CC}
TEMP Low Shift Voltage Level			43	45		
Soft-Start Time	t_{SS}	$I_{BAT}=0$ to $I_{BAT}=1000V/R_{PROG}$		20		μS
Power FET "ON" Resistance (Between V_{CC} and BAT)	R_{ON}	$I_{BAT}=1000mA$		400		$m\Omega$
Junction Temperature in Constant Temperature Mode	$T_{J(REG)}$			125		$^{\circ}C$

■ TYPICAL APPLICATION CIRCUIT

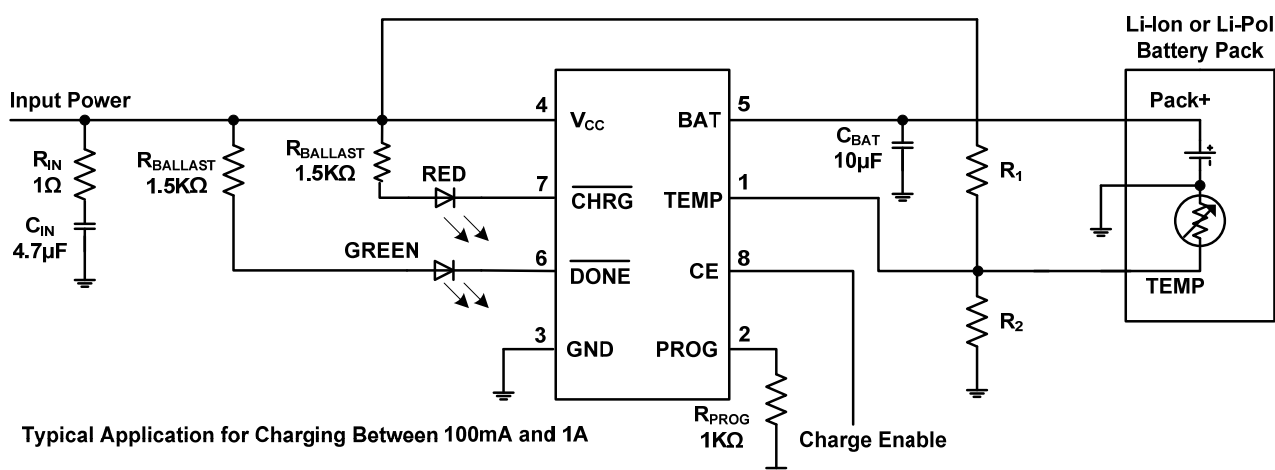

Figure 2 Standard Application Circuit

Typical Characteristics

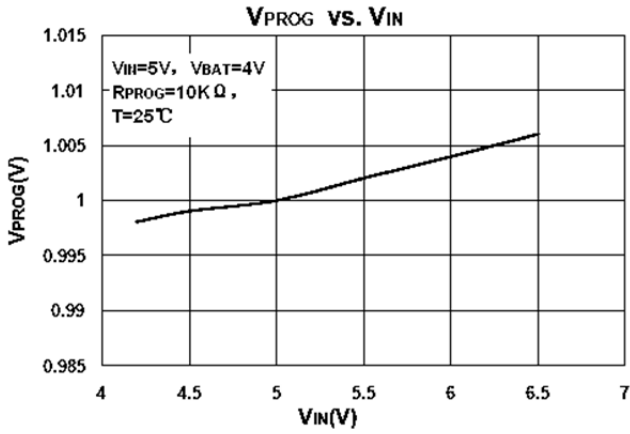

Figure 3

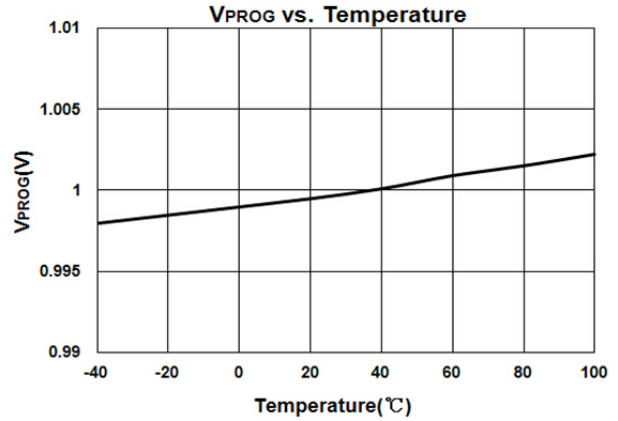

Figure 4

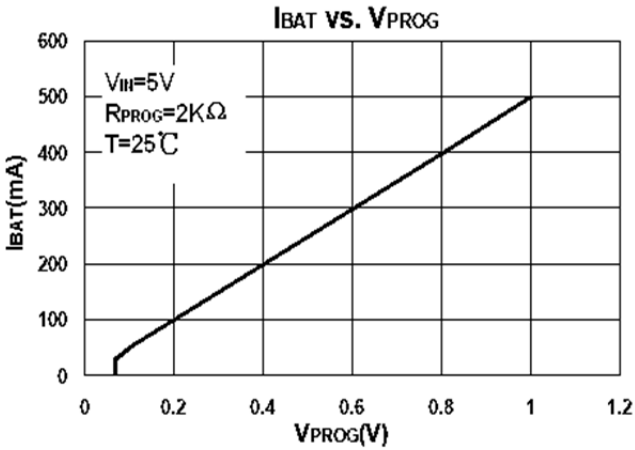

Figure 5

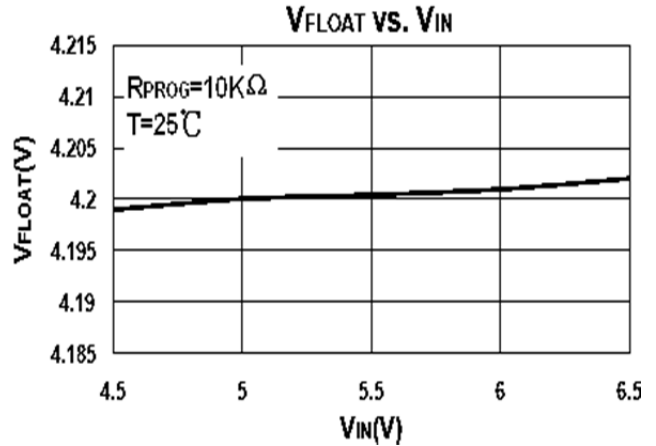

Figure 6

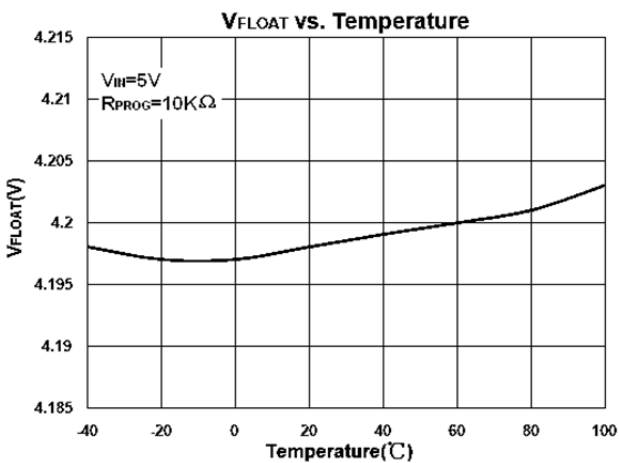

Figure 7

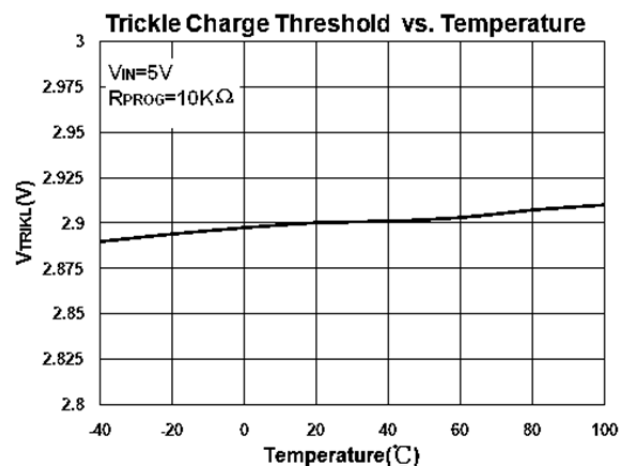

Figure 8

Typical Characteristics (continued)

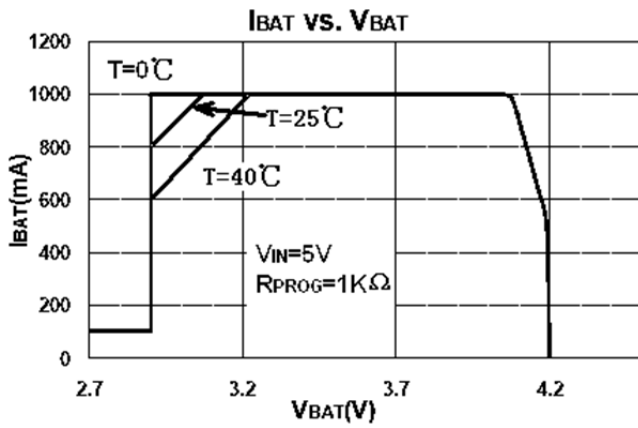

Figure 9

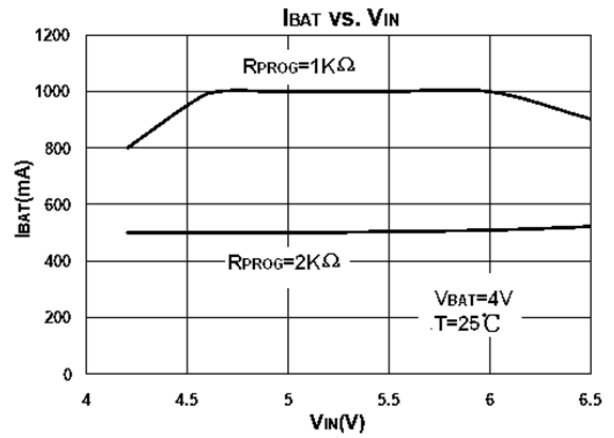

Figure 10

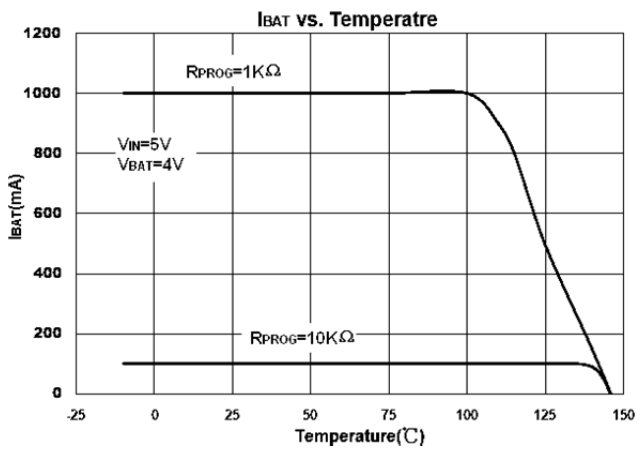

Figure 11

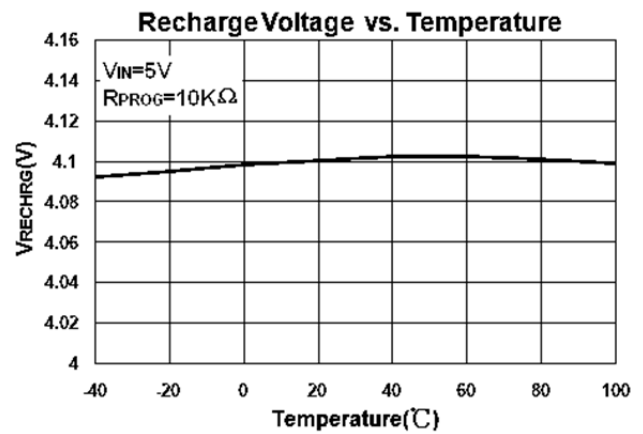

Figure 12

■ FUNCTIONAL DESCRIPTION

The CJ40562 series are highly integrated Li-Ion or Li-Pol linear battery chargers, targeted at space-limited portable applications. It operates from either a USB port or Wall Adapter and charges a single-cell Li-Ion or Li-Pol battery with up to 1200mA of charge current.

The charge current is programmable using external components (R_{PROG} resistor). The charge process starts when an external input power is connected to the system, $V_{CC} > V_{UVL}$, $V_{CC} > V_{BAT} + V_{(SLP_EXIT)}$, the charger is enabled by the R_{PROG} resistor connected and the battery voltage is below the recharge threshold, $V_{BAT} < V_{RECHG}$.

When the charger is enabled two control loops modulate the battery switch drain to source impedance to limit the BAT pin current to the programmed charge current value (charge current loop) or to regulate the BAT pin voltage to the programmed charge voltage value (charge voltage loop). If $V_{BAT} < V_{TRIKL}$ (2.9 V typical), the BAT pin current is internally set to 1/10th of the programmed fast-charge current value in current regulation mode.

The CJ40562 series provide battery charge status via \overline{CHRG} & \overline{DONE} status pins. \overline{CHRG} & \overline{DONE} pins are internally connected to an N-channel open drain MOSFET.

The open drain status output that is not used should be tied to ground.

The following table lists the indicator status and its corresponding charging state.

Table 1. Charge Status Indicator⁽¹⁾

Charge State Description	\overline{CHRG}	\overline{DONE}
Preconditioning-Current Mode (Trickle) Charge	ON	HI-Z
Constant-Current Mode (Fast) Charge	ON	HI
Constant-Voltage Mode (Taper) Charge, $I_{BAT} > I_{TERM}$	ON	HI-Z
Charge Termination ($I_{BAT} < I_{TERM}$, Charge Done)	HI-Z	ON
Power Down(Under voltage Lockout) Mode	HI-Z	HI-Z
Sleep Mode ($V_{UVL} < V_{CC} < V_{BAT} + V_{(SLP_EXIT)}$, or the V_{CC} is removed)	HI-Z	
Shutdown Mode(PROG pin floating)	HI-Z	HI-Z
OVP Mode ($V_{CC} > V_{OVP}$)	HI-Z	HI-Z
No battery with Charge Enabled	FLASH Rate depends on C_{BAT}	FLASH
Fault Condition (Battery Short Circuit)	ON	HI-Z
Fault TEMP($5\% V_{CC} < V_{TEMP} < 45\% V_{CC}$ $V_{TEMP} > 80\% V_{CC}$)	HI-Z	HI-Z

(1)Pulse loading on the BAT pin may cause the IC to cycle between done and charging states (LEDs Flashing)

DFNWB2×2-8L Package Outline Dimensions

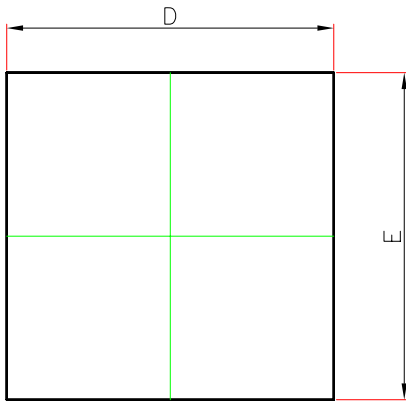

TOP VIEW

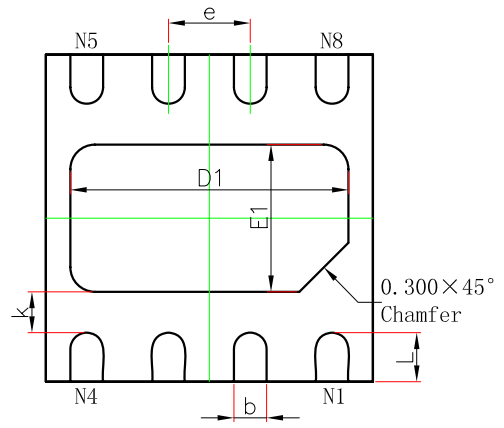

BOTTOM VIEW

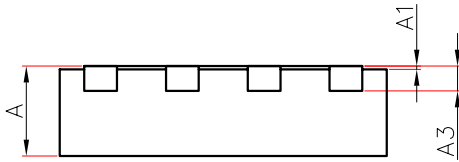

SIDE VIEW

SYMBOL	Dimensions In Millimeters		
	MIN	NOM	MAX
A	0.50	0.55	0.60
A1	0.00	-	0.05
A3	0.152REF		
b	0.15	0.20	0.25
D	1.90	2.00	2.10
E	1.90	2.00	2.10
D1	1.60	1.70	1.80
E1	0.80	0.90	1.00
e	0.40	0.50	0.60
K	0.50TYP		
L	0.25	0.30	0.35

SOP8-PP Package Outline Dimensions

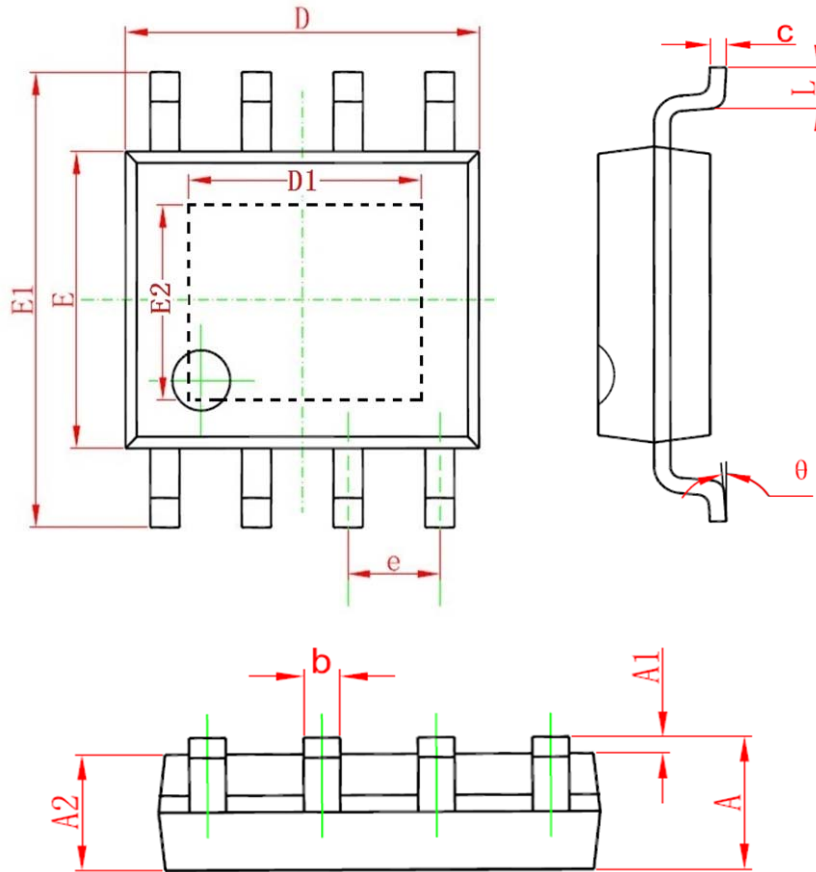

Symbol	Dimensions In Millimeters		Dimensions In Inches	
	Min.	Max.	Min.	Max.
A	1.350	1.750	0.053	0.069
A1	0.100	0.250	0.004	0.010
A2	1.350	1.550	0.053	0.061
b	0.330	0.510	0.013	0.020
c	0.170	0.250	0.006	0.010
D	4.700	5.100	0.185	0.200
D1	3.100	3.500	0.122	0.137
E	3.800	4.000	0.150	0.157
E1	5.800	6.200	0.228	0.244
E2	2.200	2.600	0.086	0.102
e	1.270(BSC)		0.050(BSC)	
L	0.400	1.270	0.016	0.050
θ	0°	8°	0°	8°

DISCLAIMER

IMPORTANT NOTICE, PLEASE READ CAREFULLY

The information in this data sheet is intended to describe the operation and characteristics of our products. JSCJ has the right to make any modification, enhancement, improvement, correction or other changes to any content in this data sheet, including but not limited to specification parameters, circuit design and application information, without prior notice.

Any person who purchases or uses JSCJ products for design shall: 1. Select products suitable for circuit application and design; 2. Design, verify and test the rationality of circuit design; 3. Procedures to ensure that the design complies with relevant laws and regulations and the requirements of such laws and regulations. JSCJ makes no warranty or representation as to the accuracy or completeness of the information contained in this data sheet and assumes no responsibility for the application or use of any of the products described in this data sheet.

Without the written consent of JSCJ, this product shall not be used in occasions requiring high quality or high reliability, including but not limited to the following occasions: medical equipment, automotive electronics, military facilities and aerospace. JSCJ shall not be responsible for casualties or property losses caused by abnormal use or application of this product.

Official Website: www.jscj-elec.com

Copyright © JIANGSU CHANGJING ELECTRONICS TECHNOLOGY CO., LTD.