



## CJ6380 Series Low-dropout Regulators

### 1 Introduction

The CJ6380 device is a very high voltage tolerant linear regulator that is able to withstand continuous DC or transient input voltages of up to 50V and has an internal thermal shutdown and Short-Circuit protection to protect the system during fault conditions.

In addition, the CJ6380 device is ideal for generating a low-voltage supply from intermediate voltage rails in telecom and industrial applications; not only can it supply a well-regulated voltage rail, but it can also withstand and maintain regulation during very high and fast voltage transients. These features translate to simpler and more cost-effective electrical surge-protection circuitry for a wide range of applications, including PoE, bias supply, and LED lighting.

### 2 Available Packages

PARTNUMBER	PACKAGE
CJ6380 Series	SOT-23-3L
	SOT-23-5L
	SOT-89-3L
	SOT-223

**Note:** For all available packages, please refer to the part *Orderable Information*.

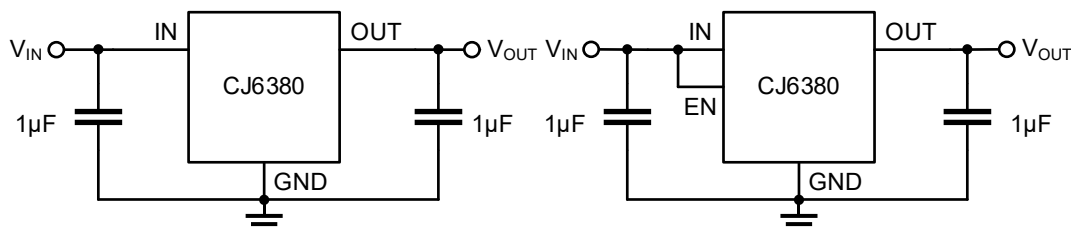

Typical Application Circuit

### 3 Features

- Very High Maximum Input Voltage: 50 V
- Wide Input Voltage Range: 3 to 50 V
- Output Voltage Range: 1.2V~12V
- Low Quiescent Current: 2.7  $\mu$ A
- Quiescent Current at Shutdown: 0.1  $\mu$ A
- Maximum Output Current: 200 mA
- CMOS Logic-Level-Compatible Enable Pin
- Dropout Voltage: 480mV@50mA
- Complete Protection:
  - Short circuit Protection, Thermal Shutdown
- Automatic Output Discharge at Shutdown
- Power Supply Rejection Ratio:
  - 88dB@1kHz, 76dB@10kHz
- Output Noise Voltage:
  - 20 x Vout  $\mu$ V<sub>RMS</sub>(10Hz~100kHz)

### 4 Applications

- Microprocessors, Microcontrollers Powered by Industrial Busses with High Voltage Transients
- Industrial Automation
- Automotive
- Power over Ethernet (PoE)
- LED Lighting
- Bias Power Supplies

5 Pin Configuration and Marking Information

5.1 Pin Configuration

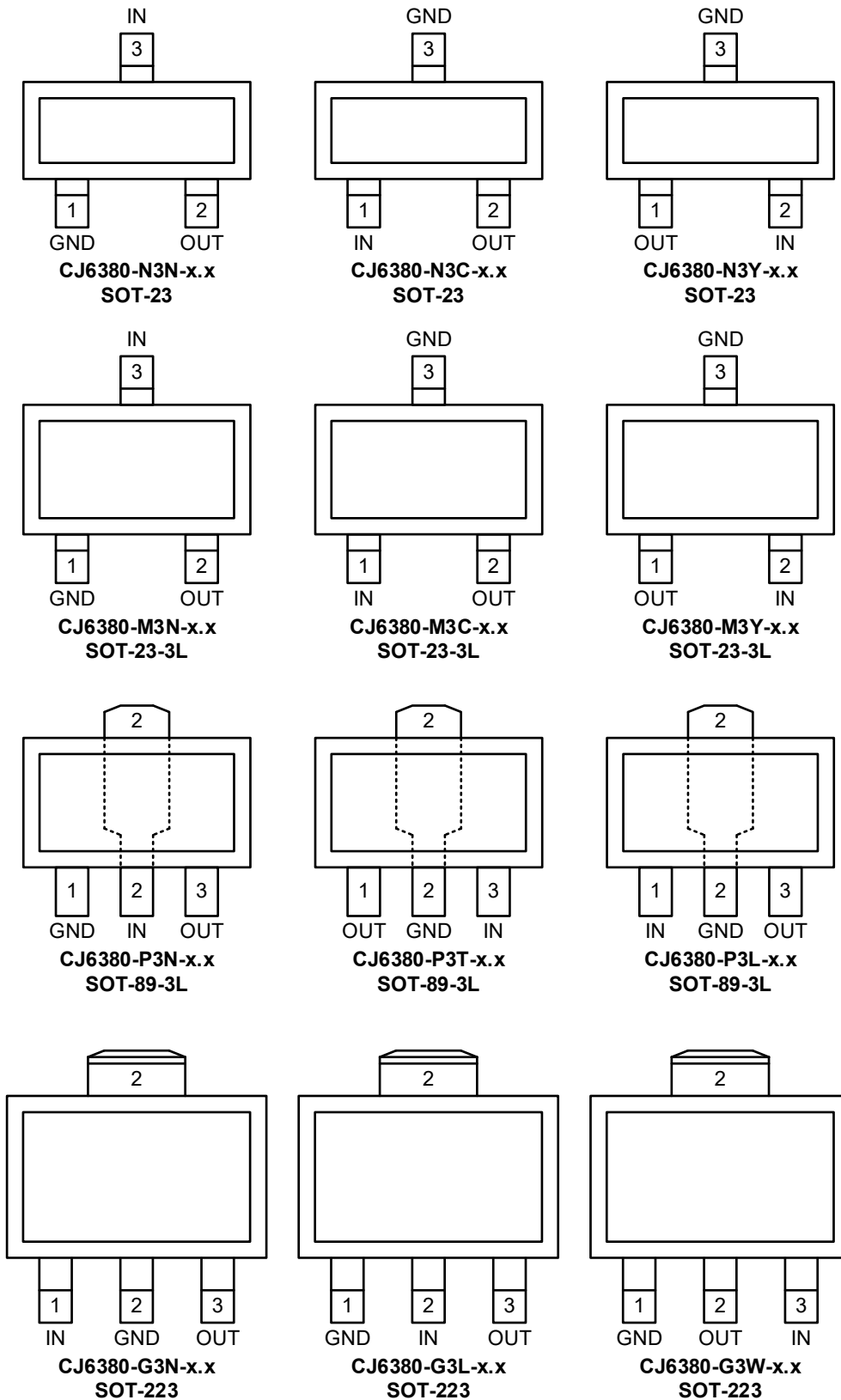

## 5 Pin Configuration and Marking Information

### 5.1 Pin Configuration

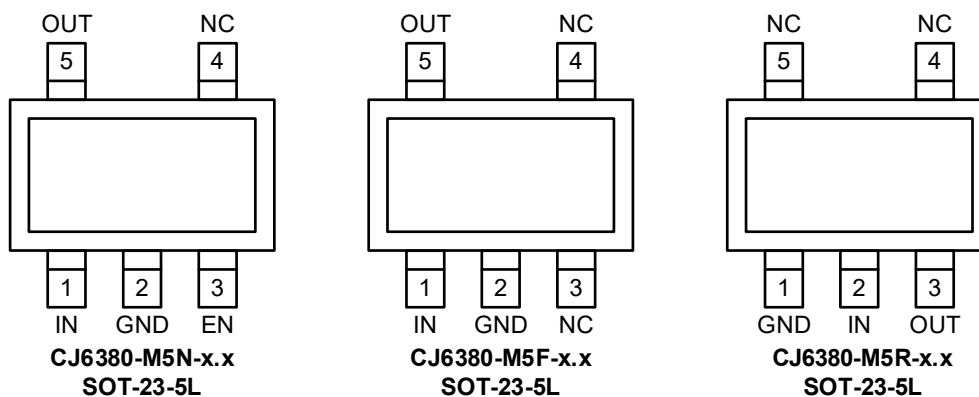

### 5.2 Pin Function

PIN NAME	I/O	CJ6380 Series Pin Function
		DESCRIPTION
OUT	O	Output of the regulator. An output capacitor is required for stability and help device obtain the best transient response. Use the capacitor with the recommended value and place it as close as possible to the output.
GND	-	Ground.
EN	I	Enable pin. Driving this pin to logic high enables the device; driving this Pin to logic low disables the device. Float this pin, disables the device.
IN	I	Input to the device. Use the recommended value of the input capacitor and place it as close to the input of the device as possible to reduce the impedance.
NC	-	No internal connection. This pin can float, but when this pin is connected to GND, the device has better thermal performance.

## 5 Pin Configuration and Marking Information

### 5.3 Marking Information

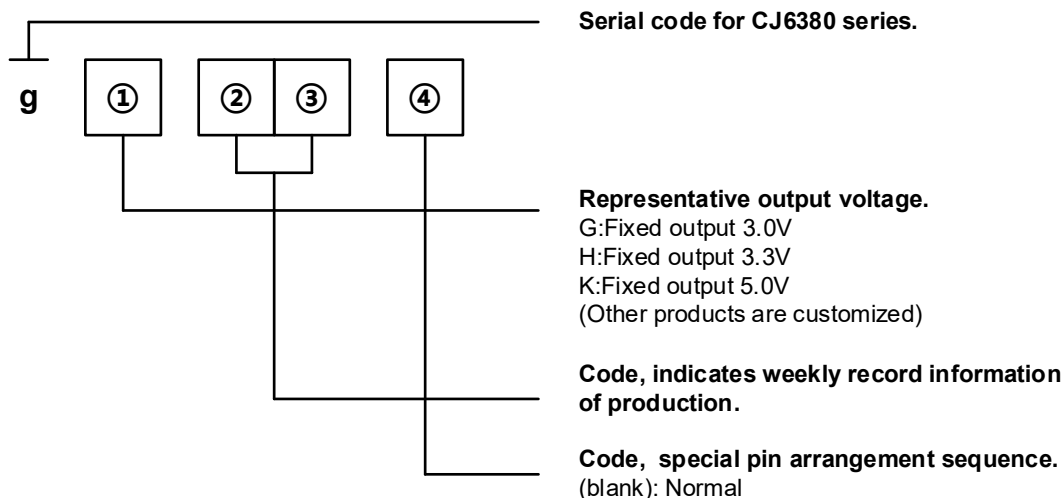

Figure 5-1. Marking Rule

Output Voltage	Marking Information for CJ6380 Series			
	3-Pins Packages			5-Pins Packages
	SOT-23-3L	SOT-89-3L	SOT-223	SOT-23-5L
3.3V	CJ6380-M3N-3.3: <b>gHXX</b>	CJ6380-P3N-3.3: <b>gHXX</b>	CJ6380-G3N-3.3: <b>gHXX</b>	CJ6380-M5N-3.3: <b>gHXX</b>
	CJ6380-M3N-3.3: <b>gHXXC</b>	CJ6380-P3T-3.3: <b>gHXXT</b>	CJ6380-G3L-3.3: <b>gHXXL</b>	CJ6380-M5F-3.3: <b>gHXXF</b>
	CJ6380-M3N-3.3: <b>gHXXY</b>	CJ6380-P3L-3.3: <b>gHXXL</b>	CJ6380-G3W-3.3: <b>gHXXW</b>	CJ6380-M5R-3.3: <b>gHXXF</b>
5.0V	CJ6380-M3N-5.0: <b>gKXX</b>	CJ6380-P3N-5.0: <b>gKXX</b>	CJ6380-G3N-5.0: <b>gKXX</b>	CJ6380-M5N-5.0: <b>gKXX</b>
	CJ6380-M3N-5.0: <b>gKXXC</b>	CJ6380-P3T-5.0: <b>gKXXT</b>	CJ6380-G3L-5.0: <b>gKXXL</b>	CJ6380-M5F-5.0: <b>gKXXF</b>
	CJ6380-M3N-5.0: <b>gKXXY</b>	CJ6380-P3L-5.0: <b>gKXXL</b>	CJ6380-G3W-5.0: <b>gKXXW</b>	CJ6380-M5R-5.0: <b>gKXXF</b>

**Note:**

The "XX" in the marking is composed of two capital letters, which indicates weekly record information of production. For example, the marking of CJ6380-M3N-3.3 is "gHXX", where "XX" is the weekly record code. The weekly record code may be different for products produced in different periods.

## 6 Specifications

### 6.1 Absolute Maximum Ratings

( $T_A = 25^\circ\text{C}$ , unless otherwise specified)<sup>(1)</sup>

CHARACTERISTIC		SYMBOL	VALUE	UNIT
Input voltage range <sup>(2)</sup>		$V_{IN}$	-0.3 ~ 50	V
Output voltage range <sup>(2)</sup>		$V_{OUT}$	-0.3 ~ 12	V
Enable voltage range <sup>(2)</sup>		$V_{EN}$	-0.3 ~ 60	V
Work temperature		$T_{op}$	-40 ~ +125	°C
Maximum power dissipation	CJ6380 Series	$P_{D\ Max}$	Internally Limited <sup>(3)</sup>	W
Maximum junction temperature		$T_J$	150	°C
Storage temperature		$T_{STG}$	-40 ~ +150	°C
Soldering temperature & time		$T_{solder}$	260°C, 10s	-

(1) Stresses beyond those listed under Absolute Maximum Ratings may cause permanent damage to the device. These are stress ratings only, which do not imply functional operation of the device at these or any other conditions beyond those indicated under Recommended Operating Conditions. Exposure to absolute maximum rated conditions for extended periods may affect device reliability.

(2) All voltages are with respect to network ground terminal.

(3) Refer to Thermal Information for details.

### 6.2 Recommended Operating Conditions

PARAMETER	SYMBOL	MIN.	NOM.	MAX.	UNIT
Input voltage	$V_{IN}$	3	-	60	V
Operating junction temperature	$T_J$	-40	-	150	°C
Operating ambient temperature	$T_A$	-40	-	125	°C

## 6 Specifications

### 6.3 ESD Ratings

ESD RATINGS		SYMBOL	VALUE	UNIT
Electrostatic discharge <sup>(4)</sup>	Human body model	V <sub>ESD-HBM</sub>	2500	V

(4) ESD testing is conducted in accordance with the relevant specifications formulated by the Joint Electronic Equipment Engineering Commission (JEDEC). The human body model (HBM) electrostatic discharge test is based on the JS-001-2017 test standard, using a 100pF capacitor and discharging to each pin of the device through a resistance of 1.5kΩ.

### 6.4 Thermal Information

THERMAL METRIC <sup>(5)</sup>	SYMBOL	CJ6380 Series			UNIT
		SOT-23	SOT-23-3L	SOT-89-3L	
Junction-to-ambient thermal resistance	R <sub>θJA</sub>				°C/W
		357.2	261.1	160.6	
		250.3	99.5	-	
Junction-to-case thermal resistance	R <sub>θJC</sub>				°C/W
		136.4	67.0	52.9	
		65.4	19.6	-	
Reference maximum power dissipation for continuous operation	P <sub>D Ref</sub>				W
		0.28	0.38	0.63	
		0.40	1.00	-	

(5) Thermal metric is measured in still air with TA = 25°C and mounted on a 1 in<sup>2</sup> FR-4 substrate PCB covered with 2 ounces of copper.

## 6 Specifications

### 6.5 Electrical Characteristics

**CJ6380 Series ( $V_{IN} = 5V$ ,  $C_{IN} = 1\mu F$ ,  $C_{OUT} = 1\mu F$ ,  $T_A = 25^\circ C$ , unless otherwise specified)**

CHARACTERISTIC	SYMBOL	TEST CONDITIONS		MIN.	TYP. <sup>(6)</sup>	MAX.	UNIT
Input voltage	$V_{IN}$	$T_A = 25^\circ C$		3	-	50	V
DC output tolerance	$V_{OUT}$	$T_J = 25^\circ C$ , $I_{OUT} = 1mA$		-1		+1	%
Available output voltage	-	-		1.2	-	12	V
Output current	$I_{OUT}^{(7)}$	-		-	200	-	mA
Quiescent current	$I_Q$	$I_{OUT} = 0mA$			2.7		$\mu A$
Line regulation	LNR <sup>(9)</sup>	$V_{IN} = V_{OUT} + 1V$ to 60V, $I_{OUT} = 5mA$			0.0048		%/V
Load regulation	LDR	$1mA \leq I_{OUT} \leq 200mA$			5		mV
Dropout voltage	$V_{DO}^{(8)}$	$I_{OUT} = 50mA$	$V_{OUT} = 3.3V$		480		mV
Shutdown current	$I_{SD}$	$V_{EN} \leq 0.4V$			0.11		$\mu A$
EN high	$V_{EN(H)}$	Turn on, stable output voltage		0.9			V
EN low	$V_{EN(L)}$	Turn off, output voltage is 0V				0.3	
EN Pull down current	$I_{EN}$	$V_{EN} = 5V$			0.07	0.2	$\mu A$
Power supply rejection ratio	PSRR	$I_{OUT} = 10mA$ , $V_{IN} = 12V$ , $V_{OUT} = 3.3V$	$f = 1kHz$		88		dB
			$f = 10kHz$		76		
			$f = 100kHz$		55		
			$f = 1MHz$		63		
Output noise voltage	$V_N$	$I_{OUT} = 10mA$ , $f = 10$ to 100kHz			$20 \times V_{out}$		$\mu V_{RMS}$
Short Circuit current		$V_{OUT} = 0$			45		mA
Thermal shutdown	$T_{SD}$			-	151	-	$^\circ C$
Thermal shutdown hysteresis	$\Delta T_{SD}$			-	20	-	$^\circ C$
$C_{OUT}$ auto-discharge resistance	$R_{DIS}$	$V_{EN} < 0.4$			73		$\Omega$
Load Transient		$I_{OUT} = 1 mA$ to 150 mA in 1 us $V_{OUT} = 3.3V$ , $V_{IN} = 12V$			-290		mV
		$I_{OUT} = 150 mA$ to 1 mA in 1 us $V_{OUT} = 3.3V$ , $V_{IN} = 12V$			+180		

**Note:**

(6) Typical numbers are at 25°C and represent the most likely norm.

(7) Maximum output current is affected by the PCB layout, metal trace width, number of layers, ambient temperature and other environmental factors. Thermal limitations of the system must be carefully considered.

(8) The line regulation is calculated by the following formula:  $LNR = \Delta V_{OUT} / (V_{OUT} \times \Delta V_{IN})$  where,  $\Delta V_{OUT}$  is the variation of the output voltage,  $\Delta V_{IN}$  is the variation of the input voltage.

(9) Test the difference of output voltage and input voltage when input voltage is decreased gradually till output voltage equals to 98% of  $V_{OUT}$  Normal.

6 Specifications

6.6 Typical Characteristics (continued)

CJ6380 Series,  $V_{OUT} = 3.3V$  ( $V_{IN} = 5V$ ,  $C_{IN} = 1\mu F$ ,  $C_{OUT} = 1\mu F$ ,  $T_A = 25^\circ C$ , unless otherwise specified)

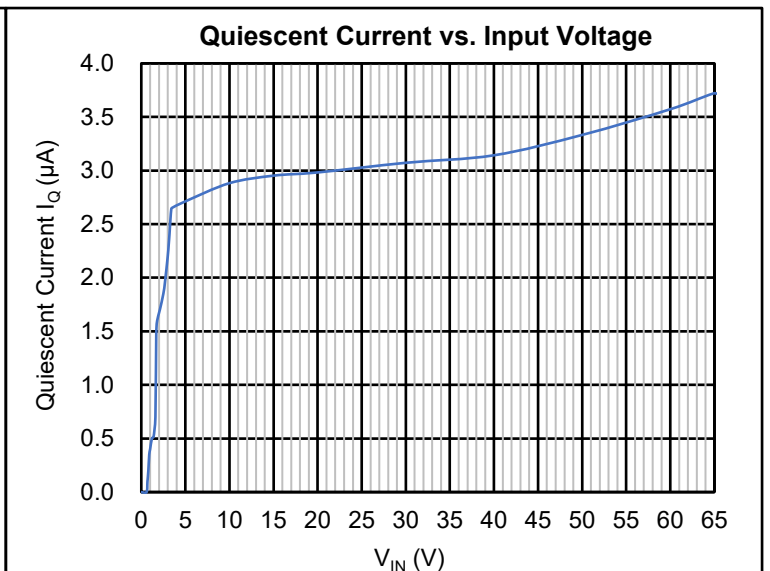
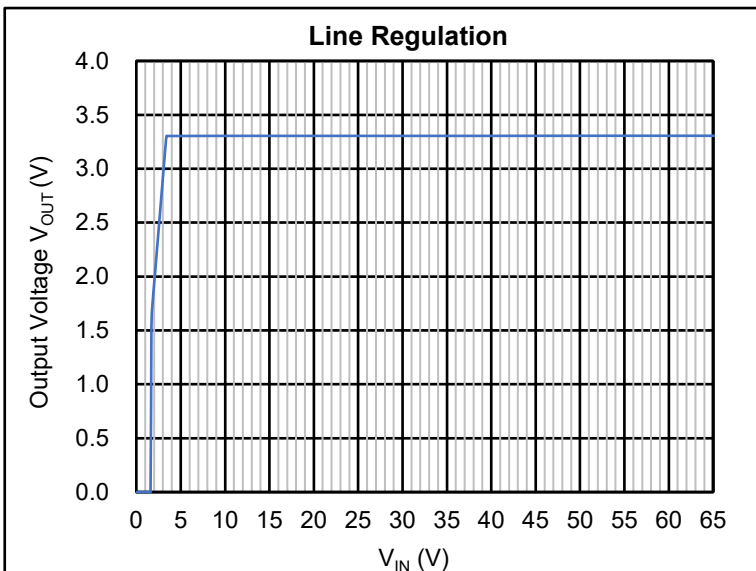
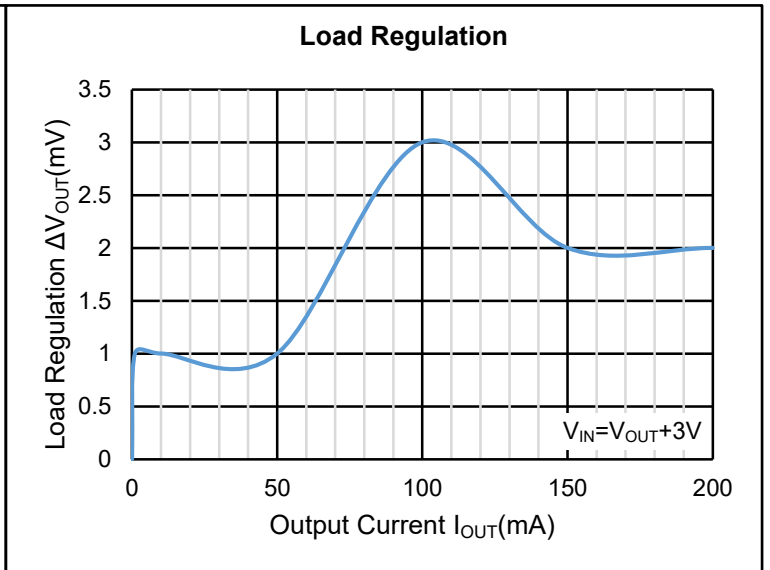
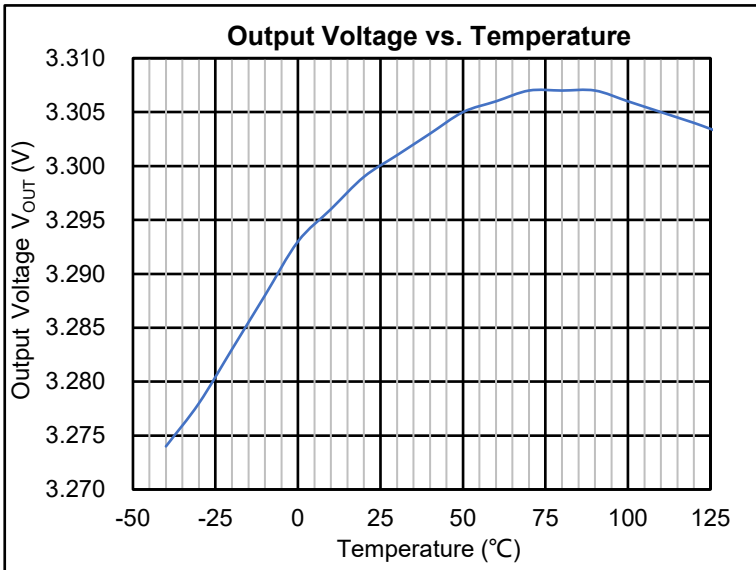
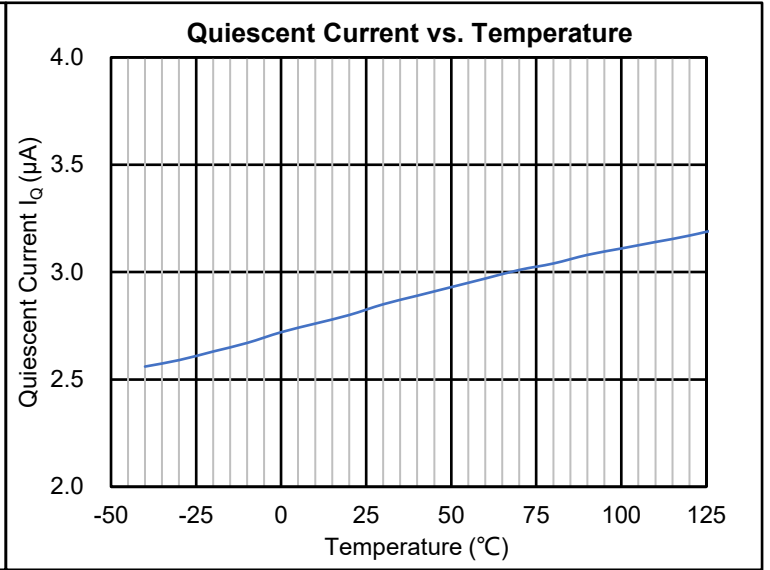
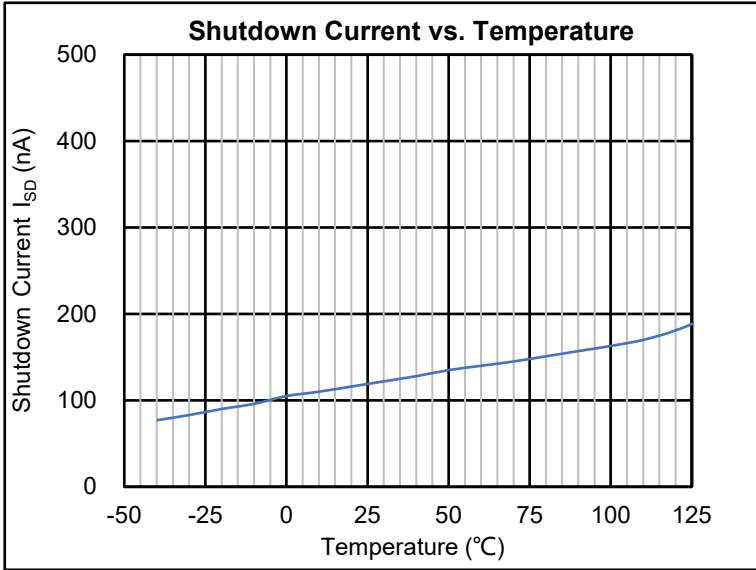

## 6 Specifications

### 6.6 Typical Characteristics (continued)

CJ6380 Series,  $V_{OUT} = 3.3V$  ( $V_{IN} = 5V$ ,  $C_{IN} = 1\mu F$ ,  $C_{OUT} = 1\mu F$ ,  $T_A = 25^\circ C$ , unless otherwise specified)

Dropout Voltage vs. Output Current

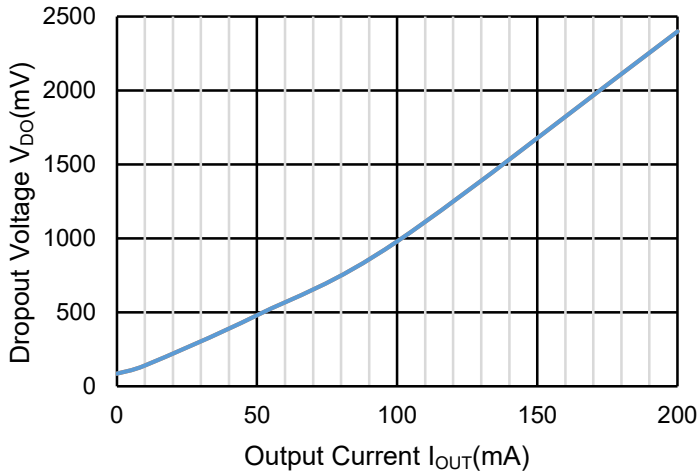

GND Current vs. Output Current

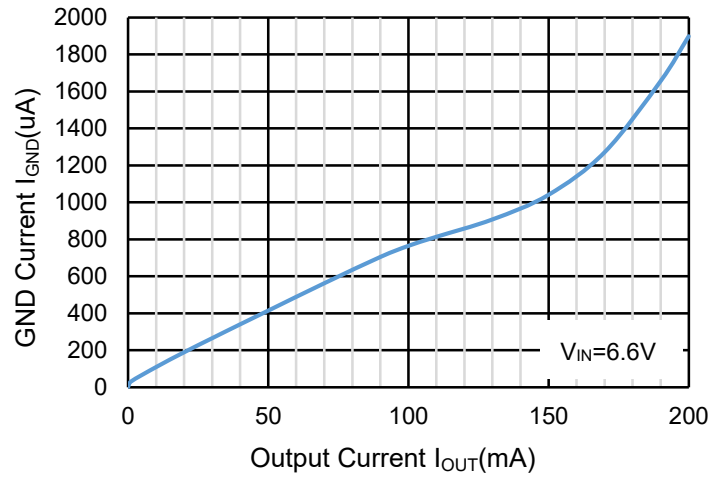

Power Supply Rejection Ratio

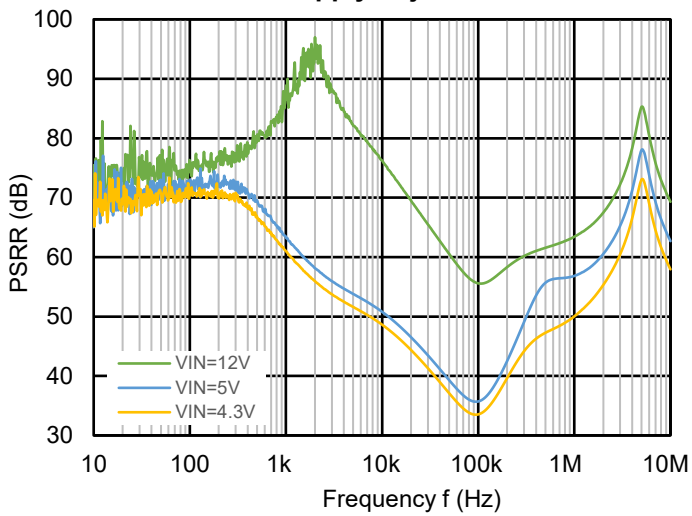

## 6 Specifications

### 6.6 Typical Characteristics (continued)

CJ6380 Series,  $V_{OUT} = 3.3V$  ( $V_{IN} = 5V$ ,  $C_{IN} = 1\mu F$ ,  $C_{OUT} = 1\mu F$ ,  $T_A = 25^\circ C$ , unless otherwise specified)

$V_{OUT} = 3.3V$ ,  $V_{IN} = 12V$

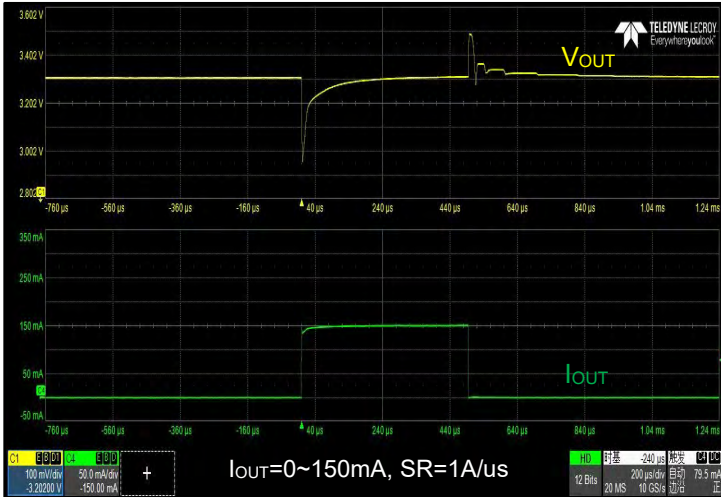

$V_{OUT} = 3.3V$ ,  $V_{IN} = 12V$

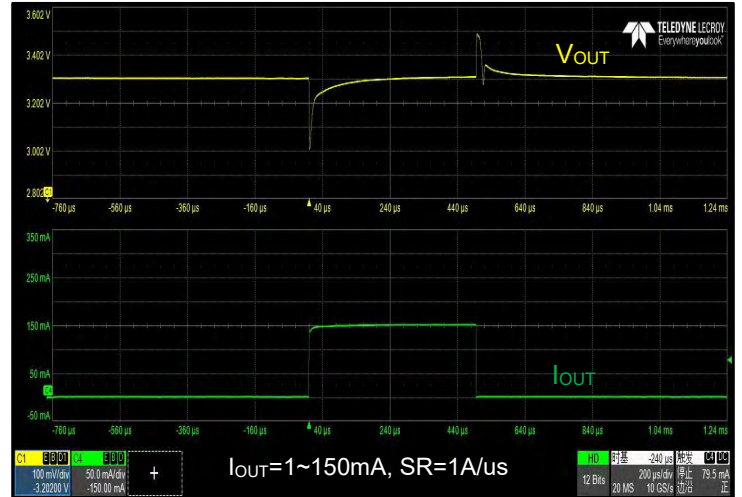

$V_{OUT} = 3.3V$ ,  $V_{IN} = 12V$ , Power On

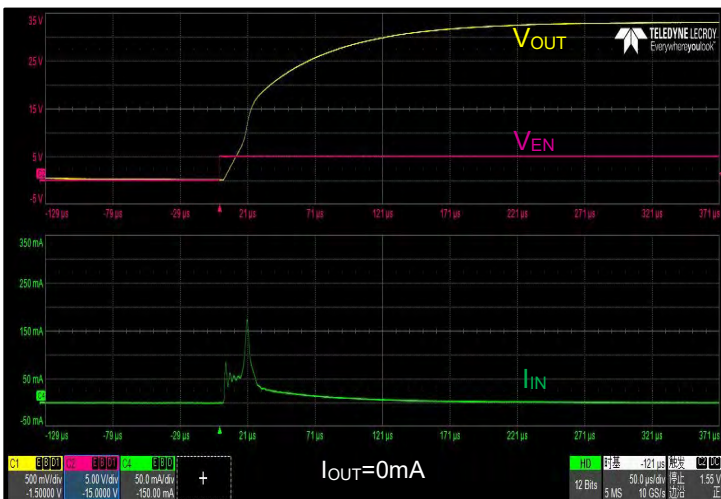

$V_{OUT} = 3.3V$ ,  $V_{IN} = 12V$ , Power On

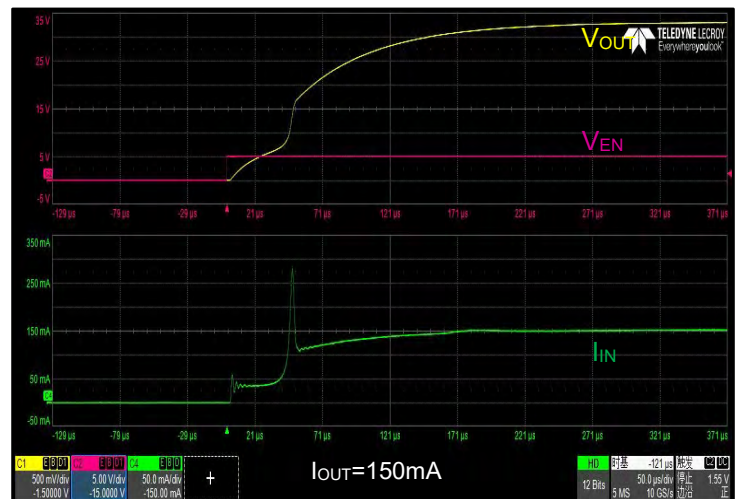

$V_{OUT} = 3.3V$ ,  $V_{IN} = 12V$ , Power Off



$V_{OUT} = 3.3V$ ,  $V_{IN} = 12V$ , Power Off

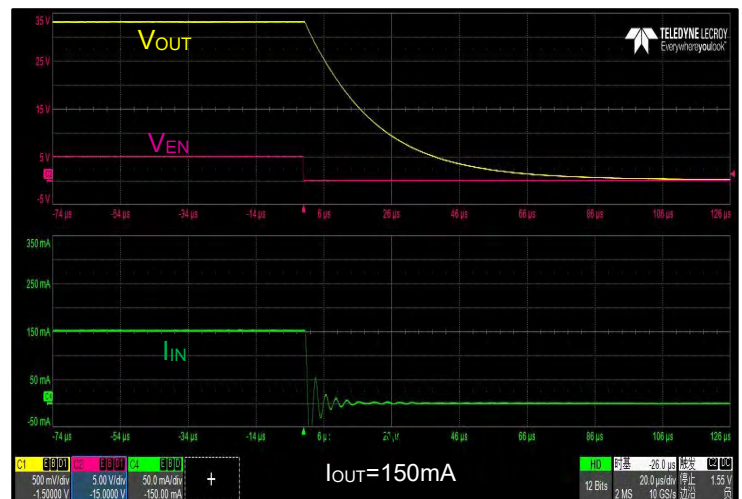

## 7 Detailed Description

### 7.1 Description

The CJ6380 device belongs to a new generation of linear regulators that use a BiCMOS process technology to achieve very high maximum input and output voltages. This process not only allows the CJ6380 device to maintain regulation during very fast high-voltage transients up to 50V, but it also allows the CJ6380 device to regulate from a continuous high-voltage input rail.

The output can be turned off by controlling the EN pin on the chip, and the power consumption after turning off is only below 0.12 $\mu$ A.

### 7.2 Function Block Diagram

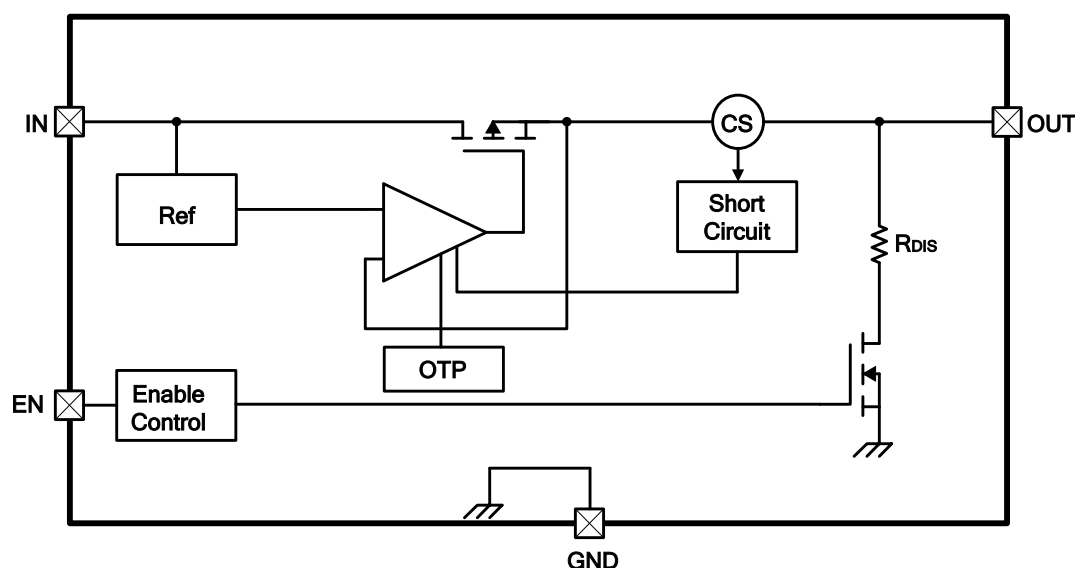

### 7.3 Feature Description

#### Dropout Voltage

Dropout voltage ( $V_{DO}$ ) refers to the minimum voltage difference between input and output ( $V_{IN}-V_{OUT}$ ) to make the device output voltage reach the rated range at rated current. When the dropout voltage condition required by the device is reached, the internal MOSFET will be fully turned on, at this time, the MOSFET is equivalent to a switch for regulation. The  $V_{DO}$  increases with the increase of load current. Since  $V_{IN} - V_{OUT}$  must be no less than the  $V_{DO}$ , the  $V_{DO}$  indirectly specifies the minimum input voltage of devices under different load current conditions. If the  $V_{IN}-V_{OUT}$  is less than the  $V_{DO}$ , the performance of the device may deteriorate (see *Operation in Dropout Mode* for details).

#### Input and Output Capacitors

For the CJ6380 series, it is recommended to use 1 $\mu$ F input  $C_{IN}$  and output  $C_{OUT}$  ceramic capacitors. It is recommended to use a 1 $\mu$ F capacitor at the input & Output pin of the device separately, and the position of the capacitor should be as close to the device pin as possible. Since any leakage of the capacitor will increase the quiescent power consumption of the whole circuit, attention should be paid to selecting capacitors with low leakage. When designing the circuit of portable equipment including CJ6380 series, due to the shortage of tantalum capacitors, it is a good choice to use small size, low equivalent series resistance (ESR) and high RMS current capacity multilayer ceramic capacitors (MLCC) in the DC to DC voltage conversion. The designer must choose the appropriate capacitor type for circuit design: X7R- Ceramic capacitors of X5R- and COG- rated dielectric materials can provide relatively good capacitance stability within the temperature range, Y5V- type capacitors are not recommended because of large changes in capacitance values. However, no matter which type of ceramic capacitor is selected, the effective capacitance may vary with the operating voltage and temperature. The designer must consider the influence of the change of the effective value of capacitance according to the circuit design and application conditions.

## 7 Detailed Description

### 7.3 Feature Description (continued)

#### Enable Operation

The enable pin will turn the regulator on or off. The threshold limits are covered in the electrical characteristics table in this data sheet. If the enable function is not to be used then the pin should be connected to  $V_{IN}$ .

#### Short-Circuit protection

The internal Foldback Current Limitation circuitry allows the device to supply the full nominal current but protects the device against Short. Foldback is a current-limiting feature that reduces the output current as the output voltage decreases in the event of an overcurrent condition. When  $V_{OUT}$  has decreased to 0 V, the current is limited to an internally set constant value. When a fault condition causing overcurrent disappears, an LDO automatically recovers from overcurrent protection, returning the output voltage to the normal level.

#### Thermal Protection

Internal thermal shutdown (TSD) circuitry is provided to protect the integrated circuit in the event that the maximum junction temperature is exceeded. When TSD activated, the regulator output turns off. When cooling down under the low temperature threshold, device output is activated again. This TSD feature is provided to prevent failures from accidental overheating. Activation of the thermal protection circuit indicates excessive power dissipation or inadequate heatsinking. For reliable operation, junction temperature should be limited to +151°C maximum.

## 8 Application and Implementation

### 8.1 Application Information

#### Transient Response

Transient response refers to the change of system output from initial state to stable state under the action of typical signal input. For LDO, the designer should pay attention to the possible impact of linear transient response and load transient response on the system: linear transient response refers to the transient response of output to change when the input voltage changes, while load transient response refers to the transient response of output to change when the output current changes. The specific phenomenon is that the output voltage of the device will have a short spike, especially when the input voltage or output current changes greatly in a short time. This change is not only related to the performance of the chip itself, but also related to the change of output current, change rate and output capacitance:

1. When the output current increases, the output voltage of the device will decrease to a certain extent, and the larger output current will provide a higher current discharge path for the output capacitor, which will affect the peak value generated by the transient spike and reduce the peak value;
2. The output current or input voltage changes relatively slowly, and the output change of the device is relatively small, affecting the spike caused by the change;
3. The use of large input and output capacitors can reduce the spike caused by transient response to a certain extent to improve the transient performance, but large output capacitors can also affect the response time of devices.

#### Operation in Dropout Mode

The CJ6380 series is internally integrated with a P-MOSFET to achieve low dropout voltage. The voltage difference between the input and the output  $V_{IN} - V_{OUT}$  of the device must not be lower than the corresponding dropout voltage  $V_{DO}$  to ensure that the output voltage tolerance is within the rated range of the data sheet. The dropout voltage will increase with the increase of load current. When the  $V_{IN} - V_{OUT}$  is less than the  $V_{DO}$ , the P-MOSFET inside the device is in a linear state, the resistance from the input pin to the output pin is equal to the resistance from the drain to the source of the P-MOSFET, and the device functions like a resistor. When operating in this state, the response time of the error amplifier inside the device will be limited, which will seriously degrade the transient performance of the device, when the external circuit has a transient change, the deviation of the output voltage will become larger than the normal operating state. In addition, the PSRR and noise performance of the device will be worse than that under normal operating conditions.

#### Recommended Continuous Operating Areas

As an LDO, the working area of CJ6380 series is limited by dropout voltage, output current, junction temperature and input voltage under continuous working condition. The recommended areas for continuous operation are shown in Figure 8-1:

- A. The LDO input and output voltage difference  $V_{IN} - V_{OUT}$  must meet the dropout voltage  $V_{DO}$  conditions. See *Dropout Voltage* for more details.
- B. Rated output current range  $I_{Rated}$ .
- C. The actual junction temperature  $T_J$  of LDO shall not exceed the rated junction temperature. The product of voltage difference and current at both ends of LDO is power consumption, which determines the actual working junction temperature of LDO, so the curve is not linear.

In addition, the working area of CJ6380 series is limited by the rated  $V_{IN MIN}$  and  $V_{IN MAX}$ .

## 8 Application and Implementation

### 8.1 Application Information (continued)

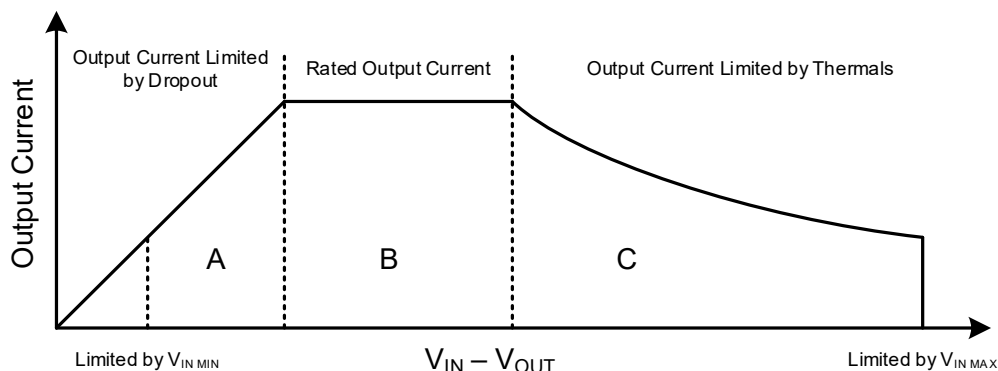

**Figure 8-1. Recommended areas for continuous operation**

### 8.2 Power Supply Recommendation

The CJ6380 series is designed to operate within the input power supply voltage range of 3.5V to 50V. The input power supply should be well adjusted and have low noise. If the input power supply has high noise, it is recommended to use an additional bypass capacitor at the input to improve the output noise performance of the device. It is recommended to use an input capacitor of 1 $\mu$ F or higher to reduce the impedance of the input power supply, especially during transients.

### 8.3 Layout Guidelines

When designing the circuit including CJ6380 series, the following matters should be noted:

- Place the input and output capacitors as close to the pins of the device as possible;
- The device is connected by copper plane and the heat sink (or back pad) of the device is fully welded with PCB to obtain better heat dissipation performance and lower on resistance;
- Heat sink holes are placed around the device to help the circuit dissipate more heat energy. However, attention should be paid to the position of the heat sink holes to prevent the solder (or solder paste) on the IC pad from being absorbed by the heat sink holes and being damaged during welding.

#### NOTE

The application information in this section is not part of the data sheet component specification, and JSCJ makes no commitment or statement to guarantee its accuracy or completeness. Customers are responsible for determining the rationality of corresponding components in their circuit design and making tests and verifications to ensure the normal realization of their circuit design.

## 9 Application and Implementation

### 9.1 Associated Product Family and Others

To view other products of the same type or IC products of other types, click the official website of JSCJ -- <https://www.jscj-elec.com> for more details.

### 9.2 Notes

#### Electrostatic Discharge Caution



This IC may be damaged by ESD. Relevant personnel shall comply with correct installation and use specifications to avoid ESD damage to the IC. If appropriate measures are not taken to prevent ESD damage, the hazards caused by ESD include but are not limited to degradation of integrated circuit performance or complete damage of integrated circuit. For some precision integrated circuits, a very small parameter change may cause the whole device to be inconsistent with its published specifications.

### 9.3 Revision History

April, 2025: released CJ6380 series rev - 1.0.

## 10 Orderable, Mechanical, and Packaging Information

The following pages include mechanical packaging and orderable information. This information is the most current data available for the designated devices. This data is subject to change without notice and revision of this document. For browser based versions of this data sheet, refer to the left hand navigation.

# DISCLAIMER

## **IMPORTANT NOTICE, PLEASE READ CAREFULLY**

The information in this data sheet is intended to describe the operation and characteristics of our products. JSCJ has the right to make any modification, enhancement, improvement, correction or other changes to any content in this data sheet, including but not limited to specification parameters, circuit design and application information, without prior notice.

Any person who purchases or uses JSCJ products for design shall: 1. Select products suitable for circuit application and design; 2. Design, verify and test the rationality of circuit design; 3. Procedures to ensure that the design complies with relevant laws and regulations and the requirements of such laws and regulations. JSCJ makes no warranty or representation as to the accuracy or completeness of the information contained in this data sheet and assumes no responsibility for the application or use of any of the products described in this data sheet.

Without the written consent of JSCJ, this product shall not be used in occasions requiring high quality or high reliability, including but not limited to the following occasions: medical equipment, military facilities and aerospace. JSCJ shall not be responsible for casualties or property losses caused by abnormal use or application of this product.

Official Website: [www.jscj-elec.com](http://www.jscj-elec.com)

Copyright © JIANGSU CHANGJING ELECTRONICS TECHNOLOGY CO., LTD.

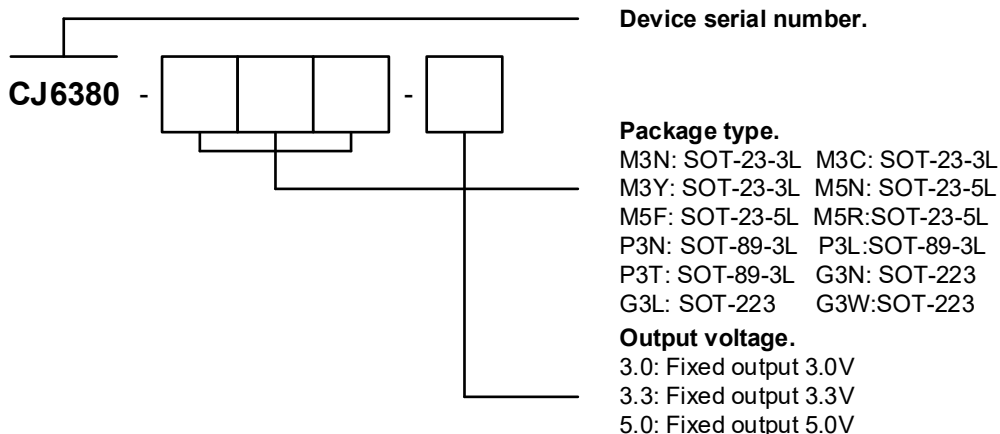
**Figure A-1. Naming Conventions**

MODEL	DEVICE	PACKAGE	OP TEMP	ECO PLAN	MSL	PACKING OPTION	SORT
<b>3 Pins Packaged Products</b>							
CJ6380-3.3	CJ6380-M3N-3.3	SOT-23-3L	-40 ~ 125°C	RoHS & Green	Level 3 168 HR	Tape and Reel 3000 Units / Reel	Active
CJ6380-5.0	CJ6380-M3N-5.0	SOT-23-3L	-40 ~ 125°C	RoHS & Green	Level 3 168 HR	Tape and Reel 3000 Units / Reel	Active
CJ6380-3.3	CJ6380-P3N-3.3	SOT-89-3L	-40 ~ 125°C	RoHS & Green	Level 3 168 HR	Tape and Reel 1000 Units / Reel	Active
CJ6380-5.0	CJ6380-P3N-5.0	SOT-89-3L	-40 ~ 125°C	RoHS & Green	Level 3 168 HR	Tape and Reel 1000 Units / Reel	Active
CJ6380-3.3	CJ6380-P3T-3.3	SOT-89-3L	-40 ~ 125°C	RoHS & Green	Level 3 168 HR	Tape and Reel 1000 Units / Reel	Active
CJ6380-5.0	CJ6380-P3T-5.0	SOT-89-3L	-40 ~ 125°C	RoHS & Green	Level 3 168 HR	Tape and Reel 1000 Units / Reel	Active
CJ6380-3.3	CJ6380-G3N-3.3	SOT-223	-40 ~ 125°C	RoHS & Green	Level 3 168 HR	Tape and Reel 2500 Units / Reel	Active
CJ6380-5.0	CJ6380-G3N-5.0	SOT-223	-40 ~ 125°C	RoHS & Green	Level 3 168 HR	Tape and Reel 2500 Units / Reel	Active

## Orderable Information

MODEL	DEVICE	PACKAGE	OP TEMP	ECO PLAN	MSL	PACKING OPTION	SORT
<b>5 Pins Packaged Products</b>							
CJ6380-3.3	CJ6380-M5N-3.3	SOT-23-5L	-40 ~ 125°C	RoHS & Green	Level 3 168 HR	Tape and Reel 3000 Units / Reel	Active
CJ6380-5.0	CJ6380-M5N-5.0	SOT-23-5L	-40 ~ 125°C	RoHS & Green	Level 3 168 HR	Tape and Reel 3000 Units / Reel	Active
<b>Customized Products</b>							
Others	-	-	-	-	-	-	Customized

**Note:**

**ECO PLAN:** For the RoHS and Green certification standards of this product, please refer to the official report provided by JSCJ.

**MSL:** Moisture Sensitivity Level. Determined according to JEDEC industry standard classification.

**SORT:** Specifically defined as follows:

Active: Recommended for new products;

Customized: Products manufactured to meet the specific needs of customers;

Preview: The device has been released and has not been fully mass produced. The sample may or may not be available;

NoRD: It is not recommended to use the device for new design. The device is only produced for the needs of existing customers;

Obsolete: The device has been discontinued.

## Mechanical Information

### SOT-23 Mechanical Information

#### SOT-23 Outline Dimensions

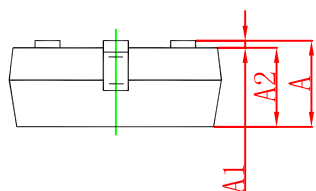
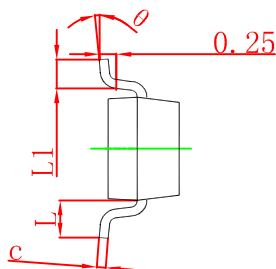
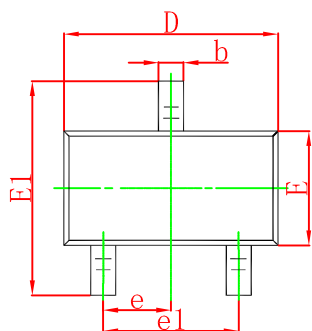

Symbol	Dimensions In Millimeters		Dimensions In Inches	
	Min	Max	Min	Max
A	0.900	1.150	0.035	0.045
A1	0.000	0.100	0.000	0.004
A2	0.900	1.050	0.035	0.041
b	0.300	0.500	0.012	0.020
c	0.080	0.150	0.003	0.006
D	2.800	3.000	0.110	0.118
E	1.200	1.400	0.047	0.055
E1	2.250	2.550	0.089	0.100
e	0.950 TYP		0.037 TYP	
e1	1.800	2.000	0.071	0.079
L	0.550 REF		0.022 REF	
L1	0.300	0.500	0.012	0.020
$\theta$	0°	8°	0°	8°

#### SOT-23 Suggested Pad Layout

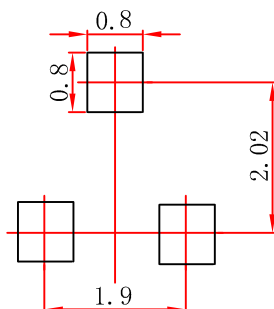

#### Note:

1. Controlling dimension: in millimeters.
2. General tolerance:  $\pm 0.05\text{mm}$ .
3. The pad layout is for reference purpose only.

## Mechanical Information

### SOT-23-3L Mechanical Information

#### SOT-23-3L Outline Dimensions

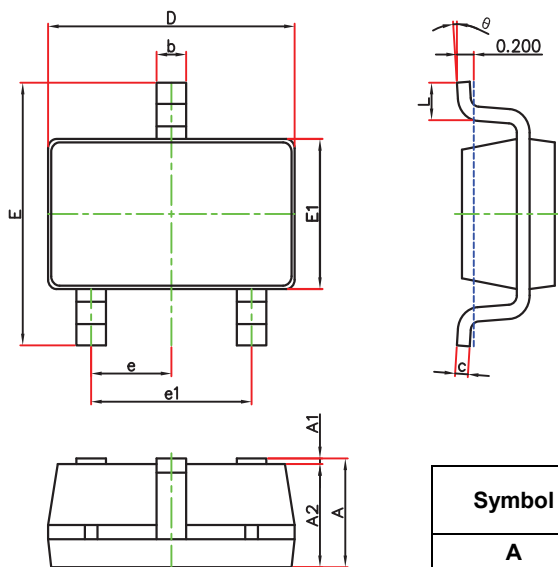

Symbol	Dimensions In Millimeters		Dimensions In Inches	
	Min.	Max.	Min.	Max.
A	1.050	1.250	0.041	0.049
A1	0.000	0.100	0.000	0.004
A2	1.050	1.150	0.041	0.045
b	0.300	0.500	0.012	0.020
c	0.100	0.200	0.004	0.008
D	2.820	3.020	0.111	0.119
E	2.650	2.950	0.104	0.116
E1	1.500	1.700	0.059	0.067
e	0.950(BSC)		0.037(BSC)	
e1	1.800	2.000	0.071	0.079
L	0.300	0.600	0.012	0.024
θ	0°	8°	0°	8°

#### SOT-23-3L Suggested Pad Layout

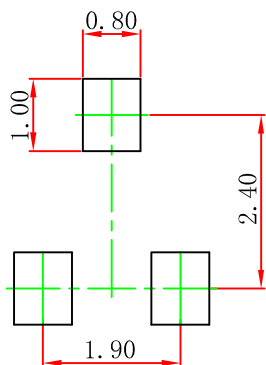

#### Note:

1. Controlling dimension: in millimeters.
2. General tolerance:  $\pm 0.05\text{mm}$ .
3. The pad layout is for reference purpose only.

## Mechanical Information

### SOT-89-3L Mechanical Information

#### SOT-89-3L Outline Dimensions

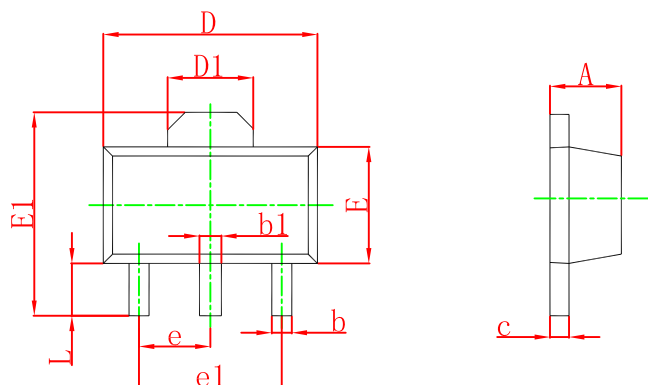

Symbol	Dimensions In Millimeters		Dimensions In Inches	
	Min.	Max.	Min.	Max.
A	1.400	1.600	0.055	0.063
b	0.320	0.520	0.013	0.197
b1	0.400	0.580	0.016	0.023
c	0.350	0.440	0.014	0.017
D	4.400	4.600	0.173	0.181
D1	1.550 REF		0.061 REF	
E	2.300	2.600	0.091	0.102
E1	3.940	4.250	0.155	0.167
e	1.500 TYP		0.060 TYP	
e1	3.000 TYP		0.118 TYP	
L	0.900	1.200	0.035	0.047

#### SOT-89-3L Suggested Pad Layout

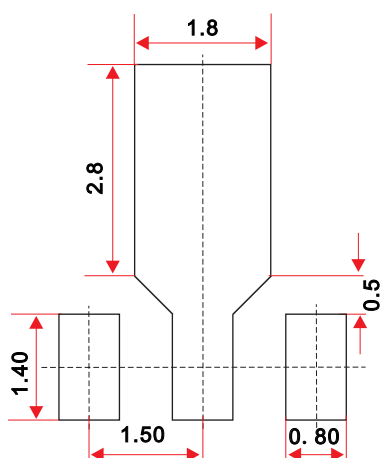

#### Note:

1. Controlling dimension: in millimeters.
2. General tolerance:  $\pm 0.05\text{mm}$ .
3. The pad layout is for reference purpose only.

## Mechanical Information

### SOT-223 Mechanical Information

#### SOT-223 Outline Dimensions

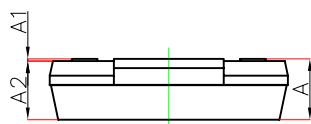
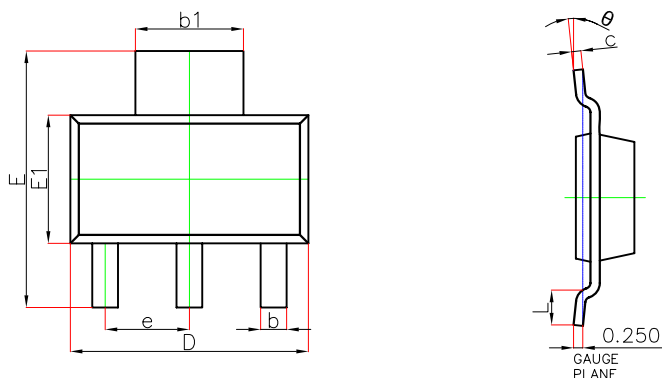

Symbol	Dimensions In Millimeters		Dimensions In Inches	
	Min.	Max.	Min.	Max.
A	—	1.800	—	0.071
A1	0.020	0.100	0.001	0.004
A2	1.500	1.700	0.059	0.067
b	0.660	0.840	0.026	0.033
b1	2.900	3.100	0.114	0.122
c	0.230	0.350	0.009	0.014
D	6.300	6.700	0.248	0.264
E	6.700	7.300	0.264	0.287
E1	3.300	3.700	0.130	0.146
e	2.300(BSC)		0.091(BSC)	
L	0.750	—	0.030	—
θ	0°	10°	0°	10°

#### SOT-223 Suggested Pad Layout

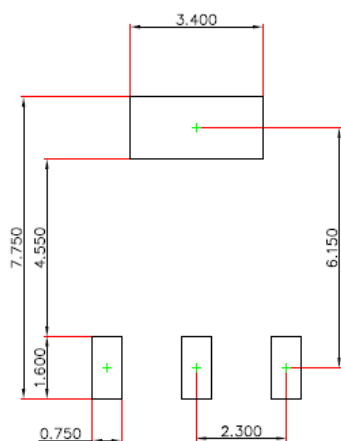

#### Note:

1. Controlling dimension: in millimeters.
2. General tolerance:  $\pm 0.05\text{mm}$ .
3. The pad layout is for reference purpose only.

## Mechanical Information

### SOT-23-5L Mechanical Information

#### SOT-23-5L Outline Dimensions

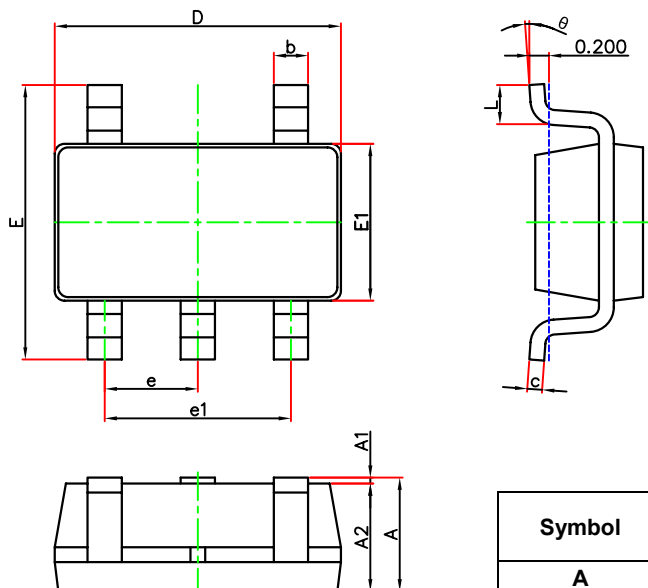

Symbol	Dimensions In Millimeters		Dimensions In Inches	
	Min.	Max.	Min.	Max.
A	1.050	1.250	0.041	0.049
A1	0.000	0.100	0.000	0.004
A2	1.050	1.150	0.041	0.045
b	0.300	0.500	0.012	0.020
c	0.100	0.200	0.004	0.008
D	2.820	3.020	0.111	0.119
E	2.650	2.950	0.104	0.116
E1	1.500	1.700	0.059	0.067
e	0.950(BSC)		0.037(BSC)	
e1	1.800	2.000	0.071	0.079
L	0.300	0.600	0.012	0.024
θ	0°	8°	0°	8°

#### SOT-23-5L Suggested Pad Layout

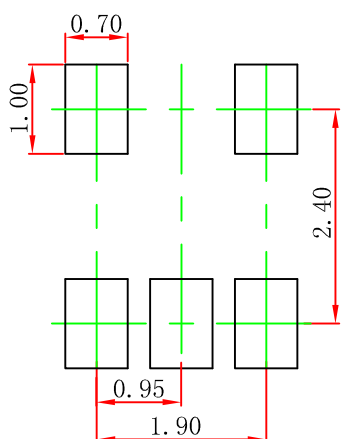

#### Note:

1. Controlling dimension: in millimeters.
2. General tolerance:  $\pm 0.05\text{mm}$ .
3. The pad layout is for reference purpose only.

## Packaging Information

### SOT-23 Tape and Reel Information

#### SOT-23 Embossed Carrier Tape

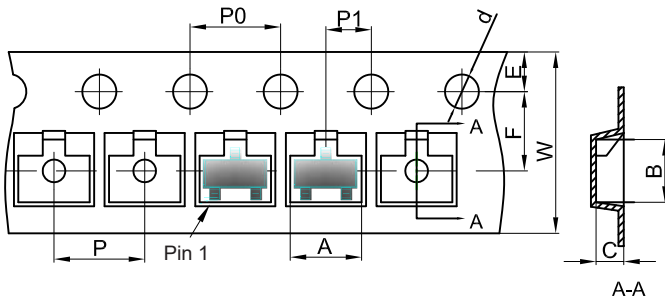

#### Packaging Description:

SOT-23 parts are shipped in tape. The carrier tape is made from a dissipative (carbon filled) polycarbonate resin. The cover tape is a multilayer film (Heat Activated Adhesive in nature) primarily composed of polyester film, adhesive layer, sealant, and anti-static sprayed agent. These reeled parts in standard option are shipped with 3,000 units per 7" or 17.8cm diameter reel. The reels are clear in color and is made of polystyrene plastic (anti-static coated).

Dimensions are in millimeter										
Pkg type	A	B	C	d	E	F	P0	P	P1	W
SOT-23	3.15	2.77	1.22	Ø1.50	1.75	3.50	4.00	4.00	2.00	8.00

#### SOT-23 Tape Leader and Trailer

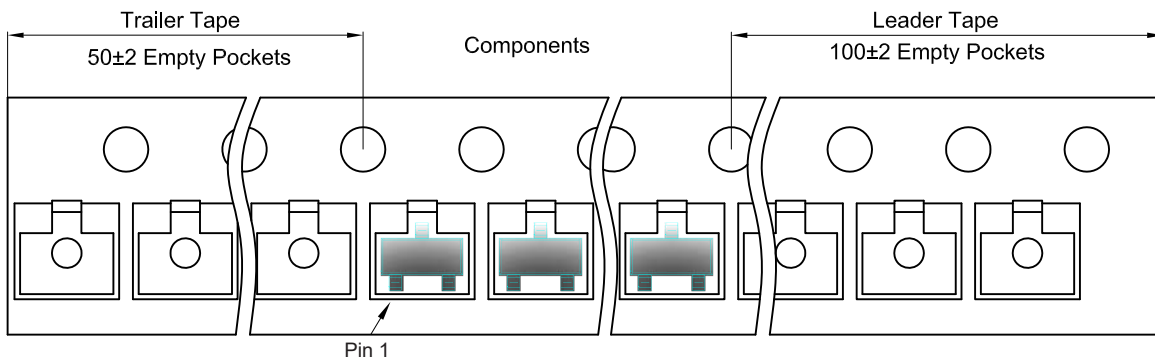

#### SOT-23 Reel

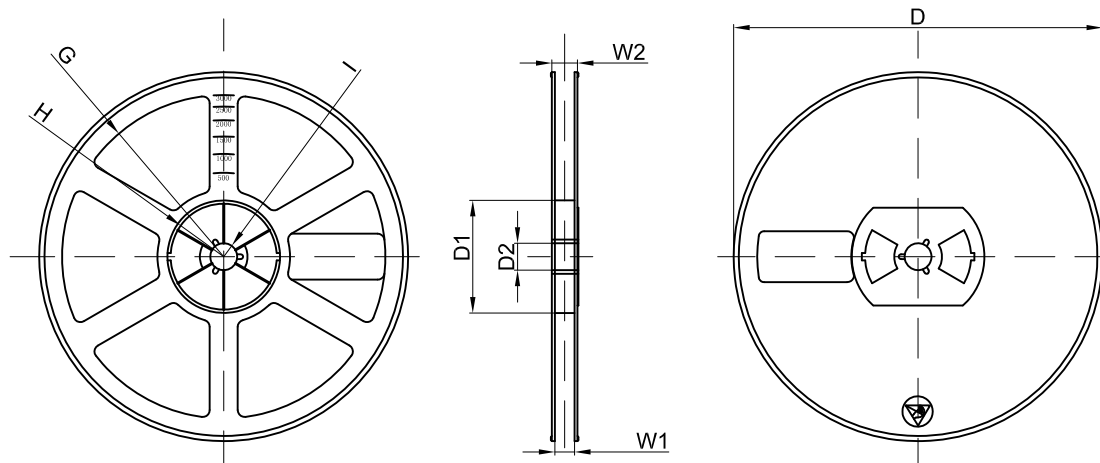

Dimensions are in millimeter								
Reel Option	D	D1	D2	G	H	I	W1	W2
7" Dia	Ø178.00	54.40	13.00	R78.00	R25.60	R6.50	9.50	12.30

REEL	Reel Size	Box	Box Size(mm)	Carton	Carton Size(mm)	G.W.(kg)
3000 pcs	7 inch	45,000 pcs	203×203×195	180,000 pcs	438×438×220	

Packaging Information

SOT-23-3L Tape and Reel Information

SOT-23-3L Embossed Carrier Tape

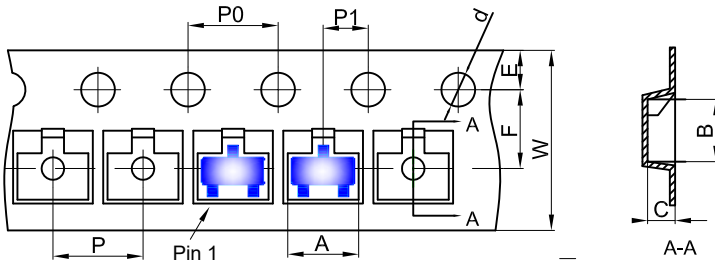

**Packaging Description:**  
 SOT-23-3L parts are shipped in tape. The carrier tape is made from a dissipative (carbon filled) polycarbonate resin. The cover tape is a multilayer film (Heat Activated Adhesive in nature) primarily composed of polyester film, adhesive layer, sealant, and anti-static sprayed agent. These reeled parts in standard option are shipped with 3,000 units per 7" or 18.0cm diameter reel. The reels are clear in color and is made of polystyrene plastic (anti-static coated).

Dimensions are in millimeter										
Pkg type	A	B	C	d	E	F	P0	P	P1	W
SOT-23-3L	3.18	3.28	1.32	Ø1.50	1.75	3.50	4.00	4.00	2.00	8.00

SOT-23-3L Tape Leader and Trailer

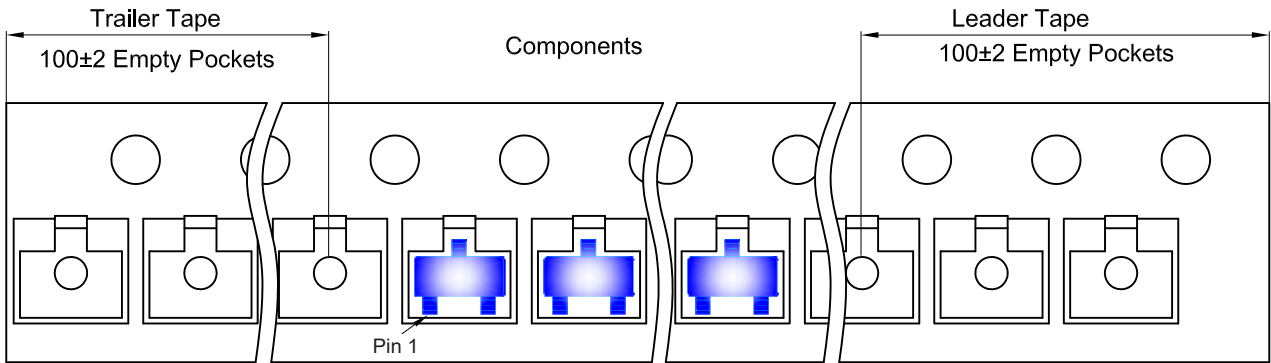

SOT-23-3L Reel

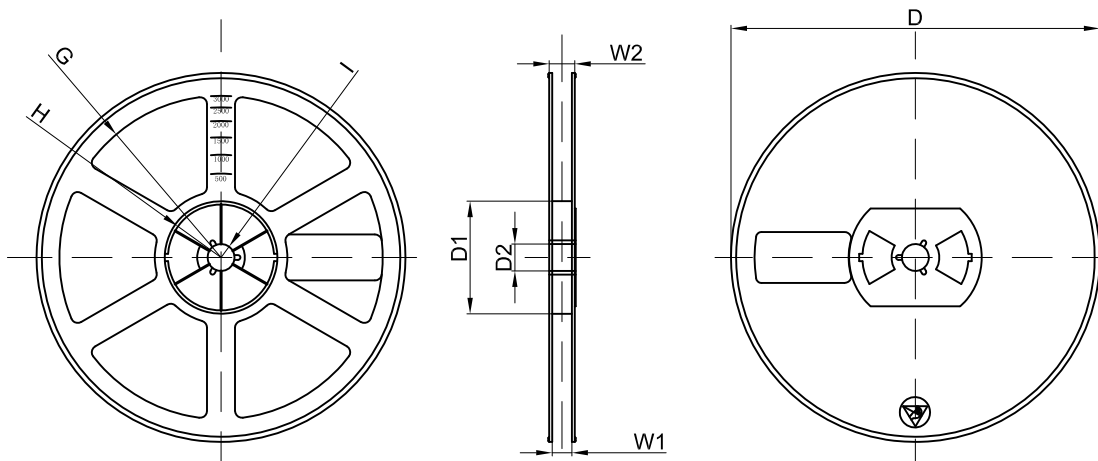

Dimensions are in millimeter								
Reel Option	D	D1	D2	G	H	I	W1	W2
7"Dia	Ø180.00	60.00	13.00	R78.00	R25.60	R6.50	9.50	13.10

REEL	Reel Size	Box	Box Size(mm)	Carton	Carton Size(mm)	G.W.(kg)
3000 pcs	7 inch	30,000 pcs	203×203×195	120,000 pcs	438×438×220	

Packaging Information

SOT-89-3L Tape and Reel Information

SOT-89-3L Embossed Carrier Tape

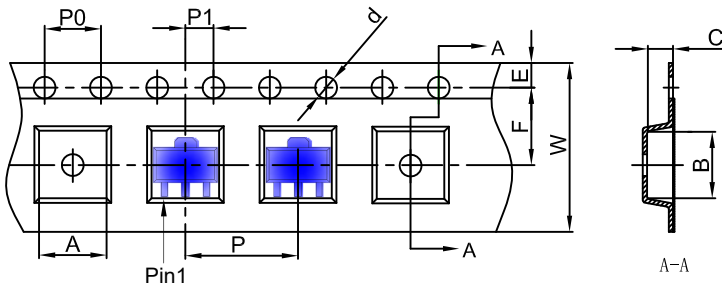

**Packaging Description:**  
 SOT-89-3L parts are shipped in tape. The carrier tape is made from a dissipative (carbon filled) polycarbonate resin. The cover tape is a multilayer film (Heat Activated Adhesive in nature) primarily composed of polyester film, adhesive layer, sealant, and anti-static sprayed agent. These reeled parts in standard option are shipped with 1,000 units per 7" or 18.0 cm diameter reel. The reels are clear in color and is made of polystyrene plastic (anti-static coated).

Dimensions are in millimeter										
Pkg type	A	B	C	d	E	F	P0	P	P1	W
SOT-89-3L	4.85	4.45	1.85	Ø1.50	1.75	5.50	4.00	8.00	2.00	12.00

SOT-89-3L Tape Leader and Trailer

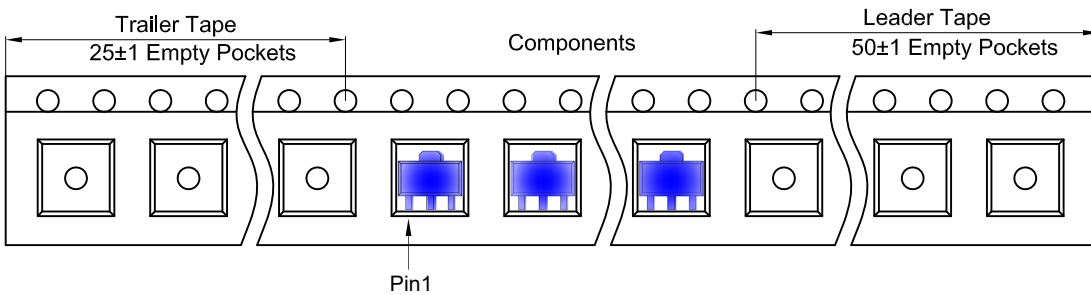

SOT-89-3L Reel

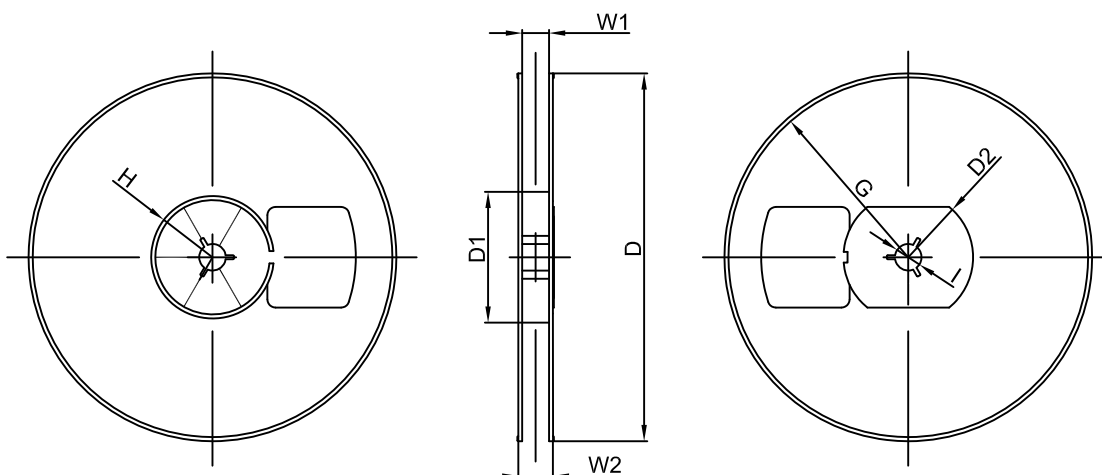

Dimensions are in millimeter								
Reel Option	D	D1	D2	G	H	I	W1	W2
7" Dia	Ø180.00	60.00	R32.00	R86.50	R30.00	Ø13.00	13.20	16.50

REEL	Reel Size	Box	Box Size(mm)	Carton	Carton Size(mm)	G.W.(kg)
1000 pcs	7 inch	10,000 pcs	203×203×195	40,000 pcs	438×438×220	

**Packaging Information**

**SOT-223 Tape and Reel Information**

**SOT-223 Embossed Carrier Tape**

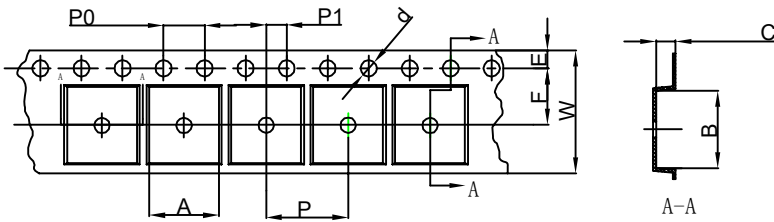

**Packaging Description:**  
 SOT-223 parts are shipped in tape. The carrier tape is made from a dissipative (carbon filled) polycarbonate resin. The cover tape is a multilayer film (Heat Activated Adhesive in nature) primarily composed of polyester film, adhesive layer, sealant, and anti-static sprayed agent. These reeled parts in standard option are shipped with 2,500 units per 13" or 33.0cm diameter reel. The reels are clear in color and is made of polystyrene plastic (anti-static coated).

Dimensions are in millimeter										
Pkg type	A	B	C	d	E	F	P0	P	P1	W
SOT-223	6.765	7.335	1.88	Ø1.50	1.75	5.50	4.00	8.00	2.00	12.00

**SOT-223 Tape Leader and Trailer**

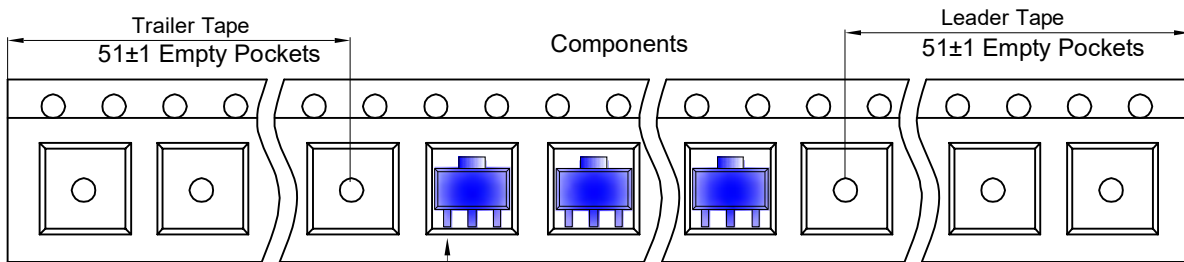

**SOT-223 Reel**

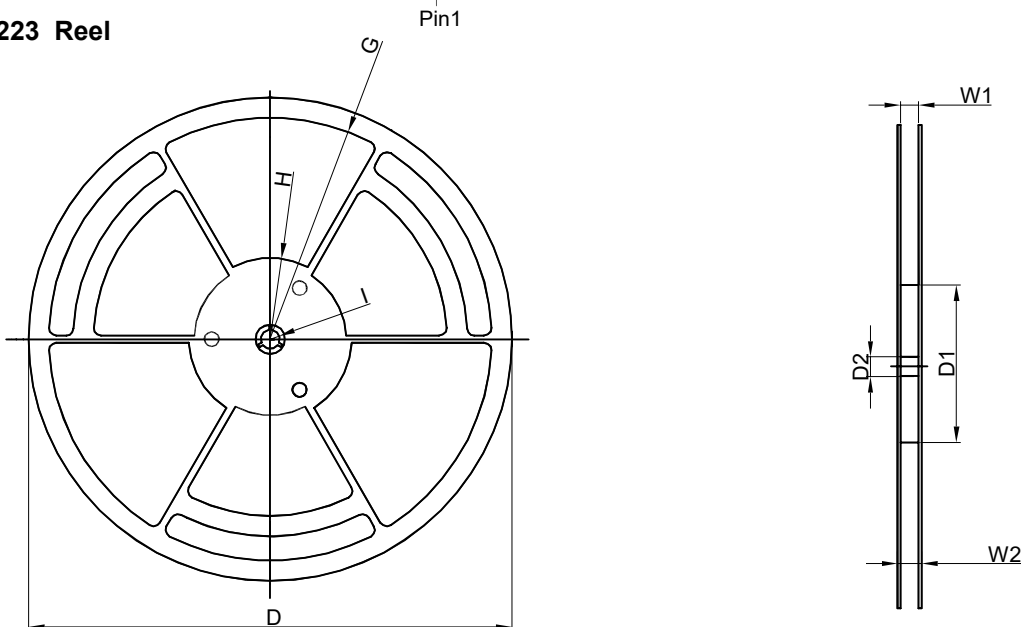

Dimensions are in millimeter								
Reel Option	D	D1	D2	G	H	I	W1	W2
13" Dia	Ø330.00	100.00	13.00	R151.00	R56.00	R6.50	12.40	17.60

REEL	Reel Size	Box	Box Size(mm)	Carton	Carton Size(mm)	G.W.(kg)
2,500 pcs	13 inch	2,500 pcs	336×336×48	20,000 pcs	445×355×365	

## Packaging Information

### SOT-23-5L Tape and Reel Information

### SOT-23-5L Tape and Reel Information

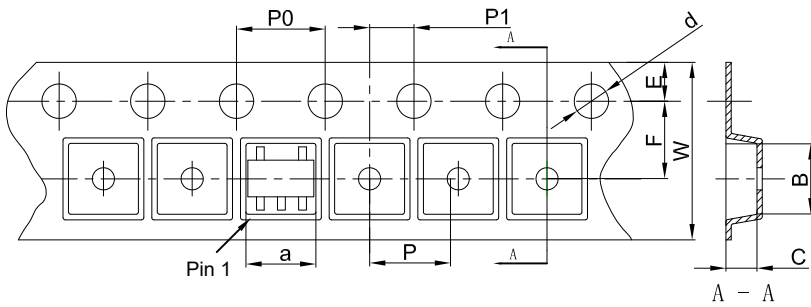

#### Packaging Description:

SOT-23-5L parts are shipped in tape. The carrier tape is made from a dissipative (carbon filled) polycarbonate resin. The cover tape is a multilayer film (Heat Activated Adhesive in nature) primarily composed of polyester film, adhesive layer, sealant, and anti-static sprayed agent. These reeled parts in standard option are shipped with 3,000 units per 7" or 18.0cm diameter reel. The reels are clear in color and is made of polystyrene plastic (anti-static coated).

Dimensions are in millimeter										
Pkg type	a	B	C	d	E	F	P0	P	P1	W
SOT-23-5L	3.17	3.23	1.37	Ø1.55	1.75	3.50	4.00	4.00	2.00	8.00

### SOT-23-5L Tape Leader and Trailer

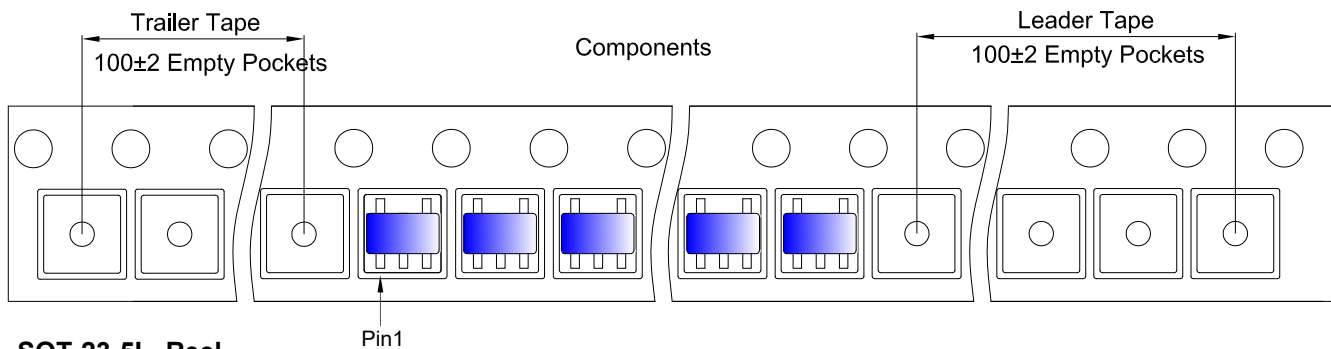

### SOT-23-5L Reel

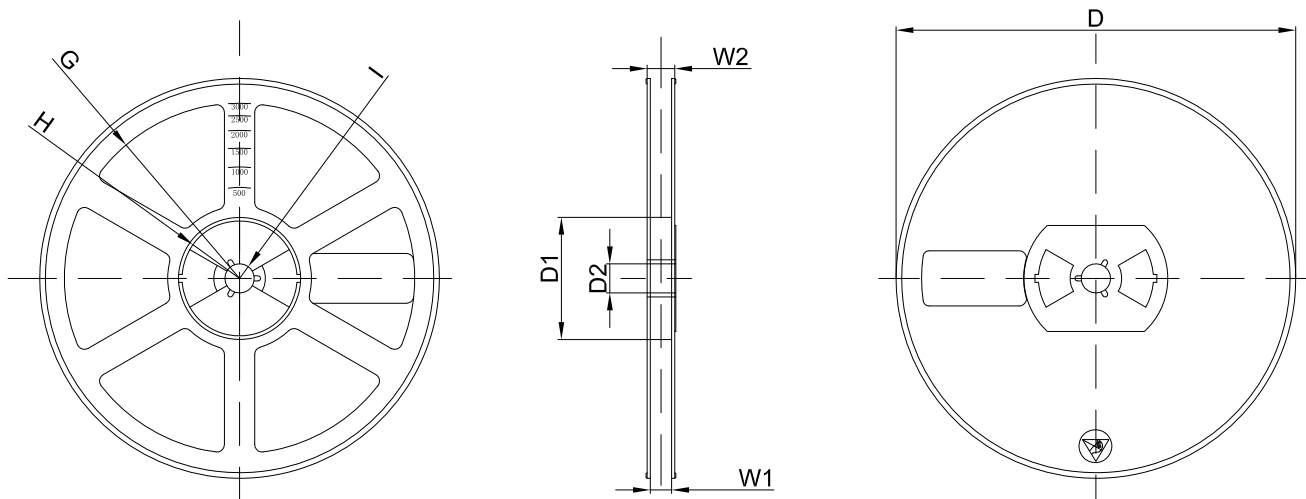

Dimensions are in millimeter								
Reel Option	D	D1	D2	G	H	I	W1	W2
7" Dia	Ø180.00	60.00	13.00	R78.00	R25.60	R6.50	9.50	13.10

REEL	Reel Size	Box	Box Size(mm)	Carton	Carton Size(mm)	G.W.(kg)
3000 pcs	7 inch	30,000 pcs	203×203×195	120,000 pcs	438×438×220	