

5 Orderable Information

DEVICE	PACKAGE	OP TEMP	ECO PLAN	MSL	PACKING OPTION	SORT
CJ74ACT245AGN	SOP20	-40~125°C	RoHS & Green	Level 3 168HR	Tape and Reel 2000 Units / Reel	Active
CJ74ACT245BGN	TSSOP20	-40~125°C	RoHS & Green	Level 3 168HR	Tape and Reel 4000 Units / Reel	Active

Note:

ECO PLAN: For the RoHS and Green certification standards of this product, please refer to the official report provided by JSCJ.

MSL: Moisture Sensitivity Level. Determined according to JEDEC industry standard classification.

SORT: Specifically defined as follows:

Active: Recommended for new products;

Customized: Products manufactured to meet the specific needs of customers;

Preview: The device has been released and has not been fully mass produced. The sample may or may not be available;

NoRD: It is not recommended to use the device for new design. The device is only produced for the needs of existing customers;

Obsolete: The device has been discontinued.

6 Pin Configuration and Marking Information

6.1 Pin Configuration

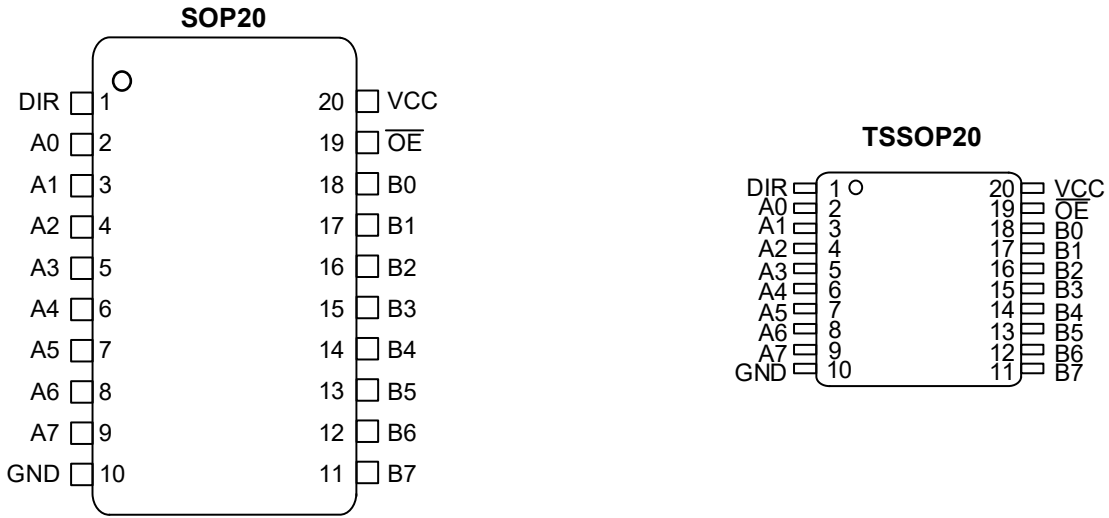
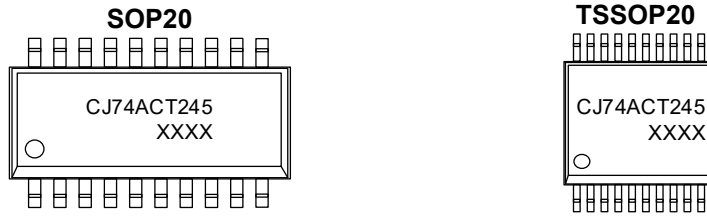

Figure 6-1 Pin configuration

6.2 Pin Function

PIN		I/O ⁽¹⁾	DESCRIPTION
No.	NAME		
1	DIR	-	Direction-control
2	A0	I/O	Data input/output
3	A1	I/O	Data input/output
4	A2	I/O	Data input/output
5	A3	I/O	Data input/output
6	A4	I/O	Data input/output
7	A5	I/O	Data input/output
8	A6	I/O	Data input/output
9	A7	I/O	Data input/output
10	GND	G	Ground (0V)
11	B7	I/O	Data input/output
12	B6	I/O	Data input/output
13	B5	I/O	Data input/output
14	B4	I/O	Data input/output
15	B3	I/O	Data input/output
16	B2	I/O	Data input/output
17	B1	I/O	Data input/output
18	B0	I/O	Data input/output
19	\overline{OE}	I	Output enable input (active LOW)
20	VCC	P	Supply voltage

(1) I-Input, O-Output, P-Power, G-Ground

6.3 Marking Information

XXXX: Code, indicates weekly record information.

7 Specifications

7.1 Absolute Maximum Ratings

Voltages are referenced to GND (ground=0V), unless otherwise specified.

SYMBOL	PARAMETER	CONDITIONS		MIN.	MAX.	UNIT
V_{CC}	Supply voltage	-		-0.5	+7	V
I_{CC}	Continuous supply current	-		-	200	mA
I_{GND}	Continuous ground current	-		-200	-	mA
I_{IK}	Input clamping current	$V_I < 0V$ or $V_I > V_{CC}$		-	± 20	mA
I_{OK}	Output clamping current	$V_O < 0V$ or $V_O > V_{CC}$		-	± 20	mA
I_O	Continuous output current	$V_O = 0$ to V_{CC}		-	± 50	mA
T_{stg}	Storage temperature	-		-65	+150	°C
T_L	Soldering temperature	10s	SOP/TSSOP	-	260	°C

Note: Absolute maximum ratings indicate sustained limits beyond which damage to the device may occur. All voltage parameters are absolute voltages referenced to GND. The thermal resistance and power dissipation ratings are measured under board mounted and still air conditions.

7.2 Recommended Operating Conditions

SYMBOL	PARAMETER	CONDITIONS	MIN.	TYP.	MAX.	UNIT
V_{CC}	Supply voltage	-	4.5	-	5.5	V
V_I	Input voltage	-	0	-	V_{CC}	V
V_O	Output voltage	-	0	-	V_{CC}	V
I_{OH}	High-level output current	-	-	-	-24	mA
I_{OL}	Low-level output current	-	-	-	24	mA
T_{amb}	Ambient temperature	-	-40	-	+125	°C

7.3 Electrical Characteristics

7.3.1 DC Characteristics

$T_{amb} = -40^{\circ}\text{C}$ to $+125^{\circ}\text{C}$, voltages are referenced to GND (ground=0V), unless otherwise specified.

SYMBOL	PARAMETER	CONDITIONS	MIN.	TYP.	MAX.	UNIT
V_{IH}	HIGH-level input voltage	$V_{CC}=4.5$ to 5.5V	2	-	-	V
V_{IL}	LOW-level input voltage	$V_{CC}=4.5$ to 5.5V	-	-	0.8	V
V_{OH}	HIGH-level output voltage	$V_{CC}=4.5\text{V}; I_o=-50\mu\text{A}$	4.4	4.49	-	V
		$V_{CC}=4.5\text{V}; I_o=-24\text{mA}$	3.76	-	-	V
		$V_{CC}=5.5\text{V}; I_o=-50\mu\text{A}$	5.4	-	-	V
		$V_{CC}=5.5\text{V}; I_o=-24\text{mA}$	4.76	-	-	V
		$V_{CC}=5.5\text{V}; I_o=-75\text{mA}$	3.85	-	-	V
V_{OL}	LOW-level output voltage	$V_{CC}=4.5\text{V}; I_o=50\mu\text{A}$	-	0.001	0.1	V
		$V_{CC}=4.5\text{V}; I_o=24\text{mA}$	-	-	0.44	V
		$V_{CC}=5.5\text{V}; I_o=50\mu\text{A}$	-	0.001	0.1	V
		$V_{CC}=5.5\text{V}; I_o=24\text{mA}$	-	-	0.44	V
		$V_{CC}=5.5\text{V}; I_o=75\text{mA}$	-	-	1.65	V
I_I	Input leakage current	$V_{CC}=5.5\text{V}; V_i=V_{CC}$ or GND	-	-	± 20	μA
I_{CC}	Supply current	$V_{CC}=5.5\text{V}; V_i=V_{CC}$ or GND; $I_o=0\text{A}$	-	-	200	μA
ΔI_{CC}	Additional supply current	$V_{CC}=5.5\text{V}$; One input at $V_i=V_{CC}-2.1\text{V}$; Other inputs at V_{CC} or GND; $I_o=0\text{A}$	-	-	1.5	mA

7.3.2 AC Characteristics

$T_{amb} = -40^{\circ}\text{C}$ to $+125^{\circ}\text{C}$, voltages are referenced to GND (ground=0V), unless otherwise specified.

SYMBOL	PARAMETER	CONDITIONS	MIN.	TYP.	MAX.	UNIT
t_{PLH}	A to B to propagation delay	See Figure 8-3 $V_{CC}=5.5\text{V}; C_L=50\text{pF}; R_L=500\Omega$	-	4	7.5	ns
t_{PHL}	A to B to propagation delay	See Figure 8-3 $V_{CC}=5.5\text{V}; C_L=50\text{pF}; R_L=500\Omega$	-	4	8	ns
t_{PZH}	$\overline{\text{OE}}$ to A/B enable time	See Figure 8-3 $V_{CC}=5.5\text{V}; C_L=50\text{pF}; R_L=500\Omega$	-	5	10	ns
t_{PZL}	$\overline{\text{OE}}$ to A/B enable time	See Figure 8-3 $V_{CC}=5.5\text{V}; C_L=50\text{pF}; R_L=500\Omega$	-	5.5	10	ns
t_{PHZ}	$\overline{\text{OE}}$ to A/B enable time	See Figure 8-3 $V_{CC}=5.5\text{V}; C_L=50\text{pF}; R_L=500\Omega$	-	5.5	10	ns
t_{PLZ}	$\overline{\text{OE}}$ to A/B enable time	See Figure 8-3 $V_{CC}=5.5\text{V}; C_L=50\text{pF}; R_L=500\Omega$	-	5	10	ns

8 Detailed Description

8.1 Overview

The CJ74ACT245 are octal bus transceivers with 3-state outputs.

8.2 Functional Block Diagram

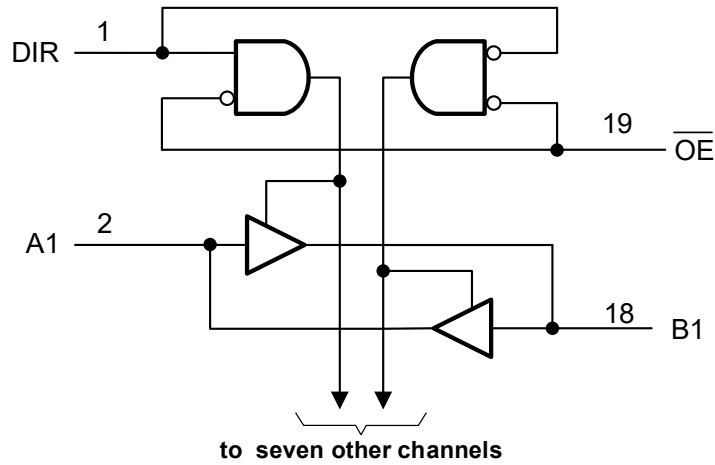

Figure 8-1 Logic symbol

8.3 Function Table

INPUT		OPERATION
$\overline{\text{OE}}$	DIR	
L	L	B data to A bus
L	H	A data to B bus
H	X	Isolation

Note: H=HIGH voltage level; L=LOW voltage level.

8.4 Testing Circuit

8.4.1 AC Testing Circuit

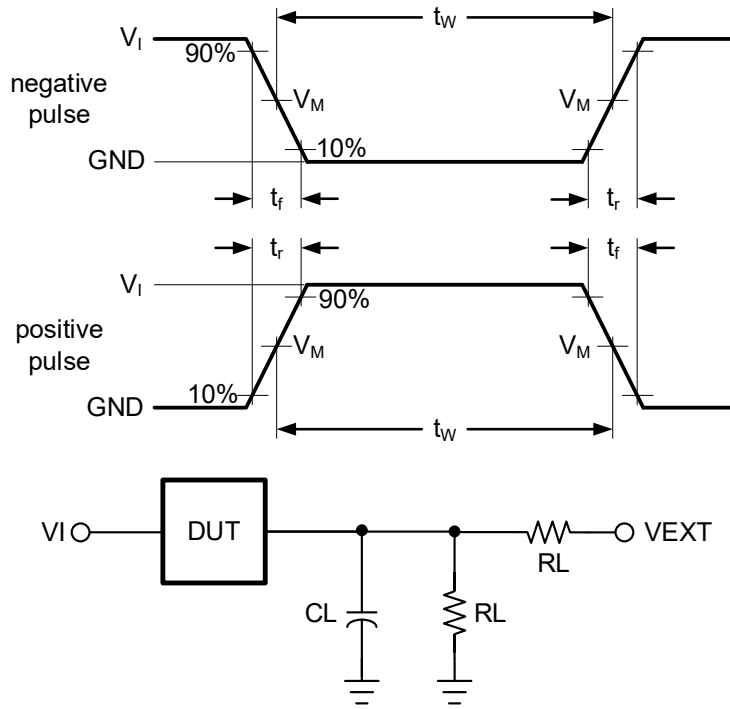

Figure 8-2 Test circuit for measuring switching times

Definitions for test circuit:

CL includes probe and jig capacitance.

8.4.2 AC Testing Waveforms

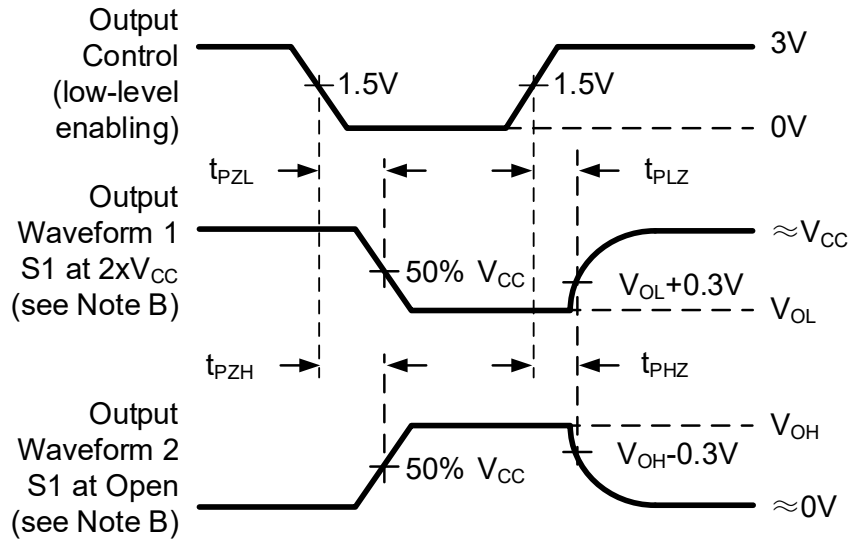

Figure 8-3 The data input (OE) to input/output (A or B) propagation delays

8.4.3 Measurement Points

SUPPLY VOLTAGE	INPUT	OUTPUT
V_{CC}	V_M	V_M
5.5V	$0.5 \times V_{CC}$	$0.5 \times V_{CC}$

8.4.4 Test Data

SUPPLY VOLTAGE	INPUT		LOAD		V_{EXT}
V_{CC}	V_I	$t_r = t_f$	C_L	R_L	t_{PLH}/t_{PHL}
5.5V	V_{CC}	$\leq 2.5ns$	50pF	500Ω	Open

9 Mechanical Information

9.1 SOP20 Mechanical Information

9.1.1 SOP20 Outline Dimensions

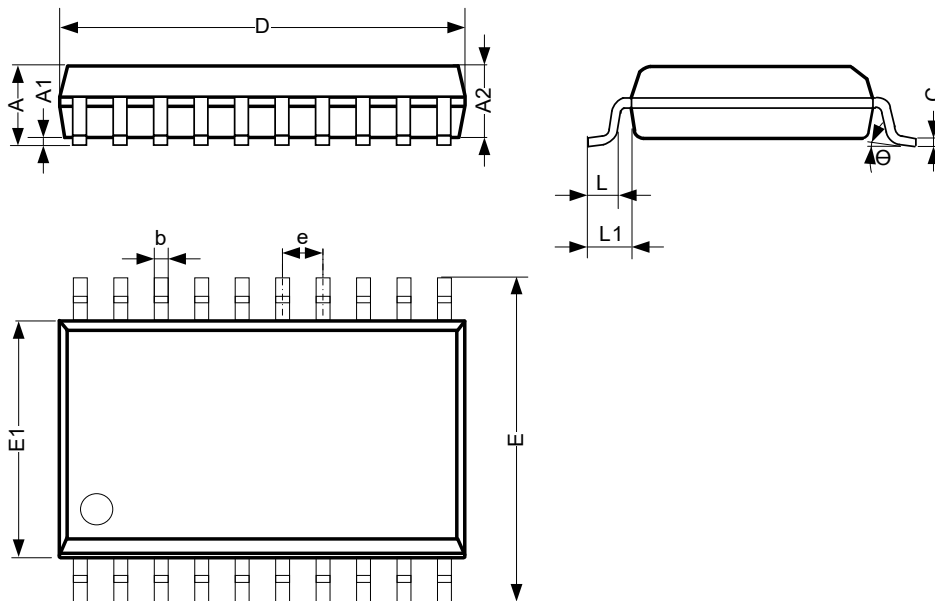

SYMBOL	Dimensions In Millimeters		
	Min.	Typ.	Max.
A	2.47	-	2.65
A1	0.05	-	0.30
A2	2.20	-	2.44
b	0.35	-	0.50
c	0.15	-	0.30
D	12.54	-	12.94
E	10.00	-	10.60
E1	7.30	-	7.70
e	1.27 BSC		
L	0.40	-	1.05
L1	1.30	-	1.50
Θ	0°	-	8°
Unit: mm			

9.2 TSSOP20 Mechanical Information

9.2.1 TSSOP20 Outline Dimensions

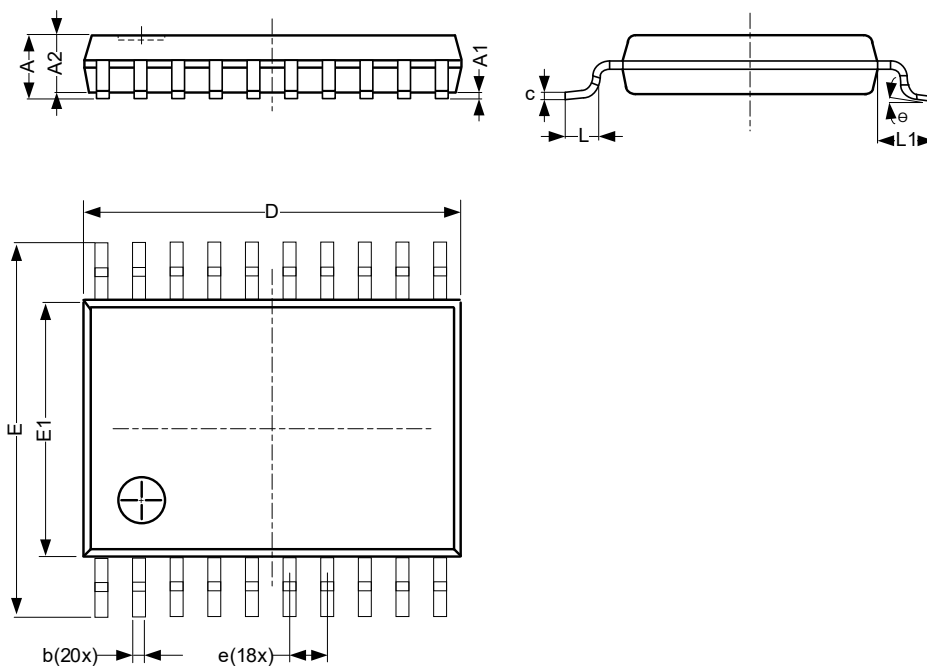

SYMBOL	Dimensions In Millimeters		
	Min.	Typ.	Max.
A	-	-	1.20
A1	0.05	-	0.15
A2	0.80	-	1.05
b	0.19	-	0.30
c	0.09	-	0.20
D	6.40	-	6.60
E	6.20	-	6.60
E1	4.30	-	4.50
e	0.65 BSC		
L	0.45	-	0.75
L1	-	1.00	-
θ	0°	-	8°
Unit: mm			

10 Notes and Revision History

10.1 Associated Product Family and Others

To view other products of the same type or IC products of other types, click the official website of JSCJ -- <https://www.jscj-elec.com> for more details.

10.2 Notes

Electrostatic Discharge Caution



This IC may be damaged by ESD. Relevant personnel shall comply with correct installation and use specifications to avoid ESD damage to the IC. If appropriate measures are not taken to prevent ESD damage, the hazards caused by ESD include but are not limited to degradation of integrated circuit performance or complete damage of integrated circuit. For some precision integrated circuits, a very small parameter change may cause the whole device to be inconsistent with its published specifications.

DISCLAIMER

IMPORTANT NOTICE, PLEASE READ CAREFULLY

The information in this data sheet is intended to describe the operation and characteristics of our products. JSCJ has the right to make any modification, enhancement, improvement, correction or other changes to any content in this data sheet, including but not limited to specification parameters, circuit design and application information, without prior notice.

Any person who purchases or uses JSCJ products for design shall: 1. Select products suitable for circuit application and design; 2. Design, verify and test the rationality of circuit design; 3. Procedures to ensure that the design complies with relevant laws and regulations and the requirements of such laws and regulations. JSCJ makes no warranty or representation as to the accuracy or completeness of the information contained in this data sheet and assumes no responsibility for the application or use of any of the products described in this data sheet.

Without the written consent of JSCJ, this product shall not be used in occasions requiring high quality or high reliability, including but not limited to the following occasions: medical equipment, military facilities and aerospace. JSCJ shall not be responsible for casualties or property losses caused by abnormal use or application of this product.

Official Website: www.jscj-elec.com

Copyright © JIANGSU CHANGJING ELECTRONICS TECHNOLOGY CO., LTD