

Single 2-input NAND Gate

CJ74AHC/AHCT1G00 Logic

1 Introduction

CJ74AHC1G00 and CJ74AHCT1G00 are high-speed Si-gate CMOS devices. They provide a 2-input NAND function.

The AHC device has CMOS input switching levels and supply voltage range 2V to 5.5V.

The AHCT device has TTL input switching levels and supply voltage range 4.5V to 5.5V.

2 Available Packages

PART NUMBER	PACKAGE
CJ74AHC1G00	SOT-23-5L
	SOT-353
CJ74AHCT1G00	SOT-23-5L
	SOT-353

Note: For all available packages, please refer to the part Orderable Information.

3 Features

- Symmetrical output impedance
- Low power dissipation
- Balanced propagation delays
- Specified from -40°C to +125°C

4 Applications

- Enable or disable a digital signal
- Controlling an indicator LED
- Translation between communication modules and system controllers



Logic symbol

5 Orderable Information

DEVICE	PACKAGE	OP TEMP	ECO PLAN	MSL	PACKING OPTION	SORT
CJ74AHC1G00M5N	SOT-23-5L	-40~125°C	RoHS & Green	Level 3 168HR	Tape and Reel 3000 Units / Reel	Active
CJ74AHCT1G00M5N	SOT-23-5L	-40~125°C	RoHS & Green	Level 3 168HR	Tape and Reel 3000 Units / Reel	Active
CJ74AHC1G00R5N	SOT-353	-40~125°C	RoHS & Green	Level 3 168HR	Tape and Reel 3000 Units / Reel	Active
CJ74AHCT1G00R5N	SOT-353	-40~125°C	RoHS & Green	Level 3 168HR	Tape and Reel 3000 Units / Reel	Active

Note:

ECO PLAN: For the RoHS and Green certification standards of this product, please refer to the official report provided by JSCJ.

MSL: Moisture Sensitivity Level. Determined according to JEDEC industry standard classification.

SORT: Specifically defined as follows:

Active: Recommended for new products;

Customized: Products manufactured to meet the specific needs of customers;

Preview: The device has been released and has not been fully mass produced. The sample may or may not be available;

NoRD: It is not recommended to use the device for new design. The device is only produced for the needs of existing customers;

Obsolete: The device has been discontinued.

6 Pin Configuration and Marking Information

6.1 Pin Configuration

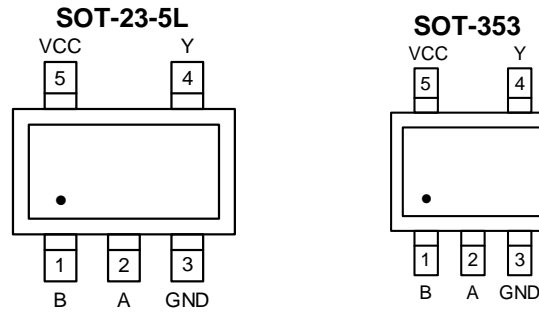

Figure 6-1 Pin configuration

6.2 Pin Function

PIN		I/O ⁽¹⁾	DESCRIPTION
No.	NAME		
1	B	I	Data input
2	A	I	Data input
3	GND	G	Ground (0V)
4	Y	O	Data output
5	VCC	P	Supply voltage

(1) I-Input, O-Output, P-Power, G-Ground

6.3 Marking Information

6.3.1 CJ74AHC1G00

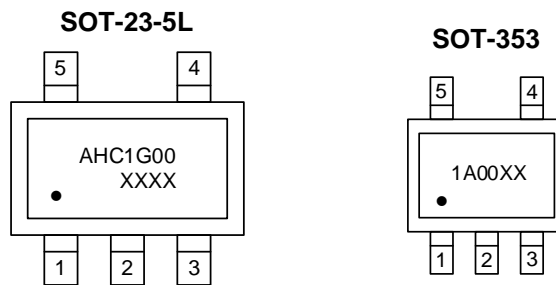

XXXX or XX: Code, indicates weekly record information.

6.3.2 CJ74AHCT1G00

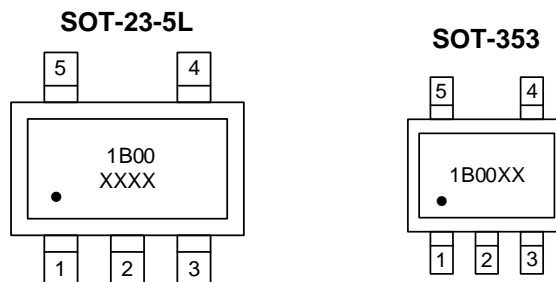

XXXX or XX: Code, indicates weekly record information.

7 Specifications

7.1 Absolute Maximum Ratings

Voltages are referenced to GND (ground=0V), unless otherwise specified.

SYMBOL	PARAMETER	CONDITIONS	MIN.	MAX.	UNIT
V _{CC}	Supply voltage	-	-0.5	+7.0	V
V _I	Input voltage	-	-0.5	+7.0	V
I _{IK}	Input clamping current	V _I <-0.5V	-20	-	mA
I _{OK}	Output clamping current	V _O <-0.5V or V _O >V _{CC} +0.5V ⁽¹⁾	-	±20	mA
I _O	Output current	-0.5V<V _O <V _{CC} +0.5V	-	±25	mA
I _{CC}	Supply current	-	-	75	mA
I _{GND}	Ground current	-	-75	-	mA
T _{stg}	Storage temperature	-	-65	+150	°C
P _{tot}	Total power dissipation	-	-	250	mW
T _L	Soldering temperature	10s	-	260	°C

(1) The input and output voltage ratings may be exceeded if the input and output current ratings are observed.

7.2 Recommended Operating Conditions

Voltages are referenced to GND (ground=0V), unless otherwise specified.

SYMBOL	PARAMETER	CONDITIONS	MIN.	TYP.	MAX.	UNIT
CJ74AHC1G00						
V _{CC}	Supply voltage	-	2.0	5.0	5.5	V
V _I	Input voltage	-	0	-	5.5	V
V _O	Output voltage	-	0	-	V _{CC}	V
T _{amb}	Ambient temperature	-	-40	-	+125	°C
Δt/ΔV	input transition rise and fall rate	V _{CC} =3.3V±0.3V	-	-	100	ns/V
		V _{CC} =5.0V±0.5V	-	-	20	ns/V
CJ74AHCT1G00						
V _{CC}	Supply voltage	-	4.5	5.0	5.5	V
V _I	Input voltage	-	0	-	5.5	V
V _O	Output voltage	-	0	-	V _{CC}	V
T _{amb}	Ambient temperature	-	-40	-	+125	°C
Δt/ΔV	input transition rise and fall rate	V _{CC} =3.3V±0.3V	-	-	-	ns/V
		V _{CC} =5.0V±0.5V	-	-	20	ns/V

7.3 Electrical Characteristics
7.3.1 DC Characteristics 1
 $T_{amb}=25^{\circ}\text{C}$, voltages are referenced to GND (ground=0V), unless otherwise specified.

SYMBOL	PARAMETER	CONDITIONS	MIN.	TYP.	MAX.	UNIT	
CJ74AHC1G00							
V_{IH}	HIGH-level input voltage	$V_{CC}=2.0\text{V}$	1.5	-	-	V	
		$V_{CC}=3.0\text{V}$	2.1	-	-	V	
		$V_{CC}=5.5\text{V}$	3.85	-	-	V	
V_{IL}	LOW-level input voltage	$V_{CC}=2.0\text{V}$	-	-	0.5	V	
		$V_{CC}=3.0\text{V}$	-	-	0.9	V	
		$V_{CC}=5.5\text{V}$	-	-	1.65	V	
V_{OH}	HIGH-level output voltage	$V_I = V_{IH} \text{ or } V_{IL}$	$I_O=-50\mu\text{A}; V_{CC}=2.0\text{V}$	1.9	2.0	-	V
			$I_O=-50\mu\text{A}; V_{CC}=3.0\text{V}$	2.9	3.0	-	V
			$I_O=-50\mu\text{A}; V_{CC}=4.5\text{V}$	4.4	4.5	-	V
			$I_O=-4\text{mA}; V_{CC}=3.0\text{V}$	2.58	-	-	V
			$I_O=-8\text{mA}; V_{CC}=4.5\text{V}$	3.94	-	-	V
V_{OL}	LOW-level output voltage	$V_I = V_{IH} \text{ or } V_{IL}$	$I_O=50\mu\text{A}; V_{CC}=2.0\text{V}$	-	0	0.1	V
			$I_O=50\mu\text{A}; V_{CC}=3.0\text{V}$	-	0	0.1	V
			$I_O=50\mu\text{A}; V_{CC}=4.5\text{V}$	-	0	0.1	V
			$I_O=4\text{mA}; V_{CC}=3.0\text{V}$	-	-	0.36	V
			$I_O=8\text{mA}; V_{CC}=4.5\text{V}$	-	-	0.36	V
I_I	Input leakage current	$V_I=5.5\text{V}$ or GND; $V_{CC}=0\text{V}$ to 5.5V	-	-	1.0	μA	
I_{CC}	Supply current	$V_I=V_{CC}$ or GND; $I_O=0\text{A}; V_{CC}=5.5\text{V}$	-	-	1.0	μA	
C_I	Input capacitance	-	-	1.5	10	pF	
CJ74AHCT1G00							
V_{IH}	HIGH-level input voltage	$V_{CC}=4.5\text{V}$ to 5.5V	2.0	-	-	V	
V_{IL}	LOW-level input voltage	$V_{CC}=4.5\text{V}$ to 5.5V	-	-	0.8	V	
V_{OH}	HIGH-level output voltage	$V_I = V_{IH} \text{ or } V_{IL}$	$I_O=-50\mu\text{A}; V_{CC}=4.5\text{V}$	4.4	4.5	-	V
			$I_O=-8\text{mA}; V_{CC}=4.5\text{V}$	3.94	-	-	V
V_{OL}	LOW-level output voltage	$V_I = V_{IH} \text{ or } V_{IL}$	$I_O=50\mu\text{A}; V_{CC}=4.5\text{V}$	-	0	0.1	V
			$I_O=8\text{mA}; V_{CC}=4.5\text{V}$	-	-	0.36	V
I_I	Input leakage current	$V_I=5.5\text{V}$ or GND; $V_{CC}=0\text{V}$ to 5.5V	-	-	1.0	μA	
I_{CC}	Supply current	$V_I=V_{CC}$ or GND; $I_O=0\text{A}; V_{CC}=5.5\text{V}$	-	-	1.0	μA	
ΔI_{CC}	Additional supply current	Per input pin; $V_I=3.4\text{V}$; Other inputs at V_{CC} or GND; $I_O=0\text{A}; V_{CC}=5.5\text{V}$	-	-	1.35	mA	
C_I	Input capacitance	-	-	1.5	10	pF	

7.3.2 DC Characteristics 2

 T_{amb}=-40°C to +85°C, voltages are referenced to GND (ground=0V), unless otherwise specified.

SYMBOL	PARAMETER	CONDITIONS	MIN.	TYP.	MAX.	UNIT	
CJ74AHC1G00							
V _{IH}	HIGH-level input voltage	V _{CC} =2.0V	1.5	-	-	V	
		V _{CC} =3.0V	2.1	-	-	V	
		V _{CC} =5.5V	3.85	-	-	V	
V _{IL}	LOW-level input voltage	V _{CC} =2.0V	-	-	0.5	V	
		V _{CC} =3.0V	-	-	0.9	V	
		V _{CC} =5.5V	-	-	1.65	V	
V _{OH}	HIGH-level output voltage	V _I = V _{IH} or V _{IL}	I _O =-50uA; V _{CC} =2.0V	1.9	-	-	V
			I _O =-50uA; V _{CC} =3.0V	2.9	-	-	V
			I _O =-50uA; V _{CC} =4.5V	4.4	-	-	V
			I _O =-4mA; V _{CC} =3.0V	2.48	-	-	V
			I _O =-8mA; V _{CC} =4.5V	3.8	-	-	V
V _{OL}	LOW-level output voltage	V _I = V _{IH} or V _{IL}	I _O =50uA; V _{CC} =2.0V	-	-	0.1	V
			I _O =50uA; V _{CC} =3.0V	-	-	0.1	V
			I _O =50uA; V _{CC} =4.5V	-	-	0.1	V
			I _O =4mA; V _{CC} =3.0V	-	-	0.44	V
			I _O =8mA; V _{CC} =4.5V	-	-	0.44	V
I _I	Input leakage current	V _I =5.5V or GND; V _{CC} =0V to 5.5V	-	-	1.0	uA	
I _{CC}	Supply current	V _I =V _{CC} or GND; I _O =0A; V _{CC} =5.5V	-	-	10	uA	
C _I	Input capacitance	-	-	-	10	pF	
CJ74AHCT1G00							
V _{IH}	HIGH-level input voltage	V _{CC} =4.5V to 5.5V	2.0	-	-	V	
V _{IL}	LOW-level input voltage	V _{CC} =4.5V to 5.5V	-	-	0.8	V	
V _{OH}	HIGH-level output voltage	V _I = V _{IH} or V _{IL}	I _O =-50uA; V _{CC} =4.5V	4.4	-	-	V
			I _O =-8mA; V _{CC} =4.5V	3.8	-	-	V
V _{OL}	LOW-level output voltage	V _I = V _{IH} or V _{IL}	I _O =50uA; V _{CC} =4.5V	-	-	0.1	V
			I _O =8mA; V _{CC} =4.5V	-	-	0.44	V
I _I	Input leakage current	V _I =5.5V or GND; V _{CC} =0V to 5.5V	-	-	1.0	uA	
I _{CC}	Supply current	V _I =V _{CC} or GND; I _O =0A; V _{CC} =5.5V	-	-	10	uA	
ΔI _{CC}	Additional supply current	Per input pin; V _I =3.4V; Other inputs at V _{CC} or GND; I _O =0A; V _{CC} =5.5V	-	-	1.5	mA	
C _I	Input capacitance	-	-	-	10	pF	

7.3.3 DC Characteristics 3
 $T_{amb} = -40^{\circ}\text{C}$ to $+125^{\circ}\text{C}$, voltages are referenced to GND (ground=0V), unless otherwise specified.

SYMBOL	PARAMETER	CONDITIONS	MIN.	TYP.	MAX.	UNIT	
CJ74AHC1G00							
V_{IH}	HIGH-level input voltage	$V_{CC}=2.0\text{V}$	1.5	-	-	V	
		$V_{CC}=3.0\text{V}$	2.1	-	-	V	
		$V_{CC}=5.5\text{V}$	3.85	-	-	V	
V_{IL}	LOW-level input voltage	$V_{CC}=2.0\text{V}$	-	-	0.5	V	
		$V_{CC}=3.0\text{V}$	-	-	0.9	V	
		$V_{CC}=5.5\text{V}$	-	-	1.65	V	
V_{OH}	HIGH-level output voltage	$V_I = V_{IH}$ or V_{IL}	$I_O=-50\mu\text{A}; V_{CC}=2.0\text{V}$	1.9	-	-	V
			$I_O=-50\mu\text{A}; V_{CC}=3.0\text{V}$	2.9	-	-	V
			$I_O=-50\mu\text{A}; V_{CC}=4.5\text{V}$	4.4	-	-	V
			$I_O=-4\text{mA}; V_{CC}=3.0\text{V}$	2.4	-	-	V
			$I_O=-8\text{mA}; V_{CC}=4.5\text{V}$	3.7	-	-	V
V_{OL}	LOW-level output voltage	$V_I = V_{IH}$ or V_{IL}	$I_O=50\mu\text{A}; V_{CC}=2.0\text{V}$	-	-	0.1	V
			$I_O=50\mu\text{A}; V_{CC}=3.0\text{V}$	-	-	0.1	V
			$I_O=50\mu\text{A}; V_{CC}=4.5\text{V}$	-	-	0.1	V
			$I_O=4\text{mA}; V_{CC}=3.0\text{V}$	-	-	0.55	V
			$I_O=8\text{mA}; V_{CC}=4.5\text{V}$	-	-	0.55	V
I_I	Input leakage current	$V_I=5.5\text{V}$ or GND; $V_{CC}=0\text{V}$ to 5.5V	-	-	2.0	μA	
I_{CC}	Supply current	$V_I=V_{CC}$ or GND; $I_O=0\text{A}; V_{CC}=5.5\text{V}$	-	-	40	μA	
C_I	Input capacitance	-	-	-	10	pF	
CJ74AHCT1G00							
V_{IH}	HIGH-level input voltage	$V_{CC}=4.5\text{V}$ to 5.5V	2.0	-	-	V	
V_{IL}	LOW-level input voltage	$V_{CC}=4.5\text{V}$ to 5.5V	-	-	0.8	V	
V_{OH}	HIGH-level output voltage	$V_I = V_{IH}$ or V_{IL}	$I_O=-50\mu\text{A}; V_{CC}=4.5\text{V}$	4.4	-	-	V
			$I_O=-8\text{mA}; V_{CC}=4.5\text{V}$	3.7	-	-	V
V_{OL}	LOW-level output voltage	$V_I = V_{IH}$ or V_{IL}	$I_O=50\mu\text{A}; V_{CC}=4.5\text{V}$	-	-	0.1	V
			$I_O=8\text{mA}; V_{CC}=4.5\text{V}$	-	-	0.55	V
I_I	Input leakage current	$V_I=5.5\text{V}$ or GND; $V_{CC}=0\text{V}$ to 5.5V	-	-	2.0	μA	
I_{CC}	Supply current	$V_I=V_{CC}$ or GND; $I_O=0\text{A}; V_{CC}=5.5\text{V}$	-	-	40	μA	
ΔI_{CC}	Additional supply current	Per input pin; $V_I=3.4\text{V}$; Other inputs at V_{CC} or GND; $I_O=0\text{A}; V_{CC}=5.5\text{V}$	-	-	1.5	mA	
C_I	Input capacitance	-	-	-	10	pF	

7.3.4 AC Characteristics 1

 T_{amb}=25°C, GND=0V, t_r=t_f≤3.0ns, unless otherwise specified.

SYMBOL	PARAMETER	CONDITIONS	MIN.	TYP.	MAX.	UNIT	
CJ74AHC1G00							
t _{pd}	Propagation delay	A and B to Y See Figure 8-5 ⁽¹⁾	C _L =15pF; V _{CC} =3.0V to 3.6V ⁽²⁾	-	4.5	7.9	ns
			C _L =50pF; V _{CC} =3.0V to 3.6V ⁽²⁾	-	6.5	11.4	ns
			C _L =15pF; V _{CC} =4.5V to 5.5V ⁽³⁾	-	3.5	5.5	ns
			C _L =50pF; V _{CC} =4.5V to 5.5V ⁽³⁾	-	4.9	7.5	ns
C _{PD}	Power dissipation capacitance	Per buffer; C _L =50pF; f=1MHz; V _I = GND to V _{CC} ⁽⁴⁾	-	17	-	pF	
CJ74AHCT1G00							
t _{pd}	Propagation delay	A and B to Y See Figure 8-5 ⁽¹⁾	C _L =15pF; V _{CC} =4.5V to 5.5V ⁽³⁾	-	3.6	6.2	ns
			C _L =50pF; V _{CC} =4.5V to 5.5V ⁽³⁾	-	5.0	7.9	ns
C _{PD}	Power dissipation capacitance	Per buffer; V _I = GND to V _{CC} ⁽⁴⁾	-	18	-	pF	

- (1) t_{pd} is the same as t_{PLH} and t_{PHL}.
- (2) Typical values are measured at V_{CC}=3.3V.
- (3) Typical values are measured at V_{CC}=5V.
- (4) C_{PD} is used to determine the dynamic power dissipation (P_D in μW).

$$P_D = C_{PD} \times V_{CC}^2 \times f_i + \sum (C_L \times V_{CC}^2 \times f_o)$$
 where:

 f_i=input frequency in MHz;

 f_o=output frequency in MHz;

 C_L=output load capacitance in pF;

 V_{CC}=supply voltage in Volts.

7.3.5 AC Characteristics 2
 $T_{amb} = -40^{\circ}\text{C}$ to $+85^{\circ}\text{C}$, $GND = 0V$, $t_r = t_f \leq 3.0\text{ns}$, unless otherwise specified.

SYMBOL	PARAMETER	CONDITIONS	MIN.	TYP.	MAX.	UNIT	
CJ74AHC1G00							
t_{pd}	Propagation delay	A and B to Y See Figure 8-5 ⁽¹⁾	$C_L = 15\text{pF};$ $V_{CC} = 3.0V$ to $3.6V^{(2)}$	1.0	-	9.5	ns
			$C_L = 50\text{pF};$ $V_{CC} = 3.0V$ to $3.6V^{(2)}$	1.0	-	13.0	ns
			$C_L = 15\text{pF};$ $V_{CC} = 4.5V$ to $5.5V^{(3)}$	1.0	-	6.5	ns
			$C_L = 50\text{pF};$ $V_{CC} = 4.5V$ to $5.5V^{(3)}$	1.0	-	8.5	ns
CJ74AHCT1G00							
t_{pd}	Propagation delay	A and B to Y See Figure 8-5 ⁽¹⁾	$C_L = 15\text{pF};$ $V_{CC} = 4.5V$ to $5.5V^{(3)}$	1.0	-	7.1	ns
			$C_L = 50\text{pF};$ $V_{CC} = 4.5V$ to $5.5V^{(3)}$	1.0	-	9.0	ns

(1) t_{pd} is the same as t_{PLH} and t_{PHL} .

(2) Typical values are measured at $V_{CC} = 3.3V$.

(3) Typical values are measured at $V_{CC} = 5V$.

7.3.6 AC Characteristics 3
 $T_{amb} = -40^{\circ}\text{C}$ to $+125^{\circ}\text{C}$, $GND = 0V$, $t_r = t_f \leq 3.0\text{ns}$, unless otherwise specified.

SYMBOL	PARAMETER	CONDITIONS	MIN.	TYP.	MAX.	UNIT	
CJ74AHC1G00							
t_{pd}	Propagation delay	A and B to Y See Figure 8-5 ⁽¹⁾	$C_L = 15\text{pF};$ $V_{CC} = 3.0V$ to $3.6V^{(2)}$	1.0	-	10.5	ns
			$C_L = 50\text{pF};$ $V_{CC} = 3.0V$ to $3.6V^{(2)}$	1.0	-	14.5	ns
			$C_L = 15\text{pF};$ $V_{CC} = 4.5V$ to $5.5V^{(3)}$	1.0	-	7.0	ns
			$C_L = 50\text{pF};$ $V_{CC} = 4.5V$ to $5.5V^{(3)}$	1.0	-	9.5	ns
CJ74AHCT1G00							
t_{pd}	Propagation delay	A and B to Y See Figure 8-5 ⁽¹⁾	$C_L = 15\text{pF};$ $V_{CC} = 4.5V$ to $5.5V^{(3)}$	1.0	-	8.0	ns
			$C_L = 50\text{pF};$ $V_{CC} = 4.5V$ to $5.5V^{(3)}$	1.0	-	10.0	ns

(1) t_{pd} is the same as t_{PLH} and t_{PHL} .

(2) Typical values are measured at $V_{CC} = 3.3V$.

(3) Typical values are measured at $V_{CC} = 5V$.

8 Detailed Description

8.1 Overview

CJ74AHC1G00 and CJ74AHCT1G00 are high-speed Si-gate CMOS devices. They provide a 2-input NAND function.

The AHC device has CMOS input switching levels and supply voltage range 2V to 5.5V.

The AHCT device has TTL input switching levels and supply voltage range 4.5V to 5.5V.

8.2 Functional Block Diagram

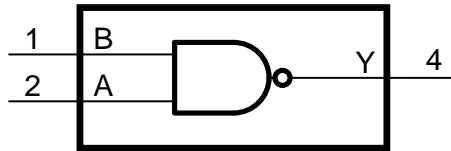

Figure 8-1 Logic symbol



Figure 8-2 IEC logic symbol

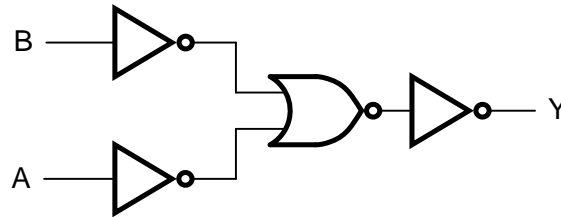

Figure 8-3 Logic diagram

8.3 Function Table

INPUT		OUTPUT
A	B	Y
L	L	H
L	H	H
H	L	H
H	H	L

Note: H=HIGH voltage level; L=LOW voltage level.

8.4 Testing Circuit

8.4.1 AC Testing Circuit

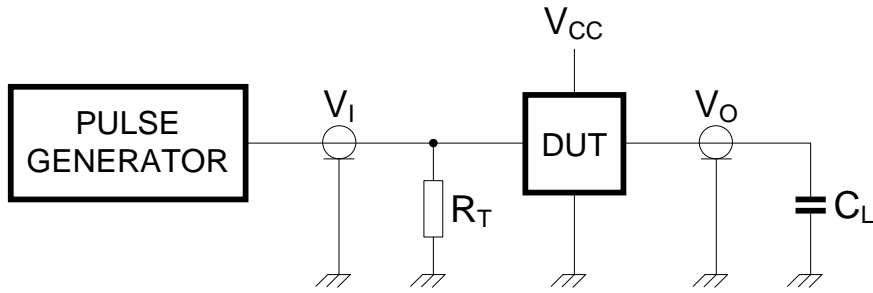

Figure 8-4 Test circuit for measuring switching times

Definitions for test circuit:

C_L =Load capacitance including jig and probe capacitance.

R_T =Termination resistance should be equal to output impedance Z_o of the pulse generator.

8.4.2 AC Testing Waveforms

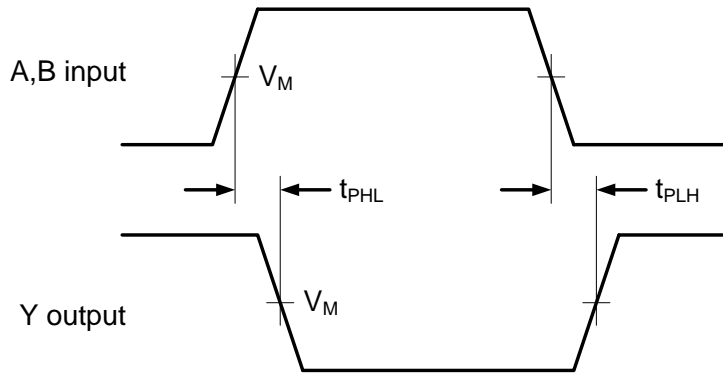

Figure 8-5 The inputs (A and B) to output (Y) propagation delays

8.4.3 Measurement Points

TYPE	INPUT		OUTPUT
	V_I	V_M	V_M
CJ74AHC1G00	GND to V_{CC}	$0.5 \times V_{CC}$	$0.5 \times V_{CC}$
CJ74AHCT1G00	GND to 3.0V	1.5V	$0.5 \times V_{CC}$

9 Mechanical Information

9.1 SOT-23-5L Mechanical Information

9.1.1 SOT-23-5L Outline Dimensions

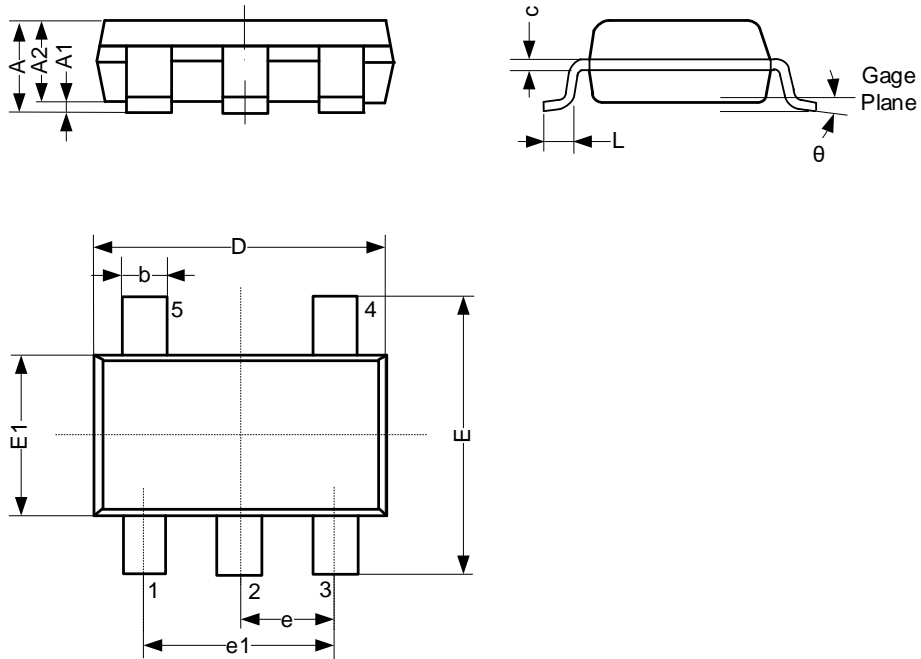

SYMBOL	Dimensions In Millimeters		
	Min.	Typ.	Max.
A	-	-	1.26
A1	0.00	-	0.12
A2	1.00	-	1.20
b	0.30	-	0.50
c	0.10	-	0.20
D	2.82	-	3.02
E	2.60	-	3.00
E1	1.50	-	1.70
e	0.95 BSC		
e1	1.80	-	2.00
L	0.30	-	0.60
θ	0°	-	8°
Unit: mm			

9.2 SOT-353 Mechanical Information

9.2.1 SOT-353 Outline Dimensions

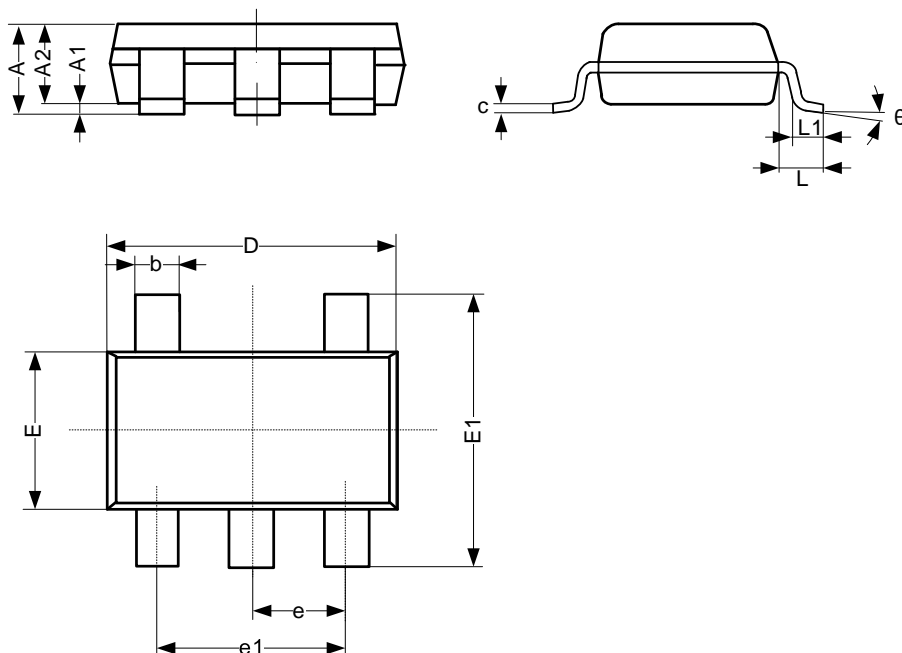

SYMBOL	Dimensions In Millimeters		
	Min.	Typ.	Max.
A	0.90	-	1.10
A1	0.00	-	0.10
A2	0.90	-	1.00
b	0.15	-	0.35
c	0.11	-	0.175
D	2.00	-	2.20
E	1.15	-	1.35
E1	2.15	-	2.45
e	0.65 BSC		
e1	1.20	-	1.40
L	-	0.525	-
L1	0.26	-	0.46
θ	0°	-	8°
Unit: mm			

10 Notes and Revision History

10.1 Associated Product Family and Others

To view other products of the same type or IC products of other types, click the official website of JSCJ -- <https://www.jscj-elec.com> for more details.

10.2 Notes

Electrostatic Discharge Caution



This IC may be damaged by ESD. Relevant personnel shall comply with correct installation and use specifications to avoid ESD damage to the IC. If appropriate measures are not taken to prevent ESD damage, the hazards caused by ESD include but are not limited to degradation of integrated circuit performance or complete damage of integrated circuit. For some precision integrated circuits, a very small parameter change may cause the whole device to be inconsistent with its published specifications.

DISCLAIMER

IMPORTANT NOTICE, PLEASE READ CAREFULLY

The information in this data sheet is intended to describe the operation and characteristics of our products. JSCJ has the right to make any modification, enhancement, improvement, correction or other changes to any content in this data sheet, including but not limited to specification parameters, circuit design and application information, without prior notice.

Any person who purchases or uses JSCJ products for design shall: 1. Select products suitable for circuit application and design; 2. Design, verify and test the rationality of circuit design; 3. Procedures to ensure that the design complies with relevant laws and regulations and the requirements of such laws and regulations. JSCJ makes no warranty or representation as to the accuracy or completeness of the information contained in this data sheet and assumes no responsibility for the application or use of any of the products described in this data sheet.

Without the written consent of JSCJ, this product shall not be used in occasions requiring high quality or high reliability, including but not limited to the following occasions: medical equipment, military facilities and aerospace. JSCJ shall not be responsible for casualties or property losses caused by abnormal use or application of this product.

Official Website: www.jscj-elec.com

Copyright © JIANGSU CHANGJING ELECTRONICS TECHNOLOGY CO., LTD