

2-bit Dual Supply Translating Transceiver:3-state

CJ74AVC2T45 Logic

1 Introduction

The CJ74AVC2T45 is a dual-bit, dual-supply transceiver that enables bidirectional level translation. It features two data input-output ports (nA and nB), a direction control input (DIR) and dual-supply pins ($V_{CC(A)}$ and $V_{CC(B)}$). Both $V_{CC(A)}$ and $V_{CC(B)}$ can be supplied at any voltage between 0.8V and 3.6V making the device suitable for translating between any of the low voltage nodes (0.8V, 1.2V, 1.5V, 1.8V, 2.5V and 3.3V). Pins nA and DIR are referenced to $V_{CC(A)}$ and pins nB are referenced to $V_{CC(B)}$. A HIGH on DIR allows transmission from nA to nB and a LOW on DIR allows transmission from nB to nA.

The device is fully specified for partial power-down applications using I_{OFF} . The I_{OFF} circuitry disables the output, preventing any damaging backflow current through the device when it is powered down. In Suspend mode when either $V_{CC(A)}$ or $V_{CC(B)}$ are at GND level, both A and B are in the high-impedance OFF-state.

2 Available Packages

PART NUMBER	PACKAGE
CJ74AVC2T45	TSSOP8
	VSSOP8

Note: For all available packages, please refer to the part Orderable Information.

3 Features

- Wide supply voltage range:
 - $V_{CC(A)}$: 0.8V to 3.6V
 - $V_{CC(B)}$: 0.8V to 3.6V
- Maximum data rates:
 - 500Mbit/s (1.8V to 3.3V translation)
 - 320Mbit/s (<1.8V to 3.3V translation)
 - 320Mbit/s (translate to 2.5V or 1.8V)
 - 280Mbit/s (translate to 1.5V)
 - 240Mbit/s (translate to 1.2V)
- Suspend mode
- Inputs accept voltages up to 3.6V
- I_{OFF} circuitry provides partial Power-down mode operation
- Specified from -40°C to +125°C

4 Applications

- Smartphones
- Servers
- Desktop PCs and notebooks
- Other portable devices

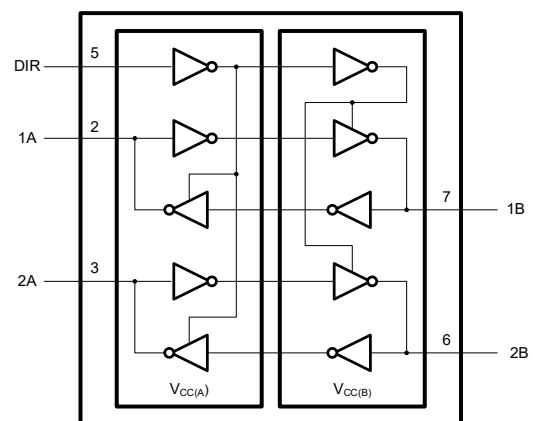

Logic symbol

5 Orderable Information

DEVICE	PACKAGE	OP TEMP	ECO PLAN	MSL	PACKING OPTION	SORT
CJ74AVC2T45BAN	TSSOP8	-40~125°C	RoHS & Green	Level 3 168HR	Tape and Reel 3000 Units / Reel	Active
CJ74 AVC2T45VAN	VSSOP8	-40~125°C	RoHS & Green	Level 3 168HR	Tape and Reel 3000 Units / Reel	Active

Note:

ECO PLAN: For the RoHS and Green certification standards of this product, please refer to the official report provided by JSCJ.

MSL: Moisture Sensitivity Level. Determined according to JEDEC industry standard classification.

SORT: Specifically defined as follows:

Active: Recommended for new products;

Customized: Products manufactured to meet the specific needs of customers;

Preview: The device has been released and has not been fully mass produced. The sample may or may not be available;

NoRD: It is not recommended to use the device for new design. The device is only produced for the needs of existing customers;

Obsolete: The device has been discontinued.

6 Pin Configuration and Marking Information

6.1 Pin Configuration

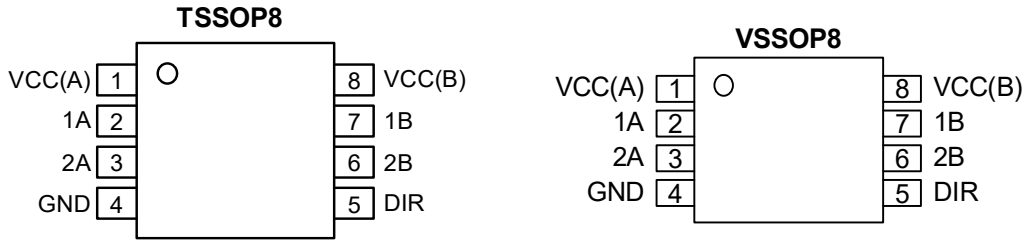

Figure 6-1 Pin configuration

6.2 Pin Function

PIN		I/O ⁽¹⁾	DESCRIPTION
No.	NAME		
1	VCC(A)	P	Supply voltage A (referenced to pins 1A, 2A and DIR)
2	1A	I/O	Data input or output
3	2A	I/O	Data input or output
4	GND	G	Ground (0V)
5	DIR	-	Direction control
6	2B	I/O	Data input or output
7	1B	I/O	Data input or output
8	VCC(B)	P	Supply voltage B (referenced to pins 1B and 2B)

(1) I-Input, O-Output, P-Power, G-Ground

6.3 Marking Information

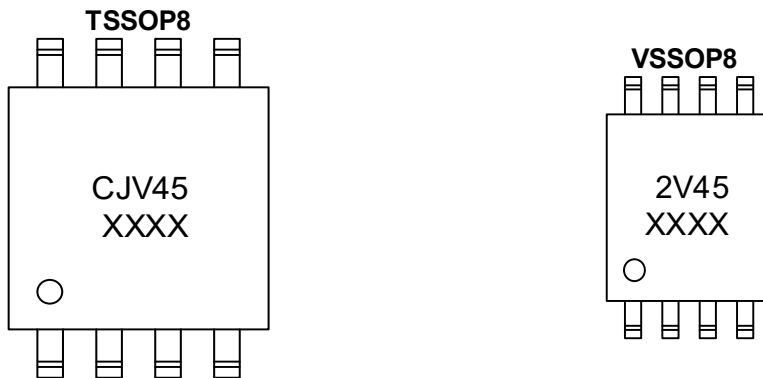

XXXX: Code, indicates weekly record information.

7 Specifications

7.1 Absolute Maximum Ratings

Voltages are referenced to GND (ground=0V), unless otherwise specified.

SYMBOL	PARAMETER	CONDITIONS	MIN.	MAX.	UNIT
$V_{CC(A)}$	Supply Voltage A	-	-0.5	+4.6	V
$V_{CC(B)}$	Supply Voltage B	-	-0.5	+4.6	V
I_{IK}	Input clamping current	$V_I < 0V$	-50	-	mA
V_I	Input Voltage	-(¹)	-0.5	+4.6	V
I_{OK}	Output clamping current	$V_O < 0V$	-50	-	mA
V_O	Output voltage	Active mode(¹)(²)(³)	-0.5	$V_{CCO}+0.5$	V
		Suspend or 3-state mode(¹)	-0.5	+4.6	V
I_O	Output current	$V_O=0V$ to V_{CCO}	-	± 50	mA
I_{CC}	Supply current	$I_{CC(A)}$ or $I_{CC(B)}$	-	100	mA
I_{GND}	Ground current	-	-100	-	mA
T_{stg}	Storage Temperature	-	-65	+150	°C
P_{tot}	Total power dissipation	-	-	250	mW
T_L	Soldering Temperature	10s	-	260	°C

(1) The minimum input voltage rating and output voltage ratings may be exceeded if the input and output current ratings are observed.

(2) V_{CCO} is the supply voltage associated with the output port.

(3) $V_{CCO}+0.5V$ should not exceed 4.6V.

7.2 Recommended Operating Conditions

SYMBOL	PARAMETER	CONDITIONS	MIN.	TYP.	MAX.	UNIT
$V_{CC(A)}$	Supply voltage A	-	0.8	-	3.6	V
$V_{CC(B)}$	Supply voltage B	-	0.8	-	3.6	V
V_I	Input voltage	-	0	-	3.6	V
V_O	Output voltage	Active mode(¹)	0	-	V_{CCO}	V
		Suspend or 3-state mode	0	-	3.6	V
T_{amb}	Ambient temperature	-	-40	-	+125	°C
$\Delta t/\Delta V$	Input transition rise and fall rate	$V_{CCI}=0.8V$ to $3.6V$ (²)	-	-	5	ns/V

(1) V_{CCO} is the supply voltage associated with the output port.

(2) V_{CCI} is the supply voltage associated with the input port.

7.3 ESD Ratings

SYMBOL	ESD RATINGS		VALUE	UNIT
$V_{ESD-HBM}$	Electrostatic discharge	Human body model (HBM)(¹)	± 2000	V

(1) JEDEC document JEP155 states that 500-V HBM allows safe manufacturing with a standard ESD control process.

7.4 Electrical Characteristics

7.4.1 DC Characteristics 1

T_{amb}=25°C, voltages are referenced to GND (ground=0V), unless otherwise specified.

SYMBOL	PARAMETER	CONDITIONS	MIN.	TYP.	MAX.	UNIT
V _{OH}	HIGH-level output voltage	V _I =V _{IH} or V _{IL} ; I _O =-1.5mA; V _{CC(A)} =V _{CC(B)} =0.8V	-	0.69	-	V
V _{OL}	LOW-level output voltage	V _I =V _{IH} or V _{IL} ; I _O =1.5mA; V _{CC(A)} =V _{CC(B)} =0.8V	-	0.07	-	V
I _I	Input leakage current	DIR input; V _I =0V or 3.6V; V _{CC(A)} =V _{CC(B)} =0.8V to 3.6V	-	-	±1	uA
I _{OZ}	OFF-state output current	A or B port; V _O =0V or V _{CCO} ; V _{CC(A)} =V _{CC(B)} =0.8V to 3.6V ⁽¹⁾⁽²⁾	-	-	±2.5	uA
I _{OFF}	Power-off current leakage	A port; V _I or V _O =0V to 3.6V; V _{CC(A)} =0V; V _{CC(B)} =0.8V to 3.6V	-	-	±1	uA
		B port; V _I or V _O =0V to 3.6V; V _{CC(B)} =0V; V _{CC(A)} =0.8V to 3.6V	-	-	±1	uA
C _I	Input capacitance	DIR input; V _I =0V or 3.3V; V _{CC(A)} =V _{CC(B)} =3.3V	-	1.0	-	pF
C _{I/O}	Input/output capacitance	A and B port; Suspend mode; V _O =V _{CCO} or GND; V _{CC(A)} =V _{CC(B)} =3.3V ⁽²⁾	-	4.0	-	pF

(1) For I/O ports, the parameter I_{OZ} includes the input leakage current.

(2) V_{CCO} is the supply voltage associated with the output port.

7.4.2 DC Characteristics 2

T_{amb}=-40°C to +85°C, voltages are referenced to GND (ground=0V), unless otherwise specified.

SYMBOL	PARAMETER	CONDITIONS	MIN.	TYP.	MAX.	UNIT	
V _{IH}	HIGH-level input voltage	Data input ⁽¹⁾	V _{CCI} =0.8V	0.70V _{CCI}	-	-	V
			V _{CCI} =1.1V to 1.95V	0.65V _{CCI}	-	-	V
			V _{CCI} =2.3V to 2.7V	1.6	-	-	V
			V _{CCI} =3.0V to 3.6V	2	-	-	V
		DIR input	V _{CC(A)} =0.8V	0.70V _{CC(A)}	-	-	V
			V _{CC(A)} =1.1V to 1.95V	0.65V _{CC(A)}	-	-	V
			V _{CC(A)} =2.3V to 2.7V	1.6	-	-	V
			V _{CC(A)} =3.0V to 3.6V	2	-	-	V
V _{IL}	LOW-level input voltage	Data input ⁽¹⁾	V _{CCI} =0.8V	-	-	0.30V _{CCI}	V
			V _{CCI} =1.1V to 1.95V	-	-	0.35V _{CCI}	V
			V _{CCI} =2.3V to 2.7V	-	-	0.7	V
			V _{CCI} =3.0V to 3.6V	-	-	0.9	V
		DIR input	V _{CC(A)} =0.8V	-	-	0.30V _{CC(A)}	V
			V _{CC(A)} =1.1V to 1.95V	-	-	0.35V _{CC(A)}	V
			V _{CC(A)} =2.3V to 2.7V	-	-	0.7	V
			V _{CC(A)} =3.0V to 3.6V	-	-	0.9	V
V _{OH}	HIGH-level output voltage	V _I =V _{IH} or V _{IL} ⁽²⁾	I _O =-100uA; V _{CC(A)} =V _{CC(B)} =0.8V to 3.6V	V _{CCO} -0.1	-	-	V
			I _O =-3mA;	0.85	-	-	V

			$V_{CC(A)}=V_{CC(B)}=1.1V$				
			$I_O=-6mA;$ $V_{CC(A)}=V_{CC(B)}=1.4V$	1.05	-	-	V
			$I_O=-8mA;$ $V_{CC(A)}=V_{CC(B)}=1.65V$	1.2	-	-	V
			$I_O=-9mA;$ $V_{CC(A)}=V_{CC(B)}=2.3V$	1.75	-	-	V
			$I_O=-12mA;$ $V_{CC(A)}=V_{CC(B)}=3.0V$	2.3	-	-	V
V _{OL}	LOW-level output voltage	V _I =V _{IH} or V _{IL}	$I_O=100\mu A;$ $V_{CC(A)}=V_{CC(B)}=0.8V$ to 3.6V	-	-	0.1	V
			$I_O=3mA;$ $V_{CC(A)}=V_{CC(B)}=1.1V$	-	-	0.25	V
			$I_O=6mA;$ $V_{CC(A)}=V_{CC(B)}=1.4V$	-	-	0.35	V
			$I_O=8mA;$ $V_{CC(A)}=V_{CC(B)}=1.65V$	-	-	0.45	V
			$I_O=9mA;$ $V_{CC(A)}=V_{CC(B)}=2.3V$	-	-	0.55	V
			$I_O=12mA;$ $V_{CC(A)}=V_{CC(B)}=3.0V$	-	-	0.7	V
I _I	Input leakage current	DIR input; V _I =0V or 3.6V; V _{CC(A)}} =V _{CC(B)}} =0.8V to 3.6V		-	-	±1	uA
I _{oz}	OFF-state output current	A or B port; V _O =0V or V _{CCO} ; V _{CC(A)}} =V _{CC(B)}} =3.6V ⁽²⁾⁽³⁾		-	-	±5	uA
I _{OFF}	Power-off leakage current	A port; V _I or V _O =0V to 3.6V; V _{CC(A)}} =0V; V _{CC(B)}} =0.8V to 3.6V		-	-	±5	uA
		B port; V _I or V _O =0V to 3.6V; V _{CC(B)}} =0V; V _{CC(A)}} =0.8V to 3.6V		-	-	±5	uA
I _{CC}	Supply current	A port; V _I =0V or V _{CCI} ; I _O =0A ⁽¹⁾	V _{CC(A)}} =0.8V to 3.6V; V _{CC(B)}} =0.8V to 3.6V	-	-	8	uA
			V _{CC(A)}} =3.6V; V _{CC(B)}} =0V	-	-	8	uA
			V _{CC(A)}} =0V; V _{CC(B)}} =3.6V	-2	-	-	uA
		B port; V _I =0V or V _{CCI} ; I _O =0A ⁽¹⁾	V _{CC(A)}} =0.8V to 3.6V; V _{CC(B)}} =0.8V to 3.6V	-	-	8	uA
			V _{CC(A)}} =3.6V; V _{CC(B)}} =0V	-2	-	-	uA
			V _{CC(A)}} =0V; V _{CC(B)}} =3.6V	-	-	8	uA
		A plus B port (I _{CC(A)}} +I _{CC(B)}}); I _O =0A; V _I =0V or V _{CCI} ; V _{CC(A)}} =0.8V to 3.6V; V _{CC(B)}} =0.8V to 3.6V ⁽¹⁾		-	-	16	uA

- (1) V_{CCI} is the supply voltage associated with the data input port.
 (2) V_{CCO} is the supply voltage associated with the output port.
 (3) For I/O ports, the parameter I_{oz} includes the input leakage current.

7.4.3 DC Characteristics 3

Tamb=-40°C to +125°C, voltages are referenced to GND (ground=0V), unless otherwise specified.

SYMBOL	PARAMETER	CONDITIONS	MIN.	TYP.	MAX.	UNIT	
V _{IH}	HIGH-level input voltage	Data input ⁽¹⁾	V _{CCI} =0.8V	0.70V _{CCI}	-	-	V
			V _{CCI} =1.1V to 1.95V	0.65V _{CCI}	-	-	V
			V _{CCI} =2.3V to 2.7V	1.6	-	-	V
			V _{CCI} =3.0V to 3.6V	2	-	-	V
		DIR input	V _{CC(A)} =0.8V	0.70V _{CC(A)}	-	-	V
			V _{CC(A)} =1.1V to 1.95V	0.65V _{CC(A)}	-	-	V
			V _{CC(A)} =2.3V to 2.7V	1.6	-	-	V
			V _{CC(A)} =3.0V to 3.6V	2	-	-	V
V _{IL}	LOW-level input voltage	Data input ⁽¹⁾	V _{CCI} =0.8V	-	-	0.30V _{CCI}	V
			V _{CCI} =1.1V to 1.95V	-	-	0.35V _{CCI}	V
			V _{CCI} =2.3V to 2.7V	-	-	0.7	V
			V _{CCI} =3.0V to 3.6V	-	-	0.9	V
		DIR input	V _{CC(A)} =0.8V	-	-	0.30V _{CC(A)}	V
			V _{CC(A)} =1.1V to 1.95V	-	-	0.35V _{CC(A)}	V
			V _{CC(A)} =2.3V to 2.7V	-	-	0.7	V
			V _{CC(A)} =3.0V to 3.6V	-	-	0.9	V
V _{OH}	HIGH-level output voltage	V _I =V _{IH} or V _{IL} ⁽²⁾	I _O =-100uA; V _{CC(A)} =V _{CC(B)} =0.8V to 3.6V	V _{CCO} -0.1	-	-	V
			I _O =-3mA; V _{CC(A)} =V _{CC(B)} =1.1V	0.85	-	-	V
			I _O =-6mA; V _{CC(A)} =V _{CC(B)} =1.4V	1.05	-	-	V
			I _O =-8 mA; V _{CC(A)} =V _{CC(B)} =1.65V	1.2	-	-	V
			I _O =-9mA; V _{CC(A)} =V _{CC(B)} =2.3V	1.75	-	-	V
			I _O =-12mA; V _{CC(A)} =V _{CC(B)} =3.0V	2.3	-	-	V
			V _{OL}	LOW-level output voltage	V _I =V _{IH} or V _{IL}	I _O =100uA; V _{CC(A)} =V _{CC(B)} =0.8V to 3.6V	-
I _O =3mA; V _{CC(A)} =V _{CC(B)} =1.1V	-	-				0.25	V
I _O =6mA; V _{CC(A)} =V _{CC(B)} =1.4V	-	-				0.35	V
I _O =8mA; V _{CC(A)} =V _{CC(B)} =1.65V	-	-				0.45	V
I _O =9mA; V _{CC(A)} =V _{CC(B)} =2.3V	-	-				0.55	V
I _O =12mA; V _{CC(A)} =V _{CC(B)} =3.0V	-	-				0.7	V
I _I	Input leakage current	DIR input; V _I =0V or 3.6V; V _{CC(A)} =V _{CC(B)} =0.8V to 3.6V				-	-
I _{OZ}	OFF-state output current	A or B port; V _O =0V or V _{CCO} ; V _{CC(A)} =V _{CC(B)} =3.6V ⁽²⁾⁽³⁾	-	-	±7.5	uA	
I _{OFF}	Power-off leakage current	A port; V _I or V _O =0V to 3.6V;	-	-	±35	uA	

		$V_{CC(A)}=0V; V_{CC(B)}=0.8V \text{ to } 3.6V$					
		B port; V_I or $V_O=0V \text{ to } 3.6V$; $V_{CC(B)}=0V; V_{CC(A)}=0.8V \text{ to } 3.6V$		-	-	±35	uA
I_{CC}	Supply current	A port; $V_I=0V$ or V_{CCI} ; $I_O=0A^{(1)}$	$V_{CC(A)}=0.8V \text{ to } 3.6V$; $V_{CC(B)}=0.8V \text{ to } 3.6V$	-	-	11.5	uA
			$V_{CC(A)}=3.6V; V_{CC(B)}=0V$	-	-	11.5	uA
			$V_{CC(A)}=0V; V_{CC(B)}=3.6V$	-8	-	-	uA
		B port; $V_I=0V$ or V_{CCI} ; $I_O=0A^{(1)}$	$V_{CC(A)}=0.8V \text{ to } 3.6V$; $V_{CC(B)}=0.8V \text{ to } 3.6V$	-	-	11.5	uA
			$V_{CC(A)}=3.6V; V_{CC(B)}=0V$	-8	-	-	uA
			$V_{CC(A)}=0V; V_{CC(B)}=3.6V$	-	-	11.5	uA
		A plus B port ($I_{CC(A)}+I_{CC(B)}$); $I_O=0A; V_I=0V$ or V_{CCI} ; $V_{CC(A)}=0.8V \text{ to } 3.6V$; $V_{CC(B)}=0.8V \text{ to } 3.6V^{(1)}$		-	-	23	uA

- (1) V_{CCI} is the supply voltage associated with the data input port.
- (2) V_{CCO} is the supply voltage associated with the output port.
- (3) For I/O ports, the parameter I_{OZ} includes the input leakage current.

7.4.4 AC Characteristics 1
 $T_{amb}=25^{\circ}\text{C}$, $V_{CC(A)}=0.8\text{V}$, voltages are referenced to GND (ground=0V), unless otherwise specified⁽¹⁾⁽²⁾

SYMBOL	PARAMETER	CONDITIONS	$V_{CC(B)}$						UNIT
			0.8V	1.2V	1.5V	1.8V	2.5V	3.3V	
t_{pd}	Propagation delay	A to B ⁽¹⁾	15.5	8.1	7.6	7.7	8.4	9.2	ns
		B to A ⁽¹⁾	15.5	12.7	12.3	12.2	12.0	11.8	ns
t_{dis}	Disable time	DIR to A ⁽²⁾	12.2	12.2	12.2	12.2	12.2	12.2	ns
		DIR to B ⁽²⁾	11.7	7.9	7.6	8.2	8.7	10.2	ns
t_{en}	Enable time	DIR to A ⁽³⁾	27.2	20.6	19.9	20.4	20.7	22.0	ns
		DIR to B ⁽³⁾	27.7	20.3	19.8	19.9	20.6	21.4	ns

(1) t_{pd} is the same as t_{PLH} and t_{PHL}

(2) t_{dis} is the same as t_{PLZ} and t_{PHZ}

(3) t_{en} is the same as t_{PZL} and t_{PZH}

t_{en} is a calculated value using the formula shown in Section 5.4

7.4.5 AC Characteristics 2
 $T_{amb}=25^{\circ}\text{C}$, $V_{CC(B)}=0.8\text{V}$, voltages are referenced to GND (ground=0V), unless otherwise specified.

SYMBOL	PARAMETER	CONDITIONS	$V_{CC(A)}$						UNIT
			0.8V	1.2V	1.5V	1.8V	2.5V	3.3V	
t_{pd}	Propagation delay	A to B ⁽¹⁾	15.5	12.7	12.3	12.2	12.0	11.8	ns
		B to A ⁽¹⁾	15.5	8.1	7.6	7.7	8.4	9.2	ns
t_{dis}	Disable time	DIR to A ⁽²⁾	12.2	4.9	3.8	3.7	2.8	3.4	ns
		DIR to B ⁽²⁾	11.7	9.2	9.0	8.8	8.7	8.6	ns
t_{en}	Enable time	DIR to A ⁽³⁾	27.2	17.3	16.6	16.5	17.1	17.8	ns
		DIR to B ⁽³⁾	27.7	17.6	16.1	15.9	14.8	15.2	ns

(1) t_{pd} is the same as t_{PLH} and t_{PHL}

(2) t_{dis} is the same as t_{PLZ} and t_{PHZ}

(3) t_{en} is the same as t_{PZL} and t_{PZH}

t_{en} is a calculated value using the formula shown in Section 5.4

7.4.6 AC Characteristics 3

T_{amb}=25°C, V_{CC(A)}=V_{CC(B)}=0.8V, voltages are referenced to GND (ground=0V), unless otherwise specified.

SYMBOL	PARAMETER	CONDITIONS	V _{CC(A)} and V _{CC(B)}						UNIT	
			0.8V	1.2V	1.5V	1.8V	2.5V	3.3V		
C _{PD}	Power dissipation capacitance	A port: (direction A to B); B port: (direction B to A)	1	2	2	2	2	2	2	pF
		A port: (direction B to A); B port: (direction A to B)	9	11	11	12	14	17	pF	

Note:

(1) C_{PD} is used to determine the dynamic power dissipation (P_D in uW).

$$P_D = C_{PD} \times V_{CC}^2 \times f_i \times N + \sum (C_L \times V_{CC}^2 \times f_o)$$

where:

f_i=input frequency in MHz;

f_o=output frequency in MHz;

C_L=load capacitance in pF;

V_{CC}=supply voltage in V;

N=number of inputs switching;

∑(C_L×V_{CC}²×f_o) = sum of the outputs.

(2) f_i=10MHz; V_i=GND to V_{CC}; t_r=t_f=1ns; C_L=0pF; R_L=∞Ω.

7.4.7 AC Characteristics 4

T_{amb}=-40°C to +85°C, voltages are referenced to GND (ground=0V), unless otherwise specified.⁽¹⁾⁽²⁾

SYMBOL	PARAMETER	CONDITIONS	V _{CC(B)}										UNIT
			1.2V±0.1V		1.5V±0.1V		1.8V±0.15V		2.5V±0.2V		3.3V±0.3V		
			Min.	Max.	Min.	Max.	Min.	Max.	Min.	Max.	Min.	Max.	
t _{pd}	Propagation delay	A to B ⁽¹⁾											
		V _{CC(A)} =1.1V to 1.3V	1.0	9.0	0.7	6.8	0.6	6.1	0.5	5.7	0.5	6.1	ns
		V _{CC(A)} =1.4V to 1.6V	1.0	8.0	0.7	5.4	0.6	4.6	0.5	3.7	0.5	3.5	ns
		V _{CC(A)} =1.65V to 1.95V	1.0	7.7	0.6	5.1	0.5	4.3	0.5	3.4	0.5	3.1	ns
		V _{CC(A)} =2.3V to 2.7V	1.0	7.2	0.5	4.7	0.5	3.9	0.5	3.0	0.5	2.6	ns
		V _{CC(A)} =3.0V to 3.6V	1.0	7.1	0.5	4.5	0.5	3.7	0.5	2.8	0.5	2.4	ns
		B to A ⁽¹⁾											
		V _{CC(A)} =1.1V to 1.3V	1.0	9.0	0.8	8.0	0.7	7.7	0.6	7.2	0.5	7.1	ns
		V _{CC(A)} =1.4V to 1.6V	1.0	6.8	0.8	5.4	0.7	5.1	0.6	4.7	0.5	4.5	ns
		V _{CC(A)} =1.65V to 1.95V	1.0	6.1	0.7	4.6	0.5	4.4	0.5	3.9	0.5	3.7	ns
		V _{CC(A)} =2.3V to 2.7V	1.0	5.7	0.6	3.8	0.5	3.4	0.5	3.0	0.5	2.8	ns
V _{CC(A)} =3.0V to 3.6V	1.0	6.1	0.6	3.6	0.5	3.1	0.5	2.6	0.5	2.4	ns		
t _{dis}	Disable time	DIR to A ⁽²⁾											
		V _{CC(A)} =1.1V to 1.3V	2.2	8.8	2.2	8.8	2.2	8.8	2.2	8.8	2.2	8.8	ns
		V _{CC(A)} =1.4V to 1.6V	1.6	6.3	1.6	6.3	1.6	6.3	1.6	6.3	1.6	6.3	ns
		V _{CC(A)} =1.65V to 1.95V	1.6	5.5	1.6	5.5	1.6	5.5	1.6	5.5	1.6	5.5	ns
		V _{CC(A)} =2.3V to 2.7V	1.5	4.2	1.5	4.2	1.5	4.2	1.5	4.2	1.5	4.2	ns
		V _{CC(A)} =3.0V to 3.6V	1.5	4.7	1.5	4.7	1.5	4.7	1.5	4.7	1.5	4.7	ns
		DIR to B ⁽²⁾											

		$V_{CC(A)}=1.1V$ to $1.3V$	2.2	8.4	1.8	6.7	2.0	6.9	1.7	6.2	2.4	7.2	ns
		$V_{CC(A)}=1.4V$ to $1.6V$	2.0	7.6	1.8	5.9	1.6	6.0	1.2	4.8	1.7	5.5	ns
		$V_{CC(A)}=1.65V$ to $1.95V$	1.8	7.7	1.8	5.7	1.4	5.8	1.0	4.5	1.5	5.2	ns
		$V_{CC(A)}=2.3V$ to $2.7V$	1.7	7.3	2.0	5.2	1.5	5.1	0.6	4.2	1.1	4.8	ns
		$V_{CC(A)}=3.0V$ to $3.6V$	1.7	7.2	0.7	5.5	0.6	5.5	0.7	4.1	1.7	4.7	ns
t_{en}	Enable time	DIR to A ⁽³⁾⁽⁴⁾											
		$V_{CC(A)}=1.1V$ to $1.3V$	-	17.4	-	14.7	-	14.6	-	13.4	-	14.3	ns
		$V_{CC(A)}=1.4V$ to $1.6V$	-	14.4	-	11.3	-	11.1	-	9.5	-	10.0	ns
		$V_{CC(A)}=1.65V$ to $1.95V$	-	13.8	-	10.3	-	10.2	-	8.4	-	8.9	ns
		$V_{CC(A)}=2.3V$ to $2.7V$	-	13.0	-	9.0	-	8.5	-	7.2	-	7.6	ns
		$V_{CC(A)}=3.0V$ to $3.6V$	-	13.3	-	9.1	-	8.6	-	6.7	-	7.1	ns
		DIR to B ⁽³⁾⁽⁴⁾											
		$V_{CC(A)}=1.1V$ to $1.3V$	-	17.8	-	15.6	-	14.9	-	14.5	-	14.9	ns
		$V_{CC(A)}=1.4V$ to $1.6V$	-	14.3	-	11.7	-	10.9	-	10.0	-	9.8	ns
		$V_{CC(A)}=1.65V$ to $1.95V$	-	13.2	-	10.6	-	9.8	-	8.9	-	8.6	ns
		$V_{CC(A)}=2.3V$ to $2.7V$	-	11.4	-	8.9	-	8.1	-	7.2	-	6.8	ns
		$V_{CC(A)}=3.0V$ to $3.6V$	-	11.8	-	9.2	-	8.4	-	7.5	-	7.1	ns

- (1) t_{pd} is the same as t_{PLH} and t_{PHL}
- (2) t_{dis} is the same as t_{PLZ} and t_{PHZ}
- (3) t_{en} is the same as t_{PZL} and t_{PZH}
- (4) t_{en} is a calculated value using the formula shown in Section 5.4

7.4.8 AC Characteristics 5

$T_{amb}=-40^{\circ}C$ to $+125^{\circ}C$, voltages are referenced to GND (ground=0V), unless otherwise specified.⁽¹⁾⁽²⁾

SYMBOL	PARAMETER	CONDITIONS	$V_{CC(B)}$										UNIT
			1.2V±0.1V		1.5V±0.1V		1.8V±0.15V		2.5V±0.2V		3.3V±0.3V		
			Min.	Max.	Min.	Max.	Min.	Max.	Min.	Max.	Min.	Max.	
t_{pd}	Propagation delay	A to B ⁽¹⁾											
		$V_{CC(A)}=1.1V$ to $1.3V$	1.0	9.9	0.7	7.5	0.6	6.8	0.5	6.3	0.5	6.8	ns
		$V_{CC(A)}=1.4V$ to $1.6V$	1.0	8.8	0.7	6.0	0.6	5.1	0.5	4.1	0.5	3.9	ns
		$V_{CC(A)}=1.65V$ to $1.95V$	1.0	8.5	0.6	5.7	0.5	4.8	0.5	3.8	0.5	3.5	ns
		$V_{CC(A)}=2.3V$ to $2.7V$	1.0	8.0	0.5	5.2	0.5	4.3	0.5	3.3	0.5	2.9	ns
		$V_{CC(A)}=3.0V$ to $3.6V$	1.0	7.9	0.5	5.0	0.5	4.1	0.5	3.1	0.5	2.7	ns
		B to A ⁽¹⁾											
		$V_{CC(A)}=1.1V$ to $1.3V$	1.0	9.9	0.8	8.8	0.7	8.5	0.6	8.0	0.5	7.9	ns
		$V_{CC(A)}=1.4V$ to $1.6V$	1.0	7.5	0.8	6.0	0.7	5.7	0.6	5.2	0.5	5.0	ns
		$V_{CC(A)}=1.65V$ to $1.95V$	1.0	6.8	0.7	5.1	0.5	4.9	0.5	4.3	0.5	4.1	ns
		$V_{CC(A)}=2.3V$ to $2.7V$	1.0	6.3	0.6	4.2	0.5	3.8	0.5	3.3	0.5	3.1	ns
		$V_{CC(A)}=3.0V$ to $3.6V$	1.0	6.8	0.6	4.0	0.5	3.5	0.5	2.9	0.5	2.7	ns

t _{dis}	Disable time	DIR to A ⁽²⁾											
		V _{CC(A)} =1.1V to 1.3V	2.2	9.7	2.2	9.7	2.2	9.7	2.2	9.7	2.2	9.7	ns
		V _{CC(A)} =1.4V to 1.6V	1.6	7.0	1.6	7.0	1.6	7.0	1.6	7.0	1.6	7.0	ns
		V _{CC(A)} =1.65V to 1.95V	1.6	6.1	1.6	6.1	1.6	6.1	1.6	6.1	1.6	6.1	ns
		V _{CC(A)} =2.3V to 2.7V	1.5	4.7	1.5	4.7	1.5	4.7	1.5	4.7	1.5	4.7	ns
		V _{CC(A)} =3.0V to 3.6V	1.5	5.2	1.5	5.2	1.5	5.2	1.5	5.2	1.5	5.2	ns
		DIR to B ⁽²⁾											
		V _{CC(A)} =1.1V to 1.3V	2.2	9.2	1.8	7.4	2.0	7.6	1.7	6.9	2.4	8.0	ns
		V _{CC(A)} =1.4V to 1.6V	2.0	8.3	1.8	6.5	1.6	6.6	1.2	5.3	1.7	6.1	ns
		V _{CC(A)} =1.65V to 1.95V	1.8	8.5	1.8	6.3	1.4	6.4	1.0	5.0	1.5	5.8	ns
		V _{CC(A)} =2.3V to 2.7V	1.7	8.0	2.0	5.8	1.5	5.7	0.6	4.7	1.1	5.3	ns
		V _{CC(A)} =3.0V to 3.6V	1.7	7.9	0.7	6.1	0.6	6.1	0.7	4.6	1.7	5.2	ns
t _{en}	Enable time	DIR to A ⁽³⁾⁽⁴⁾											
		V _{CC(A)} =1.1V to 1.3V	-	19.1	-	16.2	-	16.1	-	14.9	-	15.9	ns
		V _{CC(A)} =1.4V to 1.6V	-	15.8	-	12.5	-	12.3	-	10.5	-	11.1	ns
		V _{CC(A)} =1.65V to 1.95V	-	15.3	-	11.4	-	11.3	-	9.3	-	9.9	ns
		V _{CC(A)} =2.3V to 2.7V	-	14.3	-	10.0	-	9.5	-	8.0	-	8.4	ns
		V _{CC(A)} =3.0V to 3.6V	-	14.7	-	10.1	-	9.6	-	7.5	-	7.9	ns
		DIR to B ⁽³⁾⁽⁴⁾											
		V _{CC(A)} =1.1V to 1.3V	-	19.6	-	17.2	-	16.5	-	16.0	-	16.5	ns
		V _{CC(A)} =1.4V to 1.6V	-	15.8	-	13.0	-	12.1	-	11.1	-	10.9	ns
		V _{CC(A)} =1.65V to 1.95V	-	14.6	-	11.8	-	10.9	-	9.9	-	9.6	ns
		V _{CC(A)} =2.3V to 2.7V	-	12.7	-	9.9	-	9.0	-	8.0	-	7.6	ns
		V _{CC(A)} =3.0V to 3.6V	-	13.1	-	10.2	-	9.3	-	8.3	-	7.9	ns

(1) t_{pd} is the same as t_{PLH} and t_{PHL}

(2) t_{dis} is the same as t_{PLZ} and t_{PHZ}

(3) t_{en} is the same as t_{PZL} and t_{PZH}

(4) t_{en} is a calculated value using the formula shown in Section 5.4

8 Detailed Description

8.1 Overview

The CJ74AVC2T45 is a dual-bit, dual-supply transceiver that enables bidirectional level translation. It features two data input-output ports (nA and nB), a direction control input (DIR) and dual-supply pins ($V_{CC(A)}$ and $V_{CC(B)}$). Both $V_{CC(A)}$ and $V_{CC(B)}$ can be supplied at any voltage between 0.8V and 3.6V making the device suitable for translating between any of the low voltage nodes (0.8V, 1.2V, 1.5V, 1.8V, 2.5V and 3.3V). Pins nA and DIR are referenced to $V_{CC(A)}$ and pins nB are referenced to $V_{CC(B)}$. A HIGH on DIR allows transmission from nA to nB and a LOW on DIR allows transmission from nB to nA.

The device is fully specified for partial power-down applications using I_{OFF} . The I_{OFF} circuitry disables the output, preventing any damaging backflow current through the device when it is powered down. In Suspend mode when either $V_{CC(A)}$ or $V_{CC(B)}$ are at GND level, both A and B are in the high-impedance OFF-state.

8.2 Functional Block Diagram

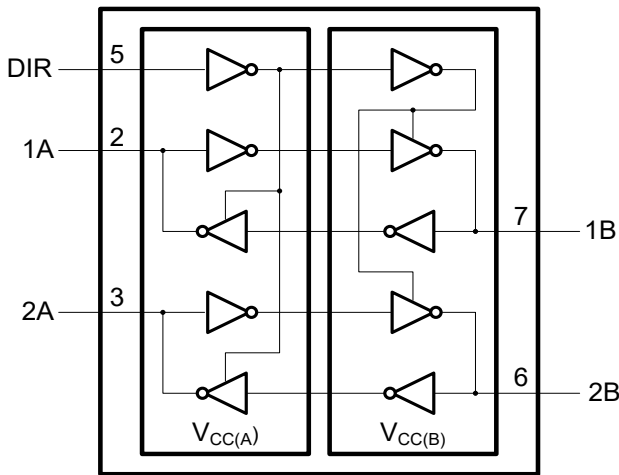

Figure 8-1 Logic symbol

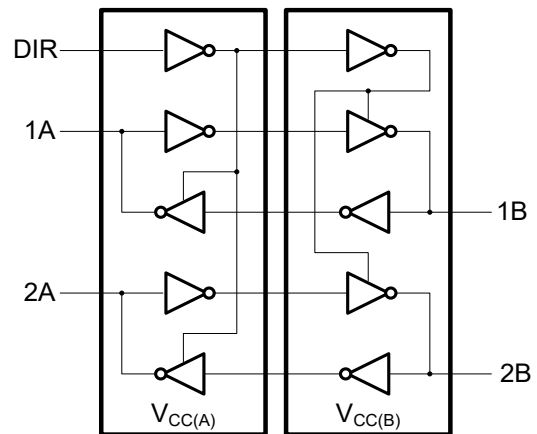

Figure 8-2 Logic diagram

8.3 Function Table⁽¹⁾

SUPPLY VOLTAGE	INPUT	INPUT/OUTPUT ⁽¹⁾	
$V_{CC(A)}, V_{CC(B)}$	DIR ⁽²⁾	nA	nB
0.8V to 3.6V	L	nA=nB	Input
0.8V to 3.6V	H	Input	nB=nA
GND ⁽³⁾	X	Z	Z

(1) The input circuit of the data I/O is always active.

(2) The DIR input circuit is referenced to $V_{CC(A)}$.

(3) If at least one of $V_{CC(A)}$ or $V_{CC(B)}$ is at GND level, the device goes into suspend mode.

8.4 Testing Circuit

8.4.1 AC Testing Circuit

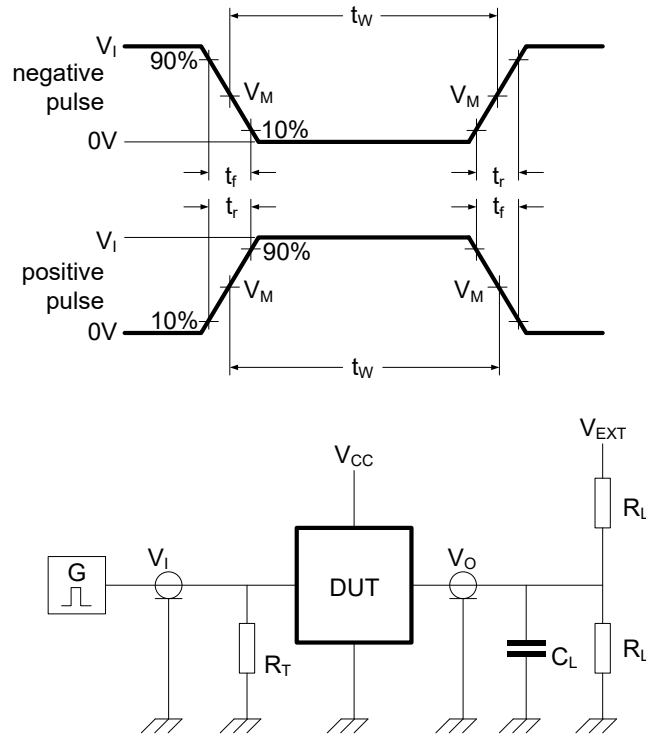

Figure 8-3 Test circuit for measuring switching times

Definitions for test circuit:

R_L =Load resistance.

C_L =Load capacitance including jig and probe capacitance.

R_T =Termination resistance.

V_{EXT} =External voltage for measuring switching times.

8.4.2 AC Testing Waveforms

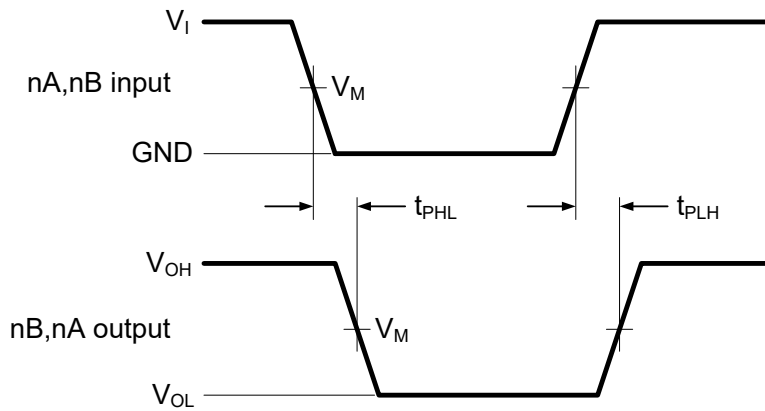

V_{OL} and V_{OH} are typical output voltage levels that occur with the output load

Figure 8-4 The data input (nA, nB) to output (nB, nA) propagation delay times

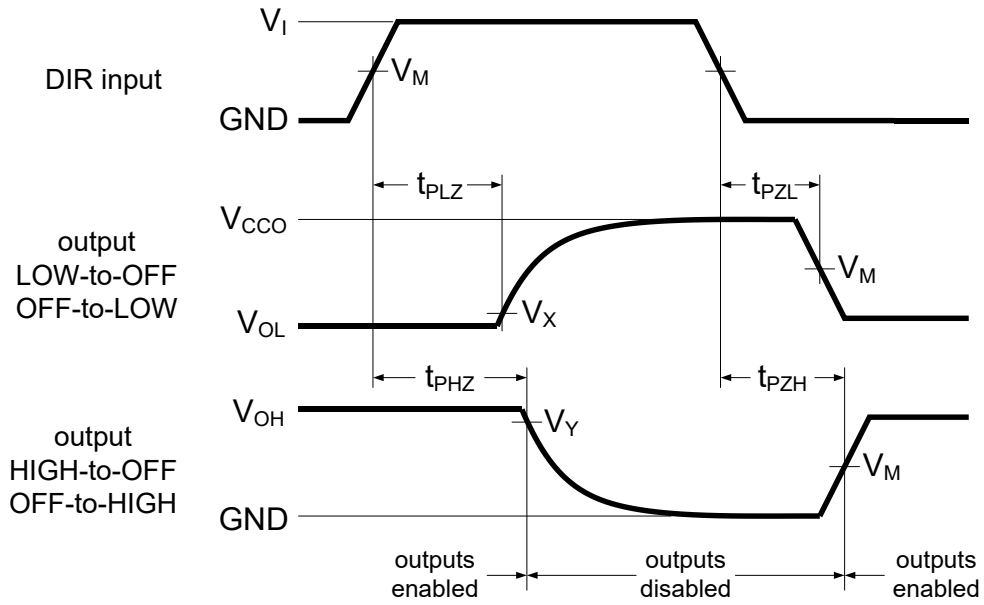

V_{OL} and V_{OH} are typical output voltage levels that occur with the output load

Figure 8-5 Enable and disable times

8.4.3 Measurement Points

SUPPLY VOLTAGE	INPUT ⁽¹⁾	OUTPUT ⁽²⁾		
$V_{CC(A)}, V_{CC(B)}$	V_M	V_M	V_X	V_Y
1.1V to 1.6V	$0.5V_{CCI}$	$0.5V_{CCO}$	$V_{OL}+0.1V$	$V_{OH}-0.1V$
1.65V to 2.7V	$0.5V_{CCI}$	$0.5V_{CCO}$	$V_{OL}+0.15V$	$V_{OH}-0.15V$
3.0V to 3.6V	$0.5V_{CCI}$	$0.5V_{CCO}$	$V_{OL}+0.3V$	$V_{OH}-0.3V$

- (1) V_{CCI} is the supply voltage associated with the data input port.
- (2) V_{CCO} is the supply voltage associated with the output port.

8.4.4 Test Data

SUPPLY VOLTAGE	INPUT		LOAD		V_{EXT}		
$V_{CC(A)}, V_{CC(B)}$	$V_I^{(1)}$	$\Delta t/\Delta V^{(2)}$	C_L	R_L	t_{PLH}, t_{PHL}	t_{PZH}, t_{PHZ}	$t_{PZL}, t_{PLZ}^{(3)}$
1.1V to 1.6V	V_{CCI}	$\leq 1.0ns/V$	15pF	2k Ω	Open	GND	2 V_{CCO}
1.65V to 2.7V	V_{CCI}	$\leq 1.0ns/V$	15pF	2k Ω	Open	GND	2 V_{CCO}
3.0V to 3.6V	V_{CCI}	$\leq 1.0ns/V$	15pF	2k Ω	Open	GND	2 V_{CCO}

- (1) V_{CCI} is the supply voltage associated with the data input port.
- (2) $dV/dt \geq 1.0V/ns$
- (3) V_{CCO} is the supply voltage associated with the output port.

9 Typical Application Circuit and Application Note

9.1 Unidirectional Logic Level-shifting Application

The circuit given in Figure 9-1 is an example of the CJ74AVC2T45 being used in an unidirectional logic level-shifting application.

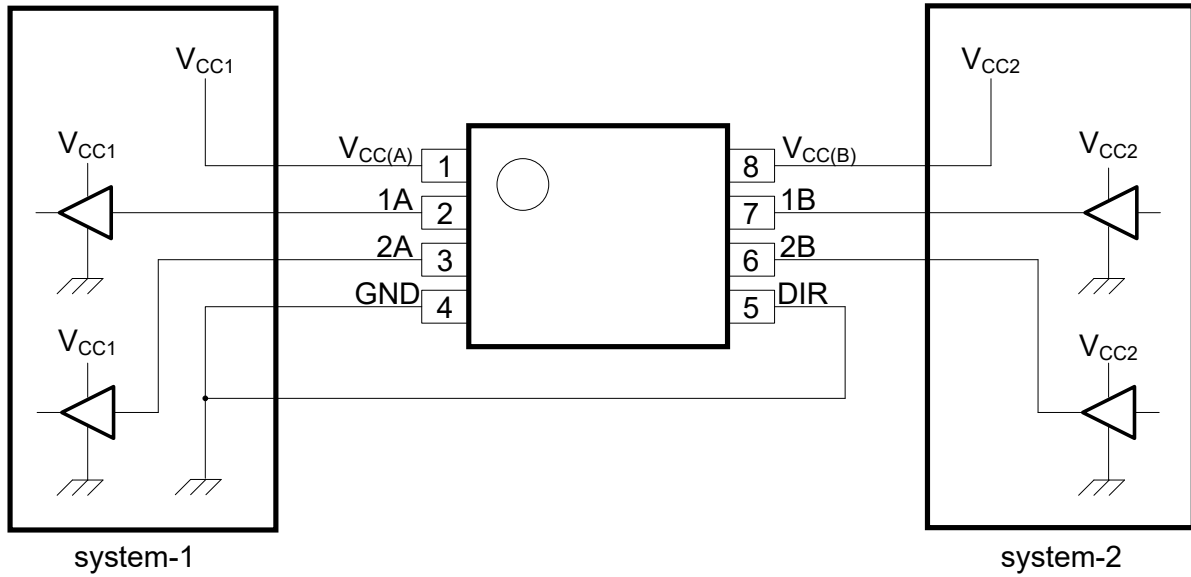

Figure 9-1 Unidirectional logic level-shifting application

Table 1 Unidirectional logic level-shifting application

PIN	NAME	FUNCTION	DESCRIPTION
1	V _{CC(A)}	V _{CC1}	Supply voltage of system-1 (0.8V to 3.6V)
2	1A	OUT1	Output level depends on V _{CC1} voltage
3	2A	OUT2	Output level depends on V _{CC1} voltage
4	GND	GND	Device GND
5	DIR	DIR	The GND (LOW level) determines B port to A port direction
6	2B	IN2	Input threshold value depends on V _{CC2} voltage
7	1B	IN1	Input threshold value depends on V _{CC2} voltage
8	V _{CC(B)}	V _{CC2}	Supply voltage of system-2 (0.8V to 3.6V)

9.2 Bidirectional Logic Level-shifting Application

Figure 9-2 shows the CJ74AVC2T45 being used in a bidirectional logic level-shifting application. Since the device does not have an output enable (OE) pin, the system designer should take precautions to avoid bus contention between system-1 and system-2 when changing directions.

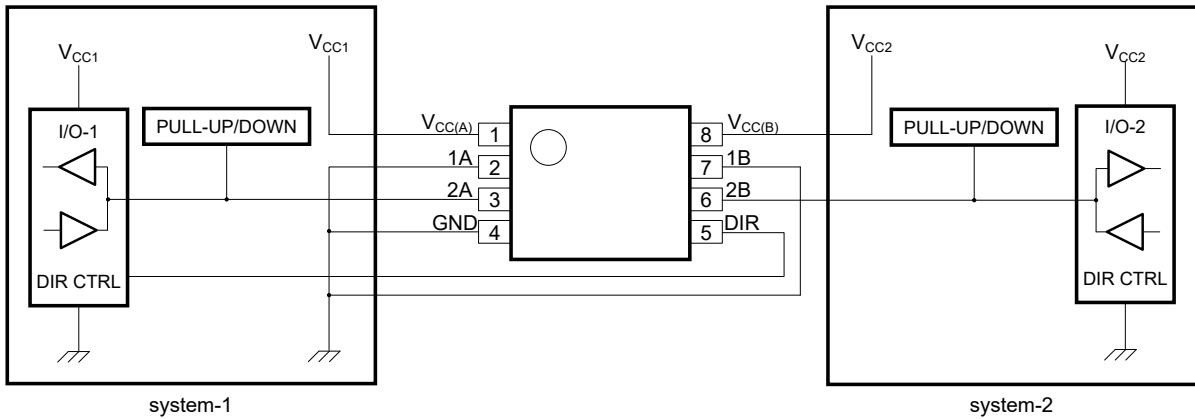

System-1 and system-2 must use the same conditions, i.e., both pull-up or both pull-down

Figure 9-2 Bidirectional logic level-shifting application

Table 2 gives a sequence that will illustrate data transmission from system-1 to system-2 and then from system-2 to system-1.

Table 2 Bidirectional logic level-shifting application

STATE	DIR CTRL	I/O-1	I/O-2	DESCRIPTION
1	H	Output	Input	System-1 data to system-2
2	H	Z	Z	System-2 is getting ready to send data to system-1. I/O-1 and I/O-2 are disabled. The bus-line state depends on the pull-up or pull-down.
3	L	Z	Z	DIR bit is set LOW. I/O-1 and I/O-2 still are disabled. The bus-line state depends on the pull-up or pull-down.
4	L	Input	Output	System-2 data to system-1

Note:

- (1) H=HIGH voltage level; L=LOW voltage level; Z=high-impedance OFF-state.
- (2) System-1 and system-2 must use the same conditions, i.e., both pull-up or both pull-down.

9.3 Power-up Considerations

The device is designed such that no special power-up sequence is required other than GND being applied first.

Table 3 Typical total supply current ($I_{CC(A)} + I_{CC(B)}$)

$V_{CC(A)}$	$V_{CC(B)}$							UNIT
	0V	0.8V	1.2V	1.5V	1.8V	2.5V	3.3V	
0V	0	0.1	0.1	0.1	0.1	0.1	0.1	uA
0.8V	0.1	0.1	0.1	0.1	0.1	0.7	2.3	uA
1.2V	0.1	0.1	0.1	0.1	0.1	0.3	1.4	uA
1.5V	0.1	0.1	0.1	0.1	0.1	0.1	0.9	uA
1.8V	0.1	0.1	0.1	0.1	0.1	0.1	0.5	uA
2.5V	0.1	0.7	0.3	0.1	0.1	0.1	0.1	uA
3.3V	0.1	2.3	1.4	0.9	0.5	0.1	0.1	uA

9.4 Enable Times

The enable times for the CJ74AVC2T45 are calculated from the following formulas:

- $t_{en} \text{ (DIR to nA)} = t_{dis} \text{ (DIR to nB)} + t_{pd} \text{ (nB to nA)}$

- $t_{en} \text{ (DIR to nB)} = t_{dis} \text{ (DIR to nA)} + t_{pd} \text{ (nA to nB)}$

In a bidirectional application, these enable times provide the maximum delay from the time the DIR bit is switched until an output is expected. For example, if the CJ74AVC2T45 initially is transmitting from A to B, then the DIR bit is switched, the B port of the device must be disabled before presenting it with an input. After the B port has been disabled, an input signal applied to it appears on the corresponding A port after the specified propagation delay.

10 Mechanical Information

10.1 TSSOP8 Mechanical Information

10.1.1 TSSOP8 Outline Dimensions

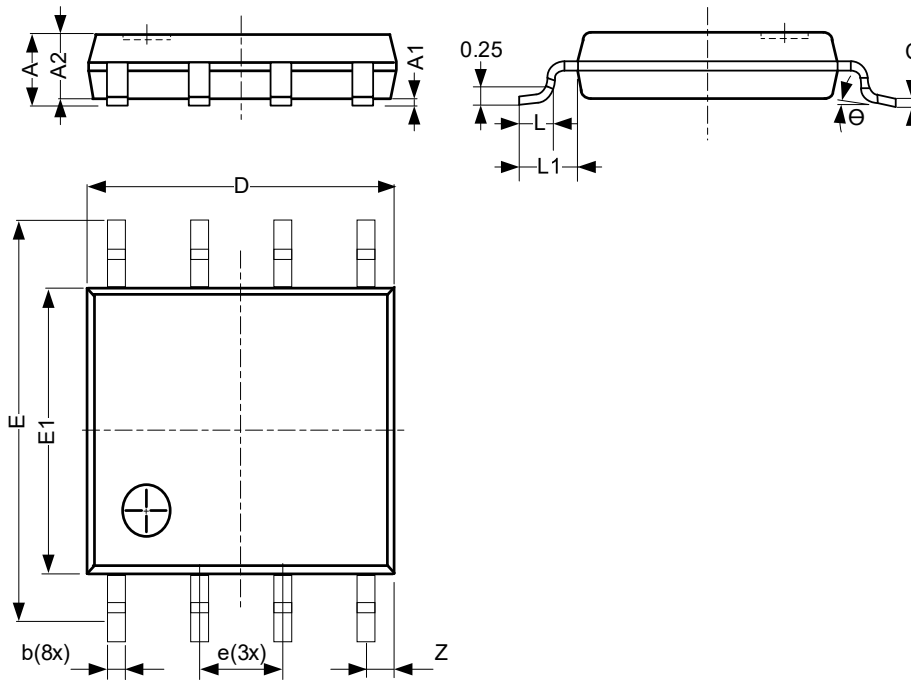

SYMBOL	Dimensions In Millimeters		
	Min.	Typ.	Max.
A	-	-	1.10
A1	0	-	0.15
A2	0.75	-	0.95
b	0.22	-	0.38
c	0.08	-	0.18
D	2.90	-	3.10
E	3.90	-	4.10
E1	2.90	-	3.10
e	0.65 BSC		
L	0.33	-	0.47
L1	-	0.50	-
Z	0.35	-	0.70
Θ	0°	-	8°
Unit: mm			

10.2 VSSOP8 Mechanical Information

10.2.1 VSSOP8 Outline Dimensions

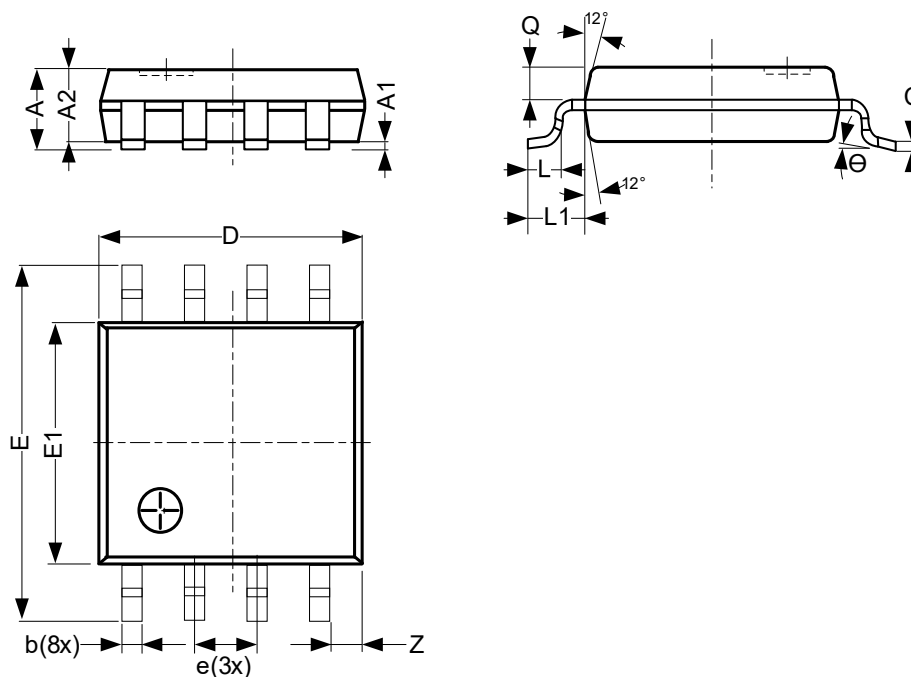

SYMBOL	Dimensions In Millimeters		
	Min.	Typ.	Max.
A	-	-	1.00
A1	0	-	0.15
A2	0.60	-	0.85
Q	0.19	-	0.21
b	0.17	-	0.27
c	0.08	-	0.23
D	1.90	-	2.10
E	3.00	-	3.20
E1	2.20	-	2.40
e	0.50 BSC		
L	0.15	-	0.40
L1	-	0.40	-
Z	0.10	-	0.40
Θ	0°	-	8°
Unit: mm			

11 Notes and Revision History

11.1 Associated Product Family and Others

To view other products of the same type or IC products of other types, click the official website of JSCJ -- <https://www.jscj-elec.com> for more details.

11.2 Notes

Electrostatic Discharge Caution



This IC may be damaged by ESD. Relevant personnel shall comply with correct installation and use specifications to avoid ESD damage to the IC. If appropriate measures are not taken to prevent ESD damage, the hazards caused by ESD include but are not limited to degradation of integrated circuit performance or complete damage of integrated circuit. For some precision integrated circuits, a very small parameter change may cause the whole device to be inconsistent with its published specifications.

DISCLAIMER

IMPORTANT NOTICE, PLEASE READ CAREFULLY

The information in this data sheet is intended to describe the operation and characteristics of our products. JSCJ has the right to make any modification, enhancement, improvement, correction or other changes to any content in this data sheet, including but not limited to specification parameters, circuit design and application information, without prior notice.

Any person who purchases or uses JSCJ products for design shall: 1. Select products suitable for circuit application and design; 2. Design, verify and test the rationality of circuit design; 3. Procedures to ensure that the design complies with relevant laws and regulations and the requirements of such laws and regulations. JSCJ makes no warranty or representation as to the accuracy or completeness of the information contained in this data sheet and assumes no responsibility for the application or use of any of the products described in this data sheet.

Without the written consent of JSCJ, this product shall not be used in occasions requiring high quality or high reliability, including but not limited to the following occasions: medical equipment, military facilities and aerospace. JSCJ shall not be responsible for casualties or property losses caused by abnormal use or application of this product.

Official Website: www.jscj-elec.com

Copyright © JIANGSU CHANGJING ELECTRONICS TECHNOLOGY CO., LTD