

8-bit Dual Supply Translating Transceiver: 3-state

CJ74AVC8T245 Logic

1 Introduction

The CJ74AVC8T245 is an 8-bit, dual supply transceiver that enables bidirectional level translation. It features two 8-bit input-output ports (An and Bn), a direction control input (DIR), a output enable input (/OE) and dual supply pins (V_{CC(A)} and V_{CC(B)}). Both V_{CC(A)} and V_{CC(B)} can be supplied at any voltage between 0.8V and 3.6V making the device suitable for translating between any of the low voltage nodes (0.8V,1.2V,1.5V,1.8V,2.5V and 3.3V). Pins An, /OE and DIR are referenced to V_{CC(A)} and pins Bn are referenced to V_{CC(B)}. A HIGH on DIR allows transmission from An to Bn and a LOW on DIR allows transmission from Bn to An. The output enable input (/OE) can be used to disable the outputs so the buses are effectively isolated.

The device is fully specified for partial power-down applications using I_{OFF}. The I_{OFF} circuitry disables the output, preventing any damaging backflow current through the device when it is powered down. In suspend mode when either V_{CC(A)} or V_{CC(B)} are at GND level, both An and Bn are in the high-impedance OFF-state.

2 Available Packages

PART NUMBER	PACKAGE
CJ74AVC8T245	TSSOP24
	QFN5.5x3.5-24L

Note: For all available packages, please refer to the part Orderable Information.

3 Features

- Wide supply voltage range:
 - V_{CC(A)}: 0.8V to 3.6V
 - V_{CC(B)}: 0.8V to 3.6V
- Maximum data rates:
 - 380 Mbit/s (≥1.8V to 3.3V translation)
 - 260 Mbit/s (≥1.1V to 3.3V translation)
 - 260 Mbit/s (≥1.1V to 2.5V translation)
 - 210 Mbit/s (≥1.1V to 1.8V translation)
 - 150 Mbit/s (≥1.1V to 1.5V translation)
 - 100 Mbit/s (≥1.1V to 1.2V translation)
- Suspend mode
- Inputs accept voltages up to 3.6V
- I_{OFF} circuitry provides partial Power-down mode operation
- Specified from -40°C to +125°C

4 Applications

- Personal electronic
- Industrial
- Enterprise
- Telecom

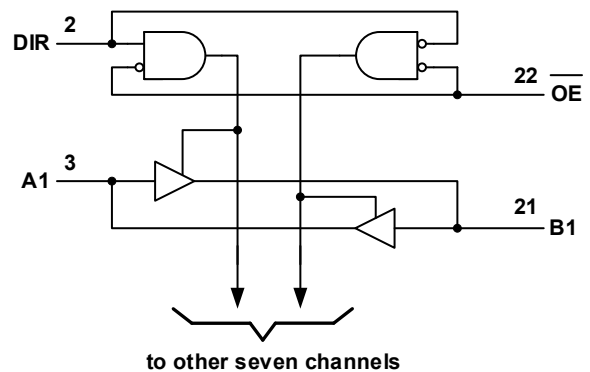

Functional diagrams

5 Orderable Information

DEVICE	PACKAGE	OP TEMP	ECO PLAN	MSL	PACKING OPTION	SORT
CJ74AVC8T245BHN	TSSOP24	-40~125°C	RoHS & Green	Level 3 168HR	Tape and Reel 4000 Units/Reel	Active
CJ74AVC8T245QFN	QFN5.5x3.5-24L	-40~125°C	RoHS & Green	Level 3 168HR	Tape and Reel 3000 Units/Reel	Active

Note:

ECO PLAN: For the RoHS and Green certification standards of this product, please refer to the official report provided by JSCJ.

MSL: Moisture Sensitivity Level. Determined according to JEDEC industry standard classification.

SORT: Specifically defined as follows:

Active: Recommended for new products;

Customized: Products manufactured to meet the specific needs of customers;

Preview: The device has been released and has not been fully mass produced. The sample may or may not be available;

NoRD: It is not recommended to use the device for new design. The device is only produced for the needs of existing customers;

Obsolete: The device has been discontinued.

6 Pin Configuration and Marking Information

6.1 Pin Configuration

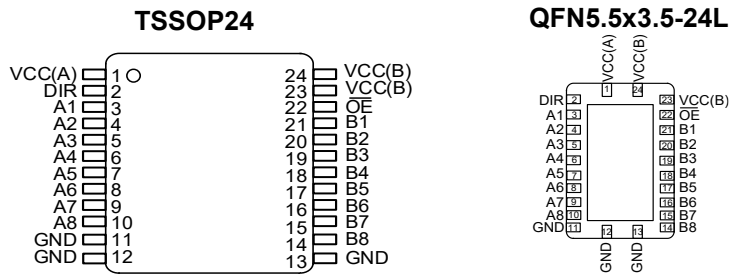

Figure 6-1 Pin configuration

6.2 Pin Function

PIN		I/O ⁽¹⁾	DESCRIPTION
No.	NAME		
1	VCC(A)	P	Supply voltage A (An, $\bar{O}E$ and DIR inputs are referenced to VCC(A))
2	DIR	-	Direction control
3,4,5,6,7,8,9,10	A1 to A8	I/O	Data input or output
11	GND ⁽¹⁾	G	Ground (0V)
12	GND ⁽¹⁾	G	Ground (0V)
13	GND ⁽¹⁾	G	Ground (0V)
21,20,19,18,17,16,15,14	B1 to B8	I/O	Data input or output
22	$\bar{O}E$	I	Output enable input (active LOW)
23	VCC(B)	P	Supply voltage B (Bn inputs are referenced to VCC(B))
24	VCC(B)	P	Supply voltage B (Bn inputs are referenced to VCC(B))

(1) All GND pins must be connected to ground (0V).

6.3 Marking Information

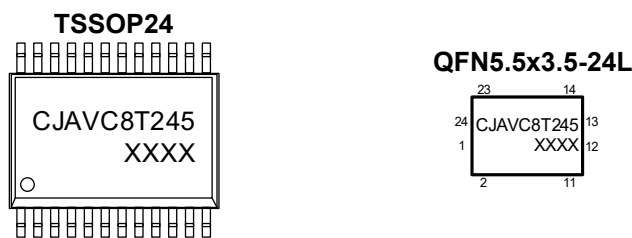

XXXX: Code, indicates weekly record information.

7 Specifications

7.1 Absolute Maximum Ratings

Voltages are referenced to GND(ground=0V), unless otherwise specified.

SYMBOL	PARAMETER	CONDITIONS	MIN.	MAX.	UNIT
$V_{CC(A)}$	Supply voltage A	-	-0.5	+4.6	V
$V_{CC(B)}$	Supply voltage B	-	-0.5	+4.6	V
I_{IK}	Input clamping current	$V_I < 0V$	-50	-	mA
V_I	Input voltage	-(¹)	-0.5	+4.6	V
I_{OK}	Output clamping current	$V_O < 0V$	-50	-	mA
V_O	Output voltage	Active mode(¹) (²) (³)	-0.5	$V_{CCO}+0.5$	V
		Suspend or 3-state mode(¹)	-0.5	+4.6	V
I_O	Output current	$V_O=0V$ to V_{CCO}	-	± 50	mA
I_{CC}	Supply current	Per $V_{CC(A)}$ or $V_{CC(B)}$ pin	-	100	mA
I_{GND}	Ground current	Per GND pin	-100	-	mA
T_{stg}	Storage temperature	-	-65	+150	°C
P_{tot}	Total power dissipation	-	-	500	mW
T_L	Soldering temperature	10s	-	260	°C

(1) The minimum input voltage ratings and output voltage ratings may be exceeded if the input and output current ratings are observed.

(2) V_{CCO} is the supply voltage associated with the output port.

(3) $V_{CCO}+0.5V$ should not exceed 4.6V.

7.2 Recommended Operating Conditions

SYMBOL	PARAMETER	CONDITIONS	MIN.	TYP.	MAX.	UNIT
$V_{CC(A)}$	Supply voltage A	-	0.8	-	3.6	V
$V_{CC(B)}$	Supply voltage B	-	0.8	-	3.6	V
V_I	Input voltage	-	0	-	3.6	V
V_O	Output voltage	Active mode(¹)	0	-	V_{CCO}	V
		Suspend or 3-state mode	0	-	3.6	V
T_{amb}	Ambient temperature	-	-40	-	+125	°C
$\Delta t/\Delta V$	Input transition rise and fall rate	$V_{CCI}=0.8V$ to $3.6V$ (²)	-	-	5	ns/V

(1) V_{CCO} is the supply voltage associated with the output port.

(2) V_{CCI} is the supply voltage associated with the input port.

7.3 ESD Ratings

SYMBOL	ESD RATINGS		VALUE	UNIT
$V_{ESD-HBM}$	Electrostatic discharge	Human body model (HBM) (¹)	± 1000	V

(1) JEDEC document JEP155 states that 500-V H1BM allows safe manufacturing with a standard ESD control process.

7.4 Electrical Characteristics

7.4.1 DC Characteristics 1

T_{amb}=25°C, voltages are referenced to GND (ground=0V), unless otherwise specified.⁽¹⁾⁽²⁾

SYMBOL	PARAMETER	CONDITIONS		MIN.	TYP.	MAX.	UNIT
V _{OH}	HIGH-level output voltage	V _I =V _{IH} or V _{IL}	I _O =-1.5mA; V _{CC(A)} =V _{CC(B)} =0.8V	-	0.69	-	V
V _{OL}	LOW-level output voltage	V _I =V _{IH} or V _{IL}	I _O =1.5mA; V _{CC(A)} =V _{CC(B)} =0.8V	-	0.07	-	V
I _I	Input leakage current	DIR, $\overline{\text{OE}}$ input; V _I =0V to 3.6V; V _{CC(A)} =V _{CC(B)} =0.8V to 3.6V		-	-	±1	uA
I _{OZ}	OFF-state output current	A or B port; V _O =0V or V _{CCO} ; V _{CC(A)} =V _{CC(B)} =3.6V ⁽³⁾		-	-	±2.5	uA
		Suspend mode A port; V _O =0V or V _{CCO} ; V _{CC(A)} =3.6V; V _{CC(B)} =0V ⁽³⁾		-	-	±2.5	uA
		Suspend mode B port; V _O =0V or V _{CCO} ; V _{CC(A)} =0V; V _{CC(B)} =3.6V ⁽³⁾		-	-	±2.5	uA
I _{OFF}	Power-off leakage current	A port; V _I or V _O =0V to 3.6V; V _{CC(A)} =0V; V _{CC(B)} =0.8V to 3.6V		-	-	±1	uA
		B port; V _I or V _O =0V to 3.6V; V _{CC(B)} =0V; V _{CC(A)} =0.8V to 3.6V		-	-	±1	uA
C _I	Input capacitance	DIR, $\overline{\text{OE}}$ input; V _I =0V or 3.3V; V _{CC(A)} =V _{CC(B)} =3.3V		-	1.5	-	pF
C _{I/O}	Input/output capacitance	A and B port; V _O =3.3V or 0V; V _{CC(A)} =V _{CC(B)} =3.3V		-	4.3	-	pF

- (1) V_{CCO} is the supply voltage associated with the output port.
- (2) V_{CCI} is the supply voltage associated with the data input port.
- (3) For I/O ports, the parameter I_{OZ} includes the input leakage current.

7.4.2 DC Characteristics 2

T_{amb}=-40°C to +85°C, voltages are referenced to GND (ground=0V), unless otherwise specified.⁽¹⁾⁽²⁾

SYMBOL	PARAMETER	CONDITIONS		MIN.	TYP.	MAX.	UNIT
V _{IH}	HIGH-level input voltage	Data input	V _{CCI} =0.8V	0.70V _{CCI}	-	-	V
			V _{CCI} =1.1V to 1.95V	0.65V _{CCI}	-	-	V
			V _{CCI} =2.3V to 2.7V	1.6	-	-	V
			V _{CCI} =3.0V to 3.6V	2	-	-	V
		DIR, $\overline{\text{OE}}$ input	V _{CC(A)} =0.8V	0.70V _{CC(A)}	-	-	V
			V _{CC(A)} =1.1V to 1.95V	0.65V _{CC(A)}	-	-	V
			V _{CC(A)} =2.3V to 2.7V	1.6	-	-	V
			V _{CC(A)} =3.0V to 3.6V	2	-	-	V
V _{IL}	LOW-level input voltage	Data input	V _{CCI} =0.8V	-	-	0.30V _{CCI}	V
			V _{CCI} =1.1V to 1.95V	-	-	0.35V _{CCI}	V
			V _{CCI} =2.3V to 2.7V	-	-	0.7	V
			V _{CCI} =3.0V to 3.6V	-	-	0.8	V
		DIR, $\overline{\text{OE}}$ input	V _{CC(A)} =0.8V	-	-	0.30V _{CC(A)}	V
			V _{CC(A)} =1.1V to 1.95V	-	-	0.35V _{CC(A)}	V

			$V_{CC(A)}=2.3V$ to $2.7V$	-	-	0.7	V
			$V_{CC(A)}=3.0V$ to $3.6V$	-	-	0.8	V
V_{OH}	HIGH-level output voltage	$V_i=V_{IH}$ or V_{IL}	$I_o=-100\mu A$; $V_{CC(A)}=V_{CC(B)}=0.8V$ to $3.6V$	$V_{CCO}-0.1$	-	-	V
			$I_o=-3mA$; $V_{CC(A)}=V_{CC(B)}=1.1V$	0.85	-	-	V
			$I_o=-6mA$; $V_{CC(A)}=V_{CC(B)}=1.4V$	1.05	-	-	V
			$I_o=-8mA$; $V_{CC(A)}=V_{CC(B)}=1.65V$	1.2	-	-	V
			$I_o=-9mA$; $V_{CC(A)}=V_{CC(B)}=2.3V$	1.75	-	-	V
			$I_o=-12mA$; $V_{CC(A)}=V_{CC(B)}=3.0V$	2.3	-	-	V
			V_{OL}	LOW-level output voltage	$V_i=V_{IH}$ or V_{IL}	$I_o=100\mu A$; $V_{CC(A)}=V_{CC(B)}=0.8V$ to $3.6V$	-
$I_o=3mA$; $V_{CC(A)}=V_{CC(B)}=1.1V$	-	-				0.25	V
$I_o=6mA$; $V_{CC(A)}=V_{CC(B)}=1.4V$	-	-				0.35	V
$I_o=8mA$; $V_{CC(A)}=V_{CC(B)}=1.65V$	-	-				0.45	V
$I_o=9mA$; $V_{CC(A)}=V_{CC(B)}=2.3V$	-	-				0.55	V
$I_o=12mA$; $V_{CC(A)}=V_{CC(B)}=3.0V$	-	-				0.7	V
I_i	Input leakage current	DIR, OE input; $V_i=0V$ or $3.6V$; $V_{CC(A)}=V_{CC(B)}=0.8V$ to $3.6V$	-	-	± 1	μA	
I_{oz}	OFF-state output current	A or B port; $V_o=0V$ or V_{CCO} ; $V_{CC(A)}=V_{CC(B)}=3.6V^{(3)}$	-	-	± 5	μA	
		Suspend mode A port; $V_o=0V$ or V_{CCO} ; $V_{CC(A)}=3.6V$; $V_{CC(B)}=0V^{(3)}$	-	-	± 5	μA	
		Suspend mode B port; $V_o=0V$ or V_{CCO} ; $V_{CC(A)}=0V$; $V_{CC(B)}=3.6V^{(3)}$	-	-	± 5	μA	
I_{OFF}	Power-off leakage current	A port; V_i or $V_o=0V$ to $3.6V$; $V_{CC(A)}=0V$; $V_{CC(B)}=0.8V$ to $3.6V$	-	-	± 5	μA	
		B port; V_i or $V_o=0V$ to $3.6V$; $V_{CC(B)}=0V$; $V_{CC(A)}=0.8V$ to $3.6V$	-	-	± 5	μA	
I_{CC}	Supply current	A port; $V_i=0V$ or V_{CCi} ; $I_o=0A$	$V_{CC(A)}=0.8V$ to $3.6V$; $V_{CC(B)}=0.8V$ to $3.6V$	-	-	10	μA
			$V_{CC(A)}=1.1V$ to $3.6V$; $V_{CC(B)}=1.1V$ to $3.6V$	-	-	8	μA
			$V_{CC(A)}=3.6V$; $V_{CC(B)}=0V$	-	-	8	μA
			$V_{CC(A)}=0V$; $V_{CC(B)}=3.6V$	-2	-	-	μA
		B port; $V_i=0V$ or V_{CCi} ; $I_o=0A$	$V_{CC(A)}=0.8V$ to $3.6V$; $V_{CC(B)}=0.8V$ to $3.6V$	-	-	10	μA
			$V_{CC(A)}=1.1V$ to $3.6V$; $V_{CC(B)}=1.1V$ to $3.6V$	-	-	8	μA
			$V_{CC(A)}=3.6V$; $V_{CC(B)}=0V$	-2	-	-	μA
			$V_{CC(A)}=0V$; $V_{CC(B)}=3.6V$	-	-	8	μA
A plus B port ($I_{CC(A)}+I_{CC(B)}$); $I_o=0A$; $V_i=0V$ or V_{CCi} ;		-	-	20	μA		

		$V_{CC(A)}=0.8V$ to $3.6V$; $V_{CC(B)}=0.8V$ to $3.6V$				
		A plus B port ($I_{CC(A)}+I_{CC(B)}$); $I_o=0A$; $V_i=0V$ or V_{CCI} ; $V_{CC(A)}=1.1V$ to $3.6V$; $V_{CC(B)}=1.1V$ to $3.6V$	-	-	16	μA

- (1) V_{CCO} is the supply voltage associated with the output port.
- (2) V_{CCI} is the supply voltage associated with the data input port.
- (3) For I/O ports, the parameter I_{oz} includes the input leakage current.

7.4.3 DC Characteristics 3

$T_{amb}=-40^{\circ}C$ to $+125^{\circ}C$, voltages are referenced to GND (ground=0V), unless otherwise specified.⁽¹⁾⁽²⁾

SYMBOL	PARAMETER	CONDITIONS		MIN.	TYP.	MAX.	UNIT
V_{IH}	HIGH-level input voltage	Data input	$V_{CCI}=0.8V$	$0.70V_{CCI}$	-	-	V
			$V_{CCI}=1.1V$ to $1.95V$	$0.65V_{CCI}$	-	-	V
			$V_{CCI}=2.3V$ to $2.7V$	1.6	-	-	V
			$V_{CCI}=3.0V$ to $3.6V$	2	-	-	V
		DIR, \overline{OE} input	$V_{CC(A)}=0.8V$	$0.70V_{CC(A)}$	-	-	V
			$V_{CC(A)}=1.1V$ to $1.95V$	$0.65V_{CC(A)}$	-	-	V
			$V_{CC(A)}=2.3V$ to $2.7V$	1.6	-	-	V
			$V_{CC(A)}=3.0V$ to $3.6V$	2	-	-	V
V_{IL}	LOW-level input voltage	Data input	$V_{CCI}=0.8V$	-	-	$0.30V_{CCI}$	V
			$V_{CCI}=1.1V$ to $1.95V$	-	-	$0.35V_{CCI}$	V
			$V_{CCI}=2.3V$ to $2.7V$	-	-	0.7	V
			$V_{CCI}=3.0V$ to $3.6V$	-	-	0.8	V
		DIR, \overline{OE} input	$V_{CC(A)}=0.8V$	-	-	$0.30V_{CC(A)}$	V
			$V_{CC(A)}=1.1V$ to $1.95V$	-	-	$0.35V_{CC(A)}$	V
			$V_{CC(A)}=2.3V$ to $2.7V$	-	-	0.7	V
			$V_{CC(A)}=3.0V$ to $3.6V$	-	-	0.8	V
V_{OH}	HIGH-level output voltage	$V_i=V_{IH}$ or V_{IL}	$I_o=-100\mu A$; $V_{CC(A)}=V_{CC(B)}=0.8V$ to $3.6V$	$V_{CCO}-0.1$	-	-	V
			$I_o=-3mA$; $V_{CC(A)}=V_{CC(B)}=1.1V$	0.85	-	-	V
			$I_o=-6mA$; $V_{CC(A)}=V_{CC(B)}=1.4V$	1.05	-	-	V
			$I_o=-8mA$; $V_{CC(A)}=V_{CC(B)}=1.65V$	1.2	-	-	V
			$I_o=-9mA$; $V_{CC(A)}=V_{CC(B)}=2.3V$	1.75	-	-	V
			$I_o=-12mA$; $V_{CC(A)}=V_{CC(B)}=3.0V$	2.3	-	-	V
V_{OL}	LOW-level output voltage	$V_i=V_{IH}$ or V_{IL}	$I_o=100\mu A$; $V_{CC(A)}=V_{CC(B)}=0.8V$ to $3.6V$	-	-	0.1	V
			$I_o=3mA$; $V_{CC(A)}=V_{CC(B)}=1.1V$	-	-	0.25	V

			$I_o=6mA;$ $V_{CC(A)}=V_{CC(B)}=1.4V$	-	-	0.35	V
			$I_o=8mA;$ $V_{CC(A)}=V_{CC(B)}=1.65V$	-	-	0.45	V
			$I_o=9mA;$ $V_{CC(A)}=V_{CC(B)}=2.3V$	-	-	0.55	V
			$I_o=12mA;$ $V_{CC(A)}=V_{CC(B)}=3.0V$	-	-	0.7	V
I_i	Input leakage current	DIR, OE input; $V_i=0V$ or $3.6V$; $V_{CC(A)}=V_{CC(B)}=0.8V$ to $3.6V$		-	-	± 5	μA
I_{oz}	OFF-state output current	A or B port; $V_o=0V$ or V_{CCO} ; $V_{CC(A)}=V_{CC(B)}=3.6V^{(3)}$		-	-	± 30	μA
		Suspend mode A port; $V_o=0V$ or V_{CCO} ; $V_{CC(A)}=3.6V$; $V_{CC(B)}=0V^{(3)}$		-	-	± 30	μA
		Suspend mode B port; $V_o=0V$ or V_{CCO} ; $V_{CC(A)}=0V$; $V_{CC(B)}=3.6V^{(3)}$		-	-	± 30	μA
I_{OFF}	Power-off leakage current	A port; V_i or $V_o=0V$ to $3.6V$; $V_{CC(A)}=0V$; $V_{CC(B)}=0.8V$ to $3.6V$		-	-	± 30	μA
		B port; V_i or $V_o=0V$ to $3.6V$; $V_{CC(B)}=0V$; $V_{CC(A)}=0.8V$ to $3.6V$		-	-	± 30	μA
I_{CC}	Supply current	A port; $V_i=0V$ or V_{CCI} ; $I_o=0A$	$V_{CC(A)}=0.8V$ to $3.6V$; $V_{CC(B)}=0.8V$ to $3.6V$	-	-	55	μA
			$V_{CC(A)}=1.1V$ to $3.6V$; $V_{CC(B)}=1.1V$ to $3.6V$	-	-	50	μA
			$V_{CC(A)}=3.6V$; $V_{CC(B)}=0V$	-	-	50	μA
			$V_{CC(A)}=0V$; $V_{CC(B)}=3.6V$	-12	-	-	μA
		B port; $V_i=0V$ or V_{CCI} ; $I_o=0A$	$V_{CC(A)}=0.8V$ to $3.6V$; $V_{CC(B)}=0.8V$ to $3.6V$	-	-	55	μA
			$V_{CC(A)}=1.1V$ to $3.6V$; $V_{CC(B)}=1.1V$ to $3.6V$	-	-	50	μA
			$V_{CC(A)}=3.6V$; $V_{CC(B)}=0V$	-12	-	-	μA
			$V_{CC(A)}=0V$; $V_{CC(B)}=3.6V$	-	-	50	μA
		A plus B port ($I_{CC(A)}+I_{CC(B)}$); $I_o=0A$; $V_i=0V$ or V_{CCI} ; $V_{CC(A)}=0.8V$ to $3.6V$; $V_{CC(B)}=0.8V$ to $3.6V$		-	-	70	μA
		A plus B port ($I_{CC(A)}+I_{CC(B)}$); $I_o=0A$; $V_i=0V$ or V_{CCI} ; $V_{CC(A)}=1.1V$ to $3.6V$; $V_{CC(B)}=1.1V$ to $3.6V$		-	-	65	μA

- (1) V_{CCO} is the supply voltage associated with the output port.
- (2) V_{CCI} is the supply voltage associated with the data input port.
- (3) For I/O ports, the parameter I_{oz} includes the input leakage current.

7.4.4 Typical Total Supply Current (I_{CC(A)}+I_{CC(B)})

V _{CC(A)}	V _{CC(B)}							UNIT
	0V	0.8V	1.2V	1.5V	1.8V	2.5V	3.3V	
0V	0	0.1	0.1	0.1	0.1	0.1	0.1	μA
0.8V	0.1	0.1	0.1	0.1	0.1	0.3	1.6	μA
1.2V	0.1	0.1	0.1	0.1	0.1	0.1	0.8	μA
1.5V	0.1	0.1	0.1	0.1	0.1	0.1	0.4	μA
1.8V	0.1	0.1	0.1	0.1	0.1	0.1	0.2	μA
2.5V	0.1	0.3	0.1	0.1	0.1	0.1	0.1	μA
3.3V	0.1	1.6	0.8	0.4	0.2	0.1	0.1	μA

7.4.5 AC Characteristics 1

V_{CC(A)}=0.8V and T_{amb}=25°C, voltages are referenced to GND (ground=0V), unless otherwise specified.

SYMBOL	PARAMETER	CONDITIONS	V _{CC(B)}						UNIT
			0.8V	1.2V	1.5V	1.8V	2.5V	3.3V	
t _{pd}	Propagation delay	An to Bn	14.4	7.0	6.2	6.0	5.9	6.0	ns
		Bn to An	14.4	12.4	12.1	11.9	11.8	11.8	ns
t _{dis}	Disable time	$\overline{\text{OE}}$ to An	16.2	16.2	16.2	16.2	16.2	16.2	ns
		$\overline{\text{OE}}$ to Bn	17.6	10.0	9.0	9.1	8.7	9.3	ns
t _{en}	Enable time	$\overline{\text{OE}}$ to An	21.9	21.9	21.9	21.9	21.9	21.9	ns
		$\overline{\text{OE}}$ to Bn	22.2	11.1	9.8	9.4	9.4	9.6	ns

Note: t_{pd} is the same as t_{PLH} and t_{PHL}; t_{dis} is the same as t_{PLZ} and t_{PHZ}; t_{en} is the same as t_{PZL} and t_{PZH}.

7.4.6 AC Characteristics 2

V_{CC(B)}=0.8V and T_{amb}=25°C, voltages are referenced to GND (ground=0V), unless otherwise specified.

SYMBOL	PARAMETER	CONDITIONS	V _{CC(A)}						UNIT
			0.8V	1.2V	1.5V	1.8V	2.5V	3.3V	
t _{pd}	Propagation delay	An to Bn	14.4	12.4	12.1	11.9	11.8	11.8	ns
		Bn to An	14.4	7.0	6.2	6.0	5.9	6.0	ns
t _{dis}	Disable time	$\overline{\text{OE}}$ to An	16.2	5.9	4.4	4.2	3.1	3.5	ns
		$\overline{\text{OE}}$ to Bn	17.6	14.2	13.7	13.6	13.3	13.1	ns
t _{en}	Enable time	$\overline{\text{OE}}$ to An	21.9	6.4	4.4	3.5	2.6	2.3	ns
		$\overline{\text{OE}}$ to Bn	22.2	17.7	17.2	17.0	16.8	16.7	ns

Note: t_{pd} is the same as t_{PLH} and t_{PHL}; t_{dis} is the same as t_{PLZ} and t_{PHZ}; t_{en} is the same as t_{PZL} and t_{PZH}.

7.4.7 AC Characteristics 3

V_{CC(A)}= V_{CC(B)} and T_{amb}=25°C, voltages are referenced to GND (ground=0V), unless otherwise specified.

SYMBOL	PARAMETER	CONDITIONS	V _{CC(A)} =V _{CC(B)}						UNIT
			0.8V	1.2V	1.5V	1.8V	2.5V	3.3V	

C _{PD}	Power dissipation capacitance	A port: (direction An to Bn); Output enabled	0.2	0.2	0.2	0.3	0.4	0.5	pF
		A port: (direction An to Bn); Output disabled	0.2	0.2	0.2	0.3	0.4	0.5	pF
		A port: (direction Bn to An); Output enabled	9	9	10	10	11	13	pF
		A port: (direction Bn to An); Output disabled	0.6	0.6	0.6	0.7	0.7	0.8	pF
		B port: (direction An to Bn); Output enabled	9	9	10	10	11	13	pF
		B port: (direction An to Bn); Output disabled	0.6	0.6	0.6	0.7	0.7	0.8	pF
		B port: (direction Bn to An); Output enabled	0.2	0.2	0.2	0.3	0.4	0.5	pF
		B port: (direction Bn to An); Output disabled	0.2	0.2	0.2	0.3	0.4	0.5	pF

Note:

- (1) C_{PD} is used to determine the dynamic power dissipation (P_D in uW).
- (2) $P_D = C_{PD} \times V_{CC}^2 \times f_i \times N + \sum(C_L \times V_{CC}^2 \times f_o)$ where:
- (3) f_i=input frequency in MHz;
 f_o=output frequency in MHz;
 C_L=load capacitance in pF;
 V_{CC}=supply voltage in V;
 N=number of inputs switching;
 $\sum(C_L \times V_{CC}^2 \times f_o)$ =sum of the outputs.
 f_i=10MHz; V_i=GND to V_{CC}; t_r=t_f=1ns; C_L=0pF; R_L=∞Ω.

7.4.8 AC Characteristics 4

T_{amb}=-40°C to +85°C, voltages are referenced to GND (ground=0V), unless otherwise specified.

SYMBOL	PARAMETER	CONDITIONS	V _{CC(B)}										UNIT
			1.2V±0.1V		1.5V±0.1V		1.8V±0.15V		2.5V±0.2V		3.3V±0.3V		
			MIN.	MAX.	MIN.	MAX.	MIN.	MAX.	MIN.	MAX.	MIN.	MAX.	
V_{CC(A)}=1.1V to 1.3V													
t _{pd}	Propagation Delay	An to Bn	0.5	9.0	0.5	6.7	0.5	5.8	0.5	4.9	0.5	4.8	ns
		Bn to An	0.5	9.0	0.5	8.5	0.5	8.3	0.5	8.0	0.5	7.8	ns
t _{dis}	Disable time	\overline{OE} to An	0.5	11.8	0.5	11.8	0.5	11.8	0.5	11.8	0.5	11.8	ns
		\overline{OE} to Bn	0.5	12.3	0.5	9.5	0.5	9.4	0.5	8.0	0.5	8.9	ns
t _{en}	Enable time	\overline{OE} to An	1.1	14.4	1.1	14.4	1.1	14.4	1.1	14.4	1.1	14.4	ns
		\overline{OE} to Bn	1.1	14.2	1.1	10.4	1.1	9.0	1.0	7.7	1.0	7.3	ns
V_{CC(A)}=1.4V to 1.6V													
t _{pd}	Propagation Delay	An to Bn	0.5	8.5	0.5	5.6	0.5	4.7	0.5	4.4	0.5	4.1	ns
		Bn to An	0.5	6.7	0.5	5.6	0.5	5.3	0.5	5.2	0.5	5.0	ns
t _{dis}	Disable time	\overline{OE} to An	0.5	8.6	0.5	8.6	0.5	8.6	0.5	8.6	0.5	8.6	ns
		\overline{OE} to Bn	0.5	11.2	0.5	8.4	0.5	7.6	0.5	7.2	0.5	7.8	ns
t _{en}	Enable time	\overline{OE} to An	1.1	8.7	1.1	8.7	1.1	8.7	1.1	8.7	1.1	8.7	ns
		\overline{OE} to Bn	1.1	12.8	1.1	8.1	1.1	7.1	1.0	5.6	1.0	5.2	ns
V_{CC(A)}=1.65V to 1.95V													

t_{pd}	Propagation Delay	An to Bn	0.5	8.3	0.5	5.3	0.5	4.5	0.5	3.8	0.5	3.5	ns
		Bn to An	0.5	5.8	0.5	4.7	0.5	4.5	0.5	4.3	0.5	4.1	ns
t_{dis}	Disable time	\overline{OE} to An	0.5	7.1	0.5	7.1	0.5	7.1	0.5	7.1	0.5	7.1	ns
		\overline{OE} to Bn	0.5	10.9	0.5	7.8	0.5	6.9	0.5	6.0	0.5	5.8	ns
t_{en}	Enable time	\overline{OE} to An	1.0	6.8	1.0	6.8	1.0	6.8	1.0	6.8	1.0	6.8	ns
		\overline{OE} to Bn	1.1	12.4	1.1	8.2	1.0	6.7	0.5	5.1	0.5	4.5	ns
$V_{CC(A)}=2.3V$ to $2.7V$													
t_{pd}	Propagation Delay	An to Bn	0.5	8.0	0.5	5.2	0.5	4.3	0.5	3.3	0.5	2.9	ns
		Bn to An	0.5	4.9	0.5	4.4	0.5	3.8	0.5	3.3	0.5	3.1	ns
t_{dis}	Disable time	\overline{OE} to An	0.5	5.1	0.5	5.1	0.5	5.1	0.5	5.1	0.5	5.1	ns
		\overline{OE} to Bn	0.5	10.4	0.5	7.1	0.5	6.3	0.5	5.1	0.5	5.2	ns
t_{en}	Enable time	\overline{OE} to An	0.5	4.8	0.5	4.8	0.5	4.8	0.5	4.8	0.5	4.8	ns
		\overline{OE} to Bn	1.1	11.9	1.1	7.9	0.5	6.4	0.5	4.6	0.5	4.0	ns
$V_{CC(A)}=3.0V$ to $3.6V$													
t_{pd}	Propagation Delay	An to Bn	0.5	7.8	0.5	5.0	0.5	4.1	0.5	3.1	0.5	2.7	ns
		Bn to An	0.5	4.8	0.5	4.1	0.5	3.5	0.5	2.9	0.5	2.7	ns
t_{dis}	Disable time	\overline{OE} to An	0.5	4.9	0.5	4.9	0.5	4.9	0.5	4.9	0.5	4.9	ns
		\overline{OE} to Bn	0.5	10.1	0.5	6.9	0.5	6.0	0.5	4.8	0.5	5.0	ns
t_{en}	Enable time	\overline{OE} to An	0.5	4.0	0.5	4.0	0.5	4.0	0.5	4.0	0.5	4.0	ns
		\overline{OE} to Bn	1.1	11.7	1.1	7.8	0.5	6.2	0.5	4.5	0.5	3.9	ns

Note: t_{pd} is the same as t_{PLH} and t_{PHL} ; t_{dis} is the same as t_{PLZ} and t_{PHZ} ; t_{en} is the same as t_{PZL} and t_{PZH} .

7.4.9 AC Characteristics 5

$T_{amb}=-40^{\circ}C$ to $+125^{\circ}C$, voltages are referenced to GND (ground=0V), unless otherwise specified.

SYMBOL	PARAMETER	CONDITIONS	$V_{CC(B)}$										UNIT
			1.2V±0.1V		1.5V±0.1V		1.8V±0.15V		2.5V±0.2V		3.3V±0.3V		
			MIN.	MAX.	MIN.	MAX.	MIN.	MAX.	MIN.	MAX.	MIN.	MAX.	
$V_{CC(A)}=1.1V$ to $1.3V$													
t_{pd}	Propagation Delay	An to Bn	0.5	9.9	0.5	7.4	0.5	6.4	0.5	5.4	0.5	5.3	ns
		Bn to An	0.5	9.9	0.5	9.4	0.5	9.2	0.5	8.8	0.5	8.6	ns
t_{dis}	Disable time	\overline{OE} to An	0.5	13.0	0.5	13.0	0.5	13.0	0.5	13.0	0.5	13.0	ns
		\overline{OE} to Bn	0.5	13.6	0.5	10.5	0.5	10.4	0.5	8.8	0.5	9.8	ns
t_{en}	Enable time	\overline{OE} to An	1.1	15.9	1.1	15.9	1.1	15.9	1.1	15.9	1.1	15.9	ns
		\overline{OE} to Bn	1.1	15.7	1.1	11.5	1.1	9.9	1.0	8.5	1.0	8.1	ns
$V_{CC(A)}=1.4V$ to $1.6V$													
t_{pd}	Propagation Delay	An to Bn	0.5	9.4	0.5	6.2	0.5	5.2	0.5	4.9	0.5	4.6	ns
		Bn to An	0.5	7.4	0.5	6.2	0.5	5.9	0.5	5.8	0.5	5.5	ns
	Disable time	\overline{OE} to An	0.5	9.5	0.5	9.5	0.5	9.5	0.5	9.5	0.5	9.5	ns

t_{dis}		\overline{OE} to Bn	0.5	12.4	0.5	9.3	0.5	8.4	0.5	8.0	0.5	8.6	ns
t_{en}	Enable time	\overline{OE} to An	1.1	9.6	1.1	9.6	1.1	9.6	1.1	9.6	1.1	9.6	ns
		\overline{OE} to Bn	1.1	14.1	1.1	9.0	1.1	7.9	1.0	6.2	1.0	5.8	ns
$V_{CC(A)}=1.65V$ to $1.95V$													
t_{pd}	Propagation Delay	An to Bn	0.5	9.2	0.5	5.9	0.5	5.0	0.5	4.2	0.5	3.9	ns
		Bn to An	0.5	6.4	0.5	5.2	0.5	5.0	0.5	4.8	0.5	4.6	ns
t_{dis}	Disable time	\overline{OE} to An	0.5	7.9	0.5	7.9	0.5	7.9	0.5	7.9	0.5	7.9	ns
		\overline{OE} to Bn	0.5	12.0	0.5	8.6	0.5	7.6	0.5	6.6	0.5	6.4	ns
t_{en}	Enable time	\overline{OE} to An	1.0	7.5	1.0	7.5	1.0	7.5	1.0	7.5	1.0	7.5	ns
		\overline{OE} to Bn	1.1	13.7	1.1	9.1	1.0	7.4	0.5	5.7	0.5	5.0	ns
$V_{CC(A)}=2.3V$ to $2.7V$													
t_{pd}	Propagation Delay	An to Bn	0.5	8.8	0.5	5.8	0.5	4.8	0.5	3.7	0.5	3.2	ns
		Bn to An	0.5	5.4	0.5	4.9	0.5	4.2	0.5	3.7	0.5	3.5	ns
t_{dis}	Disable time	\overline{OE} to An	0.5	5.7	0.5	5.7	0.5	5.7	0.5	5.7	0.5	5.7	ns
		\overline{OE} to Bn	0.5	11.5	0.5	7.9	0.5	7.0	0.5	5.7	0.5	5.8	ns
t_{en}	Enable time	\overline{OE} to An	0.5	5.3	0.5	5.3	0.5	5.3	0.5	5.3	0.5	5.3	ns
		\overline{OE} to Bn	1.1	13.1	1.1	8.7	0.5	7.1	0.5	5.1	0.5	4.4	ns
$V_{CC(A)}=3.0V$ to $3.6V$													
t_{pd}	Propagation Delay	An to Bn	0.5	8.6	0.5	5.5	0.5	4.6	0.5	3.5	0.5	3.0	ns
		Bn to An	0.5	5.3	0.5	4.6	0.5	3.9	0.5	3.2	0.5	3.0	ns
t_{dis}	Disable time	\overline{OE} to An	0.5	5.4	0.5	5.4	0.5	5.4	0.5	5.4	0.5	5.4	ns
		\overline{OE} to Bn	0.5	11.2	0.5	7.6	0.5	6.6	0.5	5.3	0.5	5.5	ns
t_{en}	Enable time	\overline{OE} to An	0.5	4.4	0.5	4.4	0.5	4.4	0.5	4.4	0.5	4.4	ns
		\overline{OE} to Bn	1.1	12.9	1.1	8.6	0.5	6.9	0.5	5.0	0.5	4.3	ns

Note: t_{pd} is the same as t_{PLH} and t_{PHL} ; t_{dis} is the same as t_{PLZ} and t_{PHZ} ; t_{en} is the same as t_{PZL} and t_{PZH} .

8 Detailed Description

8.1 Overview

The CJ74AVC8T245 is an 8-bit, dual supply transceiver that enables bidirectional level translation. It features two 8-bit input-output ports (An and Bn), a direction control input (DIR), a output enable input (/OE) and dual supply pins (V_{CC(A)} and V_{CC(B)}). Both V_{CC(A)} and V_{CC(B)} can be supplied at any voltage between 0.8V and 3.6V making the device suitable for translating between any of the low voltage nodes (0.8V,1.2V,1.5V,1.8V,2.5V and 3.3V). Pins An, /OE and DIR are referenced to V_{CC(A)} and pins Bn are referenced to V_{CC(B)}. A HIGH on DIR allows transmission from An to Bn and a LOW on DIR allows transmission from Bn to An. The output enable input (/OE) can be used to disable the outputs so the buses are effectively isolated.

The device is fully specified for partial power-down applications using I_{OFF}. The I_{OFF} circuitry disables the output, preventing any damaging backflow current through the device when it is powered down. In suspend mode when either V_{CC(A)} or V_{CC(B)} are at GND level, both An and Bn are in the high-impedance OFF-state.

8.2 Functional Block Diagram

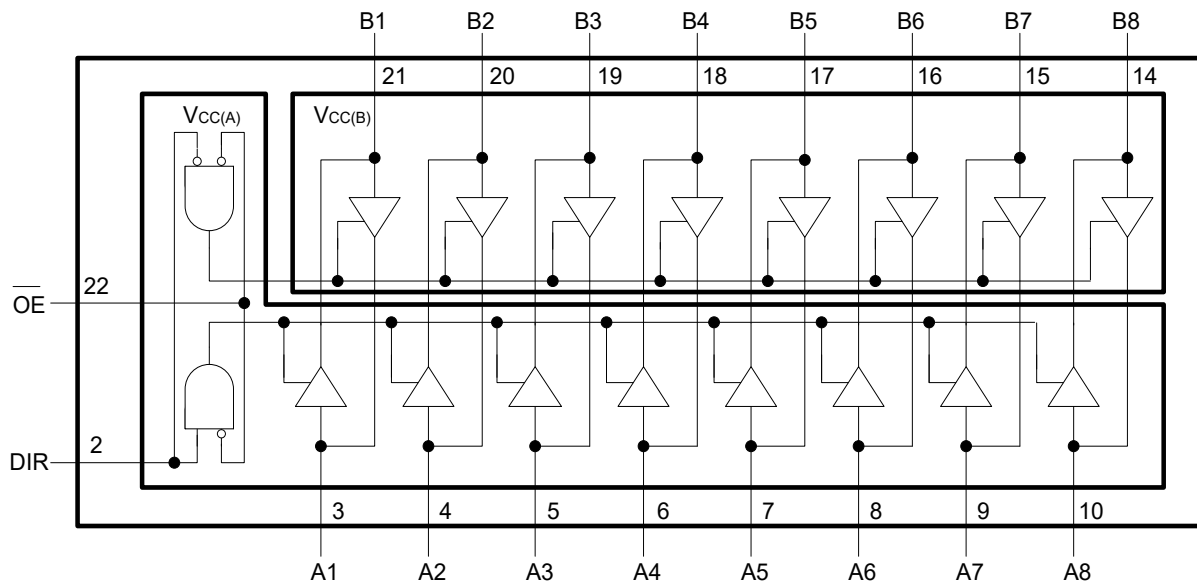

Figure 8-1 Logic symbol

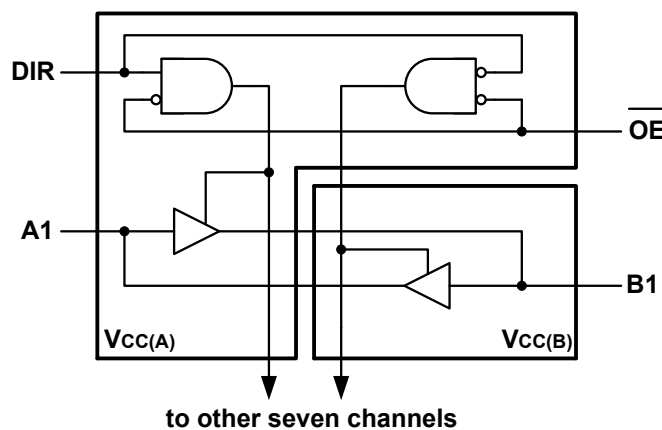

Figure 8-2 Logic diagram

8.3 Function Table

SUPPLY VOLTAGE	INPUT		INPUT/OUTPUT	
$V_{CC(A)}, V_{CC(B)}$	\overline{OE}	DIR	An	Bn
0.8V to 3.6V	L	L	An=Bn	input
0.8V to 3.6V	L	H	input	Bn=An
0.8V to 3.6V	H	X	Z	Z
GND	X	X	Z	Z

Note:

- (1) H=HIGH voltage level; L=LOW voltage level; X=don't care; Z=high-impedance OFF-state.
- (2) The An, DIR and \overline{OE} input circuit is referenced to $V_{CC(A)}$; The Bn input circuit is referenced to $V_{CC(B)}$.
- (3) If at least one of $V_{CC(A)}$ or $V_{CC(B)}$ is at GND level, the device goes into suspend mode.

8.4 Testing Circuit

8.4.1 AC Testing Circuit

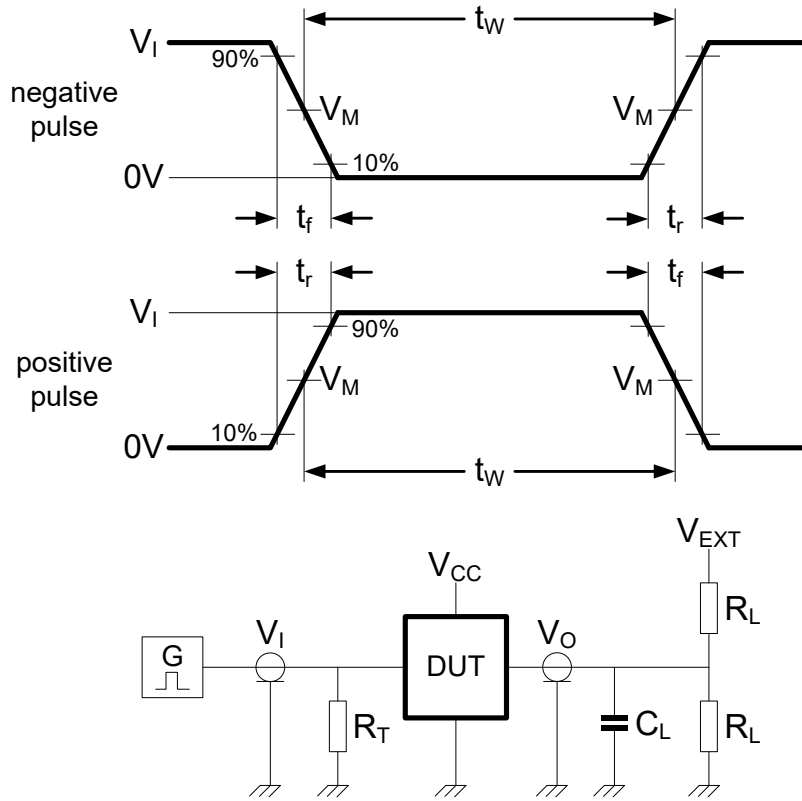

Figure 8-3 Load circuitry for switching times

Definitions for test circuit:

R_L =Load resistance.

C_L =Load capacitance including jig and probe capacitance.

R_T =Termination resistance.

V_{EXT} =External voltage for measuring switching times.

8.4.2 AC Testing Waveforms

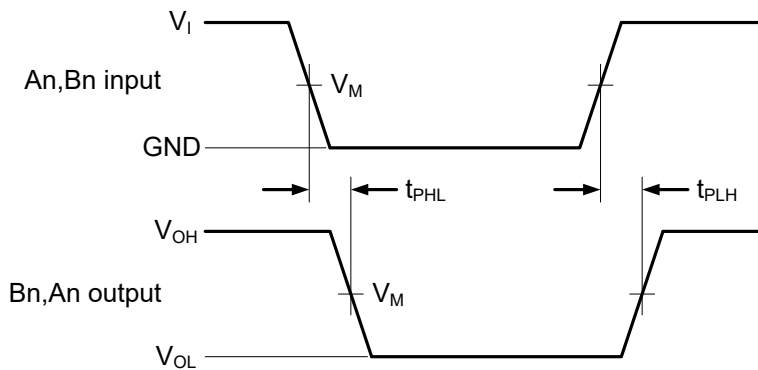

Figure 8-4 The data input (An, Bn) to output (Bn, An) propagation delay times (V_{OL} and V_{OH} are typical output voltage levels that occur with the output load.)

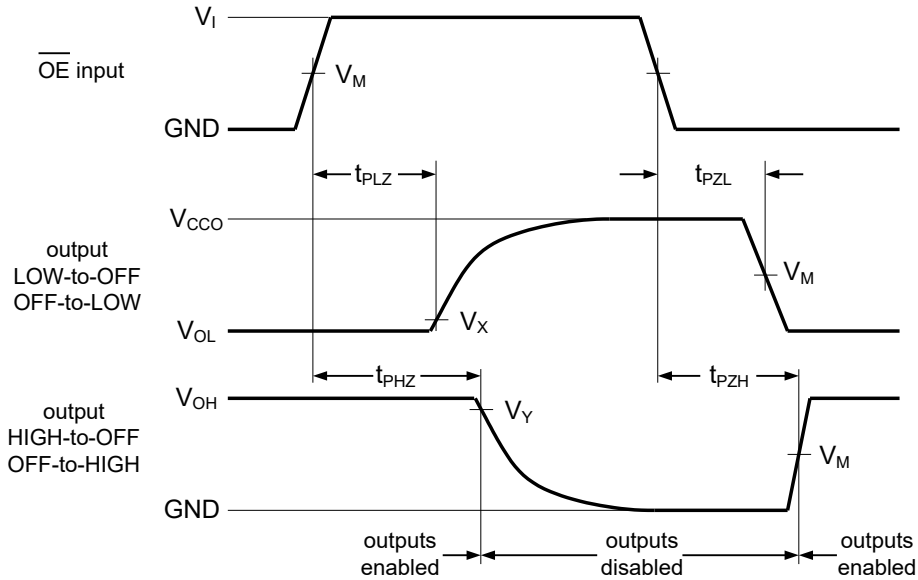

Figure 8-5 Enable and disable times
 (V_{OL} and V_{OH} are typical output voltage levels that occur with the output load.)

8.4.3 Measurement Points

SUPPLY VOLTAGE	INPUT ⁽¹⁾	OUTPUT ⁽²⁾		
$V_{CC(A)}, V_{CC(B)}$	V_M	V_M	V_X	V_Y
0.8V to 1.6V	$0.5V_{CCI}$	$0.5V_{CCO}$	$V_{OL}+0.1V$	$V_{OH}-0.1V$
1.65V to 2.7V	$0.5V_{CCI}$	$0.5V_{CCO}$	$V_{OL}+0.15V$	$V_{OH}-0.15V$
3.0V to 3.6V	$0.5V_{CCI}$	$0.5V_{CCO}$	$V_{OL}+0.3V$	$V_{OH}-0.3V$

(1) V_{CCI} is the supply voltage associated with the data input port.

(2) V_{CCO} is the supply voltage associated with the output port.

8.4.4 Test Data

SUPPLY VOLTAGE	INPUT		LOAD		V_{EXT}		
$V_{CC(A)}, V_{CC(B)}$	$V_I^{(1)}$	$\Delta t/\Delta V^{(2)}$	C_L	R_L	t_{PLH}, t_{PHL}	t_{PZH}, t_{PHZ}	$t_{PZL}, t_{PLZ}^{(3)}$
0.8V to 1.6V	V_{CCI}	$\leq 1.0ns/V$	15pF	2k Ω	Open	GND	$2V_{CCO}$
1.65V to 2.7V	V_{CCI}	$\leq 1.0ns/V$	15pF	2k Ω	Open	GND	$2V_{CCO}$
3.0V to 3.6V	V_{CCI}	$\leq 1.0ns/V$	15pF	2k Ω	Open	GND	$2V_{CCO}$

(1) V_{CCI} is the supply voltage associated with the data input port.

(2) $dV/dt \geq 1.0V/ns$.

(3) V_{CCO} is the supply voltage associated with the output port.

9 Characteristic Curve

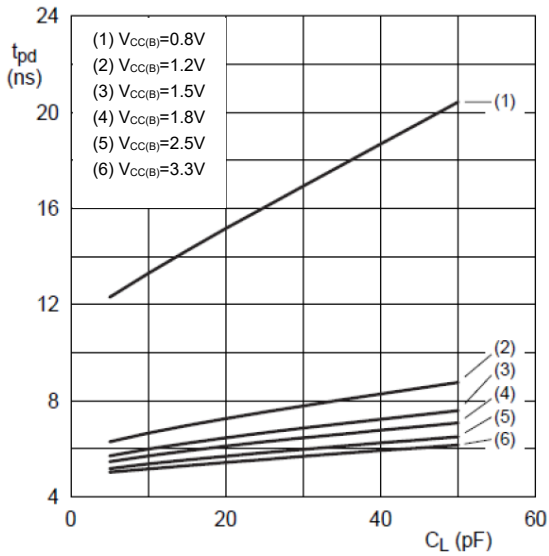

a. Propagation delay (An to Bn); $V_{CC(A)}=0.8V$

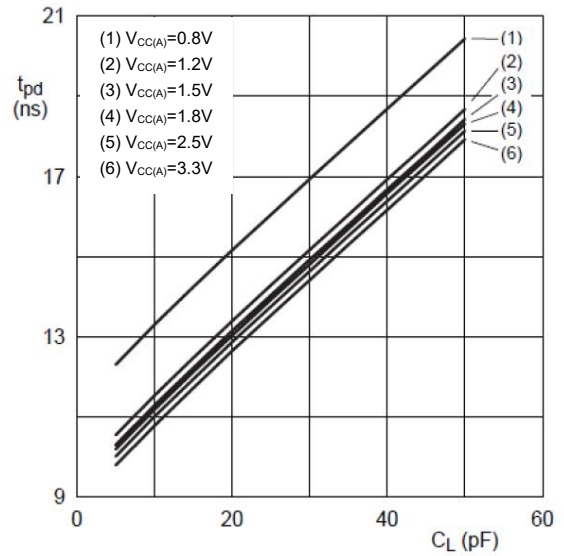

b. Propagation delay (An to Bn); $V_{CC(B)}=0.8V$

Figure 9-1 Typical propagation delay versus load capacitance; $T_{amb}=25^{\circ}C$

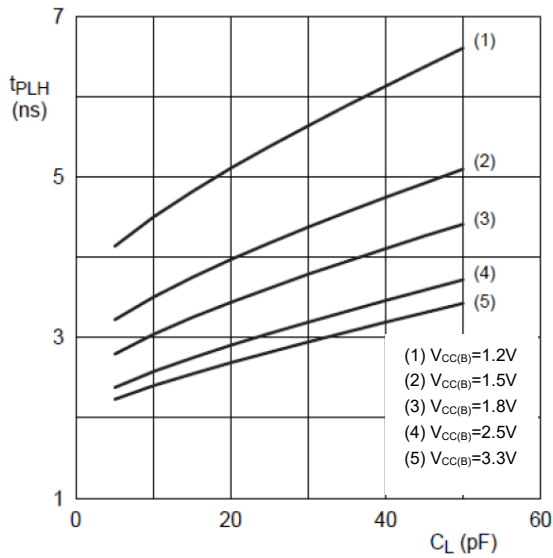

a. LOW to HIGH propagation delay (An to Bn);
V_{CC(A)}=1.2V

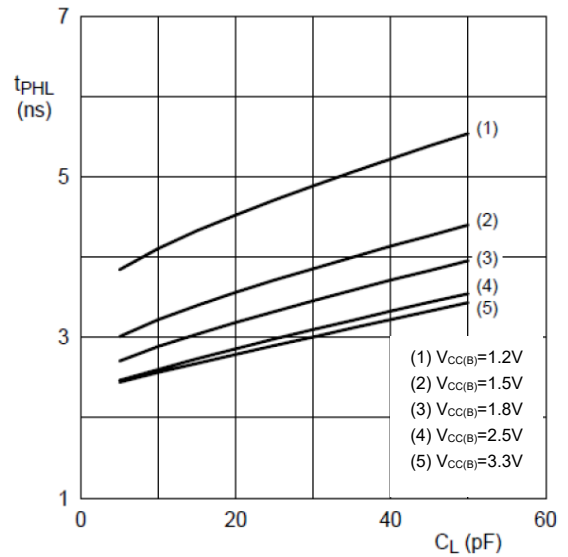

b. HIGH to LOW propagation delay (An to Bn);
V_{CC(A)}=1.2V

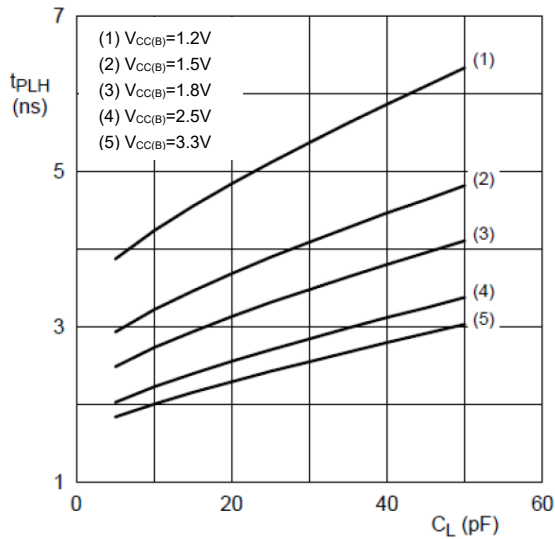

c. LOW to HIGH propagation delay (An to Bn);
V_{CC(A)}=1.5V

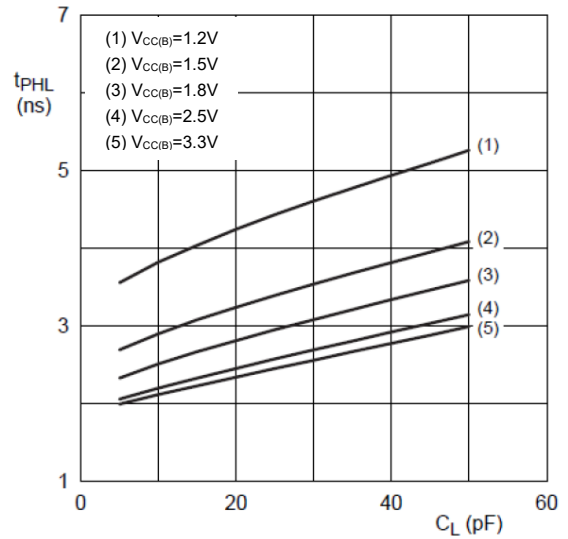

d. HIGH to LOW propagation delay (An to Bn);
V_{CC(A)}=1.5V

Figure 9-2 Typical propagation delay versus load capacitance; T_{amb}=25°C

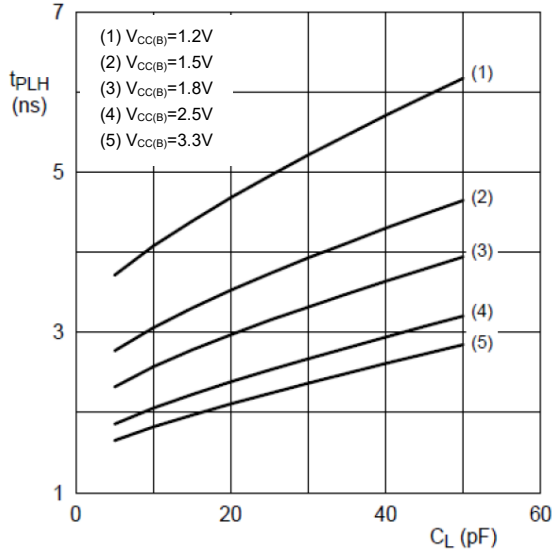

a. LOW to HIGH propagation delay (An to Bn);
V_{CC(A)}=1.8V

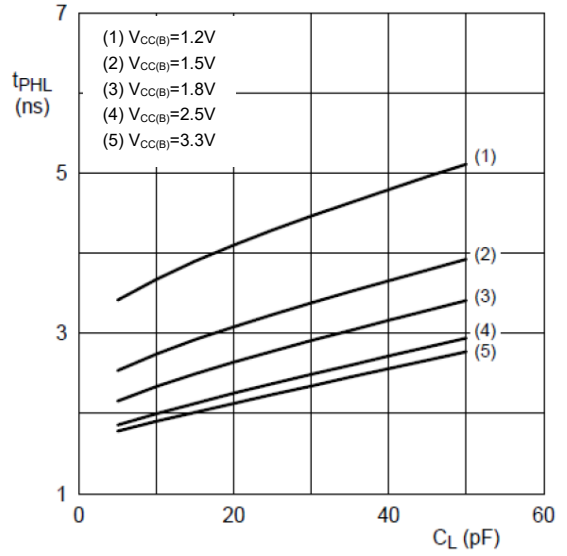

b. HIGH to LOW propagation delay (An to Bn);
V_{CC(A)}=1.8V

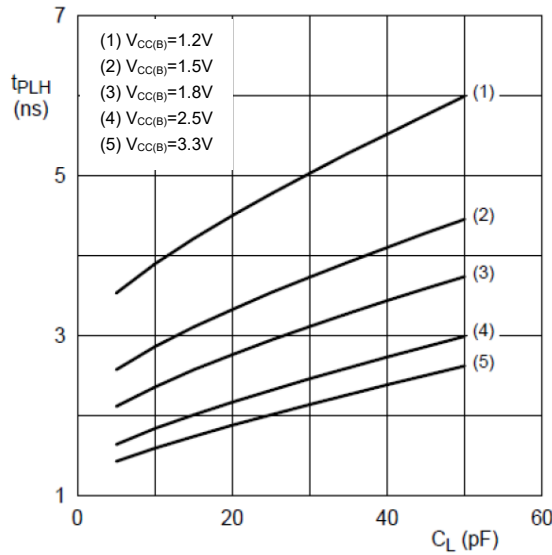

c. LOW to HIGH propagation delay (An to Bn);
V_{CC(A)}=2.5V

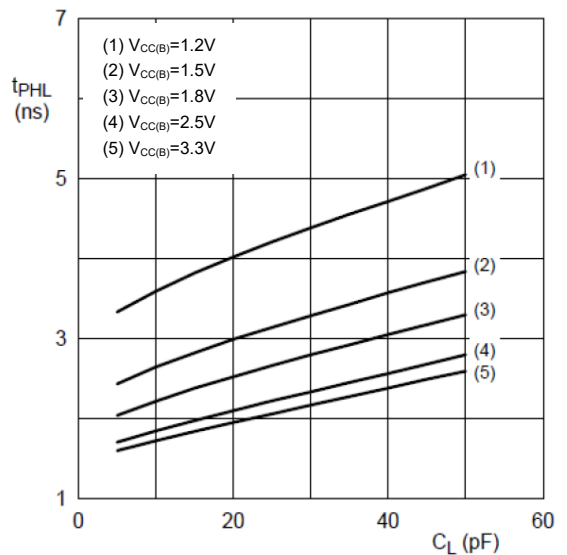

d. HIGH to LOW propagation delay (An to Bn);
V_{CC(A)}=2.5V

Figure 9-3 Typical propagation delay versus load capacitance; T_{amb}=25°C

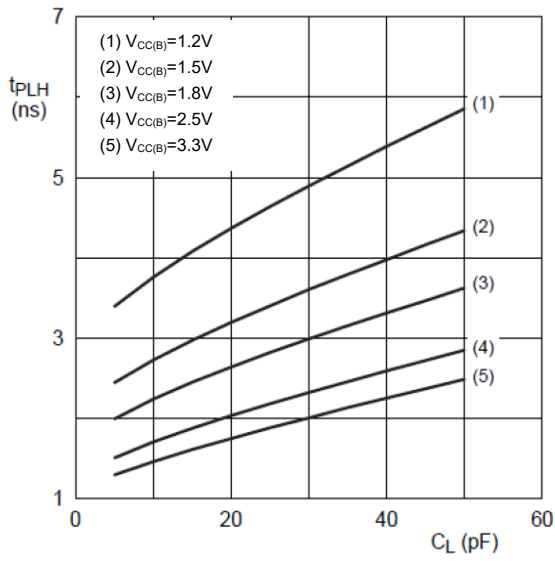

a. LOW to HIGH propagation delay (An to Bn);
 $V_{CC(A)}=3.3V$

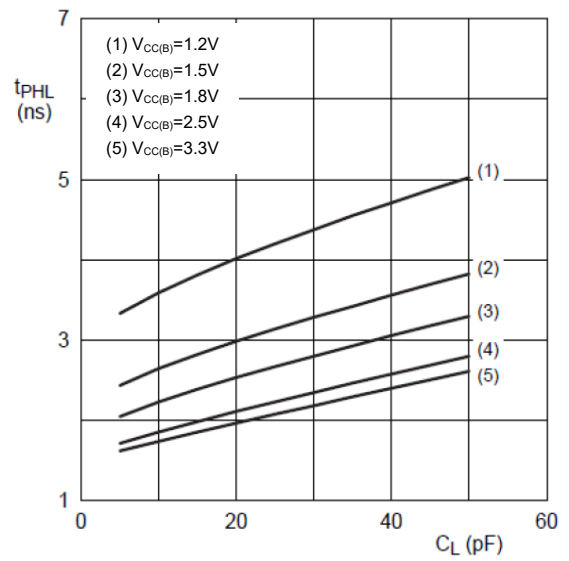

b. HIGH to LOW propagation delay (An to Bn);
 $V_{CC(A)}=3.3V$

Figure 9-4 Typical propagation delay versus load capacitance; $T_{amb}=25^{\circ}C$

10 Mechanical Information

10.1 TSSOP24 Mechanical Information

10.1.1 TSSOP24 Outline Dimensions

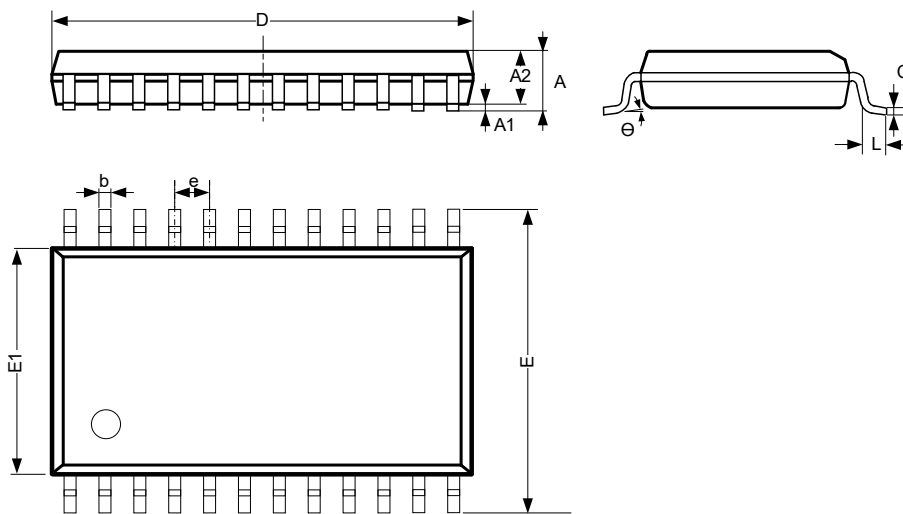

SYMBOL	Dimensions In Millimeters		
	Min.	Typ.	Max.
A	-	-	1.20
A1	0.05	-	0.15
A2	0.80	-	1.05
b	0.19	-	0.30
c	0.09	-	0.20
D	7.70	-	7.90
E	6.20	-	6.60
E1	4.30	-	4.50
e	0.65 BSC		
L	0.45	-	0.75
θ	0°	-	8°
Unit: mm			

10.2 QFN5.5x3.5-24L Mechanical Information

10.2.1 QFN5.5x3.5-24L Outline Dimensions

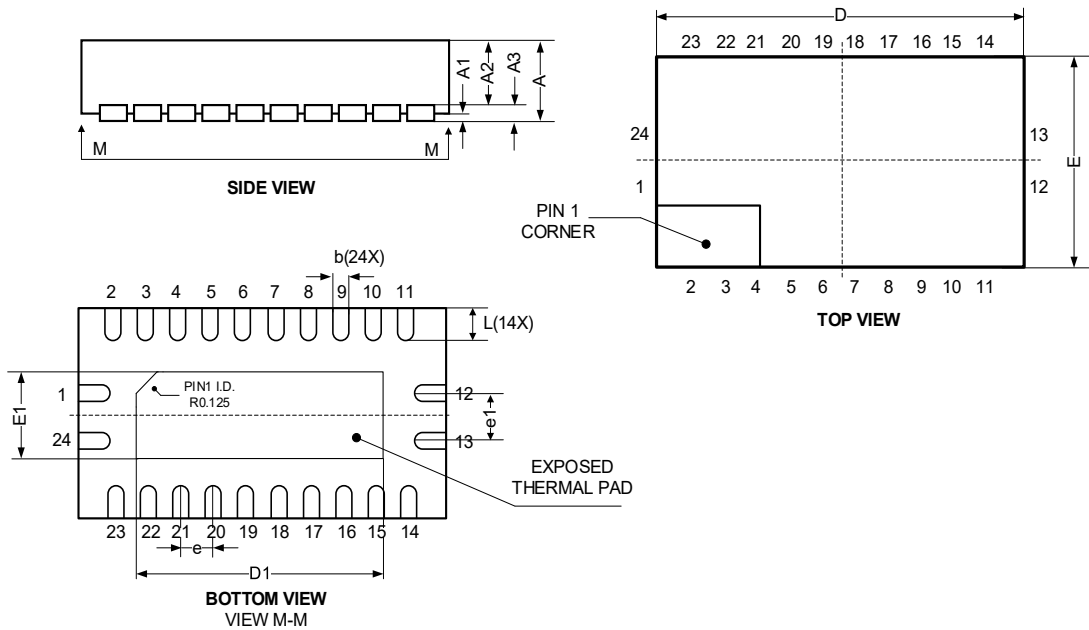

SYMBOL	Dimensions In Millimeters		
	Min.	Typ.	Max.
A	0.80	-	1.00
A1	0.00	-	0.05
A2	0.60	-	0.70
A3	-	0.20	-
D	5.40	-	5.60
E	3.40	-	3.60
e	0.50 BSC		
e1	-	1.50	-
b	0.18	-	0.30
L	0.30	-	0.50
D1	3.95	-	4.25
E1	1.95	-	2.25
Unit: mm			

11 Notes and Revision History

11.1 Associated Product Family and Others

To view other products of the same type or IC products of other types, click the official website of JSCJ -- <https://www.jscj-elec.com> for more details.

11.2 Notes

Electrostatic Discharge Caution



This IC may be damaged by ESD. Relevant personnel shall comply with correct installation and use specifications to avoid ESD damage to the IC. If appropriate measures are not taken to prevent ESD damage, the hazards caused by ESD include but are not limited to degradation of integrated circuit performance or complete damage of integrated circuit. For some precision integrated circuits, a very small parameter change may cause the whole device to be inconsistent with its published specifications.

DISCLAIMER

IMPORTANT NOTICE, PLEASE READ CAREFULLY

The information in this data sheet is intended to describe the operation and characteristics of our products. JSCJ has the right to make any modification, enhancement, improvement, correction or other changes to any content in this data sheet, including but not limited to specification parameters, circuit design and application information, without prior notice.

Any person who purchases or uses JSCJ products for design shall: 1. Select products suitable for circuit application and design; 2. Design, verify and test the rationality of circuit design; 3. Procedures to ensure that the design complies with relevant laws and regulations and the requirements of such laws and regulations. JSCJ makes no warranty or representation as to the accuracy or completeness of the information contained in this data sheet and assumes no responsibility for the application or use of any of the products described in this data sheet.

Without the written consent of JSCJ, this product shall not be used in occasions requiring high quality or high reliability, including but not limited to the following occasions: medical equipment, military facilities and aerospace. JSCJ shall not be responsible for casualties or property losses caused by abnormal use or application of this product.

Official Website: www.jscj-elec.com

Copyright © JIANGSU CHANGJING ELECTRONICS TECHNOLOGY CO., LTD