

Dual 4-channel Analog Multiplexer/Demultiplexer

CJ74HC/HCT4052 Logic

1 Introduction

The CJ74HC/HCT4052 is a dual single-pole quad-throw analog switch (2xSP4T) suitable for use in analog or digital 4:1 multiplexer/demultiplexer applications. Each switch features four independent inputs/outputs (nY0, nY1, nY2 and nY3) and a common input/output (nZ). A digital enable input (/E) and two digital select inputs (S0 and S1) are common to both switches. When /E is HIGH, the switches are turned off. Inputs include clamp diodes. This enables the use of current limiting resistors to interface inputs to voltages in excess of V_{CC}.

2 Available Packages

PART NUMBER	PACKAGE
CJ74HC4052	SOP16
	SSOP16
	TSSOP16
CJ74HCT4052	SOP16
	SSOP16
	TSSOP16

Note: For all available packages, please refer to the part Orderable Information.

3 Features

- Wide analog input voltage range from -4.5V to +4.5V
- Low ON resistance:
 - 80Ω (typical) at V_{CC}-V_{EE}=4.5V
 - 70Ω (typical) at V_{CC}-V_{EE}=6.0V
 - 60Ω (typical) at V_{CC}-V_{EE}=9.0V
- Typical “break before make” built-in
- Input levels:
 - For CJ74HC4052: CMOS level
 - For CJ74HCT4052: TTL level
- Specified from -40°C to +125°C

4 Applications

- Analog multiplexing and demultiplexing
- Digital multiplexing and demultiplexing
- Signal gating

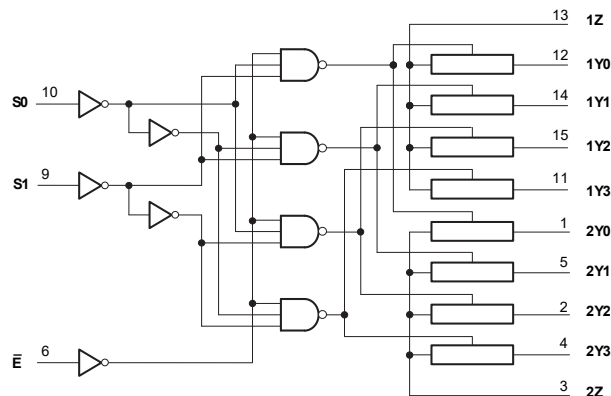

Logic diagram

5 Orderable Information

DEVICE	PACKAGE	OP TEMP	ECO PLAN	MSL	PACKING OPTION	SORT
CJ74HC4052AEN	SOP16	-40~125°C	RoHS & Green	Level 3 168HR	Tape and Reel 4000 Units / Reel	Active
CJ74HCT4052AEN	SOP16	-40~125°C	RoHS & Green	Level 3 168HR	Tape and Reel 4000 Units / Reel	Active
CJ74HC4052SEN	SSOP16	-40~125°C	RoHS & Green	Level 3 168HR	Tape and Reel 2500 Units / Reel	Active
CJ74HCT4052SEN	SSOP16	-40~125°C	RoHS & Green	Level 3 168HR	Tape and Reel 2500 Units / Reel	Active
CJ74HC4052BEN	TSSOP16	-40~125°C	RoHS & Green	Level 3 168HR	Tape and Reel 5000 Units / Reel	Active
CJ74HCT4052BEN	TSSOP16	-40~125°C	RoHS & Green	Level 3 168HR	Tape and Reel 5000 Units / Reel	Active

Note:

ECO PLAN: For the RoHS and Green certification standards of this product, please refer to the official report provided by JSCJ.

MSL: Moisture Sensitivity Level. Determined according to JEDEC industry standard classification.

SORT: Specifically defined as follows:

Active: Recommended for new products;

Customized: Products manufactured to meet the specific needs of customers;

Preview: The device has been released and has not been fully mass produced. The sample may or may not be available;

NoRD: It is not recommended to use the device for new design. The device is only produced for the needs of existing customers;

Obsolete: The device has been discontinued.

6 Pin Configuration and Marking Information

6.1 Pin Configuration

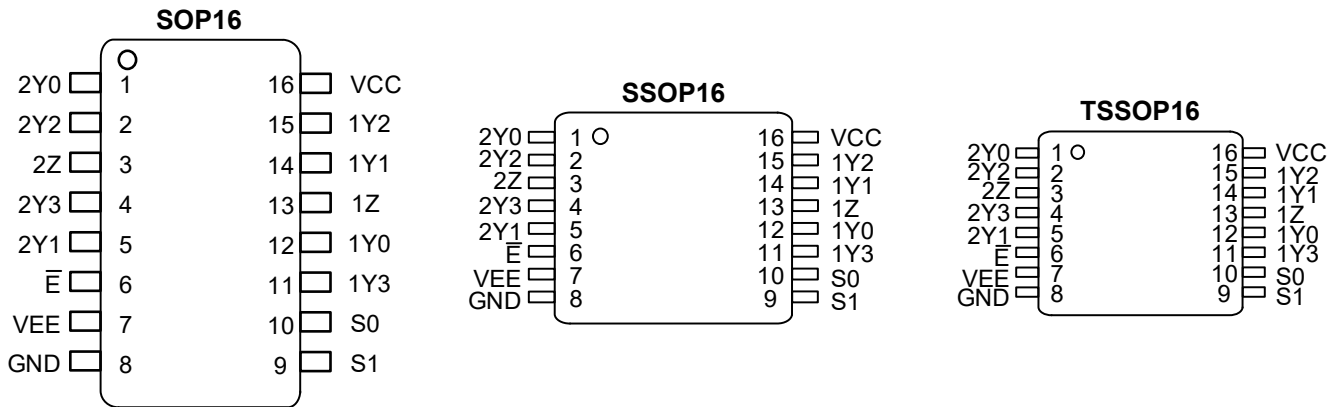

Figure 6-1 Pin configuration

6.2 Pin Function

PIN		I/O ⁽¹⁾	DESCRIPTION
No.	NAME		
1	2Y0	I/O	Independent input or output
2	2Y2	I/O	Independent input or output
3	2Z	I/O	Common input or output
4	2Y3	I/O	Independent input or output
5	2Y1	I/O	Independent input or output
6	\bar{E}	I	Enable input (active LOW)
7	VEE	P	Negative supply voltage
8	GND	G	Ground supply voltage
9	S1	I	Select logic input
10	S0	I	Select logic input
11	1Y3	I/O	Independent input or output
12	1Y0	I/O	Independent input or output
13	1Z	I/O	Common input or output
14	1Y1	I/O	Independent input or output
15	1Y2	I/O	Independent input or output
16	VCC	P	Positive supply voltage

(1) I-Input, O-Output, P-Power, G-Ground

6.3 Marking Information

6.3.1 CJ74HC4052

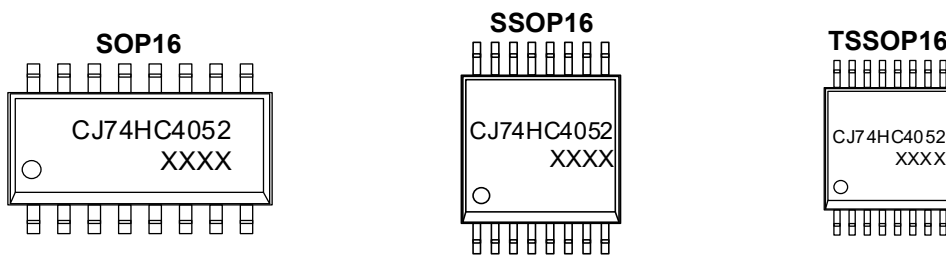

XXXX: Code, indicates weekly record information.

6.3.2 CJ74HCT4052

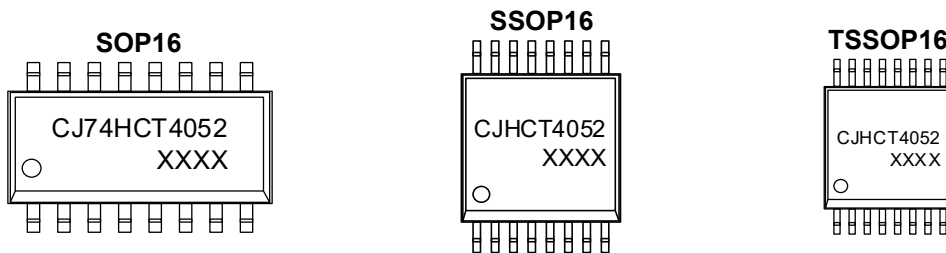

XXXX: Code, indicates weekly record information.

7 Specifications

7.1 Absolute Maximum Ratings

Voltages are referenced to $V_{EE}=GND$ (ground=0V), unless otherwise specified.

SYMBOL	PARAMETER	CONDITIONS	MIN.	MAX.	UNIT
V_{CC}	Supply voltage	- (1)	-0.5	+11	V
I_{IK}	Input clamping current	$V_I < -0.5\text{ V}$ or $V_I > V_{CC} + 0.5\text{ V}$	-	± 20	mA
I_{SK}	Switch clamping current	$V_{SW} < -0.5\text{ V}$ or $V_{SW} > V_{CC} + 0.5\text{ V}$	-	± 20	mA
I_{SW}	Switch current	$-0.5\text{ V} < V_{SW} < V_{CC} + 0.5\text{ V}$	-	± 25	mA
I_{EE}	Supply current	-	-	± 20	mA
I_{CC}	Supply current	-	-	50	mA
I_{GND}	Ground current	-	-	-50	mA
T_{stg}	Storage temperature	-	-65	+150	°C
P_{tot}	Total power dissipation	-	-	500	mW
P	Power dissipation	Per switch	-	100	mW
T_L	Soldering temperature	10s	-	260	°C

- (1) To avoid drawing V_{CC} current out of terminal nZ, when switch current flows into terminals nYn, the voltage drop across the bidirectional switch must not exceed 0.4 V. If the switch current flows into terminal nZ, no V_{CC} current will flow out of terminals nYn, and in this case there is no limit for the voltage drop across the switch, but the voltages at nYn and nZ may not exceed V_{CC} or V_{EE} .

7.2 Recommended Operating Conditions

SYMBOL	PARAMETER	CONDITIONS	MIN.	TYP.	MAX.	UNIT
CJ74HC4052						
V_{CC}	Supply voltage	$V_{CC}-GND$	3.0	5.0	9.0	V
		$V_{CC}-V_{EE}$	3.0	5.0	9.0	V
V_I	Input voltage	-	0	-	V_{CC}	V
V_{SW}	Switch voltage	-	V_{EE}	-	V_{CC}	V
T_{amb}	Ambient temperature	In free air	-40	-	+125	°C
$\Delta t/\Delta V$	Input transition rise and fall rate	$V_{CC}=4.5\text{ V}$	-	1.67	139	ns/V
		$V_{CC}=6.0\text{ V}$	-	-	83	ns/V
		$V_{CC}=9.0\text{ V}$	-	-	31	ns/V
CJ74HCT4052						
V_{CC}	Supply voltage	$V_{CC}-GND$	4.5	5.0	5.5	V
		$V_{CC}-V_{EE}$	3.0	5.0	9.0	V
V_I	Input voltage	-	0	-	V_{CC}	V
V_{SW}	Switch voltage	-	V_{EE}	-	V_{CC}	V
T_{amb}	Ambient temperature	In free air	-40	-	+125	°C
$\Delta t/\Delta V$	Input transition rise and fall rate	$V_{CC}=4.5\text{ V}$	-	1.67	139	ns/V
		$V_{CC}=6.0\text{ V}$	-	-	-	ns/V
		$V_{CC}=9.0\text{ V}$	-	-	-	ns/V

7.3 ESD Ratings

SYMBOL	ESD RATINGS		VALUE	UNIT
$V_{ESD-HBM}$	Electrostatic discharge	Human body model (HBM) ⁽¹⁾	±1500	V

(1) JEDEC document JEP155 states that 500-V HBM allows safe manufacturing with a standard ESD control process.

7.4 Electrical Characteristics
7.4.1 DC Characteristics 1

$T_{amb} = -40^{\circ}\text{C}$ to $+85^{\circ}\text{C}$, voltages are referenced to GND (ground=0V), unless otherwise specified.

SYMBOL	PARAMETER	CONDITIONS	MIN.	TYP.	MAX.	UNIT	
$R_{ON(peak)}$	ON resistance (peak)	$V_{is}=V_{CC}$ to V_{EE} ; $I_{SW}=1000\ \mu\text{A}$	$V_{CC}=4.5\text{V}; V_{EE}=0\text{V}$	-	100	225	Ω
			$V_C=6.0\text{V}; V_{EE}=0\text{V}$	-	90	200	Ω
			$V_{CC}=4.5\text{V}; V_{EE}=-4.5\text{V}$	-	70	165	Ω
$R_{ON(rail)}$	ON resistance (rail)	$V_{is}=V_{EE}$; $I_{SW}=1000\ \mu\text{A}$	$V_{CC}=4.5\text{V}; V_{EE}=0\text{V}$	-	80	175	Ω
			$V_{CC}=6.0\text{V}; V_{EE}=0\text{V}$	-	70	150	Ω
			$V_{CC}=4.5\text{V}; V_{EE}=-4.5\text{V}$	-	60	130	Ω
		$V_{is}=V_{CC}$; $I_{SW}=1000\ \mu\text{A}$	$V_{CC}=4.5\text{V}; V_{EE}=0\text{V}$	-	90	200	Ω
			$V_{CC}=6.0\text{V}; V_{EE}=0\text{V}$	-	80	175	Ω
			$V_{CC}=4.5\text{V}; V_{EE}=-4.5\text{V}$	-	65	150	Ω
ΔR_{ON}	ON resistance mismatch between channels	$V_{is}=V_{CC}$ to V_{EE}	$V_{CC}=4.5\text{V}; V_{EE}=0\text{V}$	-	9	-	Ω
			$V_{CC}=6.0\text{V}; V_{EE}=0\text{V}$	-	8	-	Ω
			$V_{CC}=4.5\text{V}; V_{EE}=-4.5\text{V}$	-	6	-	Ω

CJ74HC4052

V_{IH}	HIGH-level input voltage	$V_{CC}=4.5\text{V}$	3.15	-	-	V	
		$V_{CC}=6.0\text{V}$	4.2	-	-	V	
		$V_{CC}=9.0\text{V}$	6.3	-	-	V	
V_{IL}	LOW-level input voltage	$V_{CC}=4.5\text{V}$	-	-	1.35	V	
		$V_{CC}=6.0\text{V}$	-	-	1.8	V	
		$V_{CC}=9.0\text{V}$	-	-	2.7	V	
I_i	Input leakage current	$V_{EE}=0\text{V};$ $V_i=V_{CC}$ or GND	$V_{CC}=6.0\text{V}$	-	-	±1.0	μA
			$V_{CC}=9.0\text{V}$	-	-	±2.0	μA
$I_{S(OFF)}$	OFF-state leakage current	$V_{CC}=9.0\text{V}; V_{EE}=0\text{V};$ $V_i=V_{IH}$ or $V_{IL};$ $ V_{SW} =V_{CC}-V_{EE};$ See Figure 8-7	Per channel	-	-	±1.0	μA
			All channels	-	-	±2.0	μA
$I_{S(ON)}$	ON-state leakage current	$V_i=V_{IH}$ or $V_{IL}; V_{SW} =V_{CC}-V_{EE};$ $V_{CC}=9.0\text{V}; V_{EE}=0\text{V};$ See Figure 8-8	-	-	±2.0	μA	
I_{CC}	Supply current	$V_{EE}=0\text{V};$ $V_i=V_{CC}$ or GND; $V_{is}=V_{EE}$ or $V_{CC};$ $V_{os}=V_{CC}$ or V_{EE}	$V_{CC}=6.0\text{V}$	-	-	80.0	μA
			$V_{CC}=9.0\text{V}$	-	-	160.0	μA
C_i	Input capacitance	-	-	3.5	-	pF	
C_{SW}	Switch capacitance	Independent pins nYn	-	5	-	pF	

		Common pins nZ	-	12	-	pF	
CJ74HCT4052							
V_{IH}	HIGH-level input voltage	$V_{CC} = 4.5V$ to $5.5V$	2.0	-	-	V	
V_{IL}	LOW-level input voltage	$V_{CC} = 4.5V$ to $5.5V$	-	-	0.8	V	
I_i	Input leakage current	$V_i = V_{CC}$ or GND; $V_{CC} = 5.5V$; $V_{EE} = 0V$	-	-	± 1.0	μA	
$I_{S(OFF)}$	OFF-state leakage current	$V_{CC} = 9.0V$; $V_{EE} = 0V$; $V_i = V_{IH}$ or V_{IL} ; $ V_{SW} = V_{CC} - V_{EE}$; See Figure 8-7	Per channel	-	-	± 1.0	μA
			All channels	-	-	± 2.0	μA
$I_{S(ON)}$	ON-state leakage current	$V_i = V_{IH}$ or V_{IL} ; $ V_{SW} = V_{CC} - V_{EE}$; $V_{CC} = 9.0V$; $V_{EE} = 0V$; See Figure 8-8	-	-	± 2.0	μA	
I_{CC}	Supply current	$V_i = V_{CC}$ or GND; $V_{is} = V_{EE}$ or V_{CC} ; $V_{os} = V_{CC}$ or V_{EE}	$V_{CC} = 5.5V$; $V_{EE} = 0V$	-	-	80.0	μA
			$V_{CC} = 4.5V$; $V_{EE} = -4.5V$	-	-	160.0	μA
ΔI_{CC}	Additional supply current	Per input; $V_i = V_{CC} - 2.1V$; Other inputs at V_{CC} or GND; $V_{CC} = 4.5V$ to $5.5V$; $V_{EE} = 0V$	-	45	202.5	μA	
C_i	Input capacitance	-	-	3.5	-	pF	
C_{SW}	Switch capacitance	Independent pins nYn	-	5	-	pF	
		Common pins nZ	-	12	-	pF	

Note:

- (1) All typical values are measured at $T_{amb} = 25^\circ C$.
- (2) $V_i = V_{IH}$ or V_{IL} ; for test circuit see Figure 8-5.
- (3) V_{is} is the input voltage at a nYn or nZ terminal, whichever is assigned as an input.
- (4) V_{os} is the output voltage at a nYn or nZ terminal, whichever is assigned as an output.

7.4.2 DC Characteristics 2
 $T_{amb} = -40^\circ C$ to $+125^\circ C$, voltages are referenced to GND (ground=0V), unless otherwise specified.

SYMBOL	PARAMETER	CONDITIONS	MIN.	TYP.	MAX.	UNIT	
$R_{ON(peak)}$	ON resistance (peak)	$V_{is} = V_{CC}$ to V_{EE} ; $I_{SW} = 1000 \mu A$	$V_{CC} = 4.5V$; $V_{EE} = 0V$	-	-	270	Ω
			$V_C = 6.0V$; $V_{EE} = 0V$	-	-	240	Ω
			$V_{CC} = 4.5V$; $V_{EE} = -4.5V$	-	-	195	Ω
$R_{ON(rail)}$	ON resistance (rail)	$V_{is} = V_{EE}$; $I_{SW} = 1000 \mu A$	$V_{CC} = 4.5V$; $V_{EE} = 0V$	-	-	210	Ω
			$V_{CC} = 6.0V$; $V_{EE} = 0V$	-	-	180	Ω
			$V_{CC} = 4.5V$; $V_{EE} = -4.5V$	-	-	160	Ω
		$V_{is} = V_{CC}$; $I_{SW} = 1000 \mu A$	$V_{CC} = 4.5V$; $V_{EE} = 0V$	-	-	240	Ω
			$V_{CC} = 6.0V$; $V_{EE} = 0V$	-	-	210	Ω
			$V_{CC} = 4.5V$; $V_{EE} = -4.5V$	-	-	180	Ω
CJ74HC4052							
V_{IH}	HIGH-level input voltage	$V_{CC} = 4.5V$	3.15	-	-	V	
		$V_{CC} = 6.0V$	4.2	-	-	V	
		$V_{CC} = 9.0V$	6.3	-	-	V	

V _{IL}	LOW-level input voltage	V _{CC} =4.5V		-	-	1.35	V
		V _{CC} =6.0V		-	-	1.8	V
		V _{CC} =9.0V		-	-	2.7	V
I _I	Input leakage current	V _{EE} =0V; V _I =V _{CC} or GND	V _{CC} =6.0V	-	-	±1.0	uA
			V _{CC} =9.0V	-	-	±2.0	uA
I _{S(OFF)}	OFF-state leakage current	V _{CC} =9.0V; V _{EE} =0V; V _I =V _{IH} or V _{IL} ; V _{SW} =V _{CC} - V _{EE} ; See Figure 8-7	Per channel	-	-	±1.0	uA
			All channels	-	-	±2.0	uA
I _{S(ON)}	ON-state leakage current	V _I =V _{IH} or V _{IL} ; V _{SW} =V _{CC} - V _{EE} ; V _{CC} =9.0V; V _{EE} =0V; See Figure 8-8		-	-	±2.0	uA
I _{CC}	Supply current	V _{EE} =0V; V _I =V _{CC} or GND; V _{is} =V _{EE} or V _{CC} ; V _{os} =V _{CC} or V _{EE}	V _{CC} =6.0V	-	-	160.0	uA
			V _{CC} =9.0V	-	-	320.0	uA
CJ74HCT4052							
V _{IH}	HIGH-level input voltage	V _{CC} = 4.5 V to 5.5 V		2.0	-	-	V
V _{IL}	LOW-level input voltage	V _{CC} = 4.5 V to 5.5 V		-	-	0.8	V
I _I	Input leakage current	V _I = V _{CC} or GND; V _{CC} = 5.5 V; V _{EE} = 0 V		-	-	±1.0	uA
I _{S(OFF)}	OFF-state leakage current	V _{CC} =9.0V; V _{EE} =0V; V _I =V _{IH} or V _{IL} ; V _{SW} =V _{CC} - V _{EE} ; See Figure 8-7	Per channel	-	-	±1.0	uA
			All channels	-	-	±2.0	uA
I _{S(ON)}	ON-state leakage current	V _I =V _{IH} or V _{IL} ; V _{SW} =V _{CC} - V _{EE} ; V _{CC} =9.0V; V _{EE} =0V; See Figure 8-8		-	-	±2.0	uA
I _{CC}	Supply current	V _I = V _{CC} or GND; V _{is} = V _{EE} or V _{CC} ; V _{os} = V _{CC} or V _{EE}	V _{CC} = 5.5V; V _{EE} = 0 V	-	-	160.0	uA
			V _{CC} = 4.5V; V _{EE} = -4.5V	-	-	320.0	uA
ΔI _{CC}	Additional supply current	Per input; V _I = V _{CC} - 2.1V; Other inputs at V _{CC} or GND; V _{CC} = 4.5 V to 5.5 V; V _{EE} = 0 V		-	-	220.5	uA

Note:

- (1) All typical values are measured at T_{amb}= 25°C.
- (2) V_I= V_{IH} or V_{IL}; for test circuit see Figure 8-5.
- (3) V_{is} is the input voltage at a nYn or nZ terminal, whichever is assigned as an input.
- (4) V_{os} is the output voltage at a nYn or nZ terminal, whichever is assigned as an output.

7.4.3 AC Characteristics 1

T_{amb}=-40°C to +85°C, GND=0V; t_r = t_f = 6ns; C_L=50pF; unless otherwise specified.

SYMBOL	PARAMETER	CONDITIONS	MIN.	TYP.	MAX.	UNIT	
CJ74HC4052							
t _{pd}	Propagation delay	V _{is} to V _{os} ; R _L =∞ Ω; See Figure 8-9	V _{CC} =4.5V; V _{EE} =0V	-	5	15	ns
			V _{CC} =6.0V; V _{EE} =0V	-	4	13	ns
			V _{CC} =4.5V; V _{EE} =-4.5V	-	4	10	ns
t _{on}	Turn-on time	\bar{E} , Sn to V _{os} ; R _L =∞ Ω; See Figure 8-10	V _{CC} =4.5V; V _{EE} =0V	-	38	81	ns
			V _{CC} =5.0V; V _{EE} =0V; C _L =15pF	-	28	-	ns
			V _{CC} =6.0V; V _{EE} =0V	-	30	69	ns
			V _{CC} =4.5V; V _{EE} =-4.5V	-	26	58	ns
t _{off}	Turn-off time	\bar{E} , Sn to V _{os} ; R _L =1kΩ; See Figure 8-10	V _{CC} =4.5V; V _{EE} =0V	-	27	63	ns
			V _{CC} =5.0V; V _{EE} =0V; C _L =15pF	-	21	-	ns
			V _{CC} =6.0V; V _{EE} =0V	-	22	54	ns
			V _{CC} =4.5V; V _{EE} =-4.5V	-	22	48	ns
C _{PD}	Power dissipation capacitance	Per switch; V _I =GND to V _{CC}	-	57	-	pF	
CJ74HCT4052							
t _{pd}	Propagation delay	V _{is} to V _{os} ; R _L =∞ Ω; See Figure 8-9	V _{CC} = 4.5 V; V _{EE} = 0 V	-	5	15	ns
			V _{CC} = 4.5 V; V _{EE} = -4.5 V	-	4	10	ns
t _{on}	Turn-on time	\bar{E} , Sn to V _{os} ; R _L =∞ Ω; See Figure 8-10	V _{CC} = 4.5 V; V _{EE} = 0 V	-	41	88	ns
			V _{CC} = 5.0 V; V _{EE} = 0V; C _L =15pF	-	18	-	ns
			V _{CC} = 4.5 V; V _{EE} = -4.5 V	-	28	60	ns
t _{off}	Turn-off time	\bar{E} , Sn to V _{os} ; R _L =1kΩ; See Figure 8-10	V _{CC} = 4.5 V; V _{EE} = 0 V	-	26	63	ns
			V _{CC} = 5.0 V; V _{EE} = 0V; C _L =15pF	-	13	-	ns
			V _{CC} = 4.5 V; V _{EE} = -4.5 V	-	21	48	ns
C _{PD}	Power dissipation capacitance	Per switch; V _I = GND to V _{CC} -1.5V	-	57	-	pF	

Note:

- (1) All typical values are measured at T_{amb}= 25°C.
- (2) t_{pd} is the same as t_{PHL} and t_{PLH}.
- (3) t_{on} is the same as t_{PZH} and t_{PZL}.
- (4) t_{off} is the same as t_{PHZ} and t_{PLZ}.
- (5) C_{PD} is used to determine the dynamic power dissipation (P_D in uW).
 $P_D = C_{PD} \times V_{CC}^2 \times f_i \times N + \sum \{(C_L + C_{SW}) \times V_{CC}^2 \times f_o\}$ where:
 f_i = input frequency in MHz; f_o = output frequency in MHz;
 N = number of inputs switching; $\sum \{(C_L + C_{SW}) \times V_{CC}^2 \times f_o\}$ = sum of outputs;
 C_L = output load capacitance in pF; C_{SW} = switch capacitance in pF; V_{CC} = supply voltage in V.
- (6) For test circuit see Figure 8-11.
- (7) V_{is} is the input voltage at a nYn or nZ terminal, whichever is assigned as an input.
- (8) V_{os} is the output voltage at a nYn or nZ terminal, whichever is assigned as an output.

7.4.4 AC Characteristics 2

T_{amb}=-40°C to +125°C, GND=0V; t_r = t_f = 6ns; C_L=50pF; unless otherwise specified.

SYMBOL	PARAMETER	CONDITIONS	MIN.	TYP.	MAX.	UNIT	
CJ74HC4052							
t _{pd}	Propagation delay	V _{is} to V _{os} ; R _L =∞ Ω; See Figure 8-9	V _{CC} =4.5V; V _{EE} =0V	-	-	18	ns
			V _{CC} =6.0V; V _{EE} =0V	-	-	15	ns
			V _{CC} =4.5V; V _{EE} =-4.5V	-	-	12	ns
t _{on}	Turn-on time	\bar{E} , Sn to V _{os} ; R _L =∞ Ω; See Figure 8-10	V _{CC} =4.5V; V _{EE} =0V	-	-	98	ns
			V _{CC} =6.0V; V _{EE} =0V	-	-	83	ns
			V _{CC} =4.5V; V _{EE} =-4.5V	-	-	69	ns
t _{off}	Turn-off time	\bar{E} , Sn to V _{os} ; R _L =1kΩ; See Figure 8-10	V _{CC} =4.5V; V _{EE} =0V	-	-	75	ns
			V _{CC} =6.0V; V _{EE} =0V	-	-	64	ns
			V _{CC} =4.5V; V _{EE} =-4.5V	-	-	57	ns
CJ74HCT4052							
t _{pd}	Propagation delay	V _{is} to V _{os} ; R _L =∞ Ω; See Figure 8-9	V _{CC} =4.5V; V _{EE} =0V	-	-	18	ns
			V _{CC} =4.5V; V _{EE} =-4.5V	-	-	12	ns
t _{on}	Turn-on time	\bar{E} , Sn to V _{os} ; R _L =1kΩ; See Figure 8-10	V _{CC} =4.5V; V _{EE} =0V	-	-	105	ns
			V _{CC} =4.5V; V _{EE} =-4.5V	-	-	72	ns
t _{off}	Turn-off time	\bar{E} , Sn to V _{os} ; R _L =1kΩ; See Figure 8-10	V _{CC} =4.5V; V _{EE} =0V	-	-	75	ns
			V _{CC} =4.5V; V _{EE} =-4.5V	-	-	57	ns

Note:

- (1) All typical values are measured at T_{amb}= 25°C.
- (2) t_{pd} is the same as t_{PHL} and t_{PLH}.
- (3) t_{on} is the same as t_{PZH} and t_{PZL}.
- (4) t_{off} is the same as t_{PHZ} and t_{PLZ}.
- (5) For test circuit see Figure 8-11.
- (6) V_{is} is the input voltage at a nYn or nZ terminal, whichever is assigned as an input.
- (7) V_{os} is the output voltage at a nYn or nZ terminal, whichever is assigned as an output.

7.4.5 AC Characteristics 3

T_{amb}=25°C, GND=0V; C_L=50 pF; recommended conditions and typical values.

SYMBOL	PARAMETER	CONDITIONS	MIN.	TYP.	MAX.	UNIT	
d _{sin}	Sine-wave distortion	f _i =1 kHz; R _L =10 kΩ; See Figure 8-12	V _{is} =4.0V (p-p); V _{CC} =2.25V; V _{EE} =-2.25V	-	0.04	-	%
			V _{is} =8.0V (p-p); V _{CC} =4.5V; V _{EE} =-4.5V	-	0.02	-	%
		f _i =10 kHz; R _L =10 kΩ; See Figure 8-12	V _{is} =4.0V (p-p); V _{CC} =2.25V; V _{EE} =-2.25V	-	0.12	-	%
			V _{is} =8.0V (p-p); V _{CC} =4.5V; V _{EE} =-4.5V	-	0.06	-	%
α _{iso}	Isolation (OFF-state)	R _L = 600 Ω; f _i = 1 MHz; See Figure 8-13	V _{CC} =2.25V; V _{EE} =-2.25V	-	-50	-	dB
			V _{CC} =4.5V; V _{EE} =-4.5V	-	-50	-	dB
Xtalk	Crosstalk	Between two switches/multiplexers; R _L =600 Ω; f _i =1 MHz; See Figure 8-14	V _{CC} =2.25V; V _{EE} =-2.25V	-	-60	-	dB
			V _{CC} =4.5V; V _{EE} =-4.5V	-	-60	-	dB
V _{ct}	Crosstalk voltage	Peak-to-peak value; Between control and any switch; R _L = 600 Ω; f _i = 1MHz; E or Sn square wave between V _{CC} and GND; t _r = t _f = 6 ns; See Figure 8-15	V _{CC} =4.5V; V _{EE} =0V	-	110	-	mV
			V _{CC} =4.5V; V _{EE} =-4.5V	-	220	-	mV
f _(-3dB)	-3dB frequency response	R _L =50 Ω; See Figure 8-16	V _{CC} =2.25V; V _{EE} =-2.25V	-	170	-	MHz
			V _{CC} =4.5V; V _{EE} =-4.5V	-	180	-	MHz

Note:

- (1) Adjust input voltage V_{is} to 0 dBm level (0 dBm = 1 mW into 600 Ω).
- (2) Adjust input voltage V_{is} to 0 dBm level at V_{os} for 1 MHz (0 dBm = 1 mW into 50 Ω).
- (3) V_{is} is the input voltage at a nYn or nZ terminal, whichever is assigned as an input.
- (4) V_{os} is the output voltage at a nYn or nZ terminal, whichever is assigned as an output.

8 Detailed Description

8.1 Overview

The CJ74HC/HCT4052 is a dual single-pole quad-throw analog switch (2xSP4T) suitable for use in analog or digital 4:1 multiplexer/demultiplexer applications. Each switch features four independent inputs/outputs (nY0, nY1, nY2 and nY3) and a common input/output (nZ). A digital enable input (/E) and two digital select inputs (S0 and S1) are common to both switches. When /E is HIGH, the switches are turned off. Inputs include clamp diodes. This enables the use of current limiting resistors to interface inputs to voltages in excess of V_{CC}.

8.2 Functional Block Diagram

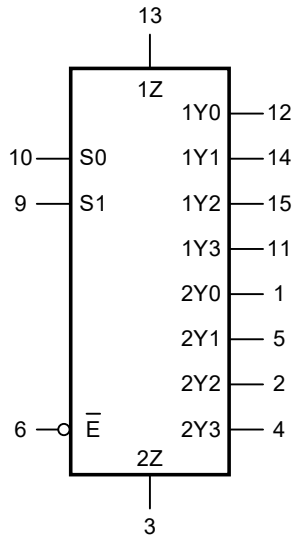

Figure 8-1 Logic symbol

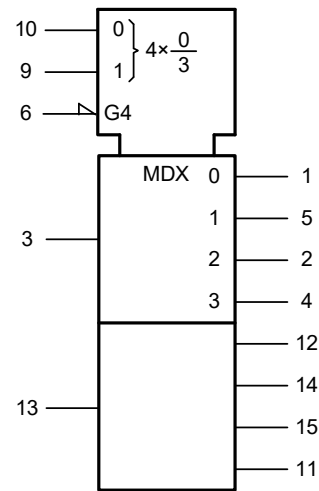

Figure 8-2 IEC logic symbol

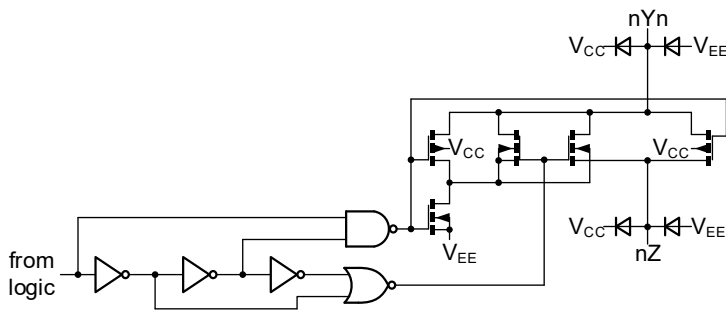

Figure 8-3 Schematic diagram (one switch)

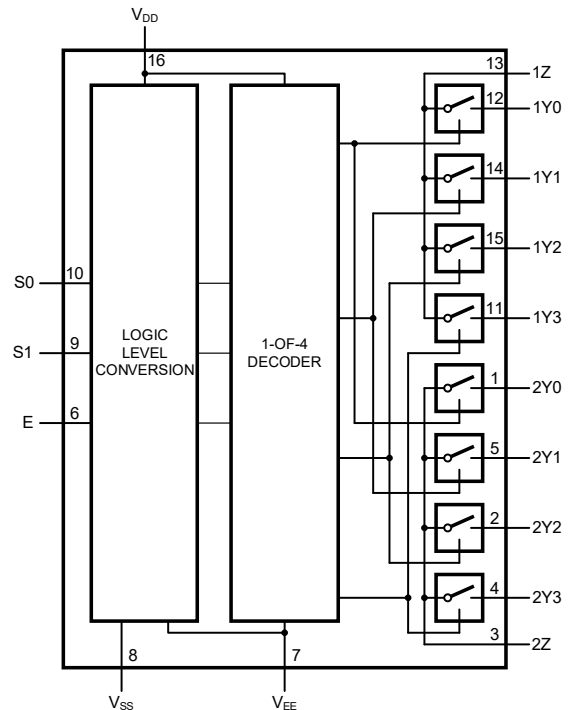

Figure 8-4 Functional diagram

8.3 Function Table⁽¹⁾

INPUT			CHANNEL ON
\bar{E}	S1	S0	
L	L	L	nY0 and nZ
L	L	H	nY1 and nZ
L	H	L	nY2 and nZ
L	H	H	nY3 and nZ
H	X	X	None

(1) H=HIGH voltage level; L=LOW voltage level; X=don't care.

8.4 Testing Circuit

8.4.1 DC Testing Circuit 1

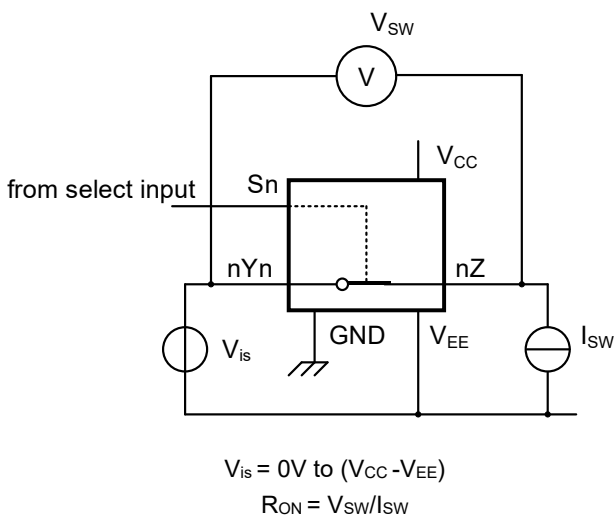

Figure 8-5 Test circuit for measuring R_{ON}

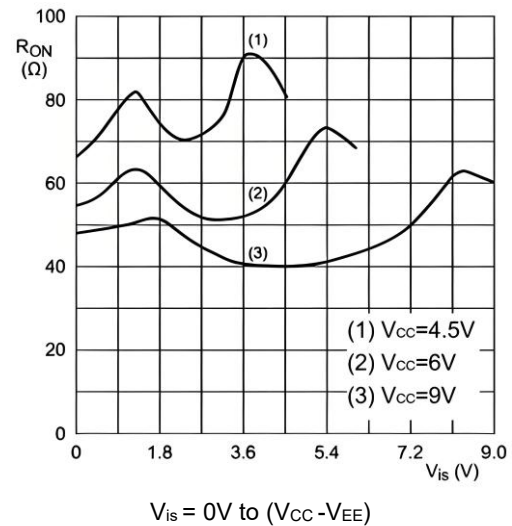

Figure 8-6 Typical R_{ON} as a function of input voltage V_{is}

8.4.2 DC Testing Circuit 2

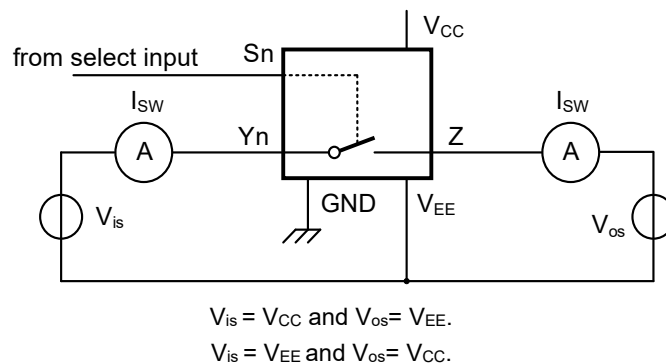

Figure 8-7 Test circuit for measuring OFF-state current

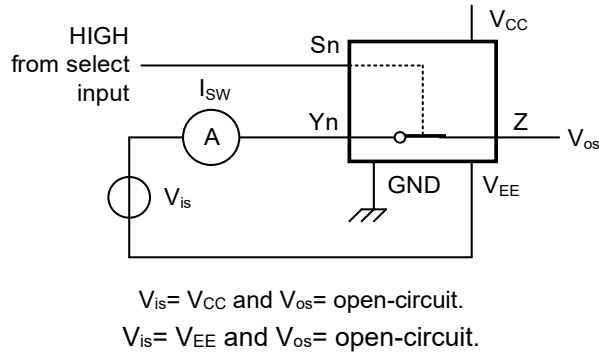
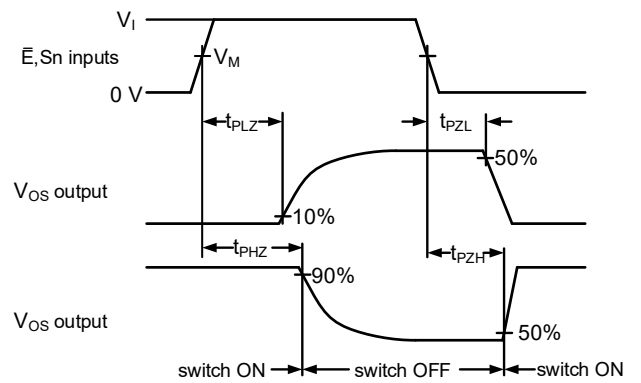
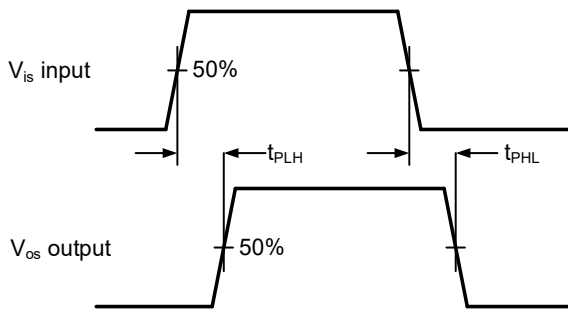

Figure 8-8 Test circuit for measuring ON-state current

8.4.3 AC Testing Waveforms



For CJ74HC4052: $V_M = 0.5 \times V_{CC}$.
 For CJ74HCT4052: $V_M = 1.3 \text{ V.}$

Figure 8-9 Input (V_{is}) to output (V_{os}) propagation delays

Figure 8-10 Turn-on and turn-off times

8.4.4 AC Testing Circuit 1

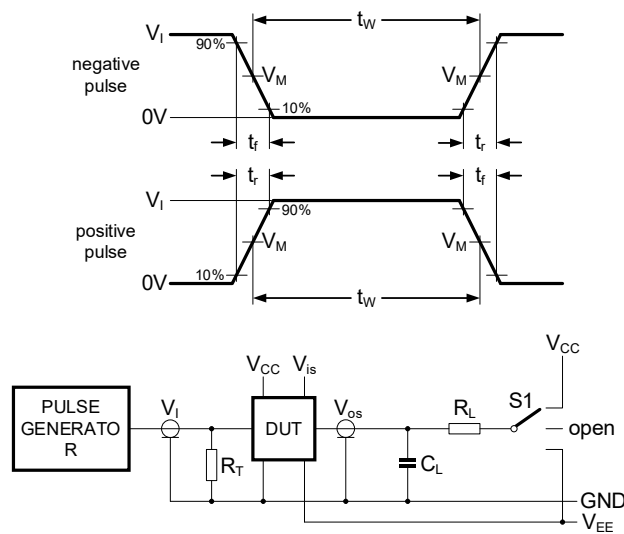

Figure 8-11 Test circuit for measuring switching times

Definitions for test circuit:

R_T = termination resistance should be equal to the output impedance Z_O of the pulse generator.

C_L = load capacitance including jig and probe capacitance.

R_L = load resistance. S1 = Test selection switch.

8.4.5 AC Testing Circuit 2

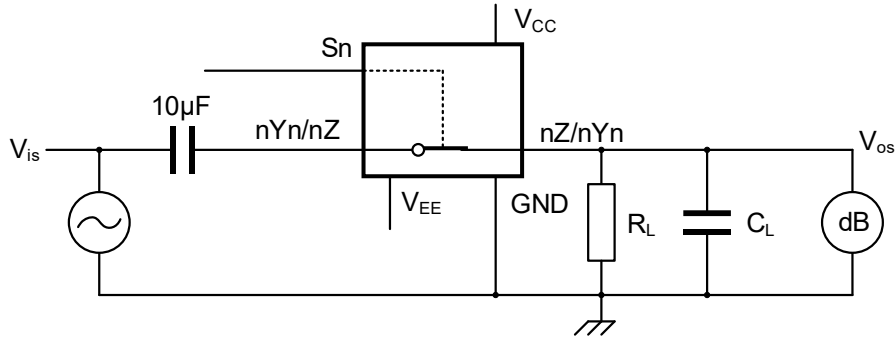
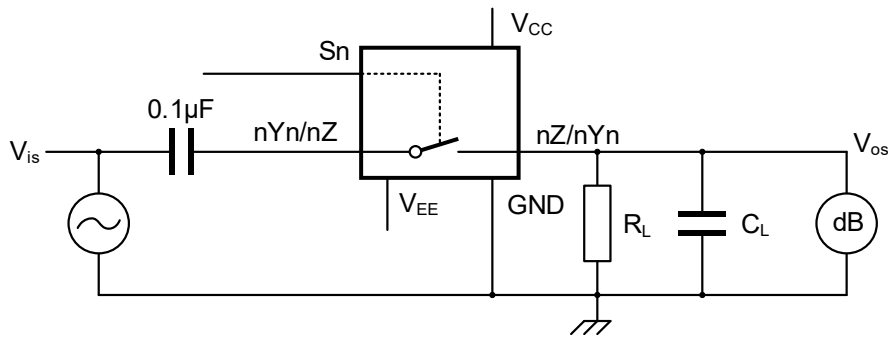
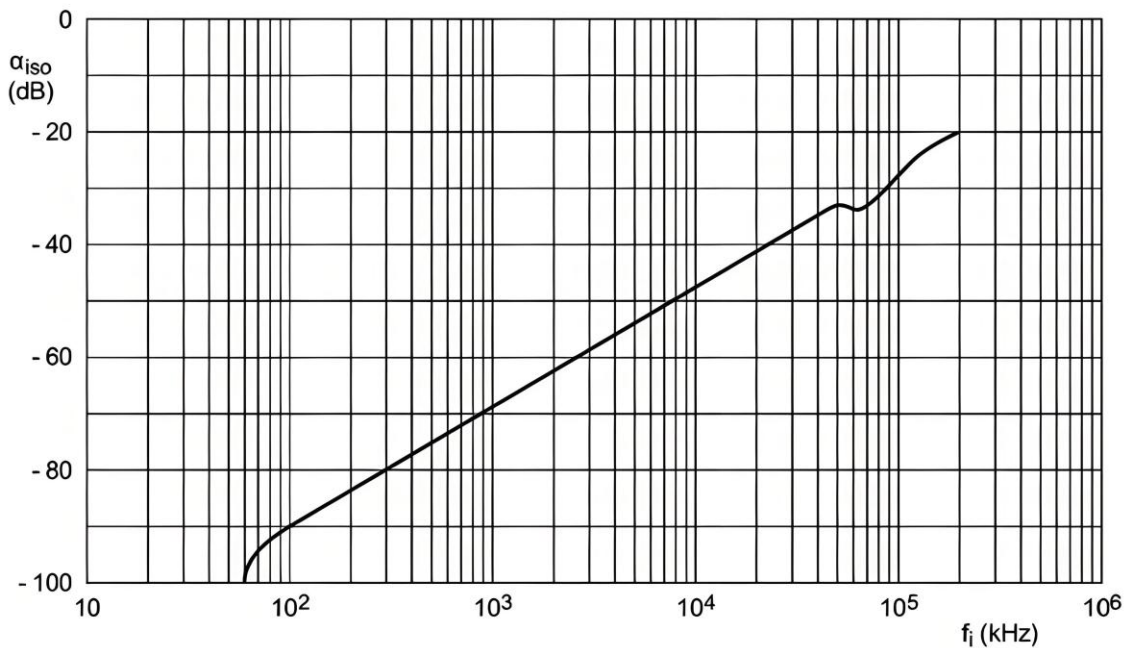

Figure 8-12 Test circuit for measuring sine-wave distortion



$V_{CC} = 4.5\text{ V}$; $GND = 0\text{ V}$; $V_{EE} = -4.5\text{ V}$; $R_L = 600\ \Omega$; $R_S = 1\text{ k}\Omega$.

a. Test circuit



b. Isolation (OFF-state) as a function of frequency

Figure 8-13 Test circuit for measuring isolation (OFF-state)

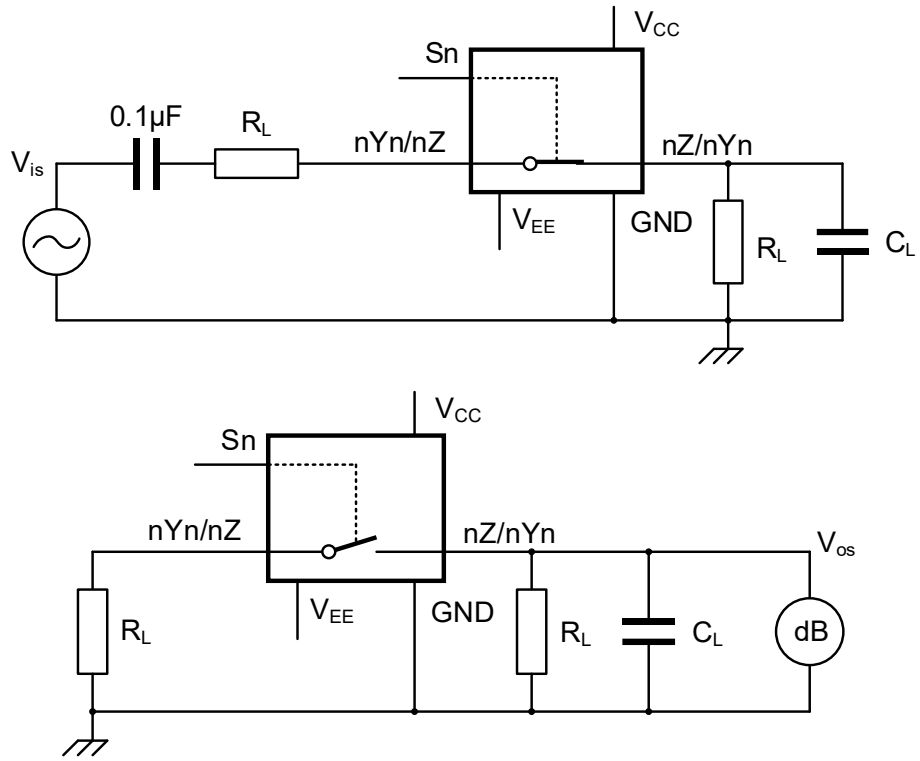

Figure 8-14 Test circuits for measuring crosstalk between any two switches/multiplexers

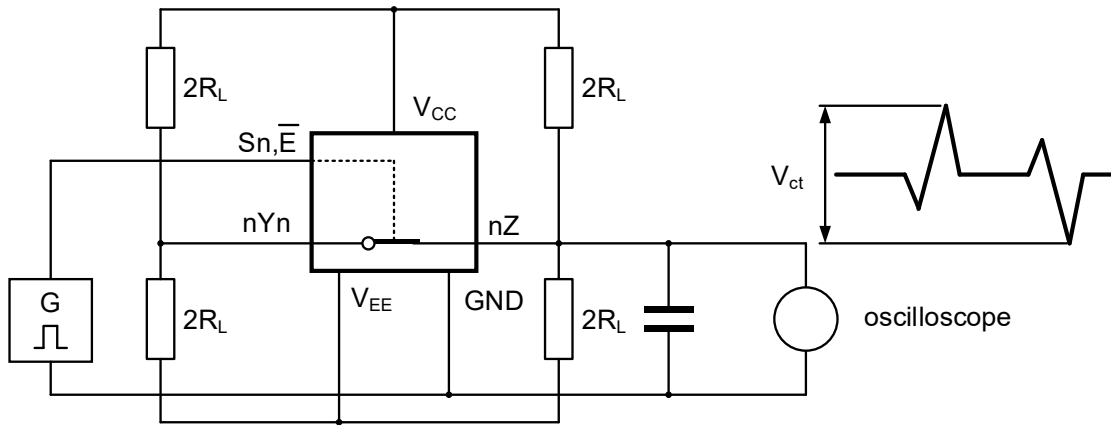
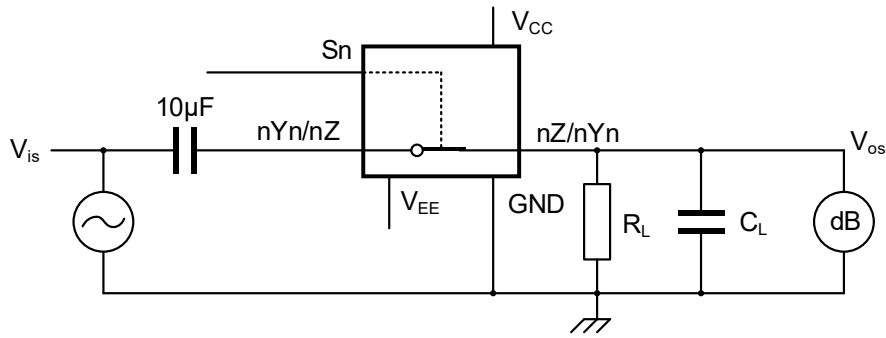
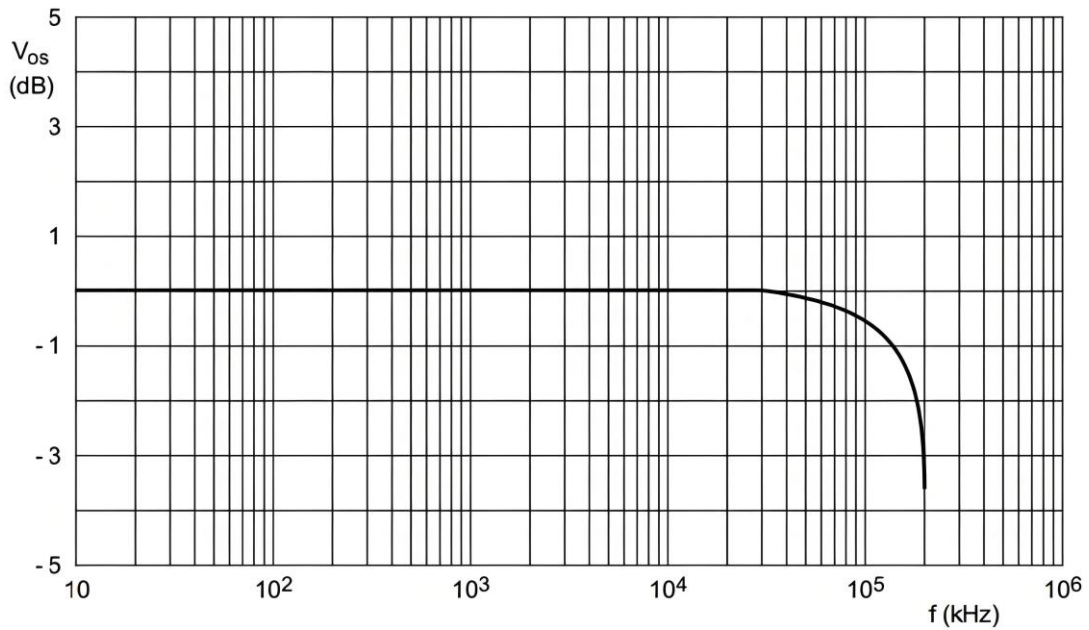

Figure 8-15 Test circuit for measuring crosstalk between control input and any switch



$V_{CC} = 4.5\text{ V}; GND = 0\text{ V}; V_{EE} = -4.5\text{ V}; R_L = 50\ \Omega; R_S = 1\text{ k}\Omega$

a. Test circuit



b. Typical frequency response

Figure 8-16 Test circuit for frequency response

8.4.6 Test Data

TEST	INPUT				LOAD		S1 POSITION
	V _I	V _{is}	t _r , t _f		C _L	R _L	
			at f _{max}	Other ⁽¹⁾			
t _{PHL} , t _{PLH}	(2)	Pulse	<2ns	6ns	50pF	1kΩ	Open
t _{PZH} , t _{PHZ}	(2)	V _{CC}	<2ns	6ns	50pF	1kΩ	V _{EE}
t _{PZL} , t _{PLZ}	(2)	V _{EE}	<2ns	6ns	50pF	1kΩ	V _{CC}

(1) t_r = t_f = 6 ns; when measuring f_{max}, there is no constraint to t_r and t_f with 50 % duty factor.

(2) V_I values:

For CJ74HC4052: V_I = V_{CC}.

For CJ74HCT4052: V_I = 3V.

9 Mechanical Information

9.1 SOP16 Mechanical Information

9.1.1 SOP16 Outline Dimensions

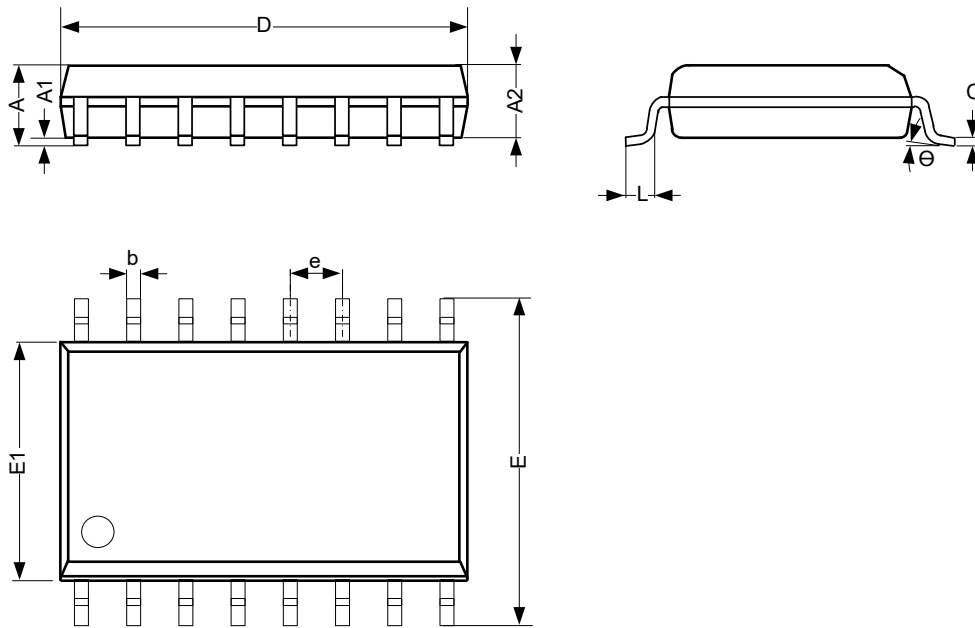

SYMBOL	Dimensions In Millimeters		
	Min.	Typ.	Max.
A	1.35	-	1.80
A1	0.10	-	0.25
A2	1.25	-	1.55
b	0.33	-	0.51
c	0.19	-	0.25
D	9.50	-	10.10
E	5.80	-	6.30
E1	3.70	-	4.10
e	1.27 BSC		
L	0.35	-	0.89
θ	0°	-	8°
Unit: mm			

9.2 SSOP16 Mechanical Information

9.2.1 SSOP16 Outline Dimensions

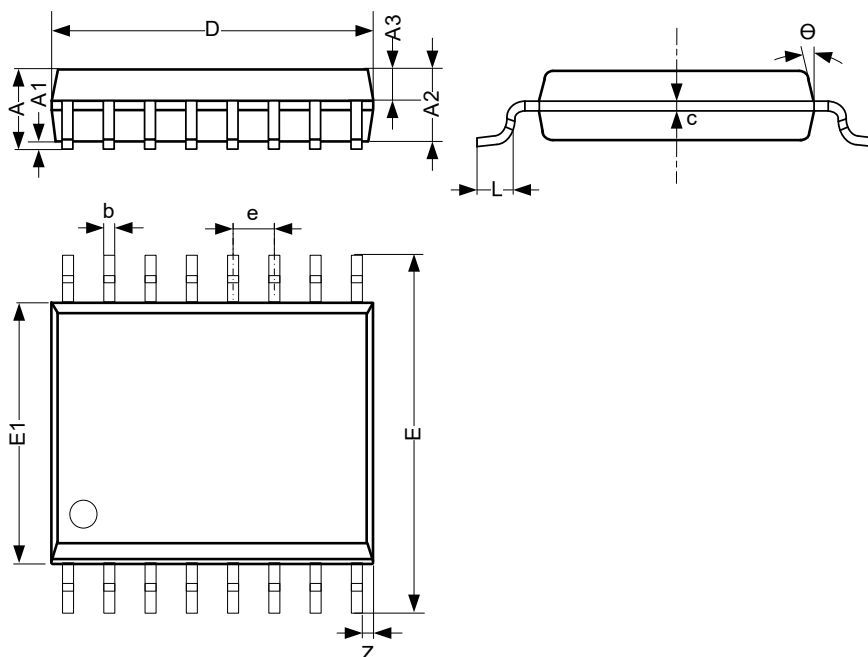

SYMBOL	Dimensions In Millimeters		
	Min.	Typ.	Max.
A	1.75	-	1.95
A1	0.05	-	0.15
A2	1.70	-	1.80
A3	-	0.80	-
b	-	0.30	-
c	-	0.15	-
D	6.15	-	6.25
E	7.65	-	7.95
E1	5.25	-	5.35
e	0.65 BSC		
L	0.60	-	0.80
Z	-	0.675	-
θ	0°	-	8°
Unit: mm			

9.3 TSSOP16 Mechanical Information

9.3.1 TSSOP16 Outline Dimensions

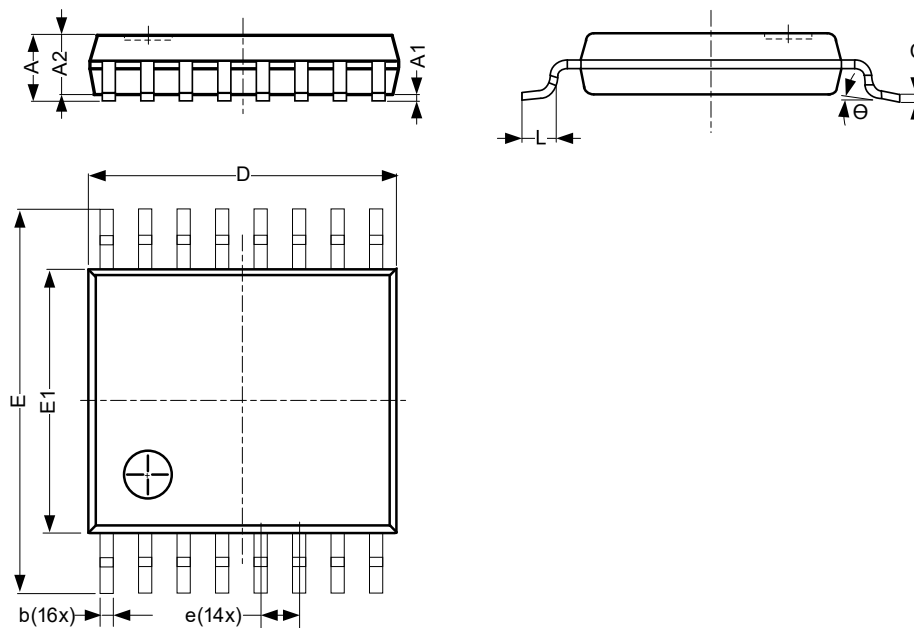

SYMBOL	Dimensions In Millimeters		
	Min.	Typ.	Max.
A	-	-	1.20
A1	0.05	-	0.15
A2	0.80	-	1.05
b	0.19	-	0.30
c	0.09	-	0.20
D	4.90	-	5.10
E	6.20	-	6.60
E1	4.30	-	4.50
e	0.65 BSC		
L	0.45	-	0.75
Θ	0°	-	8°
Unit: mm			

10 Notes and Revision History

10.1 Associated Product Family and Others

To view other products of the same type or IC products of other types, click the official website of JSCJ -- <https://www.jscj-elec.com> for more details.

10.2 Notes

Electrostatic Discharge Caution



This IC may be damaged by ESD. Relevant personnel shall comply with correct installation and use specifications to avoid ESD damage to the IC. If appropriate measures are not taken to prevent ESD damage, the hazards caused by ESD include but are not limited to degradation of integrated circuit performance or complete damage of integrated circuit. For some precision integrated circuits, a very small parameter change may cause the whole device to be inconsistent with its published specifications.

10.3 Revision History

July, 2025: rev - 1.1, Added 74HCT4052 and change marking information.

DISCLAIMER

IMPORTANT NOTICE, PLEASE READ CAREFULLY

The information in this data sheet is intended to describe the operation and characteristics of our products. JSCJ has the right to make any modification, enhancement, improvement, correction or other changes to any content in this data sheet, including but not limited to specification parameters, circuit design and application information, without prior notice.

Any person who purchases or uses JSCJ products for design shall: 1. Select products suitable for circuit application and design; 2. Design, verify and test the rationality of circuit design; 3. Procedures to ensure that the design complies with relevant laws and regulations and the requirements of such laws and regulations. JSCJ makes no warranty or representation as to the accuracy or completeness of the information contained in this data sheet and assumes no responsibility for the application or use of any of the products described in this data sheet.

Without the written consent of JSCJ, this product shall not be used in occasions requiring high quality or high reliability, including but not limited to the following occasions: medical equipment, military facilities and aerospace. JSCJ shall not be responsible for casualties or property losses caused by abnormal use or application of this product.

Official Website: www.jscj-elec.com

Copyright © JIANGSU CHANGJING ELECTRONICS TECHNOLOGY CO., LTD