



Quad Buffer/Line Driver: 3-state

# CJ74HC/HCT125 Logic

## 1 Introduction

The CJ74HC/HCT125 is a quad buffer/line driver with 3-state outputs controlled by the output enable inputs (/nOE). A HIGH on /nOE causes the outputs to assume a high-impedance OFF-state. Inputs include clamp diodes. This enables the use of current limiting resistors to interface inputs to voltages in excess of V<sub>cc</sub>.

## 2 Available Packages

PART NUMBER	PACKAGE
CJ74HC125	SOP14
	TSSOP14
CJ74HCT125	SOP14
	TSSOP14

**Note:** For all available packages, please refer to the part Orderable Information.

## 3 Features

- Input levels:
  - For CJ74HC125: CMOS level
  - For CJ74HCT125: TTL level
- Specified from -40°C to +125°C

## 4 Applications

- Enable digital signals

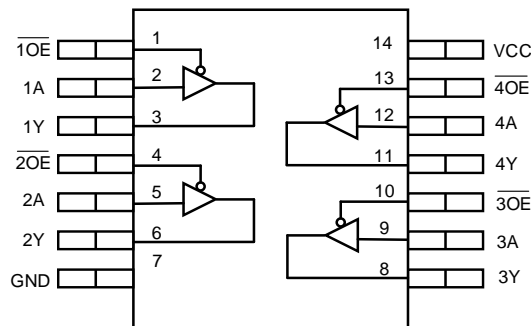

Functional pinout

**5 Orderable Information**

DEVICE	PACKAGE	OP TEMP	ECO PLAN	MSL	PACKING OPTION	SORT
CJ74HC125ADN	SOP14	-40~125°C	RoHS & Green	Level 3 168HR	Tape and Reel 4000 Units / Reel	Active
CJ74HCT125ADN	SOP14	-40~125°C	RoHS & Green	Level 3 168HR	Tape and Reel 4000 Units / Reel	Active
CJ74HC125BDN	TSSOP14	-40~125°C	RoHS & Green	Level 3 168HR	Tape and Reel 5000 Units / Reel	Active
CJ74HCT125BDN	TSSOP14	-40~125°C	RoHS & Green	Level 3 168HR	Tape and Reel 5000 Units / Reel	Active

**Note:**

**ECO PLAN:** For the RoHS and Green certification standards of this product, please refer to the official report provided by JSCJ.

**MSL:** Moisture Sensitivity Level. Determined according to JEDEC industry standard classification.

**SORT:** Specifically defined as follows:

Active: Recommended for new products;

Customized: Products manufactured to meet the specific needs of customers;

Preview: The device has been released and has not been fully mass produced. The sample may or may not be available;

NoRD: It is not recommended to use the device for new design. The device is only produced for the needs of existing customers;

Obsolete: The device has been discontinued.

## 6 Pin Configuration and Marking Information

### 6.1 Pin Configuration

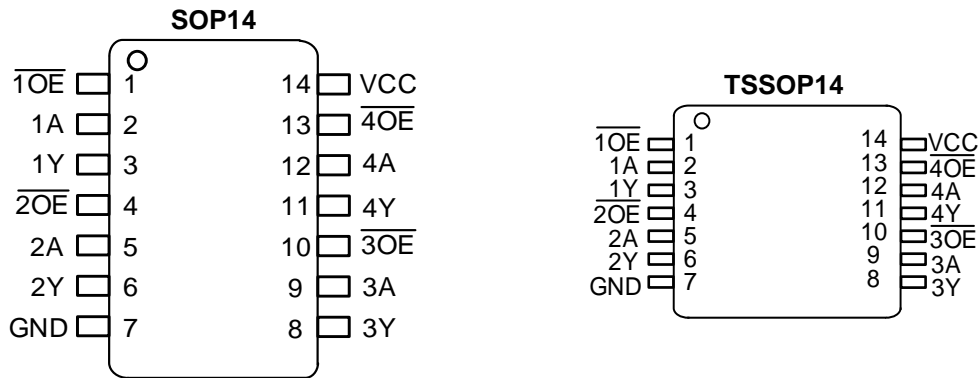

Figure 6-1 Pin configuration

### 6.2 Pin Function

PIN		I/O <sup>(1)</sup>	DESCRIPTION
No.	NAME		
1	$\overline{1OE}$	I	Output enable input (active LOW)
2	1A	I	Data input
3	1Y	O	Data output
4	$\overline{2OE}$	I	Output enable input (active LOW)
5	2A	I	Data input
6	2Y	O	Data output
7	GND	G	Ground (0V)
8	3Y	O	Data output
9	3A	I	Data input
10	$\overline{3OE}$	I	Output enable input (active LOW)
11	4Y	O	Data output
12	4A	I	Data input
13	$\overline{4OE}$	I	Output enable input (active LOW)
14	VCC	P	Supply voltage

(1) I-Input, O-Output, P-Power, G-Ground.

6.3 Marking Information

6.3.1 CJ74HC125

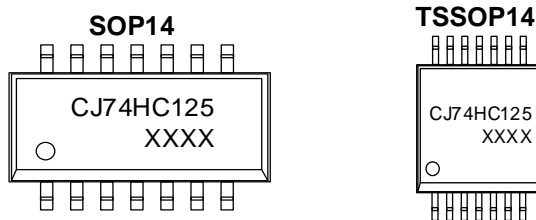

XXXX: Code, indicates weekly record information.

6.3.2 CJ74HCT125

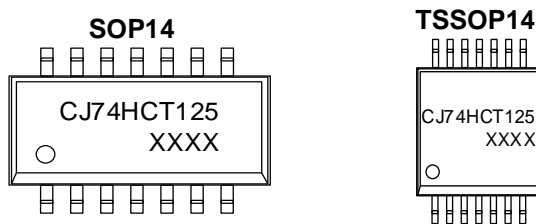

XXXX: Code, indicates weekly record information.

## 7 Specifications

### 7.1 Absolute Maximum Ratings

Voltages are referenced to GND(ground=0V), unless otherwise specified.

SYMBOL	PARAMETER	CONDITIONS		MIN.	MAX.	UNIT
V <sub>CC</sub>	Supply voltage	-		-0.5	+7	V
I <sub>IK</sub>	Input clamping current	V <sub>I</sub> < -0.5V or V <sub>I</sub> > V <sub>CC</sub> +0.5V		-	±20	mA
I <sub>OK</sub>	Output clamping current	V <sub>O</sub> < -0.5V or V <sub>O</sub> > V <sub>CC</sub> +0.5V		-	±20	mA
I <sub>O</sub>	Output current	-0.5V < V <sub>O</sub> < V <sub>CC</sub> +0.5V		-	±35	mA
I <sub>CC</sub>	Supply current	-		-	70	mA
I <sub>GND</sub>	Ground current	-		-70	-	mA
P <sub>tot</sub>	Total power dissipation	-		-	500	mW
T <sub>stg</sub>	Storage temperature	-		-65	+150	°C
T <sub>L</sub>	Soldering temperature	10s	SOP/TSSOP	-	260	°C

**Note:** Absolute maximum ratings indicate sustained limits beyond which damage to the device may occur. All voltage parameters are absolute voltages referenced to GND. The thermal resistance and power dissipation ratings are measured under board mounted and still air conditions.

### 7.2 Recommended Operating Conditions

SYMBOL	PARAMETER	CONDITIONS	MIN.	Typ.	MAX.	UNIT
<b>CJ74HC125</b>						
V <sub>CC</sub>	Supply voltage	-	2.0	5.0	6.0	V
V <sub>I</sub>	Input voltage	-	0	-	V <sub>CC</sub>	V
V <sub>O</sub>	Output voltage	-	0	-	V <sub>CC</sub>	V
Δt/ΔV	Input transition rise and fall rate	V <sub>CC</sub> =2.0V	-	-	625	ns/V
		V <sub>CC</sub> =4.5V	-	1.67	139	ns/V
		V <sub>CC</sub> =6.0V	-	-	83	ns/V
T <sub>amb</sub>	Ambient temperature	-	-40	-	+125	°C
<b>CJ74HCT125</b>						
V <sub>CC</sub>	Supply voltage	-	4.5	5.0	5.5	V
V <sub>I</sub>	Input voltage	-	0	-	V <sub>CC</sub>	V
V <sub>O</sub>	Output voltage	-	0	-	V <sub>CC</sub>	V
Δt/ΔV	Input transition rise and fall rate	V <sub>CC</sub> =4.5V	-	1.67	139	ns/V
T <sub>amb</sub>	Ambient temperature	-	-40	-	+125	°C

### 7.3 ESD Ratings

SYMBOL	ESD RATINGS		VALUE	UNIT
V <sub>ESD-HBM</sub>	Electrostatic discharge	Human body model (HBM) <sup>(1)</sup>	±2000	V

(1) JEDEC document JEP155 states that 500-V H1BM allows safe manufacturing with a standard ESD control process.

**7.4 Electrical Characteristics**
**7.4.1 DC Characteristics 1**
 $T_{amb}=25^{\circ}\text{C}$ , voltages are referenced to GND (ground=0V), unless otherwise specified.

SYMBOL	PARAMETER	CONDITIONS	MIN.	TYP.	MAX.	UNIT	
<b>CJ74HC125</b>							
$V_{IH}$	HIGH-level input voltage	$V_{CC}=2.0\text{V}$	1.5	-	-	V	
		$V_{CC}=4.5\text{V}$	3.15	-	-	V	
		$V_{CC}=6.0\text{V}$	4.2	-	-	V	
$V_{IL}$	LOW-level input voltage	$V_{CC}=2.0\text{V}$	-	-	0.5	V	
		$V_{CC}=4.5\text{V}$	-	-	1.35	V	
		$V_{CC}=6.0\text{V}$	-	-	1.8	V	
$V_{OH}$	HIGH-level output voltage	$V_I=V_{IH}$ or $V_{IL}$	$I_O=-20\mu\text{A}; V_{CC}=2.0\text{V}$	1.9	2.0	-	V
			$I_O=-20\mu\text{A}; V_{CC}=4.5\text{V}$	4.4	4.5	-	V
			$I_O=-20\mu\text{A}; V_{CC}=6.0\text{V}$	5.9	6.0	-	V
			$I_O=-6.0\text{mA}; V_{CC}=4.5\text{V}$	3.98	4.32	-	V
			$I_O=-7.8\text{mA}; V_{CC}=6.0\text{V}$	5.48	5.81	-	V
$V_{OL}$	LOW-level output voltage	$V_I=V_{IH}$ or $V_{IL}$	$I_O=20\mu\text{A}; V_{CC}=2.0\text{V}$	-	0	0.1	V
			$I_O=20\mu\text{A}; V_{CC}=4.5\text{V}$	-	0	0.1	V
			$I_O=20\mu\text{A}; V_{CC}=6.0\text{V}$	-	0	0.1	V
			$I_O=6.0\text{mA}; V_{CC}=4.5\text{V}$	-	0.15	0.26	V
			$I_O=7.8\text{mA}; V_{CC}=6.0\text{V}$	-	0.16	0.26	V
$I_I$	Input leakage current	$V_I=V_{CC}$ or GND; $V_{CC}=6.0\text{V}$	-	-	$\pm 1.0$	$\mu\text{A}$	
$I_{OZ}$	OFF-state output current	$V_I=V_{IH}$ or $V_{IL}; V_O=V_{CC}$ or GND; $V_{CC}=6.0\text{V}$	-	-	$\pm 1.0$	$\mu\text{A}$	
$I_{CC}$	Supply current	$V_I=V_{CC}$ or GND; $I_O=0\text{A}; V_{CC}=6.0\text{V}$	-	-	8.0	$\mu\text{A}$	
$C_I$	Input capacitance	-	-	3.5	-	pF	
<b>CJ74HCT125</b>							
$V_{IH}$	HIGH-level input voltage	$V_{CC}=4.5\text{V}$ to $5.5\text{V}$	2.0	-	-	V	
$V_{IL}$	LOW-level input voltage	$V_{CC}=4.5\text{V}$ to $5.5\text{V}$	-	-	0.8	V	
$V_{OH}$	HIGH-level output voltage	$V_I=V_{IH}$ or $V_{IL};$	$I_O=-20\mu\text{A}; V_{CC}=4.5\text{V}$	4.4	4.5	-	V
			$I_O=-6.0\text{mA}; V_{CC}=4.5\text{V}$	3.98	4.32	-	V
$V_{OL}$	LOW-level output voltage	$V_I=V_{IH}$ or $V_{IL};$	$I_O=20\mu\text{A}; V_{CC}=4.5\text{V}$	-	0	0.1	V
			$I_O=6.0\text{mA}; V_{CC}=4.5\text{V}$	-	0.16	0.26	V
$I_I$	Input leakage current	$V_I=V_{CC}$ or GND; $V_{CC}=5.5\text{V}$	-	-	$\pm 1$	$\mu\text{A}$	
$I_{OZ}$	OFF-state output current	$V_I=V_{IH}$ or $V_{IL}; V_O=V_{CC}$ or GND; $V_{CC}=5.5\text{V}$	-	-	$\pm 1$	$\mu\text{A}$	
$I_{CC}$	Supply current	$V_I=V_{CC}$ or GND; $I_O=0\text{A}; V_{CC}=5.5\text{V}$	-	-	8.0	$\mu\text{A}$	
$\Delta I_{CC}$	Additional supply current	Per input pin; $V_I=V_{CC}-2.1\text{V}; I_O=0\text{A};$ Other inputs at $V_{CC}$ or GND; $V_{CC}=4.5\text{V}$ to $5.5\text{V}$	-	-	360	$\mu\text{A}$	
$C_I$	Input capacitance	-	-	3.5	-	pF	

**7.4.2 DC Characteristics 2**
 $T_{amb} = -40^{\circ}\text{C}$  to  $+85^{\circ}\text{C}$ , voltages are referenced to GND (ground=0V), unless otherwise specified.

SYMBOL	PARAMETER	CONDITIONS	MIN.	TYP.	MAX.	UNIT	
<b>CJ74HC125</b>							
$V_{IH}$	HIGH-level input voltage	$V_{CC}=2.0\text{V}$	1.5	-	-	V	
		$V_{CC}=4.5\text{V}$	3.15	-	-	V	
		$V_{CC}=6.0\text{V}$	4.2	-	-	V	
$V_{IL}$	LOW-level input voltage	$V_{CC}=2.0\text{V}$	-	-	0.5	V	
		$V_{CC}=4.5\text{V}$	-	-	1.35	V	
		$V_{CC}=6.0\text{V}$	-	-	1.8	V	
$V_{OH}$	HIGH-level output voltage	$V_I = V_{IH}$ or $V_{IL}$	$I_O = -20\mu\text{A}; V_{CC} = 2.0\text{V}$	1.9	-	-	V
			$I_O = -20\mu\text{A}; V_{CC} = 4.5\text{V}$	4.4	-	-	V
			$I_O = -20\mu\text{A}; V_{CC} = 6.0\text{V}$	5.9	-	-	V
			$I_O = -6.0\text{mA}; V_{CC} = 4.5\text{V}$	3.84	-	-	V
			$I_O = -7.8\text{mA}; V_{CC} = 6.0\text{V}$	5.34	-	-	V
$V_{OL}$	LOW-level output voltage	$V_I = V_{IH}$ or $V_{IL}$	$I_O = 20\mu\text{A}; V_{CC} = 2.0\text{V}$	-	-	0.1	V
			$I_O = 20\mu\text{A}; V_{CC} = 4.5\text{V}$	-	-	0.1	V
			$I_O = 20\mu\text{A}; V_{CC} = 6.0\text{V}$	-	-	0.1	V
			$I_O = 6.0\text{mA}; V_{CC} = 4.5\text{V}$	-	-	0.33	V
			$I_O = 7.8\text{mA}; V_{CC} = 6.0\text{V}$	-	-	0.33	V
$I_I$	Input leakage current	$V_I = V_{CC}$ or GND; $V_{CC} = 6.0\text{V}$	-	-	$\pm 1$	$\mu\text{A}$	
$I_{OZ}$	OFF-state output current	$V_I = V_{IH}$ or $V_{IL}; V_O = V_{CC}$ or GND; $V_{CC} = 6.0\text{V}$	-	-	$\pm 5$	$\mu\text{A}$	
$I_{CC}$	Supply current	$V_I = V_{CC}$ or GND; $I_O = 0\text{A}; V_{CC} = 6.0\text{V}$	-	-	80	$\mu\text{A}$	
<b>CJ74HCT125</b>							
$V_{IH}$	HIGH-level input voltage	$V_{CC} = 4.5\text{V}$ to $5.5\text{V}$	2.0	-	-	V	
$V_{IL}$	LOW-level input voltage	$V_{CC} = 4.5\text{V}$ to $5.5\text{V}$	-	-	0.8	V	
$V_{OH}$	HIGH-level output voltage	$V_I = V_{IH}$ or $V_{IL}$	$I_O = -20\mu\text{A}; V_{CC} = 4.5\text{V}$	4.4	-	-	V
			$I_O = -6.0\text{mA}; V_{CC} = 4.5\text{V}$	3.84	-	-	V
$V_{OL}$	LOW-level output voltage	$V_I = V_{IH}$ or $V_{IL}$	$I_O = 20\mu\text{A}; V_{CC} = 4.5\text{V}$	-	-	0.1	V
			$I_O = 6.0\text{mA}; V_{CC} = 4.5\text{V}$	-	-	0.33	V
$I_I$	Input leakage current	$V_I = V_{CC}$ or GND; $V_{CC} = 5.5\text{V}$	-	-	$\pm 1$	$\mu\text{A}$	
$I_{OZ}$	OFF-state output current	$V_I = V_{IH}$ or $V_{IL}; V_O = V_{CC}$ or GND; $V_{CC} = 5.5\text{V}$	-	-	$\pm 5$	$\mu\text{A}$	
$I_{CC}$	Supply current	$V_I = V_{CC}$ or GND; $I_O = 0\text{A}; V_{CC} = 5.5\text{V}$	-	-	80	$\mu\text{A}$	
$\Delta I_{CC}$	Additional supply current	Per input pin; $V_I = V_{CC} - 2.1\text{V};$ $I_O = 0\text{A};$ Other inputs at $V_{CC}$ or GND; $V_{CC} = 4.5\text{V}$ to $5.5\text{V}$	-	-	450	$\mu\text{A}$	

**7.4.3 DC Characteristics 3**
 $T_{amb} = -40^{\circ}\text{C}$  to  $+125^{\circ}\text{C}$ , voltages are referenced to GND (ground=0V), unless otherwise specified.

SYMBOL	PARAMETER	CONDITIONS	MIN.	TYP.	MAX.	UNIT	
<b>CJ74HC125</b>							
$V_{IH}$	HIGH-level input voltage	$V_{CC}=2.0\text{V}$	1.5	-	-	V	
		$V_{CC}=4.5\text{V}$	3.15	-	-	V	
		$V_{CC}=6.0\text{V}$	4.2	-	-	V	
$V_{IL}$	LOW-level input voltage	$V_{CC}=2.0\text{V}$	-	-	0.5	V	
		$V_{CC}=4.5\text{V}$	-	-	1.35	V	
		$V_{CC}=6.0\text{V}$	-	-	1.8	V	
$V_{OH}$	HIGH-level output voltage	$V_I = V_{IH}$ or $V_{IL}$	$I_O = -20\mu\text{A}; V_{CC} = 2.0\text{V}$	1.9	-	-	V
			$I_O = -20\mu\text{A}; V_{CC} = 4.5\text{V}$	4.4	-	-	V
			$I_O = -20\mu\text{A}; V_{CC} = 6.0\text{V}$	5.9	-	-	V
			$I_O = -6.0\text{mA}; V_{CC} = 4.5\text{V}$	3.7	-	-	V
			$I_O = -7.8\text{mA}; V_{CC} = 6.0\text{V}$	5.2	-	-	V
$V_{OL}$	LOW-level output voltage	$V_I = V_{IH}$ or $V_{IL}$	$I_O = 20\mu\text{A}; V_{CC} = 2.0\text{V}$	-	-	0.1	V
			$I_O = 20\mu\text{A}; V_{CC} = 4.5\text{V}$	-	-	0.1	V
			$I_O = 20\mu\text{A}; V_{CC} = 6.0\text{V}$	-	-	0.1	V
			$I_O = 6.0\text{mA}; V_{CC} = 4.5\text{V}$	-	-	0.4	V
			$I_O = 7.8\text{mA}; V_{CC} = 6.0\text{V}$	-	-	0.4	V
$I_i$	Input leakage current	$V_I = V_{CC}$ or GND; $V_{CC} = 6.0\text{V}$	-	-	$\pm 1$	$\mu\text{A}$	
$I_{OZ}$	OFF-state output current	$V_I = V_{IH}$ or $V_{IL}; V_O = V_{CC}$ or GND; $V_{CC} = 6.0\text{V}$	-	-	$\pm 10$	$\mu\text{A}$	
$I_{CC}$	Supply current	$V_I = V_{CC}$ or GND; $I_O = 0\text{A}; V_{CC} = 6.0\text{V}$	-	-	160	$\mu\text{A}$	
<b>CJ74HCT125</b>							
$V_{IH}$	HIGH-level input voltage	$V_{CC} = 4.5\text{V}$ to $5.5\text{V}$	2.0	-	-	V	
$V_{IL}$	LOW-level input voltage	$V_{CC} = 4.5\text{V}$ to $5.5\text{V}$	-	-	0.8	V	
$V_{OH}$	HIGH-level output voltage	$V_I = V_{IH}$ or $V_{IL};$	$I_O = -20\mu\text{A}; V_{CC} = 4.5\text{V}$	4.4	-	-	V
			$I_O = -6.0\text{mA}; V_{CC} = 4.5\text{V}$	3.7	-	-	V
$V_{OL}$	LOW-level output voltage	$V_I = V_{IH}$ or $V_{IL};$	$I_O = 20\mu\text{A}; V_{CC} = 4.5\text{V}$	-	-	0.1	V
			$I_O = 6.0\text{mA}; V_{CC} = 4.5\text{V}$	-	-	0.4	V
$I_i$	Input leakage current	$V_I = V_{CC}$ or GND; $V_{CC} = 5.5\text{V}$	-	-	$\pm 1$	$\mu\text{A}$	
$I_{OZ}$	OFF-state output current	$V_I = V_{IH}$ or $V_{IL}; V_O = V_{CC}$ or GND; $V_{CC} = 5.5\text{V}$	-	-	$\pm 10$	$\mu\text{A}$	
$I_{CC}$	Supply current	$V_I = V_{CC}$ or GND; $I_O = 0\text{A}; V_{CC} = 5.5\text{V}$	-	-	160	$\mu\text{A}$	
$\Delta I_{CC}$	Additional supply current	Per input pin; $V_I = V_{CC} - 2.1\text{V};$ $I_O = 0\text{A};$ Other inputs at $V_{CC}$ or GND; $V_{CC} = 4.5\text{V}$ to $5.5\text{V}$	-	-	490	$\mu\text{A}$	

**7.4.4 AC Characteristics 1**

 T<sub>amb</sub>=25°C, voltages are referenced to GND (ground=0V), unless otherwise specified.

SYMBOL	PARAMETER	CONDITIONS	MIN.	TYP.	MAX.	UNIT	
<b>CJ74HC125</b>							
t <sub>pd</sub>	nA to nY propagation delay	See Figure 8-5 <sup>(1)</sup>	V <sub>CC</sub> =2.0V	-	30	100	ns
			V <sub>CC</sub> =4.5V	-	11	20	ns
			V <sub>CC</sub> =5.0V; C <sub>L</sub> =15pF	-	9	-	ns
			V <sub>CC</sub> =6.0V	-	9	17	ns
t <sub>en</sub>	nOE to nY enable time	See Figure 8-6 <sup>(2)</sup>	V <sub>CC</sub> =2.0V	-	41	125	ns
			V <sub>CC</sub> =4.5V	-	15	25	ns
			V <sub>CC</sub> =6.0V	-	12	21	ns
t <sub>dis</sub>	nOE to nY disable time	See Figure 8-6 <sup>(3)</sup>	V <sub>CC</sub> =2.0V	-	41	125	ns
			V <sub>CC</sub> =4.5V	-	15	25	ns
			V <sub>CC</sub> =6.0V	-	12	21	ns
t <sub>t</sub>	Transition time	See Figure 8-5 <sup>(4)</sup>	V <sub>CC</sub> =2.0V	-	14	60	ns
			V <sub>CC</sub> =4.5V	-	5	12	ns
			V <sub>CC</sub> =6.0V	-	4	10	ns
C <sub>PD</sub>	Power dissipation capacitance	C <sub>L</sub> =50pF; f=1MHz; V <sub>I</sub> =GND to V <sub>CC</sub> <sup>(5)</sup>	-	22	-	pF	
<b>CJ74HCT125</b>							
t <sub>pd</sub>	nA to nY propagation delay	See Figure 8-5 <sup>(1)</sup>	V <sub>CC</sub> =4.5V	-	15	25	ns
			V <sub>CC</sub> =5.0V; C <sub>L</sub> =15pF	-	12	-	ns
t <sub>en</sub>	nOE to nY enable time	See Figure 8-6 <sup>(2)</sup>	V <sub>CC</sub> =4.5V	-	15	28	ns
t <sub>dis</sub>	nOE to nY disable time	See Figure 8-6 <sup>(3)</sup>	V <sub>CC</sub> =4.5V	-	15	25	ns
t <sub>t</sub>	Transition time	See Figure 8-5 <sup>(4)</sup>	V <sub>CC</sub> =4.5V	-	5	12	ns
C <sub>PD</sub>	Power dissipation capacitance	C <sub>L</sub> =50pF; f=1MHz; V <sub>I</sub> =GND to V <sub>CC</sub> -1.5V <sup>(5)</sup>	-	24	-	pF	

 (1) t<sub>pd</sub> is the same as t<sub>PLH</sub> and t<sub>PHL</sub>.

 (2) t<sub>en</sub> is the same as t<sub>PZL</sub> and t<sub>PZH</sub>.

 (3) t<sub>dis</sub> is the same as t<sub>PLZ</sub> and t<sub>PHZ</sub>.

 (4) t<sub>t</sub> is the same as t<sub>THL</sub> and t<sub>TLH</sub>.

 (5) C<sub>PD</sub> is used to determine the dynamic power dissipation (P<sub>D</sub> in uW).

$$P_D = (C_{PD} \times V_{CC}^2 \times f_i \times N) + \sum (C_L \times V_{CC}^2 \times f_o)$$
 where:

 f<sub>i</sub>=input frequency in MHz;

 f<sub>o</sub>=output frequency in MHz;

 C<sub>L</sub>=output load capacitance in pF;

 V<sub>CC</sub>=supply voltage in V;

N=number of inputs switching;

 $\sum (C_L \times V_{CC}^2 \times f_o)$ =sum of outputs.

**7.4.5 AC Characteristics 2**
 $T_{amb} = -40^{\circ}\text{C}$  to  $+85^{\circ}\text{C}$ , voltages are referenced to GND (ground=0V), unless otherwise specified.

SYMBOL	PARAMETER	CONDITIONS	MIN.	TYP.	MAX.	UNIT	
<b>CJ74HC125</b>							
$t_{pd}$	nA to nY propagation delay	See Figure 8-5 <sup>(1)</sup>	$V_{CC}=2.0\text{V}$	-	-	125	ns
			$V_{CC}=4.5\text{V}$	-	-	25	ns
			$V_{CC}=6.0\text{V}$	-	-	21	ns
$t_{en}$	$\overline{\text{nOE}}$ to nY enable time	See Figure 8-6 <sup>(2)</sup>	$V_{CC}=2.0\text{V}$	-	-	155	ns
			$V_{CC}=4.5\text{V}$	-	-	31	ns
			$V_{CC}=6.0\text{V}$	-	-	26	ns
$t_{dis}$	$\overline{\text{nOE}}$ to nY disable time	See Figure 8-6 <sup>(3)</sup>	$V_{CC}=2.0\text{V}$	-	-	155	ns
			$V_{CC}=4.5\text{V}$	-	-	31	ns
			$V_{CC}=6.0\text{V}$	-	-	26	ns
$t_t$	Transition time	See Figure 8-5 <sup>(4)</sup>	$V_{CC}=2.0\text{V}$	-	-	75	ns
			$V_{CC}=4.5\text{V}$	-	-	15	ns
			$V_{CC}=6.0\text{V}$	-	-	13	ns
<b>CJ74HCT125</b>							
$t_{pd}$	nA to nY propagation delay	See Figure 8-5 <sup>(1)</sup>	$V_{CC}=4.5\text{V}$	-	-	31	ns
$t_{en}$	$\overline{\text{nOE}}$ to nY enable time	See Figure 8-6 <sup>(2)</sup>	$V_{CC}=4.5\text{V}$	-	-	35	ns
$t_{dis}$	$\overline{\text{nOE}}$ to nY disable time	See Figure 8-6 <sup>(3)</sup>	$V_{CC}=4.5\text{V}$	-	-	31	ns
$t_t$	Transition time	See Figure 8-5 <sup>(4)</sup>	$V_{CC}=4.5\text{V}$	-	-	15	ns

(1)  $t_{pd}$  is the same as  $t_{PLH}$  and  $t_{PHL}$ .

(2)  $t_{en}$  is the same as  $t_{PZL}$  and  $t_{PZH}$ .

(3)  $t_{dis}$  is the same as  $t_{PLZ}$  and  $t_{PHZ}$ .

(4)  $t_t$  is the same as  $t_{THL}$  and  $t_{TLH}$ .

**7.4.6 AC Characteristics 3**
 $T_{amb} = -40^{\circ}\text{C}$  to  $+125^{\circ}\text{C}$ , voltages are referenced to GND (ground=0V), unless otherwise specified.

SYMBOL	PARAMETER	CONDITIONS	MIN.	TYP.	MAX.	UNIT	
<b>CJ74HC125</b>							
$t_{pd}$	nA to nY propagation delay	See Figure 8-5 <sup>(1)</sup>	$V_{CC}=2.0\text{V}$	-	-	150	ns
			$V_{CC}=4.5\text{V}$	-	-	30	ns
			$V_{CC}=6.0\text{V}$	-	-	26	ns
$t_{en}$	$\overline{\text{nOE}}$ to nY enable time	See Figure 8-6 <sup>(2)</sup>	$V_{CC}=2.0\text{V}$	-	-	190	ns
			$V_{CC}=4.5\text{V}$	-	-	38	ns
			$V_{CC}=6.0\text{V}$	-	-	32	ns
$t_{dis}$	$\overline{\text{nOE}}$ to nY disable time	See Figure 8-6 <sup>(3)</sup>	$V_{CC}=2.0\text{V}$	-	-	190	ns
			$V_{CC}=4.5\text{V}$	-	-	38	ns
			$V_{CC}=6.0\text{V}$	-	-	32	ns
$t_t$	Transition time	See Figure 8-5 <sup>(4)</sup>	$V_{CC}=2.0\text{V}$	-	-	90	ns
			$V_{CC}=4.5\text{V}$	-	-	18	ns
			$V_{CC}=6.0\text{V}$	-	-	15	ns
<b>CJ74HCT125</b>							
$t_{pd}$	nA to nY propagation delay	See Figure 8-5 <sup>(1)</sup>	$V_{CC}=4.5\text{V}$	-	-	38	ns
$t_{en}$	$\overline{\text{nOE}}$ to nY enable time	See Figure 8-6 <sup>(2)</sup>	$V_{CC}=4.5\text{V}$	-	-	42	ns
$t_{dis}$	$\overline{\text{nOE}}$ to nY disable time	See Figure 8-6 <sup>(3)</sup>	$V_{CC}=4.5\text{V}$	-	-	38	ns
$t_t$	Transition time	See Figure 8-5 <sup>(4)</sup>	$V_{CC}=4.5\text{V}$	-	-	18	ns

(1)  $t_{pd}$  is the same as  $t_{PLH}$  and  $t_{PHL}$ .

(2)  $t_{en}$  is the same as  $t_{PZL}$  and  $t_{PZH}$ .

(3)  $t_{dis}$  is the same as  $t_{PLZ}$  and  $t_{PHZ}$ .

(4)  $t_t$  is the same as  $t_{THL}$  and  $t_{TLH}$ .

## 8 Detailed Description

### 8.1 Overview

The CJ74HC/HCT125 is a quad buffer/line driver with 3-state outputs controlled by the output enable inputs (/nOE). A HIGH on /nOE causes the outputs to assume a high-impedance OFF-state. Inputs include clamp diodes. This enables the use of current limiting resistors to interface inputs to voltages in excess of V<sub>CC</sub>.

### 8.2 Functional Block Diagram

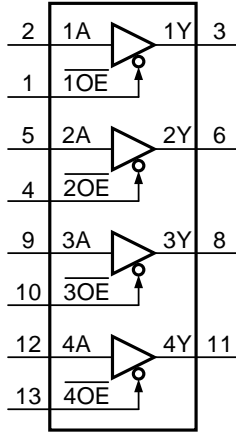

Figure 8-1 Logic symbol

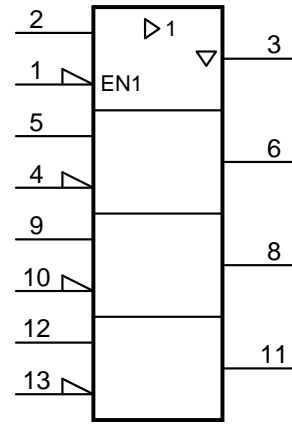

Figure 8-2 IEC logic symbol

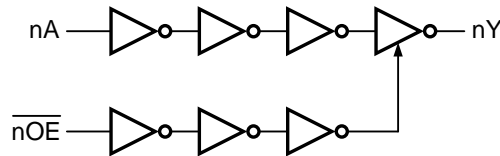

Figure 8-3 Logic diagram for one gate

### 8.3 Function Table<sup>(1)</sup>

CONTROL	INPUT	OUTPUT
$\overline{nOE}$	nA	nY
L	L	L
L	H	H
H	X	Z

(1) H=HIGH voltage level; L=LOW voltage level; X=don't care; Z=high-impedance OFF-state.

8.4 Testing Circuit

8.4.1 AC Testing Circuit

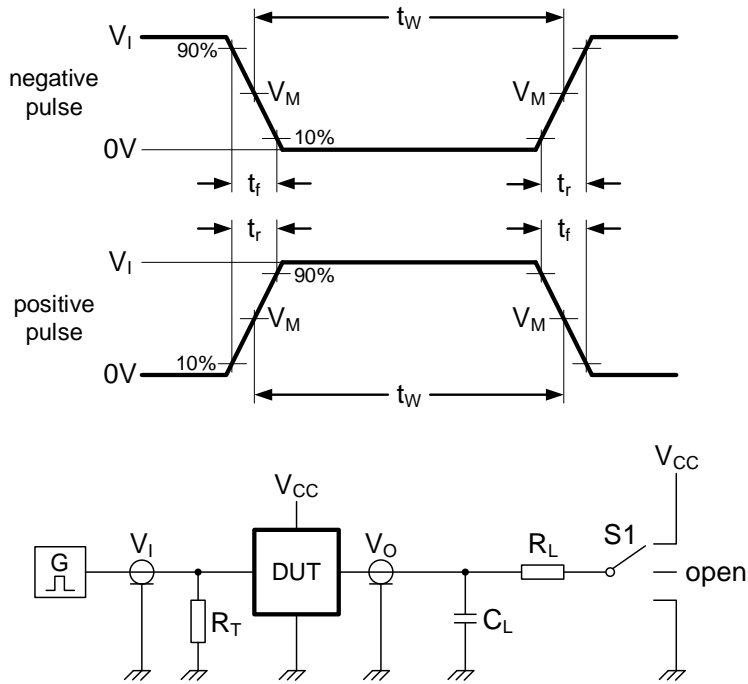

Figure 8-4 Test circuit for measuring switching times

Definitions for test circuit:

$C_L$ =Load capacitance including jig and probe capacitance.

$R_T$ =Termination resistance should be equal to the output impedance  $Z_o$  of the pulse generator.

$R_L$ =Load resistance.

S1=Test selection switch.

8.4.2 AC Testing Waveforms

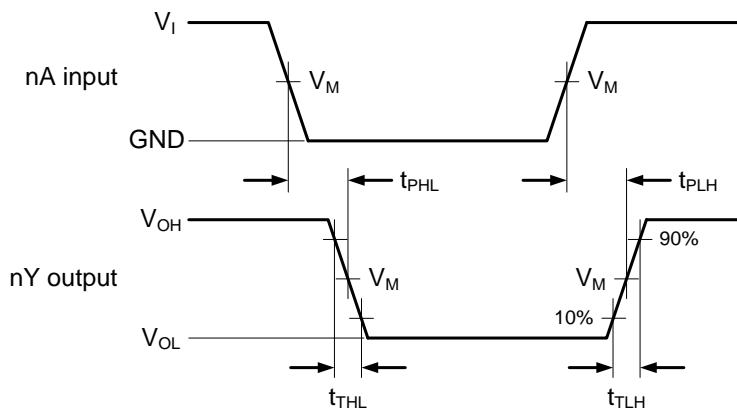

Figure 8-5 Propagation delay input (nA) to output (nY)

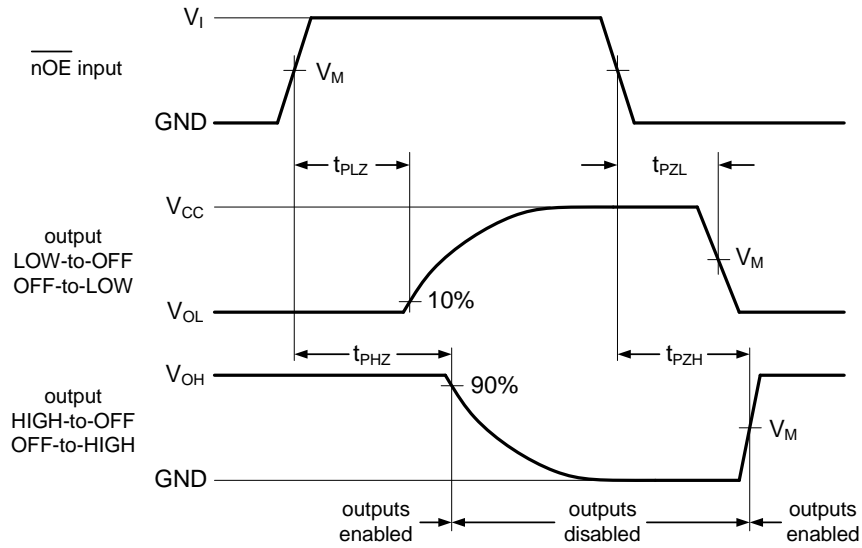

Figure 8-6 Enable and disable times

8.4.3 Measurement Points

TYPE	INPUT	OUTPUT
	$V_M$	$V_M$
CJ74HC125	$0.5 \times V_{CC}$	$0.5 \times V_{CC}$
CJ74HCT125	1.3V	1.3V

8.4.4 Test Data

TYPE	INPUT		LOAD		S1 POSITION		
	$V_I$	$t_r, t_f$	$C_L$	$R_L$	$t_{PHL}, t_{PLH}$	$t_{PZH}, t_{PHZ}$	$t_{PZL}, t_{PLZ}$
CJ74HC125	$V_{CC}$	6ns	15pF, 50pF	1k $\Omega$	Open	GND	$V_{CC}$
CJ74HCT125	3V	6ns	15pF, 50pF	1k $\Omega$	Open	GND	$V_{CC}$

9 Mechanical Information

9.1 SOP14 Mechanical Information

9.1.1 SOP14 Outline Dimensions

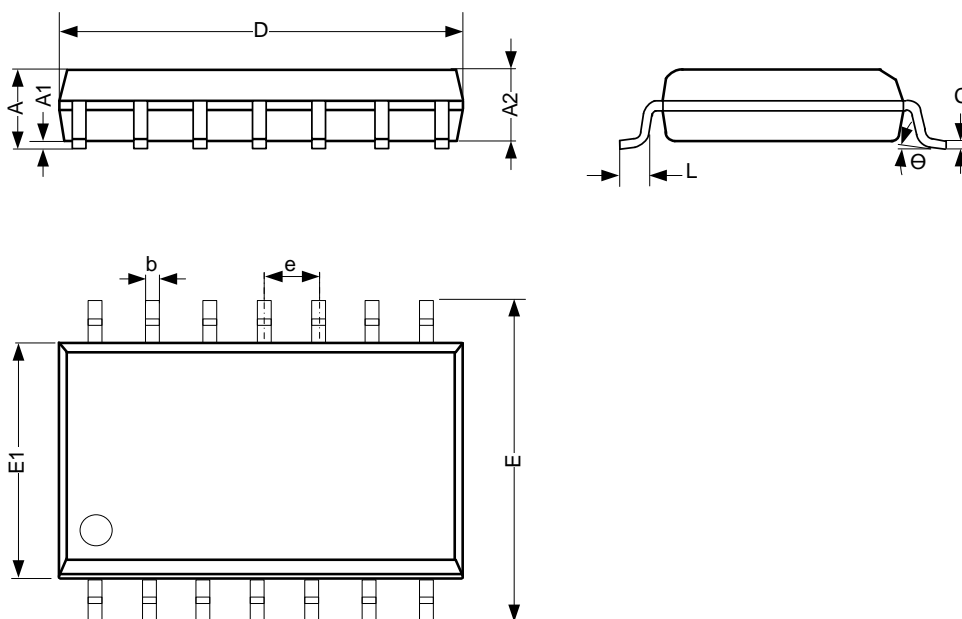

SYMBOL	Dimensions In Millimeters		
	Min.	Typ.	Max.
A	1.50	-	1.75
A1	0.05	-	0.25
A2	1.30	-	-
b	0.33	-	0.50
c	0.19	-	0.25
D	8.43	-	8.76
E	5.80	-	6.25
E1	3.75	-	4.00
e	1.27 BSC		
L	0.40	-	0.89
θ	0°	-	8°
Unit: mm			

9.2 TSSOP14 Mechanical Information

9.2.1 TSSOP14 Outline Dimensions

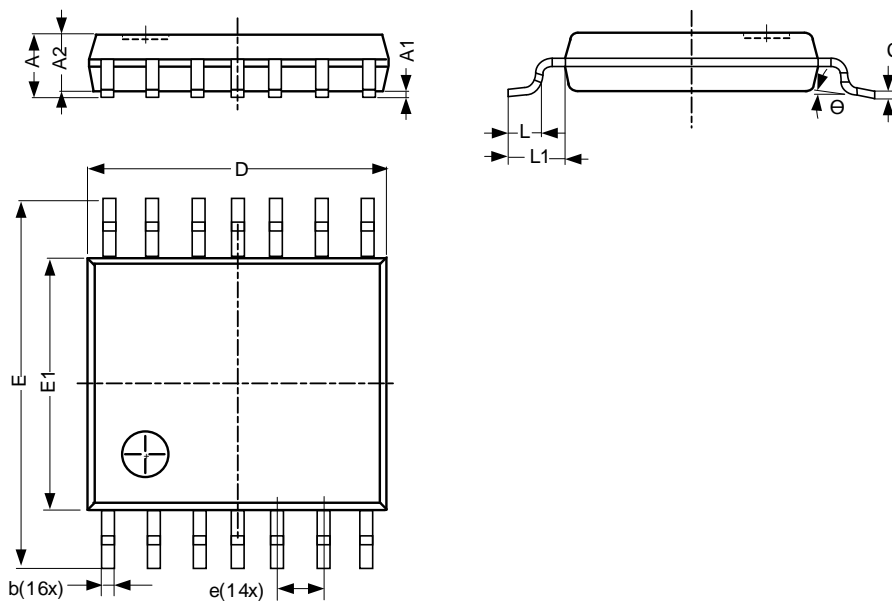

SYMBOL	Dimensions In Millimeters		
	Min.	Typ.	Max.
A	-	-	1.20
A1	0.05	-	0.15
A2	0.80	-	1.05
b	0.19	-	0.30
c	0.09	-	0.20
D	4.90	-	5.10
E	6.20	-	6.60
E1	4.30	-	4.50
e	0.65 BSC		
L	0.45	-	0.75
L1	-	1.00	-
θ	0°	-	8°
Unit: mm			

## 10 Notes and Revision History

### 10.1 Associated Product Family and Others

To view other products of the same type or IC products of other types, click the official website of JSCJ -- <https://www.jscj-elec.com> for more details.

### 10.2 Notes

#### Electrostatic Discharge Caution



This IC may be damaged by ESD. Relevant personnel shall comply with correct installation and use specifications to avoid ESD damage to the IC. If appropriate measures are not taken to prevent ESD damage, the hazards caused by ESD include but are not limited to degradation of integrated circuit performance or complete damage of integrated circuit. For some precision integrated circuits, a very small parameter change may cause the whole device to be inconsistent with its published specifications.

### 10.3 Revision History

November, 2025: rev - 1.1, Change marking information.

# DISCLAIMER

## IMPORTANT NOTICE, PLEASE READ CAREFULLY

The information in this data sheet is intended to describe the operation and characteristics of our products. JSCJ has the right to make any modification, enhancement, improvement, correction or other changes to any content in this data sheet, including but not limited to specification parameters, circuit design and application information, without prior notice.

Any person who purchases or uses JSCJ products for design shall: 1. Select products suitable for circuit application and design; 2. Design, verify and test the rationality of circuit design; 3. Procedures to ensure that the design complies with relevant laws and regulations and the requirements of such laws and regulations. JSCJ makes no warranty or representation as to the accuracy or completeness of the information contained in this data sheet and assumes no responsibility for the application or use of any of the products described in this data sheet.

Without the written consent of JSCJ, this product shall not be used in occasions requiring high quality or high reliability, including but not limited to the following occasions: medical equipment, military facilities and aerospace. JSCJ shall not be responsible for casualties or property losses caused by abnormal use or application of this product.

Official Website: [www.jscj-elec.com](http://www.jscj-elec.com)

Copyright © JIANGSU CHANGJING ELECTRONICS TECHNOLOGY CO., LTD