

Single 2-input NAND Gate

CJ74LVC1G00 **Logic**

1 Introduction

The CJ74LVC1G00 provides the single 2-input NAND function.

Input can be driven from either 3.3V or 5V devices. These features allow the use of these devices in a mixed 3.3V and 5V environment.

2 Available Packages

PART NUMBER	PACKAGE
CJ74LVC1G00	SOT-23-5L
	SOT-353
	DFN1x1-6L

Note: For all available packages, please refer to the part Orderable Information.

3 Features

- Wide supply voltage range from 1.65V to 5.5V
- $\pm 24\text{mA}$ output drive ($V_{CC}=3.0\text{V}$)
- CMOS low power consumption
- Input accepts voltages up to 5V
- Specified from -40°C to $+125^{\circ}\text{C}$

4 Applications

- AV Receiver
- Audio Dock: Portable
- Blu-ray Player and Home Theater
- Embedded PC
- MP3 Player/Recorder (Portable Audio)
- Personal Digital Assistant (PDA)
- Power: Telecom/Server AC/DC Supply: Single Controller: Analog and Digital
- Solid State Drive (SSD): Client and Enterprise
- TV: LCD/Digital and High-Definition (HDTV)
- Tablet: Enterprise
- Video Analytics: Server
- Wireless Headset, Keyboard, and Mouse



Simplified diagram

5 Orderable Information

DEVICE	PACKAGE	OP TEMP	ECO PLAN	MSL	PACKING OPTION	SORT
CJ74LVC1G00M5N	SOT-23-5L	-40~125°C	RoHS & Green	Level 3 168HR	Tape and Reel 3000 Units / Reel	Active
CJ74LVC1G00R5N	SOT-353	-40~125°C	RoHS & Green	Level 3 168HR	Tape and Reel 3000 Units / Reel	Active
CJ74LVC1G00DKN	DFN1x1-6L	-40~125°C	RoHS & Green	Level 3 168HR	Tape and Reel 5000 Units / Reel	Active

Note:

ECO PLAN: For the RoHS and Green certification standards of this product, please refer to the official report provided by JSCJ.

MSL: Moisture Sensitivity Level. Determined according to JEDEC industry standard classification.

SORT: Specifically defined as follows:

Active: Recommended for new products;

Customized: Products manufactured to meet the specific needs of customers;

Preview: The device has been released and has not been fully mass produced. The sample may or may not be available;

NoRD: It is not recommended to use the device for new design. The device is only produced for the needs of existing customers;

Obsolete: The device has been discontinued.

6 Pin Configuration and Marking Information

6.1 Pin Configuration

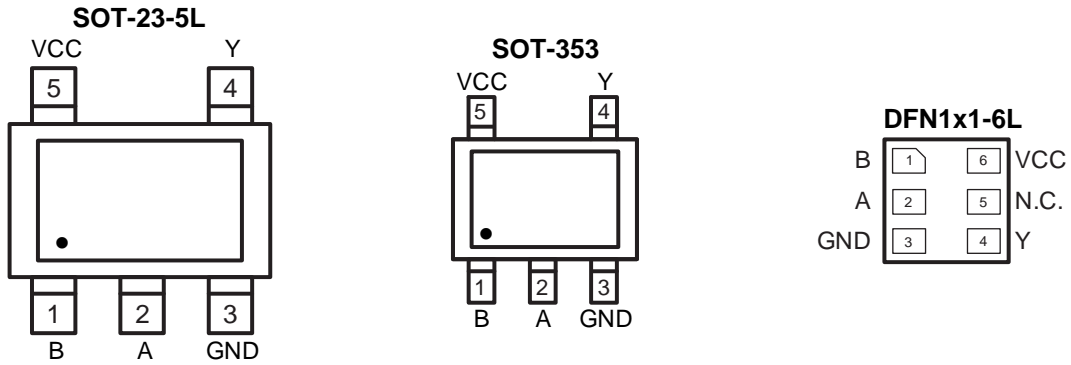

Figure 6-1 Pin configuration

6.2 Pin Function

PIN		NAME	I/O ⁽¹⁾	DESCRIPTION
No.				
SOT-23-5L/SOT-353	DFN1x1-6L			
1	1	B	I	Data input
2	2	A	I	Data input
3	3	GND	G	Ground (0V)
4	4	Y	O	Data output
-	5	N.C.	-	Not connected
5	6	VCC	P	Supply voltage

(1) I-Input, O-Output, P-Power, G-Ground

6.3 Marking Information

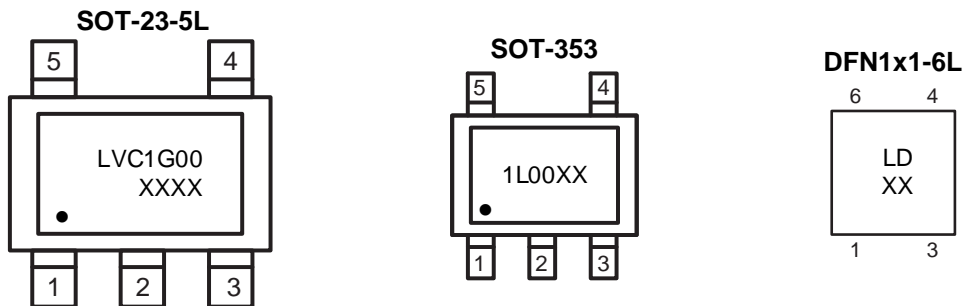

XXXX or XX: Code, indicates weekly record information.

7 Specifications

7.1 Absolute Maximum Ratings

Voltages are referenced to GND (ground=0V), unless otherwise specified.

SYMBOL	PARAMETER	CONDITIONS	MIN.	MAX.	UNIT
V _{CC}	Supply voltage	-	-0.5	+6.5	V
I _{IK}	Input clamping current	V _I < 0V	-50	-	mA
V _I	Input voltage	-	-0.5	+6.5	V
I _{OK}	Output clamping current	V _O > V _{CC} or V _O < 0V	-	±50	mA
V _O	Output voltage	Active mode	-0.5	V _{CC} +0.5	V
		Power-down mode	-0.5	+6.5	V
I _O	Output current	V _O =0V to V _{CC}	-	±50	mA
I _{CC}	Supply current	-	-	100	mA
I _{GND}	Ground current	-	-100	-	mA
T _{stg}	Storage temperature	-	-65	+150	°C
P _{tot}	Total power dissipation	-	-	250	mW
T _L	Soldering temperature	10s	-	260	°C

Note: Absolute maximum ratings indicate sustained limits beyond which damage to the device may occur. All voltage parameters are absolute voltages referenced to GND. The thermal resistance and power dissipation ratings are measured under board mounted and still air conditions.

7.2 Recommended Operating Conditions

SYMBOL	PARAMETER	CONDITIONS	MIN.	TYP.	MAX.	UNIT
V _{CC}	Supply voltage	-	1.65	-	5.5	V
V _I	Input voltage	-	0	-	5.5	V
V _O	Output voltage	Active mode	0	-	V _{CC}	V
		Power-down mode; V _{CC} =0V	0	-	5.5	V
T _{amb}	Ambient temperature	-	-40	-	+125	°C

7.3 ESD Ratings

SYMBOL	ESD RATINGS		VALUE	UNIT
V _{ESD-HBM}	Electrostatic discharge	Human body model (HBM) ⁽¹⁾	±2000	V

(1) JEDEC document JEP155 states that 500-V HBM allows safe manufacturing with a standard ESD control process.

7.4 Electrical Characteristics
7.4.1 DC Characteristics 1
 $T_{amb} = -40^{\circ}\text{C}$ to $+85^{\circ}\text{C}$, voltages are referenced to GND (ground=0V), unless otherwise specified.

SYMBOL	PARAMETER	CONDITIONS	MIN.	TYP.	MAX.	UNIT	
V_{IH}	HIGH-level input voltage	$V_{CC}=1.65\text{V}$ to 1.95V	$0.65 \times V_{CC}$	-	-	V	
		$V_{CC}=2.3\text{V}$ to 2.7V	1.7	-	-	V	
		$V_{CC}=2.7\text{V}$ to 3.6V	2.0	-	-	V	
		$V_{CC}=4.5\text{V}$ to 5.5V	$0.7 \times V_{CC}$	-	-	V	
V_{IL}	LOW-level input voltage	$V_{CC}=1.65\text{V}$ to 1.95V	-	-	$0.35 \times V_{CC}$	V	
		$V_{CC}=2.3\text{V}$ to 2.7V	-	-	0.7	V	
		$V_{CC}=2.7\text{V}$ to 3.6V	-	-	0.8	V	
		$V_{CC}=4.5\text{V}$ to 5.5V	-	-	$0.3 \times V_{CC}$	V	
V_{OH}	HIGH-level output voltage	$V_I = V_{IH}$ or V_{IL}	$I_o = -100\mu\text{A}$; $V_{CC}=1.65\text{V}$ to 5.5V	$V_{CC} - 0.1$	-	-	V
			$I_o = -4\text{mA}$; $V_{CC}=1.65\text{V}$	1.2	-	-	V
			$I_o = -8\text{mA}$; $V_{CC}=2.3\text{V}$	1.9	-	-	V
			$I_o = -12\text{mA}$; $V_{CC}=2.7\text{V}$	2.2	-	-	V
			$I_o = -24\text{mA}$; $V_{CC}=3.0\text{V}$	2.3	-	-	V
			$I_o = -32\text{mA}$; $V_{CC}=4.5\text{V}$	3.8	-	-	V
V_{OL}	LOW-level output voltage	$V_I = V_{IH}$ or V_{IL}	$I_o = 100\mu\text{A}$; $V_{CC}=1.65\text{V}$ to 5.5V	-	-	0.1	V
			$I_o = 4\text{mA}$; $V_{CC}=1.65\text{V}$	-	-	0.45	V
			$I_o = 8\text{mA}$; $V_{CC}=2.3\text{V}$	-	-	0.3	V
			$I_o = 12\text{mA}$; $V_{CC}=2.7\text{V}$	-	-	0.4	V
			$I_o = 24\text{mA}$; $V_{CC}=3.0\text{V}$	-	-	0.55	V
			$I_o = 32\text{mA}$; $V_{CC}=4.5\text{V}$	-	-	0.55	V
I_i	Input leakage current	$V_I = 5.5\text{V}$ or GND; $V_{CC} = 0\text{V}$ to 5.5V	-	-	± 1	μA	
I_{OFF}	Power-off leakage current	V_I or $V_O = 5.5\text{V}$; $V_{CC} = 0\text{V}$	-	-	± 2	μA	
I_{CC}	Supply current	$V_I = 5.5\text{V}$ or GND; $I_o = 0\text{A}$; $V_{CC} = 1.65\text{V}$ to 5.5V	-	-	4	μA	
ΔI_{CC}	Additional supply current	Per pin; $V_I = V_{CC} - 0.6\text{V}$; $I_o = 0\text{A}$; $V_{CC} = 2.3\text{V}$ to 5.5V	-	-	500	μA	
C_i	Input capacitance	$V_{CC} = 3.3\text{V}$; $V_I = \text{GND}$ to V_{CC}	-	5	-	pF	

(1) All typical values are measured at $V_{CC} = 3.3\text{V}$ and $T_{amb} = 25^{\circ}\text{C}$.

7.4.2 DC Characteristics 2

 T_{amb}=-40°C to +125°C, voltages are referenced to GND (ground=0V), unless otherwise specified.

SYMBOL	PARAMETER	CONDITIONS	MIN.	TYP.	MAX.	UNIT	
V _{IH}	HIGH-level input voltage	V _{CC} =1.65V to 1.95V	0.65xV _{CC}	-	-	V	
		V _{CC} =2.3V to 2.7V	1.7	-	-	V	
		V _{CC} =2.7V to 3.6V	2.0	-	-	V	
		V _{CC} =4.5V to 5.5V	0.7xV _{CC}	-	-	V	
V _{IL}	LOW-level input voltage	V _{CC} =1.65V to 1.95V	-	-	0.35xV _{CC}	V	
		V _{CC} =2.3V to 2.7V	-	-	0.7	V	
		V _{CC} =2.7V to 3.6V	-	-	0.8	V	
		V _{CC} =4.5V to 5.5V	-	-	0.3xV _{CC}	V	
V _{OH}	HIGH-level output voltage	V _I = V _{IH} or V _{IL}	I _O =-100uA; V _{CC} =1.65V to 5.5V	V _{CC} - 0.1	-	-	V
			I _O =-4mA; V _{CC} =1.65V	0.95	-	-	V
			I _O =-8mA; V _{CC} =2.3V	1.7	-	-	V
			I _O =-12mA; V _{CC} =2.7V	1.9	-	-	V
			I _O =-24mA; V _{CC} =3.0V	2.0	-	-	V
			I _O =-32mA; V _{CC} =4.5V	3.4	-	-	V
V _{OL}	LOW-level output voltage	V _I = V _{IH} or V _{IL}	I _O =100uA; V _{CC} =1.65V to 5.5V	-	-	0.1	V
			I _O =4mA; V _{CC} =1.65V	-	-	0.7	V
			I _O =8mA; V _{CC} =2.3V	-	-	0.45	V
			I _O =12mA; V _{CC} =2.7V	-	-	0.6	V
			I _O =24mA; V _{CC} =3.0V	-	-	0.8	V
			I _O =32mA; V _{CC} =4.5V	-	-	0.8	V
I _I	Input leakage current	V _I =5.5V or GND; V _{CC} =0V to 5.5V	-	-	±1	uA	
I _{OFF}	Power-off leakage current	V _I or V _O =5.5V; V _{CC} =0V	-	-	±2	uA	
I _{CC}	Supply current	V _I =5.5V or GND; I _O =0A; V _{CC} =1.65V to 5.5V	-	-	4	uA	
ΔI _{CC}	Additional supply current	Per pin; V _I =V _{CC} -0.6V; I _O =0A; V _{CC} =2.3V to 5.5V	-	-	500	uA	

7.4.3 AC Characteristics 1

$T_{amb} = -40^{\circ}\text{C}$ to $+85^{\circ}\text{C}$, voltages are referenced to GND (ground=0V), unless otherwise specified.

SYMBOL	PARAMETER	CONDITIONS		MIN.	TYP. ⁽¹⁾	MAX.	UNIT
t_{PHL}	A, B to Y propagation delay	See Figure 8-5	$V_{CC}=1.65\text{V to }1.95\text{V}$	-	12.5	18.8	ns
			$V_{CC}=2.3\text{V to }2.7\text{V}$	-	10.5	15.8	ns
			$V_{CC}=2.7\text{V}$	-	10	15	ns
			$V_{CC}=3.0\text{V to }3.6\text{V}$	-	9.5	14.3	ns
			$V_{CC}=4.5\text{V to }5.5\text{V}$	-	9	13.5	ns
t_{PLH}	A, B to Y propagation delay	See Figure 8-5	$V_{CC}=1.65\text{V to }1.95\text{V}$	-	14	21	ns
			$V_{CC}=2.3\text{V to }2.7\text{V}$	-	10	15	ns
			$V_{CC}=2.7\text{V}$	-	9.5	14.3	ns
			$V_{CC}=3.0\text{V to }3.6\text{V}$	-	8.5	12.8	ns
			$V_{CC}=4.5\text{V to }5.5\text{V}$	-	7.5	11.3	ns

(1) Typical values are measured at $T_{amb}=25^{\circ}\text{C}$ and $V_{CC}=1.8\text{V}, 2.5\text{V}, 2.7\text{V}, 3.3\text{V}$ and 5.0V respectively.

7.4.4 AC Characteristics 2

$T_{amb} = -40^{\circ}\text{C}$ to $+125^{\circ}\text{C}$, voltages are referenced to GND (ground=0V), unless otherwise specified.

SYMBOL	PARAMETER	CONDITIONS		MIN.	TYP.	MAX.	UNIT
t_{PHL}	A, B to Y propagation delay	See Figure 8-5	$V_{CC}=1.65\text{V to }1.95\text{V}$	-	-	20.8	ns
			$V_{CC}=2.3\text{V to }2.7\text{V}$	-	-	17.8	ns
			$V_{CC}=2.7\text{V}$	-	-	17	ns
			$V_{CC}=3.0\text{V to }3.6\text{V}$	-	-	16.3	ns
			$V_{CC}=4.5\text{V to }5.5\text{V}$	-	-	15.5	ns
t_{PLH}	A, B to Y propagation delay	See Figure 8-5	$V_{CC}=1.65\text{V to }1.95\text{V}$	-	-	23	ns
			$V_{CC}=2.3\text{V to }2.7\text{V}$	-	-	17	ns
			$V_{CC}=2.7\text{V}$	-	-	16.3	ns
			$V_{CC}=3.0\text{V to }3.6\text{V}$	-	-	14.8	ns
			$V_{CC}=4.5\text{V to }5.5\text{V}$	-	-	13.3	ns

8 Detailed Description

8.1 Overview

The CJ74LVC1G00 provides the single 2-input NAND function.

Input can be driven from either 3.3V or 5V devices. These features allow the use of these devices in a mixed 3.3V and 5V environment.

8.2 Functional Block Diagram

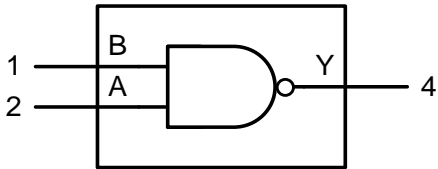

Figure 8-1 Logic symbol



Figure 8-2 IEC logic symbol

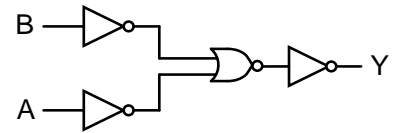

Figure 8-3 Logic diagram

8.3 Function Table⁽¹⁾

INPUT		OUTPUT
A	B	Y
L	L	H
L	H	H
H	L	H
H	H	L

(1) H=HIGH voltage level; L=LOW voltage level.

8.4 Testing Circuit

8.4.1 AC Testing Circuit

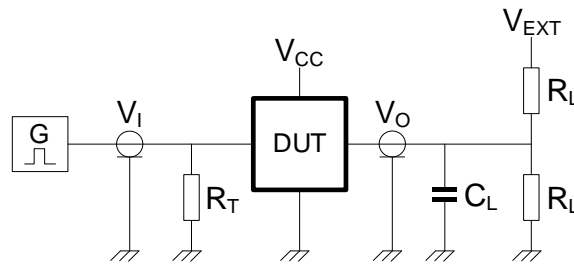

Figure 8-4 Test circuit for measuring switching times

Definitions for test circuit:

R_L =Load resistance.

C_L =Load capacitance including jig and probe capacitance.

R_T =Termination resistance; should be equal to the output impedance Z_o of the pulse generator.

V_{EXT} =External voltage for measuring switching times.

8.4.2 AC Testing Waveforms

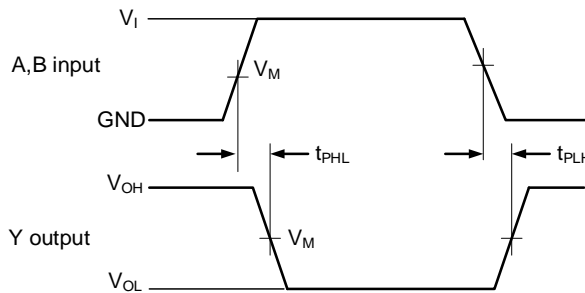

Figure 8-5 The input A, B to output Y propagation delays

8.4.3 Measurement Points

SUPPLY VOLTAGE	INPUT	OUTPUT
V_{CC}	V_M	V_M
1.65V to 1.95V	$0.5 \times V_{CC}$	$0.5 \times V_{CC}$
2.3V to 2.7V	$0.5 \times V_{CC}$	$0.5 \times V_{CC}$
2.7V	1.5V	1.5V
3.0V to 3.6V	1.5V	1.5V
4.5V to 5.5V	$0.5 \times V_{CC}$	$0.5 \times V_{CC}$

8.4.4 Test Data

SUPPLY VOLTAGE	INPUT		LOAD		V_{EXT}
V_{CC}	V_I	$t_r = t_f$	C_L	R_L	t_{PLH}, t_{PHL}
1.65V to 1.95V	V_{CC}	$\leq 3ns$	30pF	1k Ω	Open
2.3V to 2.7V	V_{CC}	$\leq 3ns$	30pF	500 Ω	Open
2.7V	2.7V	$\leq 3ns$	50pF	500 Ω	Open
3.0V to 3.6V	2.7V	$\leq 3ns$	50pF	500 Ω	Open
4.5V to 5.5V	V_{CC}	$\leq 3ns$	50pF	500 Ω	Open

9 Mechanical Information

9.1 SOT-23-5L Mechanical Information

9.1.1 SOT-23-5L Outline Dimensions

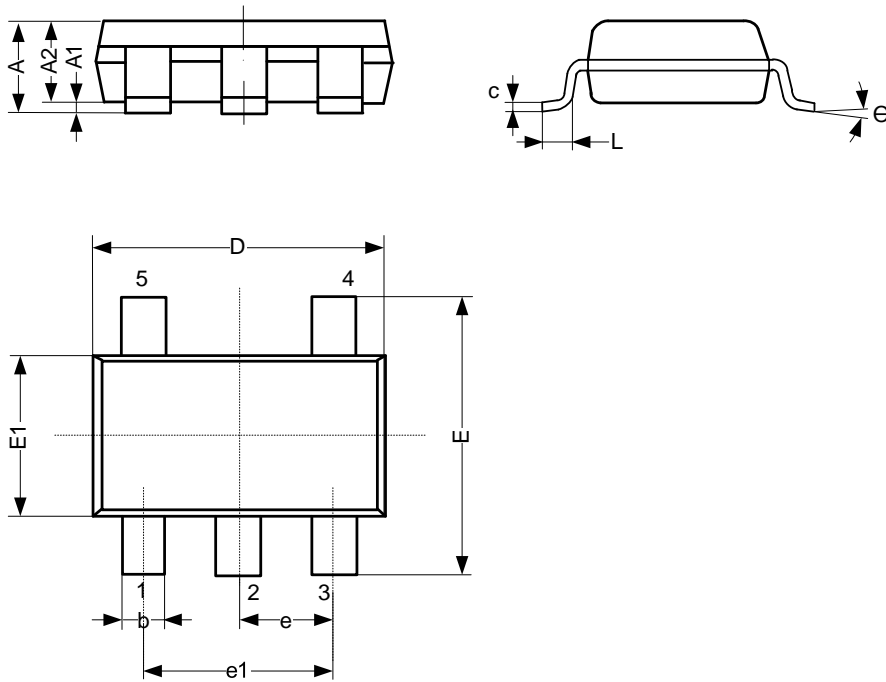

SYMBOL	Dimensions In Millimeters		
	Min.	Typ.	Max.
A	-	-	1.26
A1	0.00	-	0.12
A2	1.00	-	1.20
b	0.30	-	0.50
c	0.10	-	0.20
D	2.82	-	3.02
E	2.60	-	3.00
E1	1.50	-	1.70
e	0.95 BSC		
e1	1.80	-	2.00
L	0.30	-	0.60
Θ	0°	-	8°
Unit: mm			

9.2 SOT-353 Mechanical Information

9.2.1 SOT-353 Outline Dimensions

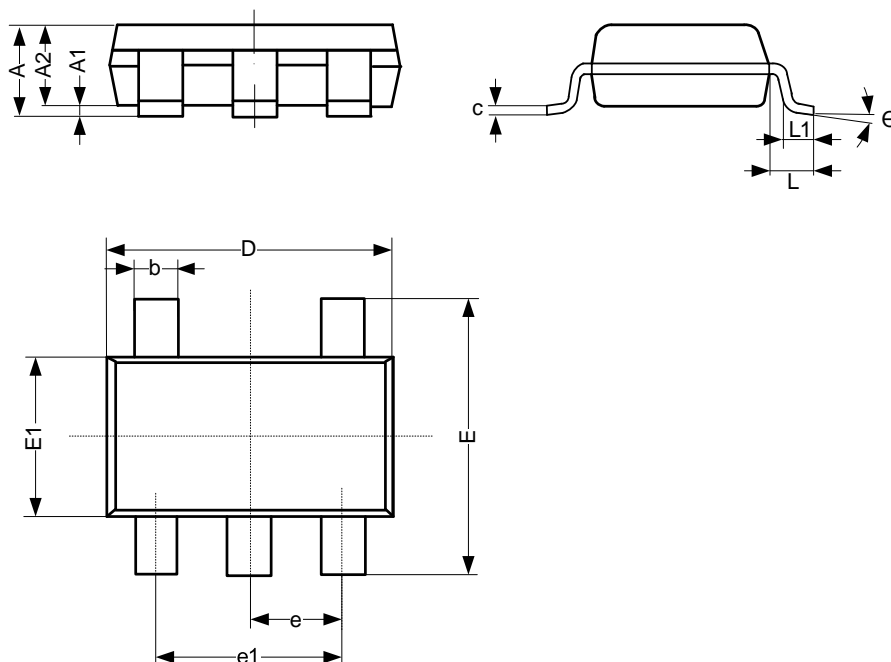

SYMBOL	Dimensions In Millimeters		
	Min.	Typ.	Max.
A	0.90	-	1.10
A1	0.00	-	0.10
A2	0.90	-	1.00
b	0.15	-	0.35
c	0.11	-	0.175
D	2.00	-	2.20
E	2.15	-	2.45
E1	1.15	-	1.35
e	0.65 BSC		
e1	1.20	-	1.40
L	-	0.525	-
L1	0.26	-	0.46
θ	0°	-	8°
Unit: mm			

9.3 DFN1x1-6L Mechanical Information

9.3.1 DFN1x1-6L Outline Dimensions

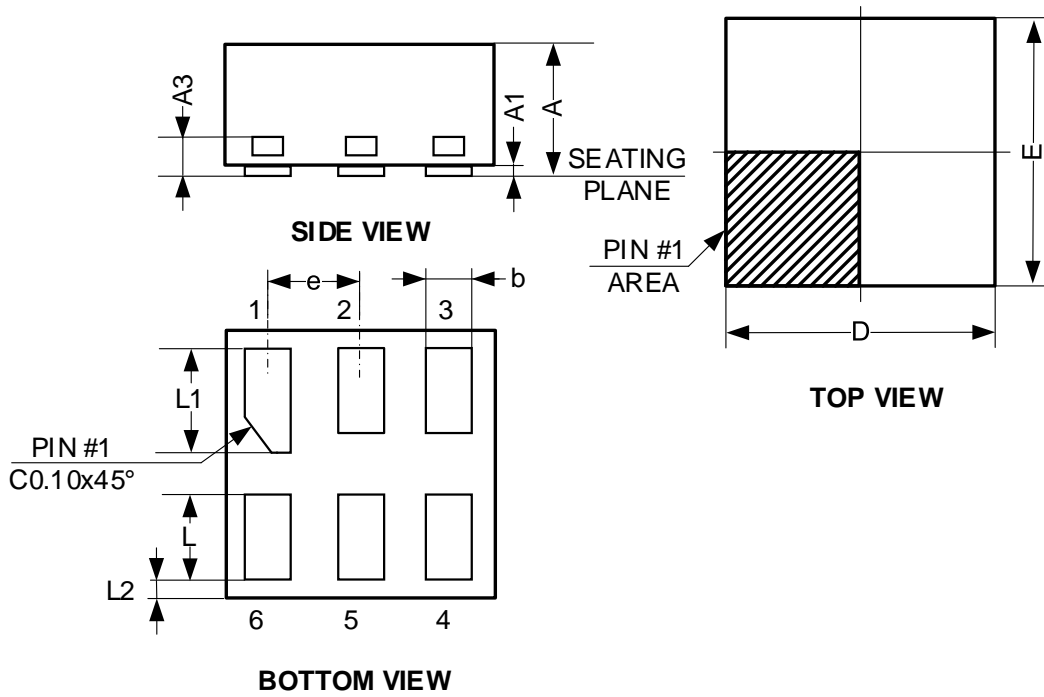

SYMBOL	Dimensions In Millimeters		
	Min.	Typ.	Max.
A	0.41	-	0.50
A1	0.00	-	0.05
A3	-	0.127	-
b	0.11	-	0.21
D	-	1.00	-
E	-	1.00	-
e	0.35 BSC		
L	0.26	-	0.36
L1	0.31	-	0.41
L2	0.02	-	0.12
Unit: mm			

10 Notes and Revision History

10.1 Associated Product Family and Others

To view other products of the same type or IC products of other types, click the official website of JSCJ -- <https://www.jscj-elec.com> for more details.

10.2 Notes

Electrostatic Discharge Caution



This IC may be damaged by ESD. Relevant personnel shall comply with correct installation and use specifications to avoid ESD damage to the IC. If appropriate measures are not taken to prevent ESD damage, the hazards caused by ESD include but are not limited to degradation of integrated circuit performance or complete damage of integrated circuit. For some precision integrated circuits, a very small parameter change may cause the whole device to be inconsistent with its published specifications.

10.3 Revision History

July, 2025: rev - 1.1, Change marking information.

December, 2025: rev - 1.2, Change DFN1x1-6L marking information.

DISCLAIMER

IMPORTANT NOTICE, PLEASE READ CAREFULLY

The information in this data sheet is intended to describe the operation and characteristics of our products. JSCJ has the right to make any modification, enhancement, improvement, correction or other changes to any content in this data sheet, including but not limited to specification parameters, circuit design and application information, without prior notice.

Any person who purchases or uses JSCJ products for design shall: 1. Select products suitable for circuit application and design; 2. Design, verify and test the rationality of circuit design; 3. Procedures to ensure that the design complies with relevant laws and regulations and the requirements of such laws and regulations. JSCJ makes no warranty or representation as to the accuracy or completeness of the information contained in this data sheet and assumes no responsibility for the application or use of any of the products described in this data sheet.

Without the written consent of JSCJ, this product shall not be used in occasions requiring high quality or high reliability, including but not limited to the following occasions: medical equipment, military facilities and aerospace. JSCJ shall not be responsible for casualties or property losses caused by abnormal use or application of this product.

Official Website: www.jscj-elec.com

Copyright © JIANGSU CHANGJING ELECTRONICS TECHNOLOGY CO., LTD