

**Dual Buffer (Open-drain)**

**CJ74LVC2G07 Logic**

**1 Introduction**

The CJ74LVC2G07 provides two non-inverting buffers.

The output of this device is an open drain and can be connected to other open-drain outputs to implement active-LOW wired-OR or active-HIGH wired-AND functions.

Inputs can be driven from either 3.3V or 5V devices. This feature allows the use of this device in a mixed 3.3V and 5V environment.

**2 Available Packages**

PART NUMBER	PACKAGE
CJ74LVC2G07	SOT-23-6L
	SOT-363
	DFN1.45x1-6L
	DFN1x1-6L

**Note:** For all available packages, please refer to the part Orderable Information.

**3 Features**

- Wide supply voltage range from 1.65V to 5.5V
- 5V tolerant inputs for interfacing with 5V logic
- -24mA output drive ( $V_{CC}=3.0V$ )
- CMOS low power consumption
- Specified from -40°C to +125°C

**4 Applications**

- Blu-ray Players and Home Theaters
- DVD Recorders and Players
- Desktops or Notebook PCs
- Digital Video Cameras (DVC)
- Embedded PCs
- GPS: Personal Navigation Devices
- Mobile Phones
- Network Projector Front Ends
- Portable Media Players
- Solid State Drive (SSD): Enterprise
- High-Definition (HDTV)
- Tablet: Enterprise
- Audio Dock: Portable
- DLP Front Projection System

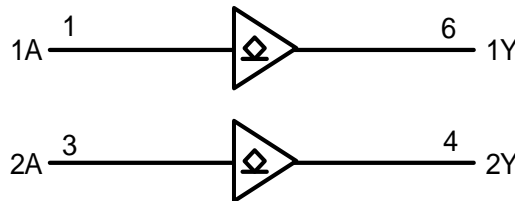

Functional block diagram

**5 Orderable Information**

DEVICE	PACKAGE	OP TEMP	ECO PLAN	MSL	PACKING OPTION	SORT
CJ74LVC2G07M6N	SOT-23-6L	-40~125°C	RoHS & Green	Level 3 168HR	Tape and Reel 3000 Units / Reel	Active
CJ74LVC2G07R6N	SOT-363	-40~125°C	RoHS & Green	Level 3 168HR	Tape and Reel 3000 Units / Reel	Active
CJ74LVC2G07DNN	DFN1.45x1-6L	-40~125°C	RoHS & Green	Level 3 168HR	Tape and Reel 5000 Units / Reel	Active
CJ74LVC2G07DKN	DFN1x1-6L	-40~125°C	RoHS & Green	Level 3 168HR	Tape and Reel 5000 Units / Reel	Active

**Note:**

**ECO PLAN:** For the RoHS and Green certification standards of this product, please refer to the official report provided by JSCJ.

**MSL:** Moisture Sensitivity Level. Determined according to JEDEC industry standard classification.

**SORT:** Specifically defined as follows:

Active: Recommended for new products;

Customized: Products manufactured to meet the specific needs of customers;

Preview: The device has been released and has not been fully mass produced. The sample may or may not be available;

NoRD: It is not recommended to use the device for new design. The device is only produced for the needs of existing customers;

Obsolete: The device has been discontinued.

## 6 Pin Configuration and Marking Information

### 6.1 Pin Configuration

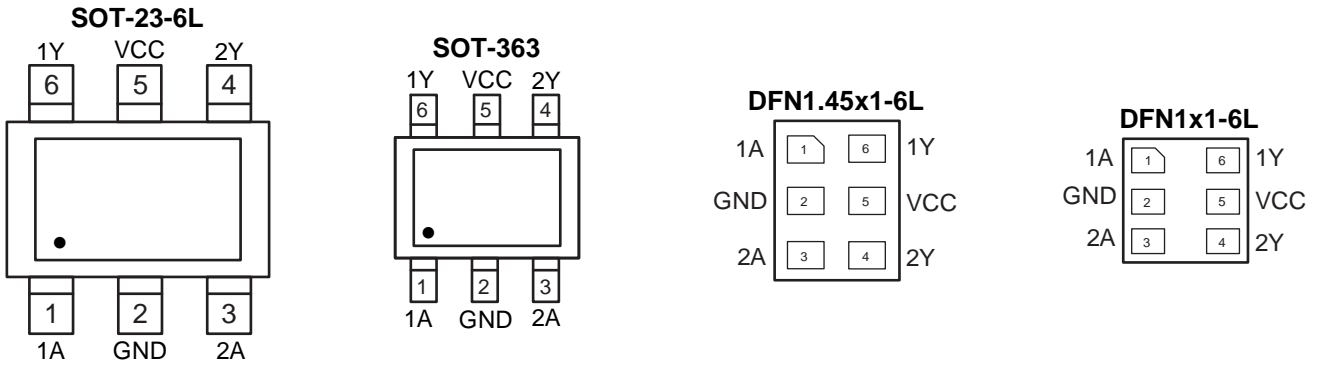

Figure 6-1 Pin configuration

### 6.2 Pin Function

PIN		I/O <sup>(1)</sup>	DESCRIPTION
No.	NAME		
1	1A	I	Data input
2	GND	G	Ground (0V)
3	2A	I	Data input
4	2Y	O	Data output
5	VCC	P	Supply voltage
6	1Y	O	Data output

(1) I-Input, O-Output, P-Power, G-Ground

### 6.3 Marking Information

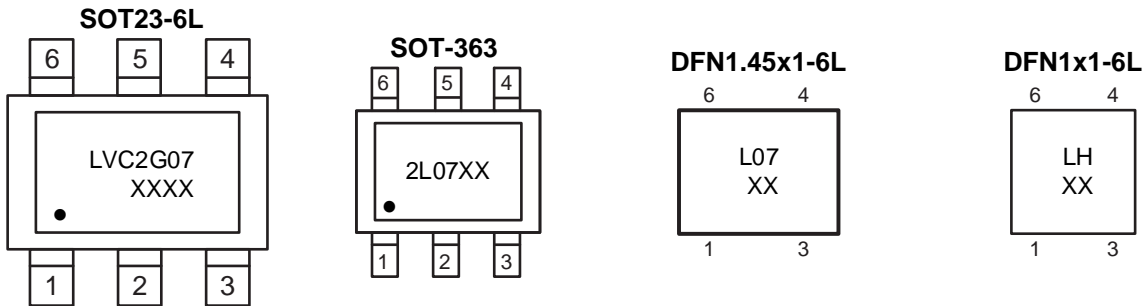

XXXX or XX : Code, indicates weekly record information.

## 7 Specifications

### 7.1 Absolute Maximum Ratings

Voltages are referenced to GND (ground=0V), unless otherwise specified.

SYMBOL	PARAMETER	CONDITIONS	MIN.	MAX.	UNIT
$V_{CC}$	Supply voltage	-	-0.5	+6.5	V
$I_{IK}$	Input clamping current	$V_I < 0V$	-	-50	mA
$V_I$	Input voltage	-	-0.5	+6.5	V
$I_{OK}$	Output clamping current	$V_O < 0V$	-	-50	mA
$V_O$	Output voltage	Active mode	-0.5	+6.5	V
		Power-down mode	-0.5	+6.5	V
$I_O$	Output current	$V_O=0V$ to 6.5V	-	50	mA
$I_{CC}$	Supply current	-	-	100	mA
$I_{GND}$	Ground current	-	-	-100	mA
$T_{stg}$	Storage temperature	-	-65	+150	°C
$P_{tot}$	Total power dissipation	-	-	250	mW
$T_L$	Soldering temperature	10s	-	260	°C

**Note:** When  $V_{CC}=0V$  (Power-down mode), the output voltage can be 5.5V in normal operation.

### 7.2 Recommended Operating Conditions

SYMBOL	PARAMETER	CONDITIONS	MIN.	TYP.	MAX.	UNIT
$V_{CC}$	Supply voltage	-	1.65	-	5.5	V
$V_I$	Input voltage	-	0	-	5.5	V
$V_O$	Output voltage	Active mode	0	-	5.5	V
		Power-down mode; $V_{CC}=0V$	0	-	5.5	V
$T_{amb}$	Ambient temperature	-	-40	-	+125	°C

### 7.3 ESD Ratings

SYMBOL	ESD RATINGS		VALUE	UNIT
$V_{ESD-HBM}$	Electrostatic discharge	Human body model (HBM) <sup>(1)</sup>	±2000	V

(1) JEDEC document JEP155 states that 500-V HBM allows safe manufacturing with a standard ESD control process.

**7.4 Electrical Characteristics**
**7.4.1 DC Characteristics 1**
 $T_{amb} = -40^{\circ}\text{C}$  to  $+85^{\circ}\text{C}$ , voltages are referenced to GND (ground=0V), unless otherwise specified.

SYMBOL	PARAMETER	CONDITIONS	MIN.	TYP.	MAX.	UNIT	
$V_{IH}$	HIGH-level input voltage	$V_{CC}=1.65\text{V}$ to $1.95\text{V}$	$0.65 \times V_{CC}$	-	-	V	
		$V_{CC}=2.3\text{V}$ to $2.7\text{V}$	1.7	-	-	V	
		$V_{CC}=2.7\text{V}$ to $3.6\text{V}$	2.0	-	-	V	
		$V_{CC}=4.5\text{V}$ to $5.5\text{V}$	$0.7 \times V_{CC}$	-	-	V	
$V_{IL}$	LOW-level input voltage	$V_{CC}=1.65\text{V}$ to $1.95\text{V}$	-	-	$0.35 \times V_{CC}$	V	
		$V_{CC}=2.3\text{V}$ to $2.7\text{V}$	-	-	0.7	V	
		$V_{CC}=2.7\text{V}$ to $3.6\text{V}$	-	-	0.8	V	
		$V_{CC}=4.5\text{V}$ to $5.5\text{V}$	-	-	$0.3 \times V_{CC}$	V	
$V_{OL}$	LOW-level output voltage	$V_I = V_{IH}$ or $V_{IL}$	$I_o=100\mu\text{A}$ ; $V_{CC}=1.65\text{V}$ to $5.5\text{V}$	-	-	0.10	V
			$I_o=4\text{mA}$ ; $V_{CC}=1.65\text{V}$	-	-	0.45	V
			$I_o=8\text{mA}$ ; $V_{CC}=2.3\text{V}$	-	-	0.30	V
			$I_o=12\text{mA}$ ; $V_{CC}=2.7\text{V}$	-	-	0.40	V
			$I_o=24\text{mA}$ ; $V_{CC}=3.0\text{V}$	-	-	0.55	V
			$I_o=32\text{mA}$ ; $V_{CC}=4.5\text{V}$	-	-	0.55	V
$I_I$	Input leakage current	$V_I=5.5\text{V}$ or GND; $V_{CC}=0\text{V}$ to $5.5\text{V}$	-	-	$\pm 1$	$\mu\text{A}$	
$I_{OZ}$	OFF-state output current	$V_I=V_{IH}$ or $V_{IL}$ ; $V_O=V_{CC}$ or GND; $V_{CC}=5.5\text{V}$	-	-	$\pm 2$	$\mu\text{A}$	
$I_{OFF}$	Power-off leakage current	$V_I$ or $V_O=5.5\text{V}$ ; $V_{CC}=0\text{V}$	-	-	$\pm 2$	$\mu\text{A}$	
$I_{CC}$	Supply current	$V_I=5.5\text{V}$ or GND; $I_o=0\text{A}$ ; $V_{CC}=1.65\text{V}$ to $5.5\text{V}$	-	-	4	$\mu\text{A}$	
$\Delta I_{CC}$	Additional supply current	Per pin; $V_I=V_{CC}-0.6\text{V}$ ; $I_o=0\text{A}$ ; $V_{CC}=2.3\text{V}$ to $5.5\text{V}$	-	-	500	$\mu\text{A}$	
$C_i$	Input capacitance	-	-	2.5	-	pF	

**Note:** All typical values are measured at  $V_{CC}=3.3\text{V}$  and  $T_{amb}=25^{\circ}\text{C}$ .

**7.4.2 DC Characteristics 2**

$T_{amb} = -40^{\circ}\text{C}$  to  $+125^{\circ}\text{C}$ , voltages are referenced to GND (ground=0V), unless otherwise specified.

SYMBOL	PARAMETER	CONDITIONS	MIN.	TYP.	MAX.	UNIT	
$V_{IH}$	HIGH-level input voltage	$V_{CC}=1.65\text{V}$ to $1.95\text{V}$	$0.65 \times V_{CC}$	-	-	V	
		$V_{CC}=2.3\text{V}$ to $2.7\text{V}$	1.7	-	-	V	
		$V_{CC}=2.7\text{V}$ to $3.6\text{V}$	2.0	-	-	V	
		$V_{CC}=4.5\text{V}$ to $5.5\text{V}$	$0.7 \times V_{CC}$	-	-	V	
$V_{IL}$	LOW-level input voltage	$V_{CC}=1.65\text{V}$ to $1.95\text{V}$	-	-	$0.35 \times V_{CC}$	V	
		$V_{CC}=2.3\text{V}$ to $2.7\text{V}$	-	-	0.7	V	
		$V_{CC}=2.7\text{V}$ to $3.6\text{V}$	-	-	0.8	V	
		$V_{CC}=4.5\text{V}$ to $5.5\text{V}$	-	-	$0.3 \times V_{CC}$	V	
$V_{OL}$	LOW-level output voltage	$V_I = V_{IH}$ or $V_{IL}$	$I_o=100\mu\text{A}$ ; $V_{CC}=1.65\text{V}$ to $5.5\text{V}$	-	-	0.10	V
			$I_o=4\text{mA}$ ; $V_{CC}=1.65\text{V}$	-	-	0.70	V
			$I_o=8\text{mA}$ ; $V_{CC}=2.3\text{V}$	-	-	0.45	V
			$I_o=12\text{mA}$ ; $V_{CC}=2.7\text{V}$	-	-	0.60	V
			$I_o=24\text{mA}$ ; $V_{CC}=3.0\text{V}$	-	-	0.80	V
			$I_o=32\text{mA}$ ; $V_{CC}=4.5\text{V}$	-	-	0.80	V
$I_I$	Input leakage current	$V_I=5.5\text{V}$ or GND; $V_{CC}=0\text{V}$ to $5.5\text{V}$	-	-	$\pm 1$	$\mu\text{A}$	
$I_{OZ}$	OFF-state output current	$V_I=V_{IH}$ or $V_{IL}$ ; $V_O=V_{CC}$ or GND; $V_{CC}=5.5\text{V}$	-	-	$\pm 2$	$\mu\text{A}$	
$I_{OFF}$	Power-off leakage current	$V_I$ or $V_O=5.5\text{V}$ ; $V_{CC}=0\text{V}$	-	-	$\pm 2$	$\mu\text{A}$	
$I_{CC}$	Supply current	$V_I=5.5\text{V}$ or GND; $I_o=0\text{A}$ ; $V_{CC}=1.65\text{V}$ to $5.5\text{V}$	-	-	4	$\mu\text{A}$	
$\Delta I_{CC}$	Additional supply current	Per pin; $V_I=V_{CC}-0.6\text{V}$ ; $I_o=0\text{A}$ ; $V_{CC}=2.3\text{V}$ to $5.5\text{V}$	-	-	500	$\mu\text{A}$	

**7.4.3 AC Characteristics 1**

$T_{amb} = -40^{\circ}\text{C}$  to  $+85^{\circ}\text{C}$ , voltages are referenced to GND (ground=0V), unless otherwise specified.

SYMBOL	PARAMETER	CONDITIONS	MIN.	TYP. <sup>(1)</sup>	MAX.	UNIT	
$t_{PLZ}$ , $t_{PZL}$	nA to nY propagation delay	See Figure 8-5	$V_{CC}=1.65\text{V to }1.95\text{V}$	-	12.3	18.4	ns
			$V_{CC}=2.3\text{V to }2.7\text{V}$	-	8.4	12.6	ns
			$V_{CC}=2.7\text{V}$	-	8.1	12.1	ns
			$V_{CC}=3.0\text{V to }3.6\text{V}$	-	9.1	13.7	ns
			$V_{CC}=4.5\text{V to }5.5\text{V}$	-	5.3	7.9	ns

(1) Typical values are measured at  $T_{amb}=25^{\circ}\text{C}$  and  $V_{CC}=1.8\text{V}$ ,  $2.5\text{V}$ ,  $2.7\text{V}$ ,  $3.3\text{V}$  and  $5.0\text{V}$  respectively.

**7.4.4 AC Characteristics 2**

$T_{amb} = -40^{\circ}\text{C}$  to  $+125^{\circ}\text{C}$ , voltages are referenced to GND (ground=0V), unless otherwise specified.

SYMBOL	PARAMETER	CONDITIONS	MIN.	TYP.	MAX.	UNIT	
$t_{PLZ}$ , $t_{PZL}$	nA to nY propagation delay	See Figure 8-5	$V_{CC}=1.65\text{V to }1.95\text{V}$	-	-	23.0	ns
			$V_{CC}=2.3\text{V to }2.7\text{V}$	-	-	16.1	ns
			$V_{CC}=2.7\text{V}$	-	-	15.2	ns
			$V_{CC}=3.0\text{V to }3.6\text{V}$	-	-	17.3	ns
			$V_{CC}=4.5\text{V to }5.5\text{V}$	-	-	10.0	ns

## 8 Detailed Description

### 8.1 Overview

The CJ74LVC2G07 provides two non-inverting buffers.

The output of this device is an open drain and can be connected to other open-drain outputs to implement active-LOW wired-OR or active-HIGH wired-AND functions.

Inputs can be driven from either 3.3V or 5V devices. This feature allows the use of this device in a mixed 3.3V and 5V environment.

### 8.2 Functional Block Diagram

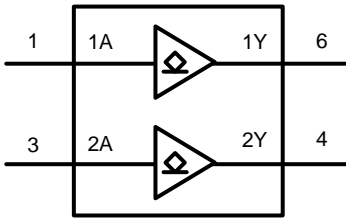

Figure 8-1 Logic symbol

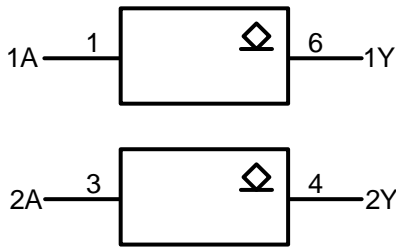

Figure 8-2 IEC logic symbol

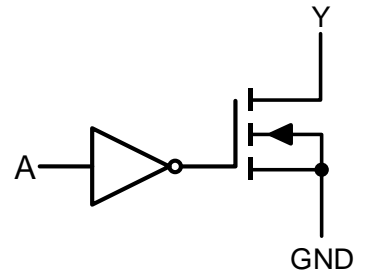

Figure 8-3 Logic diagram

### 8.3 Function Table<sup>(1)</sup>

INPUT	OUTPUT
nA	nY
L	L
H	Z

(1) H=HIGH voltage level; L=LOW voltage level; Z=high-impedance OFF-state.

8.4 Testing Circuit

8.4.1 AC Testing Circuit

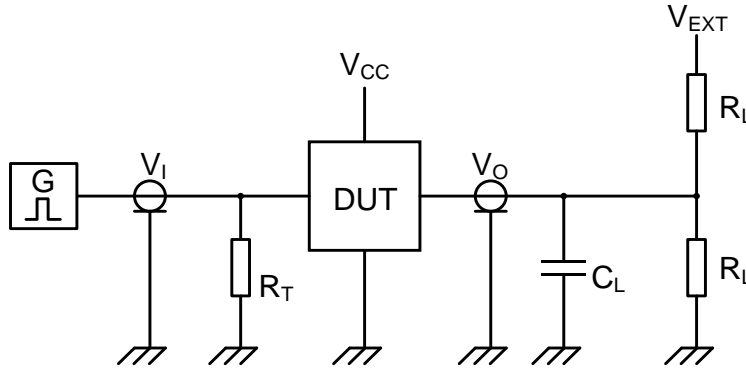

Figure 8-4 Test circuit for measuring switching times

Definitions for test circuit:

$R_L$ =Load resistance.

$C_L$ =Load capacitance including jig and probe capacitance.

$R_T$ =Termination resistance; should be equal to the output impedance  $Z_o$  of the pulse generator.

$V_{EXT}$ =External voltage for measuring switching times.

8.4.2 AC Testing Waveforms

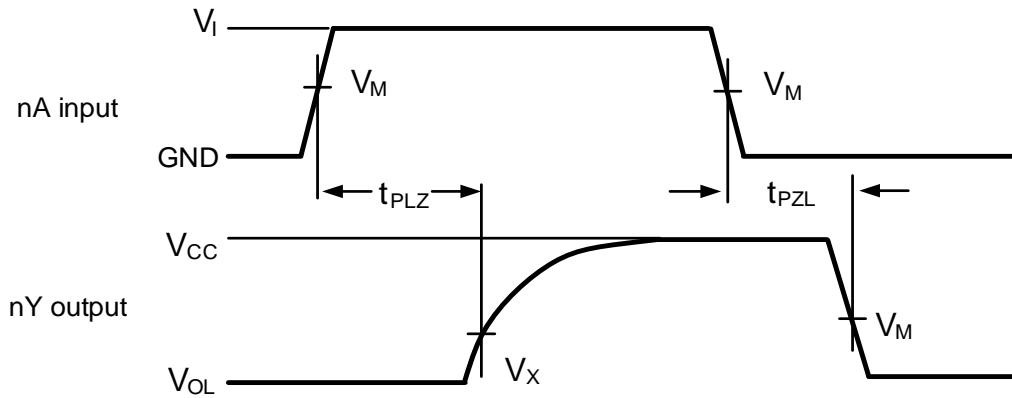

Figure 8-5 The input nA to output nY propagation delays

**8.4.3 Measurement Points**

SUPPLY VOLTAGE	INPUT	OUTPUT	
$V_{CC}$	$V_M$	$V_M$	$V_X$
1.65V to 1.95V	$0.5 \times V_{CC}$	$0.5 \times V_{CC}$	$V_{OL} + 0.15V$
2.3V to 2.7V	$0.5 \times V_{CC}$	$0.5 \times V_{CC}$	$V_{OL} + 0.15V$
2.7V	1.5V	1.5V	$V_{OL} + 0.3V$
3.0V to 3.6V	1.5V	1.5V	$V_{OL} + 0.3V$
4.5V to 5.5V	$0.5 \times V_{CC}$	$0.5 \times V_{CC}$	$V_{OL} + 0.3V$

**8.4.4 Test Data**

SUPPLY VOLTAGE	INPUT		LOAD		$V_{EXT}$
$V_{CC}$	$V_I$	$t_r = t_f$	$C_L$	$R_L$	$t_{PZL}, t_{PLZ}$
1.65V to 1.95V	$V_{CC}$	$\leq 3ns$	30pF	1k $\Omega$	$2 \times V_{CC}$
2.3V to 2.7V	$V_{CC}$	$\leq 3ns$	30pF	500 $\Omega$	$2 \times V_{CC}$
2.7V	2.7V	$\leq 3ns$	50pF	500 $\Omega$	6V
3.0V to 3.6V	2.7V	$\leq 3ns$	50pF	500 $\Omega$	6V
4.5V to 5.5V	$V_{CC}$	$\leq 3ns$	50pF	500 $\Omega$	$2 \times V_{CC}$

9 Mechanical Information

9.1 SOT-23-6L Mechanical Information

9.1.1 SOT-23-6L Outline Dimensions

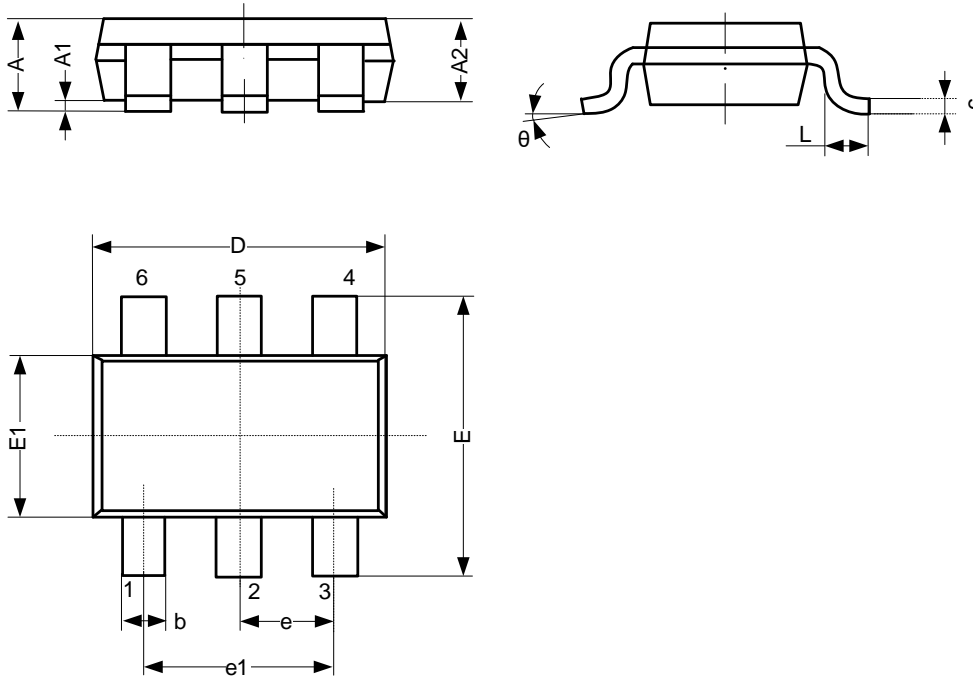

SYMBOL	Dimensions In Millimeters		
	Min.	Typ.	Max.
A	-	-	1.25
A1	0.00	-	0.12
A2	1.00	-	1.20
b	0.30	-	0.50
c	0.10	-	0.20
D	2.82	-	3.02
E	2.60	-	3.00
E1	1.50	-	1.70
e	0.95 BSC		
e1	1.80	-	2.00
L	0.30	-	0.60
θ	0°	-	8°
Unit: mm			

9.2 SOT-363 Mechanical Information

9.2.1 SOT-363 Outline Dimensions

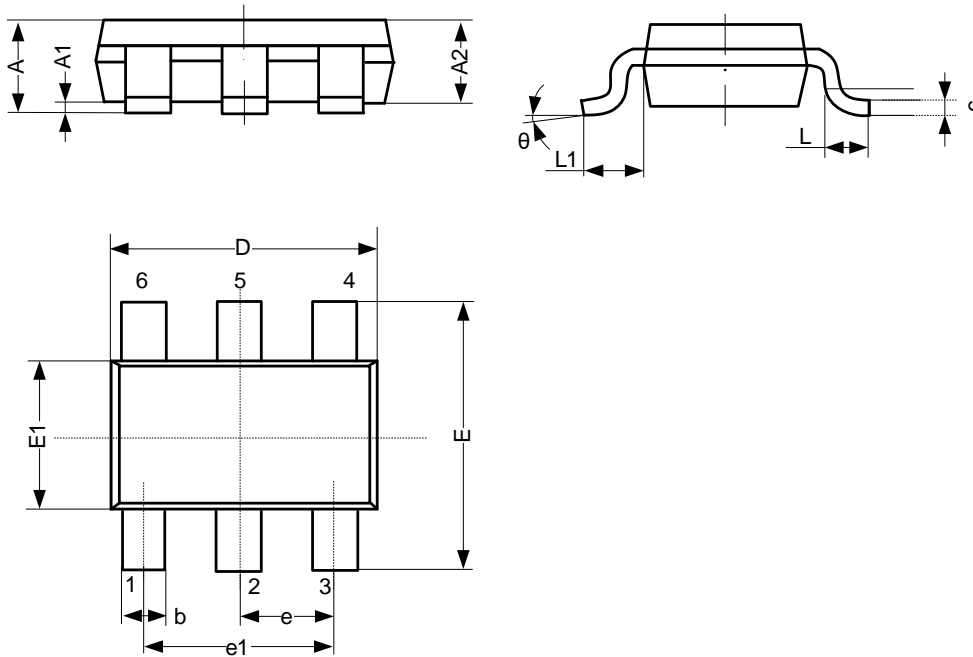

SYMBOL	Dimensions In Millimeters		
	Min.	Typ.	Max.
A	0.90	-	1.10
A1	0.00	-	0.10
A2	0.90	-	1.00
b	0.15	-	0.35
c	0.11	-	0.175
D	2.00	-	2.20
E	2.15	-	2.45
E1	1.15	-	1.35
e	0.65 BSC		
e1	1.20	-	1.40
L	0.26	-	0.46
L1	-	0.525	-
$\theta$	0°	-	8°
Unit: mm			

9.3 DFN1.45x1-6L Mechanical Information

9.3.1 DFN1.45x1-6L Outline Dimensions

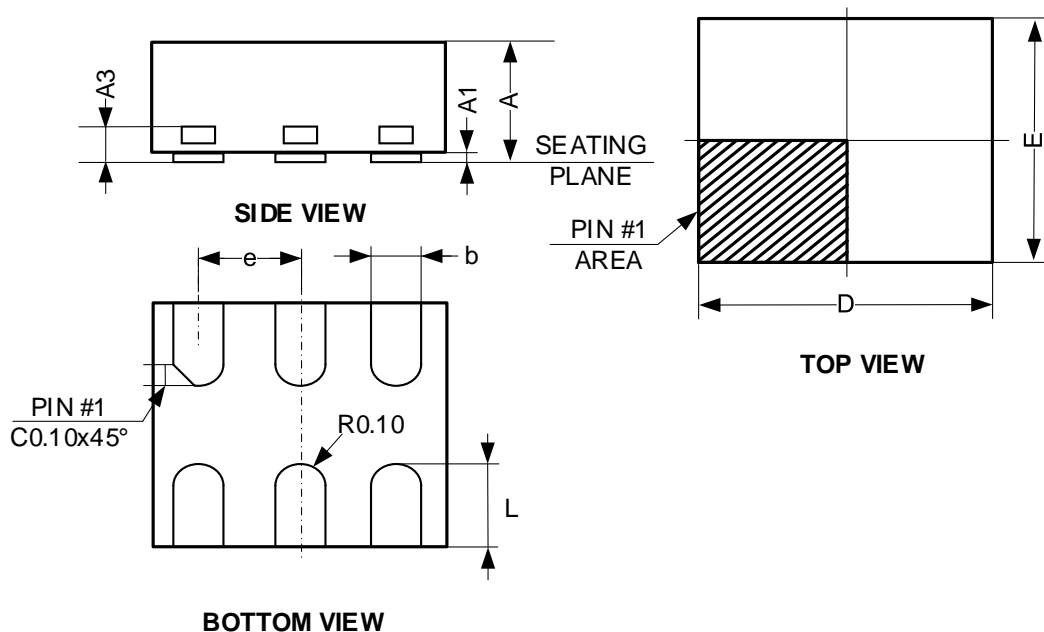

SYMBOL	Dimensions In Millimeters		
	Min.	Typ.	Max.
A	0.51	-	0.60
A1	0.00	-	0.05
A3	-	0.15	-
b	0.15	-	0.25
D	-	1.45	-
E	-	1.00	-
e	0.50 BSC		
L	0.25	-	0.45
Unit: mm			

9.4 DFN1x1-6L Mechanical Information

9.4.1 DFN1x1-6L Outline Dimensions

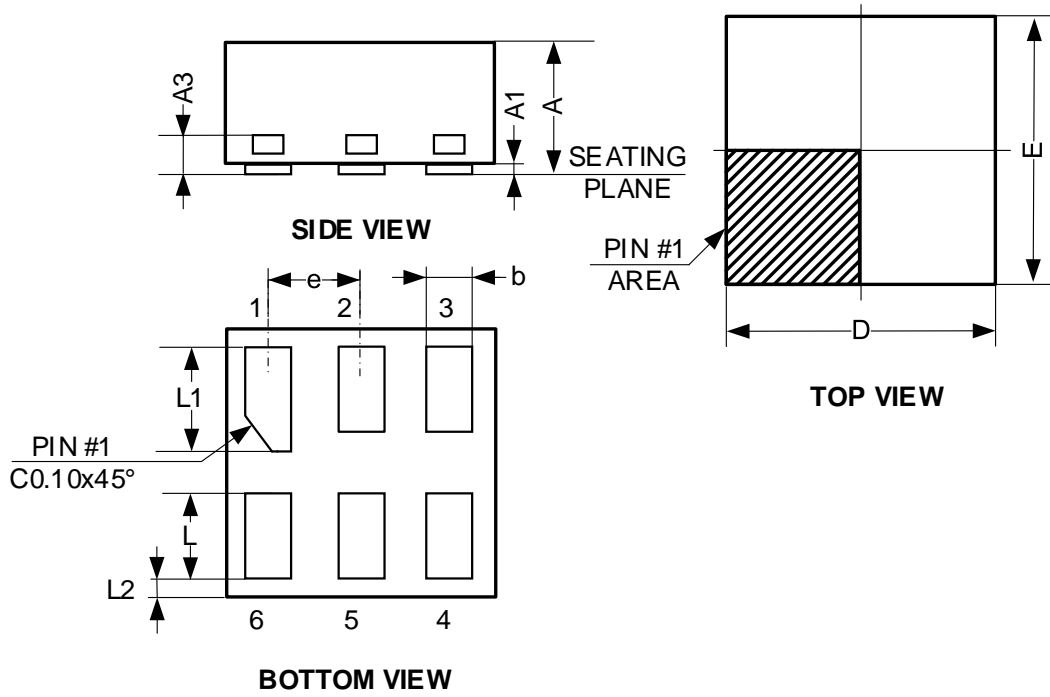

SYMBOL	Dimensions In Millimeters		
	Min.	Typ.	Max.
A	0.41	-	0.50
A1	0.00	-	0.05
A3	-	0.127	-
b	0.11	-	0.21
D	-	1.00	-
E	-	1.00	-
e	0.35 BSC		
L	0.26	-	0.36
L1	0.31	-	0.41
L2	0.02	-	0.12
Unit: mm			

## 10 Notes and Revision History

### 10.1 Associated Product Family and Others

To view other products of the same type or IC products of other types, click the official website of JSCJ -- <https://www.jscj-elec.com> for more details.

### 10.2 Notes

#### Electrostatic Discharge Caution



This IC may be damaged by ESD. Relevant personnel shall comply with correct installation and use specifications to avoid ESD damage to the IC. If appropriate measures are not taken to prevent ESD damage, the hazards caused by ESD include but are not limited to degradation of integrated circuit performance or complete damage of integrated circuit. For some precision integrated circuits, a very small parameter change may cause the whole device to be inconsistent with its published specifications.

### 10.3 Revision History

December, 2025: rev - 1.1, Change DFN1x1-6L marking information.

# DISCLAIMER

## IMPORTANT NOTICE, PLEASE READ CAREFULLY

The information in this data sheet is intended to describe the operation and characteristics of our products. JSCJ has the right to make any modification, enhancement, improvement, correction or other changes to any content in this data sheet, including but not limited to specification parameters, circuit design and application information, without prior notice.

Any person who purchases or uses JSCJ products for design shall: 1. Select products suitable for circuit application and design; 2. Design, verify and test the rationality of circuit design; 3. Procedures to ensure that the design complies with relevant laws and regulations and the requirements of such laws and regulations. JSCJ makes no warranty or representation as to the accuracy or completeness of the information contained in this data sheet and assumes no responsibility for the application or use of any of the products described in this data sheet.

Without the written consent of JSCJ, this product shall not be used in occasions requiring high quality or high reliability, including but not limited to the following occasions: medical equipment, military facilities and aerospace. JSCJ shall not be responsible for casualties or property losses caused by abnormal use or application of this product.

Official Website: [www.jscj-elec.com](http://www.jscj-elec.com)

Copyright © JIANGSU CHANGJING ELECTRONICS TECHNOLOGY CO., LTD