

Dual 2-input AND Gate

CJ74LVC2G08 Logic

1 Introduction

The CJ74LVC2G08 provides a 2-input AND gate function. Inputs can be driven from either 3.3V or 5V devices. This feature allows the use of the CJ74LVC2G08 as a translator in a mixed 3.3V and 5V environment.

2 Available Packages

PART NUMBER	PACKAGE
CJ74LVC2G08	TSSOP8
	VSSOP8

Note: For all available packages, please refer to the part Orderable Information.

3 Features

- Wide supply voltage range from 1.65V to 5.5V
- 5V tolerant outputs for interfacing with 5V logic
- $\pm 24\text{mA}$ output drive ($V_{CC}=3.0\text{V}$)
- CMOS low power consumption
- Specified from -40°C to $+125^{\circ}\text{C}$

4 Applications

- IP Phones: Wired and Wireless
- Optical Networking: EPON and Video Over Fiber
- Point-to-Point Microwave Backhaul
- Power: Telecom DC/DC Module: Analog
- Power: Telecom DC/DC Module: Digital
- Private Branch Exchange (PBX)
- Telecom Shelter: Power Distribution Unit (PDU)
- Vector Signal Analyzers and Generators
- Wireless Communications Testers
- Wireless Repeaters
- xDSL Modem/DSLAM

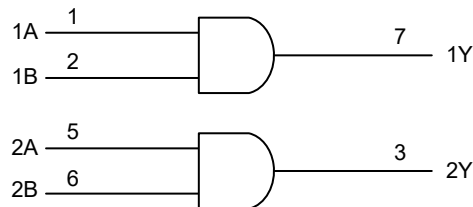

Functional diagram

5 Orderable Information

DEVICE	PACKAGE	OP TEMP	ECO PLAN	MSL	PACKING OPTION	SORT
CJ74LVC2G08BAN	TSSOP8	-40~125°C	RoHS & Green	Level 3 168HR	Tape and Reel 3000 Units / Reel	Active
CJ74LVC2G08VAN	VSSOP8	-40~125°C	RoHS & Green	Level 3 168HR	Tape and Reel 3000 Units / Reel	Active

Note:

ECO PLAN: For the RoHS and Green certification standards of this product, please refer to the official report provided by JSCJ.

MSL: Moisture Sensitivity Level. Determined according to JEDEC industry standard classification.

SORT: Specifically defined as follows:

Active: Recommended for new products;

Customized: Products manufactured to meet the specific needs of customers;

Preview: The device has been released and has not been fully mass produced. The sample may or may not be available;

NoRD: It is not recommended to use the device for new design. The device is only produced for the needs of existing customers;

Obsolete: The device has been discontinued.

6 Pin Configuration and Marking Information

6.1 Pin Configuration

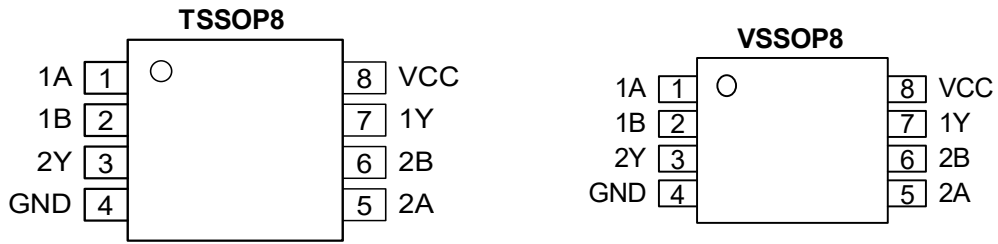

Figure 6-1 Pin configuration

6.2 Pin Function

PIN		I/O ⁽¹⁾	DESCRIPTION
No.	NAME		
1	1A	I	Data input
2	1B	I	Data input
3	2Y	O	Data output
4	GND	G	Ground (0V)
5	2A	I	Data input
6	2B	I	Data input
7	1Y	O	Data output
8	VCC	P	Supply voltage

(1) I-Input, O-Output, P-Power, G-Ground

6.3 Marking Information

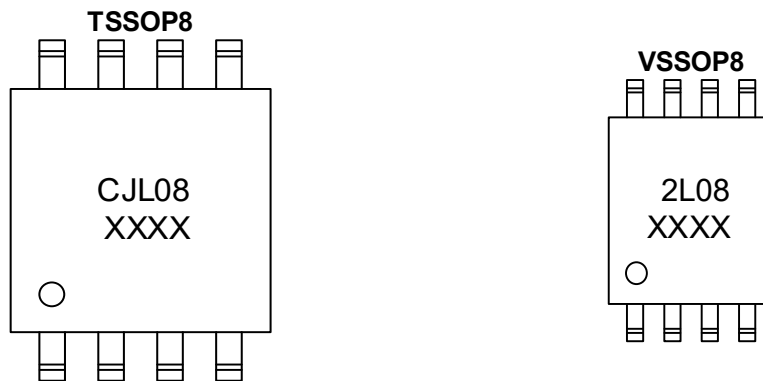

XXXX: Code, indicates weekly record information.

7 Specifications

7.1 Absolute Maximum Ratings

Voltages are referenced to GND (ground=0V), unless otherwise specified.

SYMBOL	PARAMETER	CONDITIONS	MIN.	MAX.	UNIT
V_{CC}	Supply voltage	-	-0.5	+6.5	V
V_I	Input voltage	-	-0.5	+6.5	V
V_O	Output voltage	Active mode	-0.5	$V_{CC}+0.5$	V
		Power-down mode	-0.5	+6.5	V
I_{IK}	Input clamping current	$V_I < 0V$	-50	-	mA
I_{OK}	Output clamping current	$V_O > V_{CC}$ or $V_O < 0V$	-	± 50	mA
I_O	Output current	$V_O=0V$ to V_{CC}	-	± 50	mA
I_{CC}	Supply current	-	-	100	mA
I_{GND}	Ground current	-	-100	-	mA
T_{stg}	Storage temperature	-	-65	+150	°C
P_{tot}	Total power dissipation	-	-	300	mW
T_L	Soldering temperature	10s	-	260	°C

Note: When $V_{CC}=0V$ (Power-down mode), the output voltage can be 5.5V in normal operation.

7.2 Recommended Operating Conditions

SYMBOL	PARAMETER	CONDITIONS	MIN.	TYP.	MAX.	UNIT
V_{CC}	Supply voltage	-	1.65	-	5.5	V
V_I	Input voltage	-	0	-	5.5	V
V_O	Output voltage	Active mode	0	-	V_{CC}	V
		Power-down mode	0	-	5.5	V
T_{amb}	Ambient temperature	-	-40	-	+125	°C

7.3 ESD Ratings

SYMBOL	ESD RATINGS		VALUE	UNIT
$V_{ESD-HBM}$	Electrostatic discharge	Human body model (HBM) ⁽¹⁾	± 2000	V

(1) JEDEC document JEP155 states that 500-V HBM allows safe manufacturing with a standard ESD control process.

7.4 Electrical Characteristics
7.4.1 DC Characteristics 1
 $T_{amb} = -40^{\circ}\text{C}$ to $+85^{\circ}\text{C}$, voltages are referenced to GND (ground=0V), unless otherwise specified.

SYMBOL	PARAMETER	CONDITIONS	MIN.	TYP.	MAX.	UNIT	
V_{IH}	HIGH-level input voltage	$V_{CC}=1.65\text{V}$ to 1.95V	$0.65 \times V_{CC}$	-	-	V	
		$V_{CC}=2.3\text{V}$ to 2.7V	1.7	-	-	V	
		$V_{CC}=2.7\text{V}$ to 3.6V	2.0	-	-	V	
		$V_{CC}=4.5\text{V}$ to 5.5V	$0.7 \times V_{CC}$	-	-	V	
V_{IL}	LOW-level input voltage	$V_{CC}=1.65\text{V}$ to 1.95V	-	-	$0.35 \times V_{CC}$	V	
		$V_{CC}=2.3\text{V}$ to 2.7V	-	-	0.7	V	
		$V_{CC}=2.7\text{V}$ to 3.6V	-	-	0.8	V	
		$V_{CC}=4.5\text{V}$ to 5.5V	-	-	$0.3 \times V_{CC}$	V	
V_{OH}	HIGH-level output voltage	$V_I = V_{IH}$ or V_{IL}	$I_O = -100\mu\text{A}$; $V_{CC}=1.65\text{V}$ to 5.5V	$V_{CC}-0.1$	-	-	V
			$I_O = -4\text{mA}$; $V_{CC}=1.65\text{V}$	1.2	1.53	-	V
			$I_O = -8\text{mA}$; $V_{CC}=2.3\text{V}$	1.9	2.13	-	V
			$I_O = -12\text{mA}$; $V_{CC}=2.7\text{V}$	2.2	2.50	-	V
			$I_O = -24\text{mA}$; $V_{CC}=3.0\text{V}$	2.3	2.60	-	V
			$I_O = -32\text{mA}$; $V_{CC}=4.5\text{V}$	3.8	4.10	-	V
V_{OL}	LOW-level output voltage	$V_I = V_{IH}$ or V_{IL}	$I_O = 100\mu\text{A}$; $V_{CC}=1.65\text{V}$ to 5.5V	-	-	0.10	V
			$I_O = 4\text{mA}$; $V_{CC}=1.65\text{V}$	-	0.08	0.45	V
			$I_O = 8\text{mA}$; $V_{CC}=2.3\text{V}$	-	0.14	0.30	V
			$I_O = 12\text{mA}$; $V_{CC}=2.7\text{V}$	-	0.19	0.40	V
			$I_O = 24\text{mA}$; $V_{CC}=3.0\text{V}$	-	0.37	0.55	V
			$I_O = 32\text{mA}$; $V_{CC}=4.5\text{V}$	-	0.43	0.55	V
I_I	Input leakage current	$V_I = 5.5\text{V}$ or GND; $V_{CC}=0\text{V}$ to 5.5V	-	-	± 1	μA	
I_{OFF}	Power-off leakage current	V_I or $V_O = 5.5\text{V}$; $V_{CC}=0\text{V}$	-	-	± 2	μA	
I_{CC}	Supply current	$V_I = 5.5\text{V}$ or GND; $I_O = 0\text{A}$; $V_{CC}=1.65\text{V}$ to 5.5V	-	-	4	μA	
ΔI_{CC}	Additional supply current	Per pin; $V_I = V_{CC}-0.6\text{V}$; $I_O = 0\text{A}$; $V_{CC}=2.3\text{V}$ to 5.5V	-	-	500	μA	
C_I	Input capacitance	-	-	2.5	-	pF	

Note: All typical values are measured at $T_{amb} = 25^{\circ}\text{C}$.

7.4.2 DC Characteristics 2

$T_{amb} = -40^{\circ}\text{C}$ to $+125^{\circ}\text{C}$, voltages are referenced to GND (ground=0V), unless otherwise specified.

SYMBOL	PARAMETER	CONDITIONS	MIN.	TYP.	MAX.	UNIT	
V_{IH}	HIGH-level input voltage	$V_{CC}=1.65\text{V to }1.95\text{V}$	$0.65 \times V_{CC}$	-	-	V	
		$V_{CC}=2.3\text{V to }2.7\text{V}$	1.7	-	-	V	
		$V_{CC}=2.7\text{V to }3.6\text{V}$	2.0	-	-	V	
		$V_{CC}=4.5\text{V to }5.5\text{V}$	$0.7 \times V_{CC}$	-	-	V	
V_{IL}	LOW-level input voltage	$V_{CC}=1.65\text{V to }1.95\text{V}$	-	-	$0.35 \times V_{CC}$	V	
		$V_{CC}=2.3\text{V to }2.7\text{V}$	-	-	0.7	V	
		$V_{CC}=2.7\text{V to }3.6\text{V}$	-	-	0.8	V	
		$V_{CC}=4.5\text{V to }5.5\text{V}$	-	-	$0.3 \times V_{CC}$	V	
V_{OH}	HIGH-level output voltage	$V_I = V_{IH}$ or V_{IL}	$I_o = -100\mu\text{A}; V_{CC}=1.65\text{V to }5.5\text{V}$	$V_{CC}-0.1$	-	-	V
			$I_o = -4\text{mA}; V_{CC}=1.65\text{V}$	0.95	-	-	V
			$I_o = -8\text{mA}; V_{CC}=2.3\text{V}$	1.7	-	-	V
			$I_o = -12\text{mA}; V_{CC}=2.7\text{V}$	1.9	-	-	V
			$I_o = -24\text{mA}; V_{CC}=3.0\text{V}$	2.0	-	-	V
			$I_o = -32\text{mA}; V_{CC}=4.5\text{V}$	3.4	-	-	V
V_{OL}	LOW-level output voltage	$V_I = V_{IH}$ or V_{IL}	$I_o = 100\mu\text{A}; V_{CC}=1.65\text{V to }5.5\text{V}$	-	-	0.10	V
			$I_o = 4\text{mA}; V_{CC}=1.65\text{V}$	-	-	0.70	V
			$I_o = 8\text{mA}; V_{CC}=2.3\text{V}$	-	-	0.45	V
			$I_o = 12\text{mA}; V_{CC}=2.7\text{V}$	-	-	0.60	V
			$I_o = 24\text{mA}; V_{CC}=3.0\text{V}$	-	-	0.80	V
			$I_o = 32\text{mA}; V_{CC}=4.5\text{V}$	-	-	0.80	V
I_I	Input leakage current	$V_I=5.5\text{V}$ or GND; $V_{CC}=0\text{V to }5.5\text{V}$	-	-	± 1	μA	
I_{OFF}	Power-off leakage current	V_I or $V_O=5.5\text{V}; V_{CC}=0\text{V}$	-	-	± 2	μA	
I_{CC}	Supply current	$V_I=5.5\text{V}$ or GND; $I_o=0\text{A}; V_{CC}=1.65\text{V to }5.5\text{V}$	-	-	4	μA	
ΔI_{CC}	Additional supply current	Per pin; $V_I=V_{CC}-0.6\text{V}; I_o=0\text{A}; V_{CC}=2.3\text{V to }5.5\text{V}$	-	-	500	μA	

7.4.3 AC Characteristics 1

T_{amb}=-40°C to +85°C, voltages are referenced to GND (ground=0V), unless otherwise specified.

SYMBOL	PARAMETER	CONDITIONS	MIN.	TYP. ⁽¹⁾	MAX.	UNIT	
t _{PHL}	nA, nB to nY propagation delay	See Figure 8-5	V _{CC} =1.65V to 1.95V	-	12.5	18.8	ns
			V _{CC} =2.3V to 2.7V	-	10.5	15.8	ns
			V _{CC} =2.7V	-	10	15	ns
			V _{CC} =3.0V to 3.6V	-	9.5	14.3	ns
			V _{CC} =4.5V to 5.5V	-	9	13.5	ns
t _{PLH}	nA, nB to nY propagation delay	See Figure 8-5	V _{CC} =1.65V to 1.95V	-	14	21	ns
			V _{CC} =2.3V to 2.7V	-	10	15	ns
			V _{CC} =2.7V	-	9.5	14.3	ns
			V _{CC} =3.0V to 3.6V	-	8.5	12.8	ns
			V _{CC} =4.5V to 5.5V	-	7.5	11.3	ns

(1) Typical values are measured at normal V_{CC} and T_{amb}=25°C.

7.4.4 AC Characteristics 2

T_{amb}=-40°C to +125°C, voltages are referenced to GND (ground=0V), unless otherwise specified.

SYMBOL	PARAMETER	CONDITIONS	MIN.	TYP.	MAX.	UNIT	
t _{PHL}	nA, nB to nY propagation delay	See Figure 8-5	V _{CC} =1.65V to 1.95V	-	-	20.8	ns
			V _{CC} =2.3V to 2.7V	-	-	17.8	ns
			V _{CC} =2.7V	-	-	17	ns
			V _{CC} =3.0V to 3.6V	-	-	16.3	ns
			V _{CC} =4.5V to 5.5V	-	-	15.5	ns
t _{PLH}	nA, nB to nY propagation delay	See Figure 8-5	V _{CC} =1.65V to 1.95V	-	-	23	ns
			V _{CC} =2.3V to 2.7V	-	-	17	ns
			V _{CC} =2.7V	-	-	16.3	ns
			V _{CC} =3.0V to 3.6V	-	-	14.8	ns
			V _{CC} =4.5V to 5.5V	-	-	13.3	ns

8 Detailed Description

8.1 Overview

The CJ74LVC2G08 provides a 2-input AND gate function. Inputs can be driven from either 3.3V or 5V devices. This feature allows the use of the CJ74LVC2G08 as a translator in a mixed 3.3V and 5V environment.

8.2 Functional Block Diagram

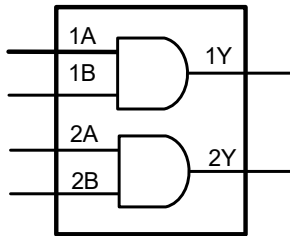

Figure 8-1 Logic symbol

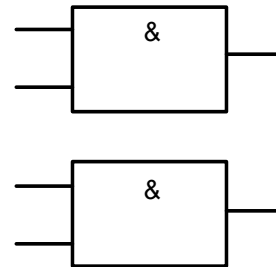

Figure 8-2 IEC logic symbol

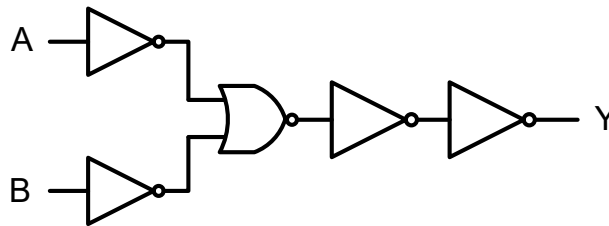

Figure 8-3 Logic diagram (one gate)

8.3 Function Table

INPUT		OUTPUT
nA	nB	nY
L	X	L
X	L	L
H	H	H

Note: H=HIGH voltage level; L=LOW voltage level; X=don't care.

8.4 Testing Circuit

8.4.1 AC Testing Circuit

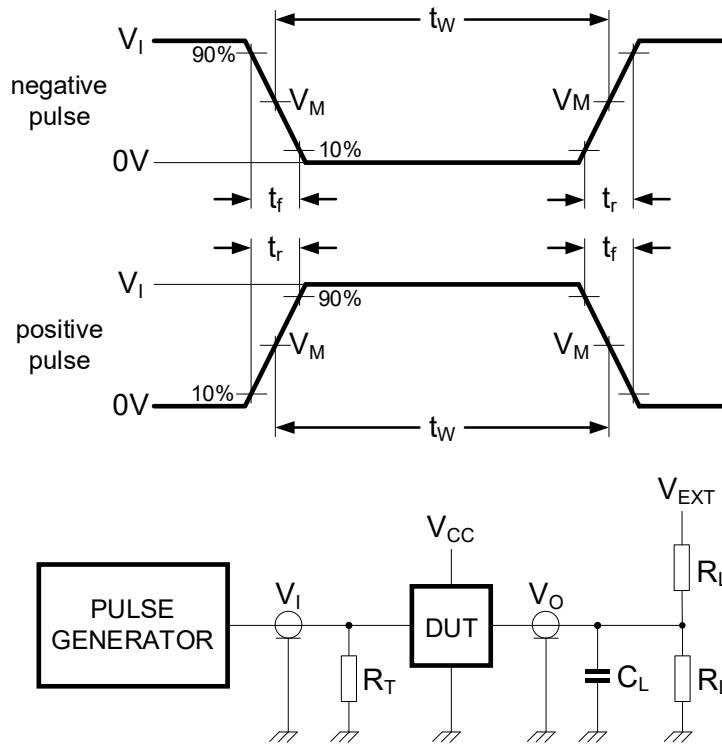

Figure 8-4 Test circuit for measuring switching times

Definitions for test circuit:

R_L =Load resistance.

C_L =Load capacitance including jig and probe capacitance.

R_T =Termination resistance; should be equal to the output impedance Z_o of the pulse generator.

V_{EXT} =External voltage for measuring switching times.

8.4.2 AC Testing Waveforms

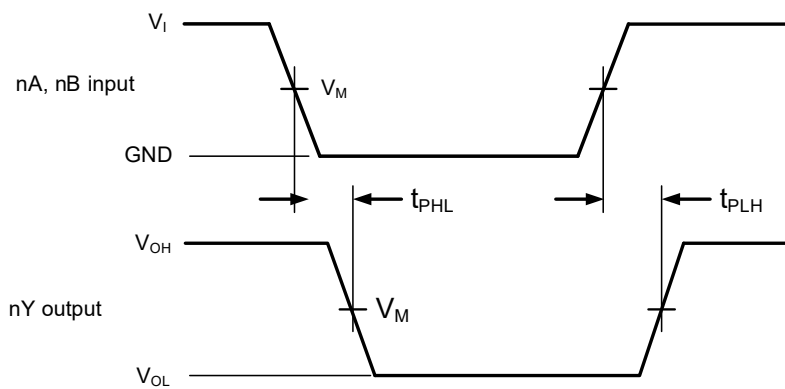

Figure 8-5 The input (nA, nB) to output (nY) propagation delays

8.4.3 Measurement Points

SUPPLY VOLTAGE	INPUT	OUTPUT
V_{CC}	V_M	V_M
1.65V to 1.95V	$0.5 \times V_{CC}$	$0.5 \times V_{CC}$
2.3V to 2.7V	$0.5 \times V_{CC}$	$0.5 \times V_{CC}$
2.7V	1.5V	1.5V
3.0V to 3.6V	1.5V	1.5V
4.5V to 5.5V	$0.5 \times V_{CC}$	$0.5 \times V_{CC}$

8.4.4 Test Data

SUPPLY VOLTAGE	INPUT		LOAD		V_{EXT}
V_{CC}	V_I	$t_r=t_f$	C_L	R_L	t_{PLH}, t_{PHL}
1.65V to 1.95V	V_{CC}	$\leq 3ns$	30pF	1k Ω	Open
2.3V to 2.7V	V_{CC}	$\leq 3ns$	30pF	500 Ω	Open
2.7V	2.7V	$\leq 3ns$	50pF	500 Ω	Open
3.0V to 3.6V	2.7V	$\leq 3ns$	50pF	500 Ω	Open
4.5V to 5.5V	V_{CC}	$\leq 3ns$	50pF	500 Ω	Open

9 Mechanical Information

9.1 TSSOP8 Mechanical Information

9.1.1 TSSOP8 Outline Dimensions

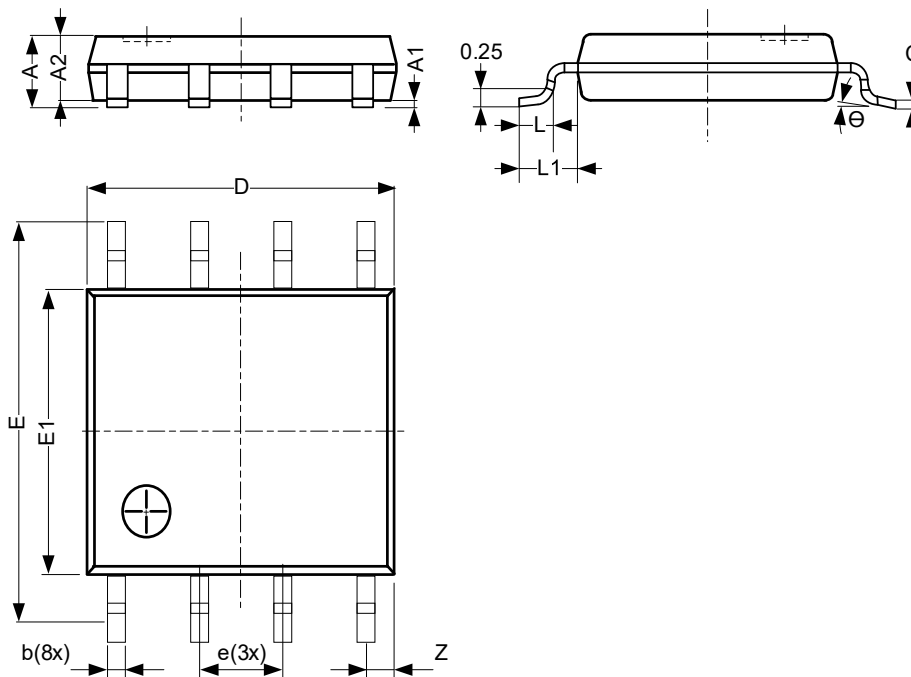

SYMBOL	Dimensions In Millimeters		
	Min.	Typ.	Max.
A	-	-	1.10
A1	0	-	0.15
A2	0.75	-	0.95
b	0.22	-	0.38
c	0.08	-	0.18
D	2.90	-	3.10
E	3.90	-	4.10
E1	2.90	-	3.10
e	0.65 BSC		
L	0.33	-	0.47
L1	-	0.50	-
Z	0.35	-	0.70
θ	0°	-	8°
Unit: mm			

9.2 VSSOP8 Mechanical Information

9.2.1 VSSOP8 Outline Dimensions

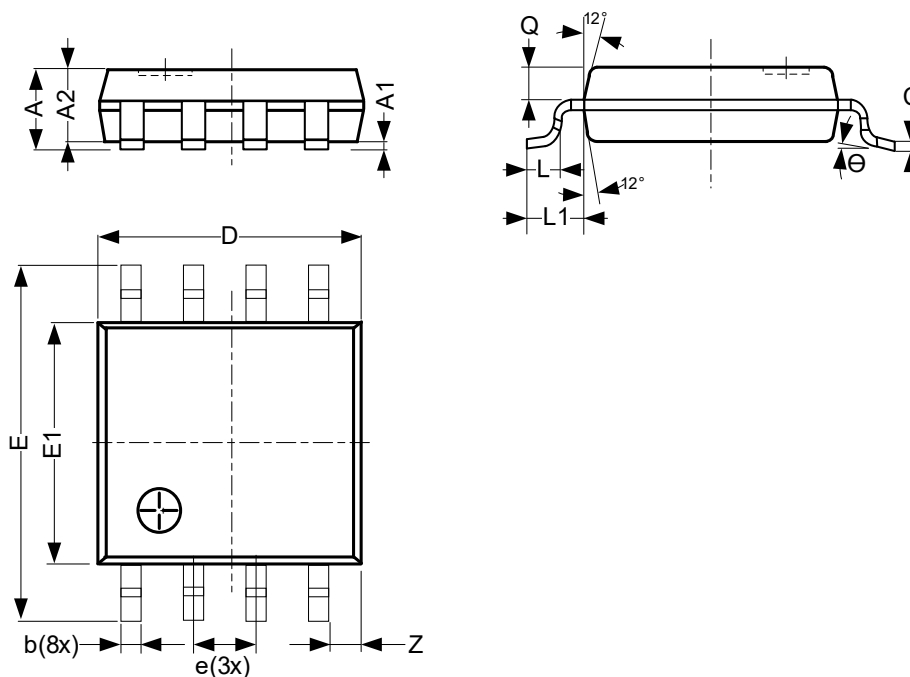

SYMBOL	Dimensions In Millimeters		
	Min.	Typ.	Max.
A	-	-	1.00
A1	0	-	0.15
A2	0.60	-	0.85
Q	0.19	-	0.21
b	0.17	-	0.27
c	0.08	-	0.23
D	1.90	-	2.10
E	3.00	-	3.20
E1	2.20	-	2.40
e	0.50 BSC		
L	0.15	-	0.40
L1	-	0.40	-
Z	0.10	-	0.40
Θ	0°	-	8°
Unit: mm			

10 Notes and Revision History

10.1 Associated Product Family and Others

To view other products of the same type or IC products of other types, click the official website of JSCJ -- <https://www.jscj-elec.com> for more details.

10.2 Notes

Electrostatic Discharge Caution



This IC may be damaged by ESD. Relevant personnel shall comply with correct installation and use specifications to avoid ESD damage to the IC. If appropriate measures are not taken to prevent ESD damage, the hazards caused by ESD include but are not limited to degradation of integrated circuit performance or complete damage of integrated circuit. For some precision integrated circuits, a very small parameter change may cause the whole device to be inconsistent with its published specifications.

DISCLAIMER

IMPORTANT NOTICE, PLEASE READ CAREFULLY

The information in this data sheet is intended to describe the operation and characteristics of our products. JSCJ has the right to make any modification, enhancement, improvement, correction or other changes to any content in this data sheet, including but not limited to specification parameters, circuit design and application information, without prior notice.

Any person who purchases or uses JSCJ products for design shall: 1. Select products suitable for circuit application and design; 2. Design, verify and test the rationality of circuit design; 3. Procedures to ensure that the design complies with relevant laws and regulations and the requirements of such laws and regulations. JSCJ makes no warranty or representation as to the accuracy or completeness of the information contained in this data sheet and assumes no responsibility for the application or use of any of the products described in this data sheet.

Without the written consent of JSCJ, this product shall not be used in occasions requiring high quality or high reliability, including but not limited to the following occasions: medical equipment, military facilities and aerospace. JSCJ shall not be responsible for casualties or property losses caused by abnormal use or application of this product.

Official Website: www.jscj-elec.com

Copyright © JIANGSU CHANGJING ELECTRONICS TECHNOLOGY CO., LTD