



CJ78M00E Series Three Terminal Positive Voltage Regulator

1 Introduction

The CJ78M00E series is a group of three terminal positive voltage linear regulators with multiple fixed output voltages. In the case of good heat dissipation, it can provide an output current of 500mA, and has internal short-circuit protection and thermal shutdown protection, which makes it not affected by overload. In addition to being used as fixed voltage regulators, these devices can also be used with external components to obtain adjustable output voltage and current, and can also be used as power transmission elements in precision regulators.

2 Available Packages

PART NUMBER	PACKAGE
CJ78M00E Series	TO-220-3L(A)
	TO-251-3L
	TO-251S
	TO-252-2L/TO-252-2L(B)

Note: For more detailed packaging information, see the part *Pin Configuration and Function* and the part *Mechanical Information*.

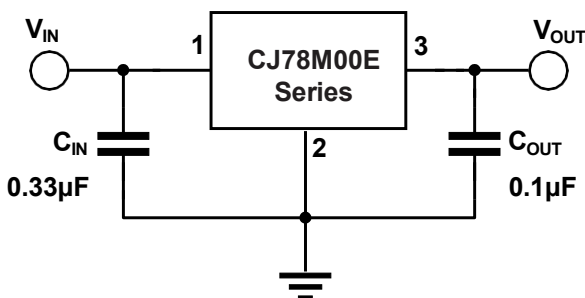

Figure 2-1. Fixed Output Voltage Regulator

3 Features

- Output Current:
up to 500mA at $T_J = 25^\circ\text{C}$
- Available Output Fixed Voltage: 5.0V,
- Output Voltage Tolerance at $T_J = 25^\circ\text{C}$:
 $\pm 2\%$ for Conventional Device
 $\pm 1\%$ can be Customized
 $\pm 5\%$ over the Operating T_J
- Dropout Voltage: 2.0V@350mA
- Power Supply Rejection Ratio:
70dB@120Hz (Typ.)
- Operating Junction Temperature:
-40 ~ 125°C
- Built-in Current Limit
- Short Circuit Protection
- Thermal Shutdown Protection

4 Applications

- Appliances and White Goods
- Building Automation
- Computing & Servers
- Electronic Point-of-sale
- Motor Drives
- On-Card Regulation
- Portable Devices
- Telecommunications
- TVs and Set-top Boxes

5 Pin Configuration and Marking Information

5.1 Pin Configuration and Function

TO-220-3L(A)

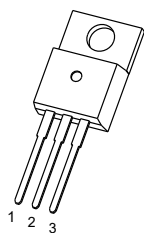

TO-251-3L

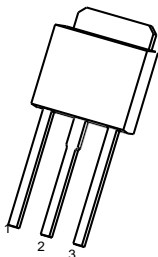

TO-251S

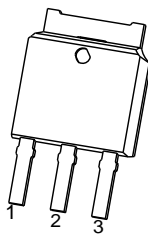

TO-252-2L

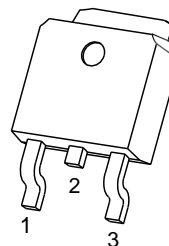

TO-252-2L(B)

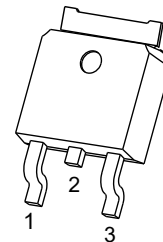

Figure 5-1. CJ78M00E Series Packages Top View

PIN		I/O	CJ78M00E Series Pin Function
NAME	NO.		DESCRIPTION
IN	1	I	Input voltage pin
GND	2	-	Ground pin
OUT	3	O	Output voltage pin

5.2 Marking Information

Figure 5-2. CJ78M00E Series Marking Information

TO-220-3L(A)	TO-251-3L	TO-251S	TO-252-2L	TO-252-2L(B)

"78MXX": Device code, the "XX" in the "78MXXE" represents the output voltage, for example, if $V_{OUT} = 5.0V$, the "XX" is "05".

"YYYY": Code.

6 Specifications

6.1 Absolute Maximum Ratings⁽¹⁾

(over operating free-air temperature range, unless otherwise specified)

CHARACTERISTIC		SYMBOL	VALUE	UNIT
Maximum input voltage ⁽²⁾		V _{IN}	35	V
Maximum power dissipation	CJ78M00E Series	TO-220-3L(A)	Internally Limited ⁽³⁾	W
		TO-251-3L		
		TO-251S		
		TO-252-2L		
		TO-252-2L(B)		
Maximum junction temperature		T _{J Max}	150	°C
Storage temperature		T _{stg}	-65 ~ 150	°C
Soldering temperature & time		T _{solder}	260°C, 10s	-

(1) Stresses beyond those listed under *Absolute Maximum Ratings* may cause permanent damage to the device. These are stress ratings only, which do not imply functional operation of the device at these or any other conditions beyond those indicated under *Recommended Operating Conditions*. Exposure to absolute maximum rated conditions for extended periods may affect device reliability.

(2) All voltages are with respect to network ground terminal.

(3) Refer to *Thermal Information* for details.

6.2 Recommended Operating Conditions

PARAMETER	SYMBOL	MIN.	NOM.	MAX.	UNIT
Operating junction temperature	T _J	-40	-	125	°C
Operating ambient temperature	T _A	-	-(4)	-	°C

(4) It is necessary to ensure that the operating junction temperature of the equipment does not exceed the rated value of the recommended operating conditions when using the device for design.

6 Specifications

6.3 ESD Ratings

ESD RATINGS		SYMBOL	VALUE	UNIT
Electrostatic discharge ⁽⁵⁾	Human body model	$V_{ESD-HBM}$	6000	V

(5) ESD testing is conducted in accordance with the relevant specifications formulated by the Joint Electronic Equipment Engineering Commission (JEDEC). The human body mode (HBM) electrostatic discharge test is based on the JESD22-114D test standard, using a 100pF capacitor and discharging to each pin of the device through a resistance of 1.5kΩ. The electrostatic discharge test in mechanical mode (MM) is based on the JESD22-115-A test standard and uses a 200pF capacitor to discharge directly to each pin of the device.

6.4 Thermal Information

THERMAL METRIC ⁽⁶⁾	SYMBOL	CJ78M00E Series		UNIT
Junction-to-ambient thermal resistance	$R_{\theta JA}$	TO-220-3L(A)	TO-251-3L	°C/W
		66.7	80.0	
		TO-251S	TO-252-2L	
		80.0	80.0	
		TO-252-2L(B)		
Reference maximum power dissipation for continuous operation	$P_{D Ref}$	TO-220-3L	TO-251-3L	W
		1.50	1.25	
		TO-251S	TO-252-2L	
		1.25	1.25	
		TO-252-2L(B)		
		1.25		

(6) $T_A = 25^\circ\text{C}$, the thermal resistance test of TO-220-3L packages did not add additional radiators, see the part *Notes* for more information about thermal metrics.

6 Specifications

6.5 Electrical Characteristics

CJ78M05E ($V_{IN} = 10V$, $I_{OUT} = 350mA$, $C_{IN} = 0.33\mu F$, $C_{OUT} = 0.1\mu F$, $T_J = 25^\circ C$, unless otherwise specified)

CHARACTERISTIC	SYMBOL	TEST CONDITIONS ⁽⁷⁾	MIN.	TYP. ⁽⁸⁾	MAX.	UNIT	
Output voltage ⁽⁹⁾	V_{OUT}	$T_J = 25^\circ C$	$\pm 2\%$ grade ⁽¹⁰⁾	4.90	5.00	5.10	V
			$\pm 1\%$ grade ⁽¹⁰⁾	4.95		5.05	
		$V_{IN} = 7$ to $20V$, $I_{OUT} = 5$ to $350mA$	4.75	5.00	5.25		
Line regulation	LNR	$V_{IN} = 7$ to $25V$, $I_{OUT} = 200mA$	-	6.0	100	mV	
		$V_{IN} = 8$ to $25V$, $I_{OUT} = 200mA$	-	2.0	50		
Load regulation	LDR	$I_{OUT} = 5$ to $500mA$	-	15	100	mV	
		$I_{OUT} = 5$ to $200mA$	-	5.0	50		
Quiescent current	I_Q	-	-	3.3	6.0	mA	
Quiescent current change	ΔI_Q	$V_{IN} = 8$ to $25V$, $I_{OUT} = 200mA$	-	-	0.8	mA	
		$I_{OUT} = 5$ to $350mA$	-	-	0.5		
Output noise voltage	V_N	$f = 10$ to $100kHz$	-	40	-	μV	
Ripple rejection	RR	$V_{IN} = 8$ to $18V$, $I_{OUT} = 300mA$, $f = 120Hz$	-	70	-	dB	
Dropout voltage ⁽¹¹⁾	V_D	$I_{OUT} = 350mA$	-	2.0	-	V	
Short circuit current	I_{SC}	$V_{IN} = 10V$, OUT short to GND	-	400	-	mA	
Peak current	I_{Peak}	-	-	0.9	-	A	

Note:

(7)Pulse test technology is used to make T_J as close to T_A as possible. Thermal effects must be considered separately.

(8)Typical numbers are at $25^\circ C$ (T_J) and represent the most likely norm.

(9)This specification only applies to the DC power consumption allowed by the absolute maximum rating.

(10) $\pm 2\%$ for conventional device, $\pm 1\%$ can be customized.

(11)The difference of output voltage and input voltage when input voltage is decreased gradually till output voltage equals to 95% of V_{OUT} .

6 Specifications

6.5 Electrical Characteristics

CJ78M06E ($V_{IN} = 11V$, $I_{OUT} = 350mA$, $C_{IN} = 0.33\mu F$, $C_{OUT} = 0.1\mu F$, $T_J = 25^\circ C$, unless otherwise specified)

CHARACTERISTIC	SYMBOL	TEST CONDITIONS ⁽⁷⁾	MIN.	TYP. ⁽⁸⁾	MAX.	UNIT	
Output voltage ⁽⁹⁾	V_{OUT}	$T_J = 25^\circ C$	$\pm 2\%$ grade ⁽¹⁰⁾	5.88	6.00	6.12	V
			$\pm 1\%$ grade ⁽¹⁰⁾	5.94		6.06	
		$V_{IN} = 8$ to $21V$, $I_{OUT} = 5$ to $350mA$	5.70	6.00	6.30		
Line regulation	LNR	$V_{IN} = 8$ to $25V$, $I_{OUT} = 200mA$	-	6.0	100	mV	
		$V_{IN} = 9$ to $25V$, $I_{OUT} = 200mA$	-	2.0	50		
Load regulation	LDR	$I_{OUT} = 5$ to $500mA$	-	18	120	mV	
		$I_{OUT} = 5$ to $200mA$	-	8.0	60		
Quiescent current	I_Q	-	-	3.3	6.0	mA	
Quiescent current change	ΔI_Q	$V_{IN} = 9$ to $25V$, $I_{OUT} = 200mA$	-	-	0.8	mA	
		$I_{OUT} = 5$ to $350mA$	-	-	0.5		
Output noise voltage	V_N	$f = 10$ to $100kHz$	-	45	-	μV	
Ripple rejection	RR	$V_{IN} = 9$ to $19V$, $I_{OUT} = 300mA$, $f = 120Hz$	-	70	-	dB	
Dropout voltage ⁽¹¹⁾	V_D	$I_{OUT} = 350mA$	-	2.0	-	V	
Short circuit current	I_{SC}	$V_{IN} = 11V$, OUT short to GND	-	380	-	mA	
Peak current	I_{Peak}	-	-	0.9	-	A	

Note:

(7)Pulse test technology is used to make T_J as close to T_A as possible. Thermal effects must be considered separately.

(8)Typical numbers are at $25^\circ C$ (T_J) and represent the most likely norm.

(9)This specification only applies to the DC power consumption allowed by the absolute maximum rating.

(10) $\pm 2\%$ for conventional device, $\pm 1\%$ can be customized.

(11)The difference of output voltage and input voltage when input voltage is decreased gradually till output voltage equals to 95% of V_{OUT} .

6 Specifications

6.5 Electrical Characteristics

CJ78M08E ($V_{IN} = 14V$, $I_{OUT} = 350mA$, $C_{IN} = 0.33\mu F$, $C_{OUT} = 0.1\mu F$, $T_J = 25^\circ C$, unless otherwise specified)

CHARACTERISTIC	SYMBOL	TEST CONDITIONS ⁽⁷⁾	MIN.	TYP. ⁽⁸⁾	MAX.	UNIT	
Output voltage ⁽⁹⁾	V_{OUT}	$T_J = 25^\circ C$	$\pm 2\%$ grade ⁽¹⁰⁾	7.84	8.00	8.16	V
			$\pm 1\%$ grade ⁽¹⁰⁾	7.92		8.08	
		$V_{IN} = 10.5$ to $23V$, $I_{OUT} = 5$ to $350mA$	7.60	8.00	8.40		
Line regulation	LNR	$V_{IN} = 10.5$ to $25V$, $I_{OUT} = 200mA$	-	6.0	100	mV	
		$V_{IN} = 11$ to $25V$, $I_{OUT} = 200mA$	-	2.0	50		
Load regulation	LDR	$I_{OUT} = 5$ to $500mA$	-	20	160	mV	
		$I_{OUT} = 5$ to $200mA$	-	10	80		
Quiescent current	I_Q	-	-	3.3	6.0	mA	
Quiescent current change	ΔI_Q	$V_{IN} = 10.5$ to $25V$, $I_{OUT} = 200mA$	-	-	0.8	mA	
		$I_{OUT} = 5$ to $350mA$	-	-	0.5		
Output noise voltage	V_N	$f = 10$ to $100kHz$	-	52	-	μV	
Ripple rejection	RR	$V_{IN} = 11.5$ to $21.5V$, $I_{OUT} = 300mA$, $f = 120Hz$	-	70	-	dB	
Dropout voltage ⁽¹¹⁾	V_D	$I_{OUT} = 350mA$	-	2.0	-	V	
Short circuit current	I_{SC}	$V_{IN} = 14V$, OUT short to GND	-	380	-	mA	
Peak current	I_{Peak}	-	-	0.9	-	A	

Note:

(7) Pulse test technology is used to make T_J as close to T_A as possible. Thermal effects must be considered separately.

(8) Typical numbers are at $25^\circ C$ (T_J) and represent the most likely norm.

(9) This specification only applies to the DC power consumption allowed by the absolute maximum rating.

(10) $\pm 2\%$ for conventional device, $\pm 1\%$ can be customized.

(11) The difference of output voltage and input voltage when input voltage is decreased gradually till output voltage equals to 95% of V_{OUT} .

6 Specifications

6.5 Electrical Characteristics

CJ78M09E ($V_{IN} = 15V$, $I_{OUT} = 350mA$, $C_{IN} = 0.33\mu F$, $C_{OUT} = 0.1\mu F$, $T_J = 25^\circ C$, unless otherwise specified)

CHARACTERISTIC	SYMBOL	TEST CONDITIONS ⁽⁷⁾	MIN.	TYP. ⁽⁸⁾	MAX.	UNIT	
Output voltage ⁽⁹⁾	V_{OUT}	$T_J = 25^\circ C$	$\pm 2\%$ grade ⁽¹⁰⁾	8.82	9.00	9.18	V
			$\pm 1\%$ grade ⁽¹⁰⁾	8.91		9.09	
		$V_{IN} = 11.5$ to $22V$, $I_{OUT} = 5$ to $350mA$	8.55	9.00	9.45		
Line regulation	LNR	$V_{IN} = 11.5$ to $25V$, $I_{OUT} = 200mA$	-	8.0	100	mV	
		$V_{IN} = 12$ to $25V$, $I_{OUT} = 200mA$	-	3.0	50		
Load regulation	LDR	$I_{OUT} = 5$ to $500mA$	-	20	180	mV	
		$I_{OUT} = 5$ to $200mA$	-	10	90		
Quiescent current	I_Q	-	-	3.3	6.0	mA	
Quiescent current change	ΔI_Q	$V_{IN} = 11.5$ to $25V$, $I_{OUT} = 200mA$	-	-	0.8	mA	
		$I_{OUT} = 5$ to $350mA$	-	-	0.5		
Output noise voltage	V_N	$f = 10$ to $100kHz$	-	52	-	μV	
Ripple rejection	RR	$V_{IN} = 12.5$ to $23V$, $I_{OUT} = 300mA$, $f = 120Hz$	-	68	-	dB	
Dropout voltage ⁽¹¹⁾	V_D	$I_{OUT} = 350mA$	-	2.0	-	V	
Short circuit current	I_{SC}	$V_{IN} = 15V$, OUT short to GND	-	360	-	mA	
Peak current	I_{Peak}	-	-	0.9	-	A	

Note:

(7) Pulse test technology is used to make T_J as close to T_A as possible. Thermal effects must be considered separately.

(8) Typical numbers are at $25^\circ C$ (T_J) and represent the most likely norm.

(9) This specification only applies to the DC power consumption allowed by the absolute maximum rating.

(10) $\pm 2\%$ for conventional device, $\pm 1\%$ can be customized.

(11) The difference of output voltage and input voltage when input voltage is decreased gradually till output voltage equals to 95% of V_{OUT} .

6 Specifications

6.5 Electrical Characteristics

CJ78M10E ($V_{IN} = 16V$, $I_{OUT} = 350mA$, $C_{IN} = 0.33\mu F$, $C_{OUT} = 0.1\mu F$, $T_J = 25^\circ C$, unless otherwise specified)

CHARACTERISTIC	SYMBOL	TEST CONDITIONS ⁽⁷⁾	MIN.	TYP. ⁽⁸⁾	MAX.	UNIT
Output voltage ⁽⁹⁾	V_{OUT}	$T_J = 25^\circ C$	$\pm 2\%$ grade ⁽¹⁰⁾	9.80	10.00	10.20
			$\pm 1\%$ grade ⁽¹⁰⁾	9.90		10.10
		$V_{IN} = 13$ to $30V$, $I_{OUT} = 5$ to $350mA$	9.50	10.00	10.50	V
Line regulation	LNR	$V_{IN} = 12.5$ to $30V$, $I_{OUT} = 200mA$	-	9.0	100	mV
		$V_{IN} = 13$ to $30V$, $I_{OUT} = 200mA$	-	3.0	50	
Load regulation	LDR	$I_{OUT} = 5$ to $500mA$	-	22	200	mV
		$I_{OUT} = 5$ to $200mA$	-	10	100	
Quiescent current	I_Q	-	-	3.3	6.0	mA
Quiescent current change	ΔI_Q	$V_{IN} = 12.5$ to $30V$, $I_{OUT} = 200mA$	-	-	0.8	mA
		$I_{OUT} = 5$ to $350mA$	-	-	0.5	
Output noise voltage	V_N	$f = 10$ to $100kHz$	-	64	-	μV
Ripple rejection	RR	$V_{IN} = 13.5$ to $24V$, $I_{OUT} = 300mA$, $f = 120Hz$	-	68	-	dB
Dropout voltage ⁽¹¹⁾	V_D	$I_{OUT} = 350mA$	-	2.0	-	V
Short circuit current	I_{SC}	$V_{IN} = 16V$, OUT short to GND	-	360	-	mA
Peak current	I_{Peak}	-	-	0.9	-	A

Note:

(7)Pulse test technology is used to make T_J as close to T_A as possible. Thermal effects must be considered separately.

(8)Typical numbers are at $25^\circ C$ (T_J) and represent the most likely norm.

(9)This specification only applies to the DC power consumption allowed by the absolute maximum rating.

(10) $\pm 2\%$ for conventional device, $\pm 1\%$ can be customized.

(11)The difference of output voltage and input voltage when input voltage is decreased gradually till output voltage equals to 95% of V_{OUT} .

6 Specifications

6.5 Electrical Characteristics

CJ78M12E ($V_{IN} = 19V$, $I_{OUT} = 350mA$, $C_{IN} = 0.33\mu F$, $C_{OUT} = 0.1\mu F$, $T_J = 25^\circ C$, unless otherwise specified)

CHARACTERISTIC	SYMBOL	TEST CONDITIONS ⁽⁷⁾	MIN.	TYP. ⁽⁸⁾	MAX.	UNIT	
Output voltage ⁽⁹⁾	V_{OUT}	$T_J = 25^\circ C$	$\pm 2\%$ grade ⁽¹⁰⁾	11.76	12.00	12.24	V
			$\pm 1\%$ grade ⁽¹⁰⁾	11.88		12.12	
		$V_{IN} = 14.5$ to $26V$, $I_{OUT} = 5$ to $350mA$	11.40	12.00	12.60		
Line regulation	LNR	$V_{IN} = 14.5$ to $30V$, $I_{OUT} = 200mA$	-	10	100	mV	
		$V_{IN} = 16$ to $30V$, $I_{OUT} = 200mA$	-	4.0	50		
Load regulation	LDR	$I_{OUT} = 5$ to $500mA$	-	25	240	mV	
		$I_{OUT} = 5$ to $200mA$	-	10	120		
Quiescent current	I_Q	-	-	3.3	6.0	mA	
Quiescent current change	ΔI_Q	$V_{IN} = 14.5$ to $30V$, $I_{OUT} = 200mA$	-	-	0.8	mA	
		$I_{OUT} = 5$ to $350mA$	-	-	0.5		
Output noise voltage	V_N	$f = 10$ to $100kHz$	-	75	-	μV	
Ripple rejection	RR	$V_{IN} = 15$ to $25V$, $I_{OUT} = 300mA$, $f = 120Hz$	-	66	-	dB	
Dropout voltage ⁽¹¹⁾	V_D	$I_{OUT} = 350mA$	-	2.0	-	V	
Short circuit current	I_{SC}	$V_{IN} = 19V$, OUT short to GND	-	320	-	mA	
Peak current	I_{Peak}	-	-	0.9	-	A	

Note:

(7)Pulse test technology is used to make T_J as close to T_A as possible. Thermal effects must be considered separately.

(8)Typical numbers are at $25^\circ C$ (T_J) and represent the most likely norm.

(9)This specification only applies to the DC power consumption allowed by the absolute maximum rating.

(10) $\pm 2\%$ for conventional device, $\pm 1\%$ can be customized.

(11)The difference of output voltage and input voltage when input voltage is decreased gradually till output voltage equals to 95% of V_{OUT} .

6 Specifications

6.5 Electrical Characteristics

CJ78M15E ($V_{IN} = 23V$, $I_{OUT} = 350mA$, $C_{IN} = 0.33\mu F$, $C_{OUT} = 0.1\mu F$, $T_J = 25^\circ C$, unless otherwise specified)

CHARACTERISTIC	SYMBOL	TEST CONDITIONS ⁽⁷⁾	MIN.	TYP. ⁽⁸⁾	MAX.	UNIT
Output voltage ⁽⁹⁾	V_{OUT}	$T_J = 25^\circ C$	$\pm 2\%$ grade ⁽¹⁰⁾	14.70	15.00	15.30
			$\pm 1\%$ grade ⁽¹⁰⁾	14.85		15.15
		$V_{IN} = 17.5$ to $27V$, $I_{OUT} = 5$ to $350mA$	14.25	15.00	15.75	V
Line regulation	LNR	$V_{IN} = 17.5$ to $30V$, $I_{OUT} = 200mA$	-	12	100	mV
		$V_{IN} = 20$ to $30V$, $I_{OUT} = 200mA$	-	5.0	50	
Load regulation	LDR	$I_{OUT} = 5$ to $500mA$	-	27	300	mV
		$I_{OUT} = 5$ to $200mA$	-	11	150	
Quiescent current	I_Q	-	-	3.3	6.0	mA
Quiescent current change	ΔI_Q	$V_{IN} = 17.5$ to $30V$, $I_{OUT} = 200mA$	-	-	0.8	mA
		$I_{OUT} = 5$ to $350mA$	-	-	0.5	
Output noise voltage	V_N	$f = 10$ to $100kHz$	-	90	-	μV
Ripple rejection	RR	$V_{IN} = 18.5$ to $28.5V$, $I_{OUT} = 300mA$, $f = 120Hz$	-	65	-	dB
Dropout voltage ⁽¹¹⁾	V_D	$I_{OUT} = 350mA$	-	2.0	-	V
Short circuit current	I_{SC}	$V_{IN} = 23V$, OUT short to GND	-	300	-	mA
Peak current	I_{Peak}	-	-	0.9	-	A

Note:

(7)Pulse test technology is used to make T_J as close to T_A as possible. Thermal effects must be considered separately.

(8)Typical numbers are at $25^\circ C$ (T_J) and represent the most likely norm.

(9)This specification only applies to the DC power consumption allowed by the absolute maximum rating.

(10) $\pm 2\%$ for conventional device, $\pm 1\%$ can be customized.

(11)The difference of output voltage and input voltage when input voltage is decreased gradually till output voltage equals to 95% of V_{OUT} .

6 Specifications

6.6 Typical Characteristics

CJ78M05E ($C_{IN} = 0.33\mu F$, $C_{OUT} = 0.1\mu F$, $T_J = 25^\circ C$, unless otherwise specified)

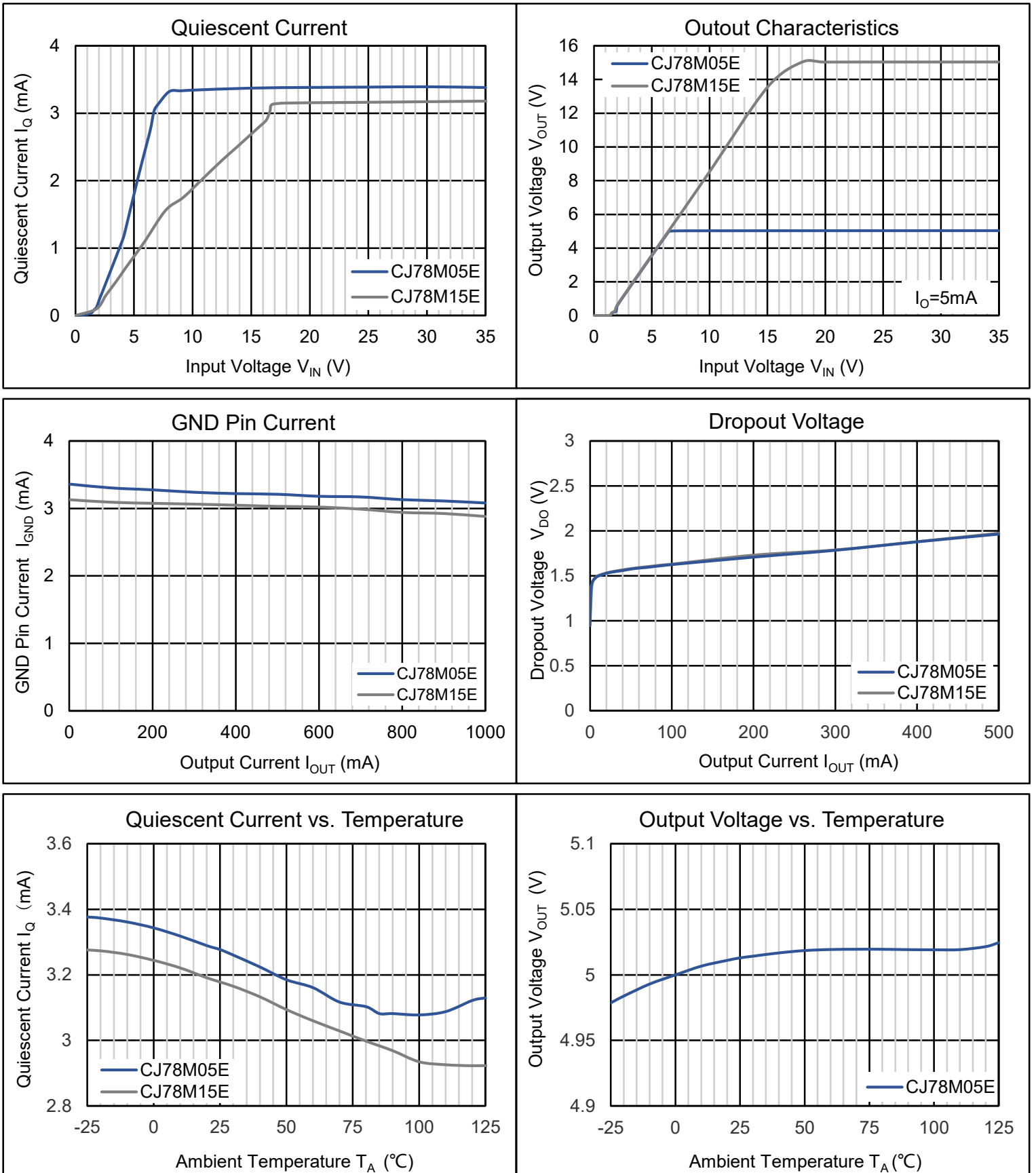

6 Specifications

6.6 Typical Characteristics (continued)

CJ78M05E ($C_{IN} = 0.33\mu F$, $C_{OUT} = 0.1\mu F$, $T_J = 25^\circ C$, unless otherwise specified)

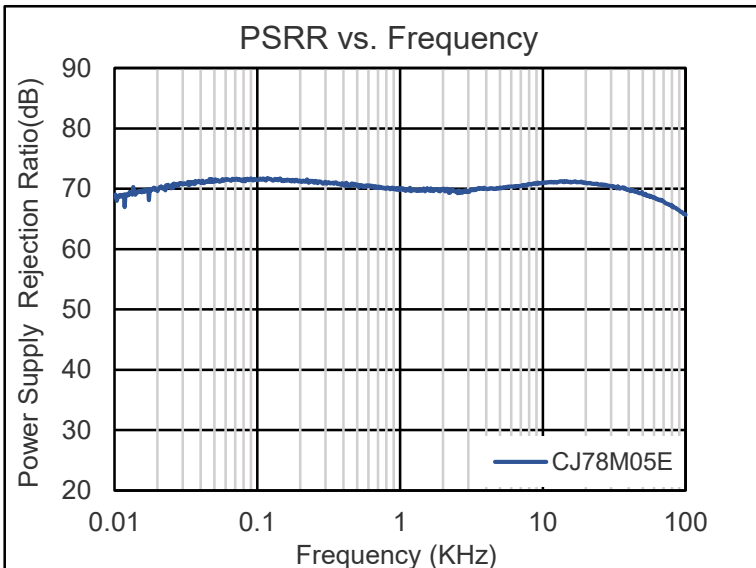
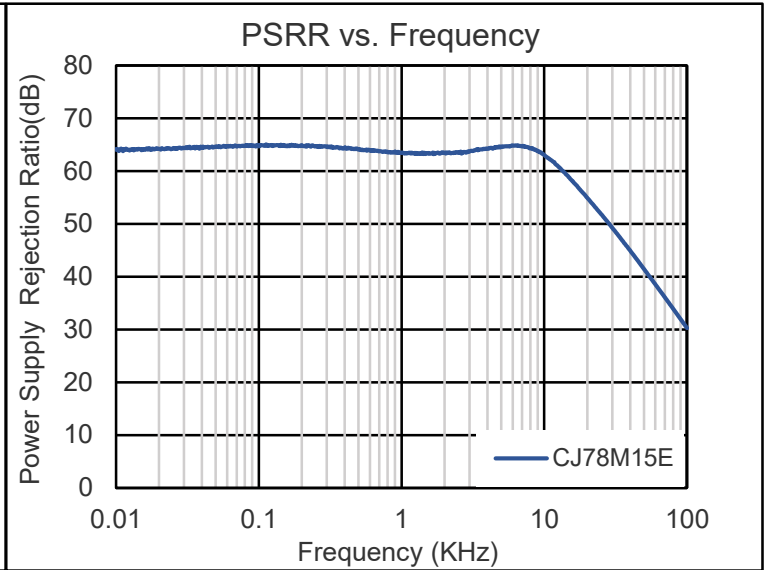
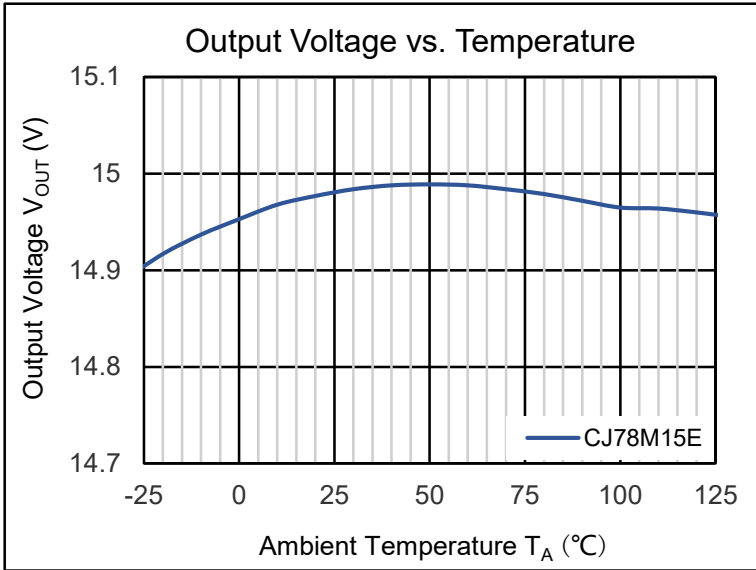

6 Specifications

6.6 Typical Characteristics (continued)

CJ78M05E ($C_{IN} = 0.33\mu\text{F}$, $C_{OUT} = 0.1\mu\text{F}$, $T_J = 25^\circ\text{C}$, unless otherwise specified)

Load Transient

CJ78M05E, $V_{IN} = 10\text{V}$, $I_{OUT} = 5 \sim 500\text{mA}$ (CH1: V_{OUT} , CH4: I_{OUT})

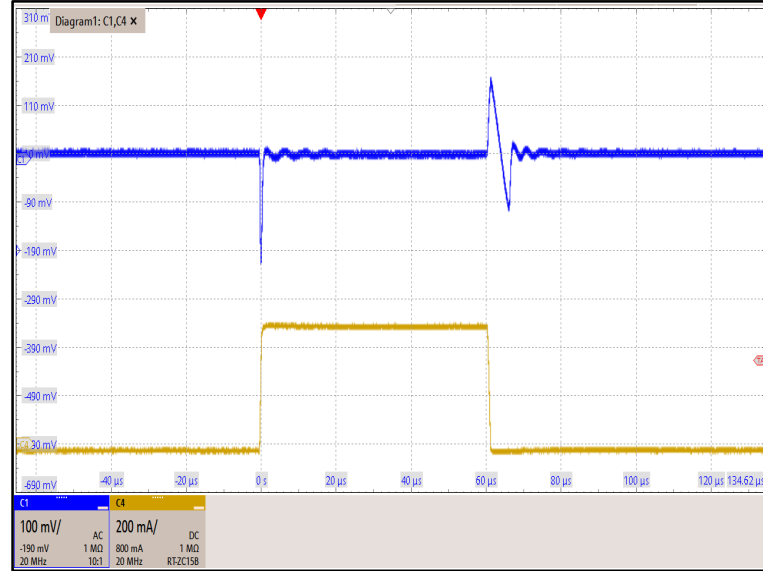

Power-up Response

CJ78M05E, $V_{IN} = 0 \sim 10\text{V}$ (CH1: V_{OUT} , CH2: V_{IN})

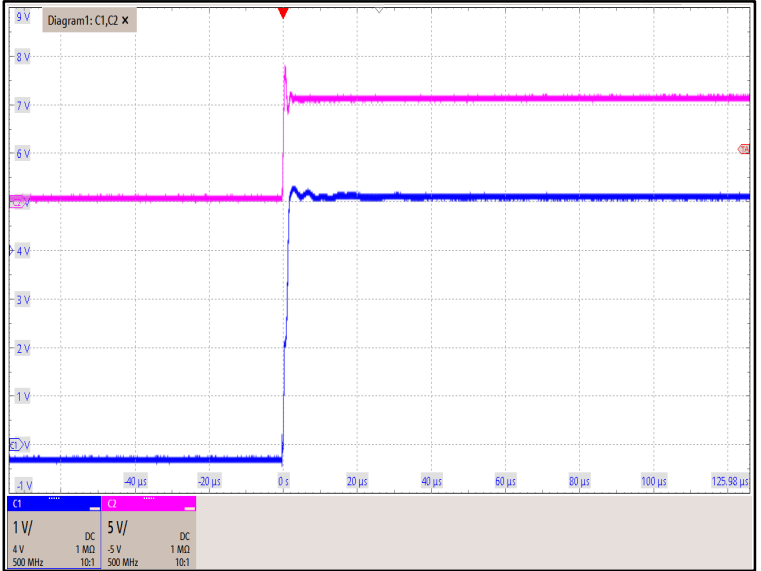

Load Transient

CJ78M15E, $V_{IN} = 20\text{V}$, $I_{OUT} = 5 \sim 500\text{mA}$ (CH2: V_{OUT} , CH4: I_{OUT})

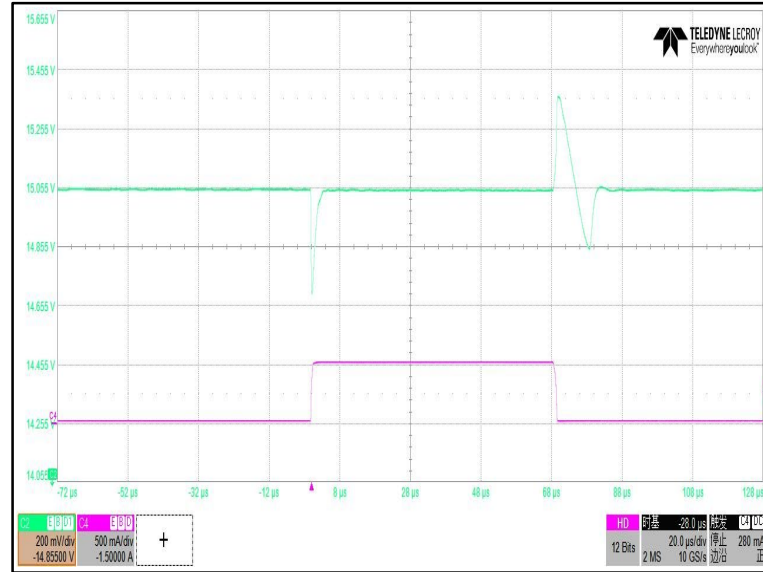

Power-up Response

CJ78M15E, $V_{IN} = 0 \sim 20\text{V}$ (CH1: V_{IN} , CH2: V_{OUT})

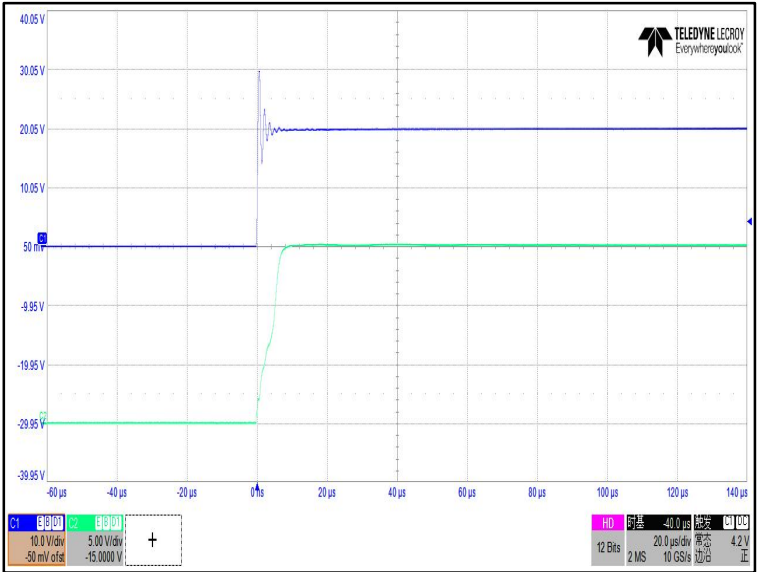

7 Detailed Description

7.1 Description

This series of fixed-voltage integrated-circuit voltage regulators is designed for a wide range of applications. The applications include on-card regulation for elimination of noise and distribution problems associated with single-point regulation. Each of these regulators can deliver up to 500mA of output current. The internal current-limiting and thermal-shutdown features of these regulators essentially make them immune to overload. In addition to use as fixed-voltage regulators, these devices can be used with external components to obtain adjustable output voltages and currents (not both) and also as the power-pass element in precision regulators.

7.2 Representative Schematic Diagram

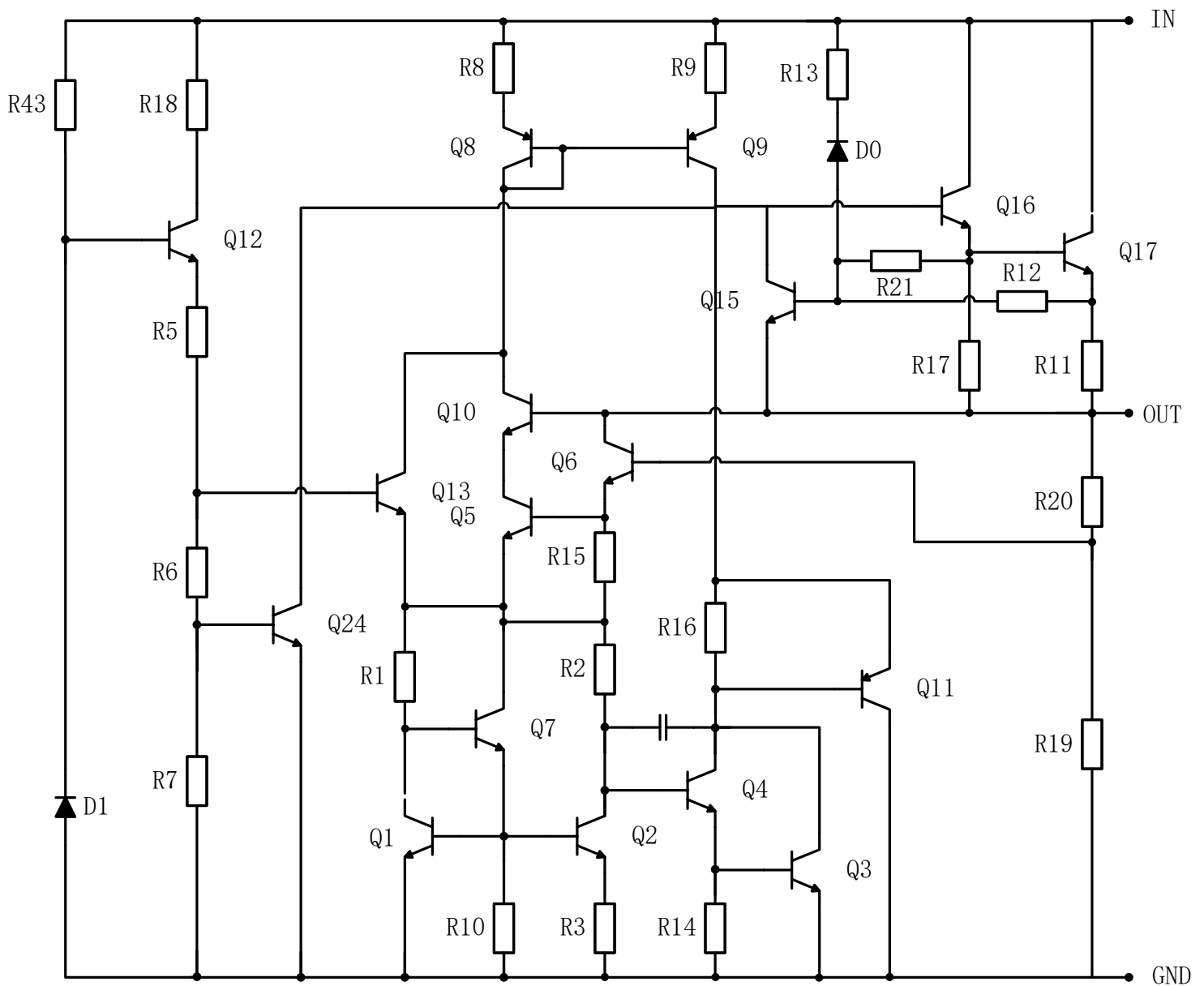

7 Detailed Description

7.3 Feature Description

Input Voltage

When the input voltage is lower than the rated range of the data sheet, the device will lose the regulation function of stabilizing the output voltage, that is, it is unable to maintain the output voltage within the rated range. When the input voltage is higher than the rated range of the data sheet, the device may cause irreversible damage or failure due to exceeding the maximum rated range of electrical stress.

Built-in Current Limit & Short Circuit Protection

The CJ78M00E series has built-in current limit and short circuit protection mechanism. When the output current of the device is too high, the output of the device will be shut down. When the output of the device is short circuited to ground, the output of the device will also be shut down and the output current will be maintained within a certain range.

Thermal Shutdown Protection

The CJ78M00E series has thermal shutdown protection mechanism. When the junction temperature exceeds the rated temperature range for normal operation in the data sheet, the device will enter the thermal shutdown state. At this time, the output voltage of the device will be reduced to prevent catastrophic damage to the chip due to accidental heat. When the junction temperature decreases and no longer remains too high, the device will release the thermal shutdown and output normally. To ensure reliable operation, please limit the junction temperature to the specified range of *Recommended Operating Conditions* in the data sheet. Applications that exceed the recommended temperature range may cause the equipment to exceed its operating specifications.

Although the internal protection circuitry of the device is designed to protect against thermal overall conditions, this circuitry is not intended to replace proper heat sinking. Continuously running the device into thermal shutdown or above the maximum recommended junction temperature reduces long-term reliability.

Output Current

Due to the internal integration of thermal shutdown protection, in the case of large output current, the device may enter the thermal shutdown state because the junction temperature is higher than the rated value in the data sheet. Therefore, the appropriate package should be selected for circuit design according to the heat dissipation power consumption of the package and the effective connection thermal resistance with the environment, so as to make the device emit more heat energy, so as to ensure the maximum load current capacity of the device. If the circuit design is appropriate and the device has good heat dissipation conditions, the CJ78M00E series can output a current of up to 500mA.

8 Application and Implementation

8.1 Risk Alert and Precautions

The CJ78M00E series is designed for thermal shutdown protection, built-in current limit and output short circuit protection. However, like any IC regulator, precautions are necessary to reduce the possibility of accidental damage to the regulator. The following describes the possible causes of unit damage or failure:

Electrostatic Discharge (ESD)

Electrostatic discharge (ESD) is a common near-field hazard source. It comes from many sources, such as human body, mechanical equipment and electronic components themselves. ESD can cause phenomena such as high voltage and instantaneous high current in a very short time, resulting in damage or failure of the device due to electric shock.

Instantaneous Electrical Surge

In some applications, a short duration but high energy spike may occur in the circuit, including peak voltage and surge current. They may cause unstable operation of the regulator, accelerated aging and potential hazards, and even damage or malfunction of the regulator. These peaks are usually more likely to occur in hot-plug, switch inductance, heavy-load, and other types of circuits.

Precautions for ESD and Electrical Surge

In the practical application of the circuit, adopting the following suggestions can reduce the possibility of device failure due to the above reasons to a certain extent.

1. Place a TVS between the IN and GND of the voltage regulator to absorb the peak voltage that may be generated due to ESD or other reasons. As shown in Figure 8-1;
2. Place a resistor with appropriate resistance in series before the IN of the voltage regulator, which can help the voltage regulator share part of the energy in case of surge. The resistance value of the resistance should not be too large. The specific resistance value depends on the application of the circuit. Generally, the resistance value of this resistance does not exceed 20Ω . As shown in Figure 8-2.

For the CJ78M00E series, it is recommended that the input voltage should not exceed 17V and the peak voltage should not exceed 35V. **When the input voltage is greater than 17V, or the peak voltage that may be greater than 35V may appear in the practical circuit, it is recommended to adopt the circuit layout shown in Figure 8-2 in the circuit design.**

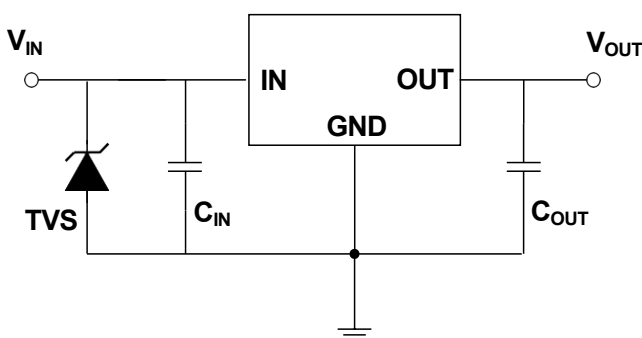

Figure 8-1. TVS is used at IN

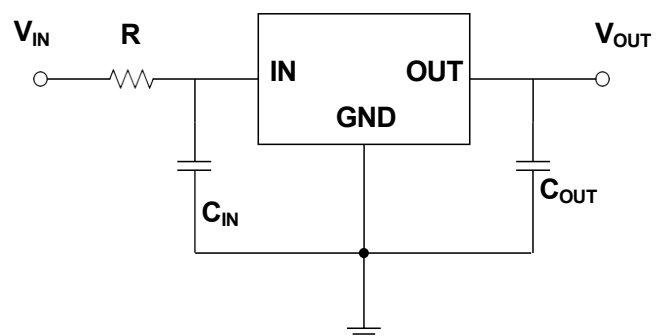

Figure 8-2. Resistance is used at IN

8 Application and Implementation

8.1 Risk Alert and Precautions (continued)

Large Output Capacitance

The CJ78M00E series can obtain better transient response with the help of output capacitance. However, if the output capacitor is relatively large, the surge current generated by the charging of the output capacitor will also be large at the moment of power on of the regulator, and the large surge current passing through the regulator may damage the internal circuit. When the output capacitance is large, adopting the circuit design shown in Figure 8-2 will reduce the possibility of damage to the device due to large surge current to a certain extent. It is recommended that the selection of output capacitor should not exceed 20 μ F. **If the selection of output capacitor exceeds 20 μ F, it is recommended to adopt the circuit design in Figure 8-2 to reduce the possibility of accidental failure of the device due to large surge current during power on.**

Junction-to-ambient Thermal Resistance $R_{\theta JA}$

Definition: The junction to ambient thermal resistance $R_{\theta JA}$ is a metric of the thermal performance of the device's packages. By comparing the metric of different companies on the same product package, the thermal performance of the product can be roughly estimated in a relative sense. $R_{\theta JA}$ is measured under the conditions specified in the corresponding specifications. If the measurement of $R_{\theta JA}$ of two products follows different specifications and standards, or although the same specifications and standards are adopted, it is not tested in strict accordance with the specifications, then the $R_{\theta JA}$ of two products will lose the meaning of comparison. This product follows the test specified by JEDEC in the EIA/JESD51-x series documents. $R_{\theta JA}$ is measured in still air with $T_A = 25^\circ\text{C}$ and installed on a 1 in 2 FR-4 board covered with 2 ounces of copper.

Usage: Junction to ambient thermal resistance $R_{\theta JA}$ is a parameter defined at the system level rather than on a single device or chip. In the test of $R_{\theta JA}$ provided in the data sheet, most of the heat generated by the operation of the device is dissipated through the test board rather than the packaging surface of the device. In fact, the design and layout of PCB (such as chip or pad size, internal package geometry, etc.) will significantly affect $R_{\theta JA}$. At this time, any calculation of the junction temperature or thermal power consumption of the device by applying $R_{\theta JA}$ in the data sheet will have a very large error, so that it does not match the real performance of the device.

Therefore, $R_{\theta JA}$ should be used as the relative comparison of product packaging thermal performance between different companies, rather than directly using $R_{\theta JA}$ in the data sheet in the actual calculation.

Reference Maximum Power Dissipation for Continuous Operation $P_{D \text{ Ref}}$

The reference maximum power dissipation for continuous operation $P_{D \text{ Ref}}$ is not an accurate value obtained from the actual test. It is a theoretical value obtained according to the heat dissipation capacity of packaging combined with practical application. It is used to compare the differences of heat dissipation capacity more intuitively between products of different companies. This value is only for estimation reference and cannot be used as an index of the actual performance of the device for circuit design.

8.2 Bypass Capacitance Selection

A capacitance between IN and GND (C_{IN}) is required if the regulator is located far from the power supply filter. It is recommended to use a 0.33 μ F capacitor for C_{IN} , and the capacitor (C_{IN}) should be placed as close to the device IN pin and GND pin as possible.

It is recommended to use a 0.1 μ F capacitor between OUT and GND (C_{OUT}), and the capacitor should be placed as close as possible between OUT and GND. The output capacitance can limit the high-frequency noise and help the device obtain the best stability and transient response.

The tolerance and temperature coefficient of the input and output capacitor (C_{IN} and C_{OUT}) must be considered to ensure that the capacitor can work normally within the rated working ambient temperature and rated working conditions of the equipment.

It is recommended that the output capacitor (C_{OUT}) should not exceed 20 μ F. When the output capacitor (C_{OUT}) exceeds 20 μ F, it is recommended to use the circuit layout shown in Figure 8-2. See *Large Output Capacitance* for more details.

8 Application and Implementation

8.3 System Example

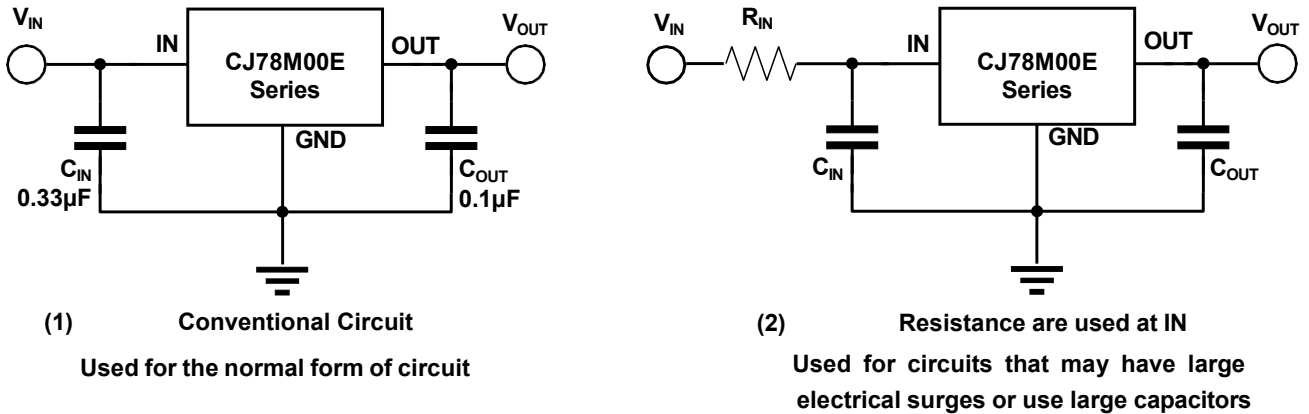

Figure 8-3. Fixed Output Regulator

8.4 Design Requirements and Procedure

The CJ78M00E series is mainly used to provide fixed output voltage regulation, the output voltage is selected based on the device variant, which is available in 5.0V, 6.0V, 8.0V, 9.0V and 12V regulator options, and it requires a very small number of equipment components. Some layout guidelines must be followed to ensure proper regulation of the output voltage with minimum noise:

- If the device is more than 4 inches from the power filter capacitor, it is recommended to use any type of input bypass capacitor 0.1µF or larger, and use the bypass capacitor to bypass the input terminal to ground. The optimum placement is closest to the input terminal of the device and the system GND;
- Take care to minimize the loop area formed by the bypass-capacitor connection, the input terminal, and the system GND;
- Traces carrying the load current must be wide to reduce the amount of parasitic trace inductance;
- In cases when V_{IN} shorts to ground, an external diode must be placed from OUT to IN to divert the surge current from the output capacitor and protect the IC. This diode must be placed close to the corresponding IC pins to increase their effectiveness.

NOTE

The application information in this section is not part of the data sheet component specification, and JSCJ makes no commitment or statement to guarantee its accuracy or completeness. Customers are responsible for determining the rationality of corresponding components in their circuit design and making tests and verifications to ensure the normal realization of their circuit design.

9 Notes and Revision History

9.1 Associated Product Family and Others

To view other products of the same type or IC products of other types, please click the official website of JSCJ -- <https://www.jscj-elec.com> for more details.

9.2 Notes

Electrostatic Discharge Caution



This IC may be damaged by ESD. Relevant personnel shall comply with correct installation and use specifications to avoid ESD damage to the IC. If appropriate measures are not taken to prevent ESD damage, the hazards caused by ESD include but are not limited to degradation of integrated circuit performance or complete damage of integrated circuit. For some precision integrated circuits, a very small parameter change may cause the whole device to be inconsistent with its published specifications.

9.3 Revision History

June, 2025: released CJ78M00E series rev - 1.0

10 Orderable, Mechanical, and Packaging Information

The following pages include mechanical packaging and orderable information. This information is the most current data available for the designated devices. This data is subject to change without notice and revision of this document. For browser based versions of this data sheet, refer to the left hand navigation.

Orderable Information

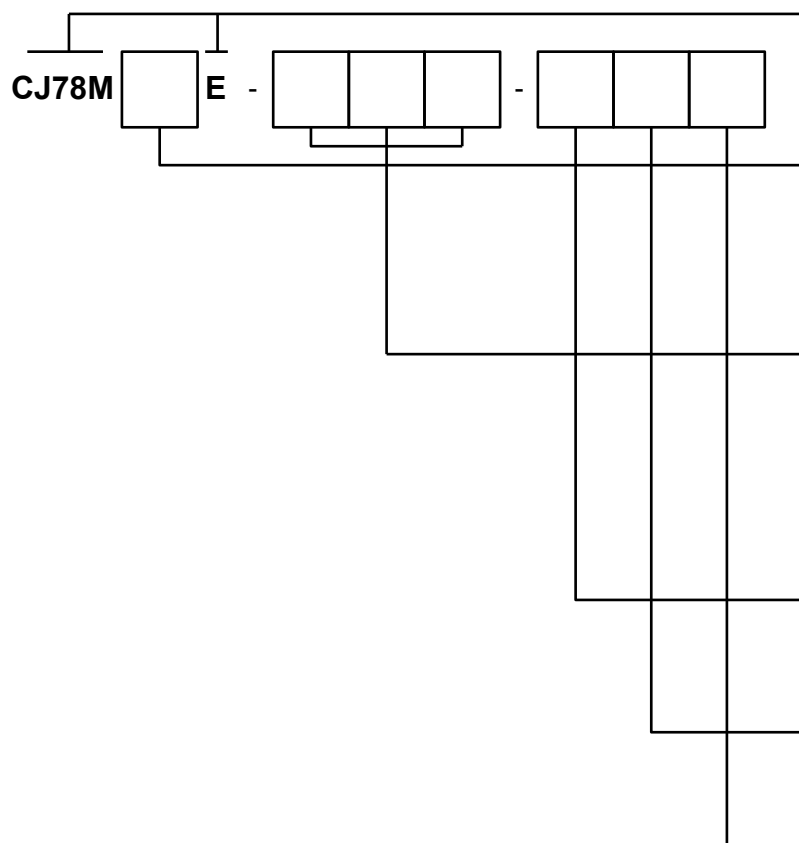

Device serial number.

Output voltage.

- 05: Fixed output 5.0V
- 06: Fixed output 6.0V
- 08: Fixed output 8.0V
- 09: Fixed output 9.0V
- 10: Fixed output 10 V
- 12: Fixed output 12 V
- 15: Fixed output 15 V

Package type.

- TBN: TO-220-3L(A)
- TDN: TO-251-3L
- TEN: TO-251S
- TFN: TO-252-2L/TO-252-2L(B)

Output voltage tolerances.

- A: ±2% grade
- B: ±1% grade

Outer package option.

- R: Tape and reel
- T: Tube

Eco-label.

- G: Green device, halogen free and lead free

Figure a. CJ78M00E Series Naming Conventions

MODEL	DEVICE	PACKAGE	OP T _J	ECO PLAN	MSL	PACKING OPTION	SORT
Conventional Device							
CJ78M-5.0	CJ78M05E-TBN-ATG	TO-220-3L(A)	-40 ~ 125°C	RoHS & Green	N / A for PkgType	Tube 50 Units / Rail	Active
CJ78M-6.0	CJ78M06E-TBN-ATG	TO-220-3L(A)	-40 ~ 125°C	RoHS & Green	N / A for PkgType	Tube 50 Units / Rail	Active
CJ78M-8.0	CJ78M08E-TBN-ATG	TO-220-3L(A)	-40 ~ 125°C	RoHS & Green	N / A for PkgType	Tube 50 Units / Rail	Active
CJ78M-9.0	CJ78M09E-TBN-ATG	TO-220-3L(A)	-40 ~ 125°C	RoHS & Green	N / A for PkgType	Tube 50 Units / Rail	Active
CJ78M-12	CJ78M12E-TBN-ATG	TO-220-3L(A)	-40 ~ 125°C	RoHS & Green	N / A for PkgType	Tube 50 Units / Rail	Active
CJ78M-15	CJ78M15E-TBN-ATG	TO-220-3L(A)	-40 ~ 125°C	RoHS & Green	N / A for PkgType	Tube 50 Units / Rail	Active
CJ78M-5.0	CJ78M05E-TFN-ARG	TO-252-2L/ TO-252-2L(B)	-40 ~ 125°C	RoHS & Green	Level 3 168 HR	Tape and Reel 2500 Units / Rail	Active

Orderable Information

MODEL	DEVICE	PACKAGE	OP T _J	ECO PLAN	MSL	PACKING OPTION	SORT
Conventional Device (continued)							
CJ78M-6.0	CJ78M06E-TFN-ARG	TO-252-2L/ TO-252-2L(B)	-40 ~ 125°C	RoHS & Green	Level 3 168 HR	Tape and Reel 2500 Units / Rail	Active
CJ78M-8.0	CJ78M08E-TFN-ARG	TO-252-2L/ TO-252-2L(B)	-40 ~ 125°C	RoHS & Green	Level 3 168 HR	Tape and Reel 2500 Units / Rail	Active
CJ78M-9.0	CJ78M09E-TFN-ARG	TO-252-2L/ TO-252-2L(B)	-40 ~ 125°C	RoHS & Green	Level 3 168 HR	Tape and Reel 2500 Units / Rail	Active
CJ78M-10	CJ78M10E-TFN-ARG	TO-252-2L/ TO-252-2L(B)	-40 ~ 125°C	RoHS & Green	Level 3 168 HR	Tape and Reel 2500 Units / Rail	Active
CJ78M-12	CJ78M12E-TFN-ARG	TO-252-2L/ TO-252-2L(B)	-40 ~ 125°C	RoHS & Green	Level 3 168 HR	Tape and Reel 2500 Units / Rail	Active
CJ78M-15	CJ78M15E-TFN-ARG	TO-252-2L/ TO-252-2L(B)	-40 ~ 125°C	RoHS & Green	Level 3 168 HR	Tape and Reel 2500 Units / Rail	Active
Customized Device							
CJ78M-x.x	CJ78MxxE-TDN-ATG	TO-251-3L	-40 ~ 125°C	RoHS & Green	Level 3 168 HR	Tube 80 Units / Rail	Customized
CJ78M-x.x	CJ78MxxE-TEN-ATG	TO-251S	-40 ~ 125°C	RoHS & Green	Level 3 168 HR	Tube 80 Units / Rail	Customized
CJ78M-x.x ±1% grade	CJ78MxxE-TBN-BTG	TO-220-3L(A)	-40 ~ 125°C	RoHS & Green	N / A for PkgType	Tube 50 Units / Rail	Customized
	CJ78MxxE-TFN-BRG	TO-252-2L/ TO-252-2L(B)	-40 ~ 125°C	RoHS & Green	Level 3 168 HR	Tape and Reel 2500 Units / Rail	Customized
	CJ78MxxE-TDN-BTG	TO-251-3L	-40 ~ 125°C	RoHS & Green	Level 3 168 HR	Tube 80 Units / Rail	Customized
	CJ78MxxE-TEN-BTG	TO-251S	-40 ~ 125°C	RoHS & Green	Level 3 168 HR	Tube 80 Units / Rail	Customized
Others	-	-	-	-	-	-	Customized

Note:

ECO PLAN: For the RoHS and Green certification standards of this product, please refer to the official report provided by JSCJ.

MSL: Moisture Sensitivity Level. Determined according to JEDEC industry standard classification.

SORT: Specifically defined as follows:

Active: Recommended for new products;

Customized: Products manufactured to meet the specific needs of customers;

Preview: The device has been released and has not been fully mass produced. The sample may or may not be available;

NoRD: It is not recommended to use the device for new design. The device is only produced for the needs of existing customers;

Obsolete: The device has been discontinued.

Mechanical Information

TO-220-3L(A) Mechanical Information

TO-220-3L(A) Outline Dimensions

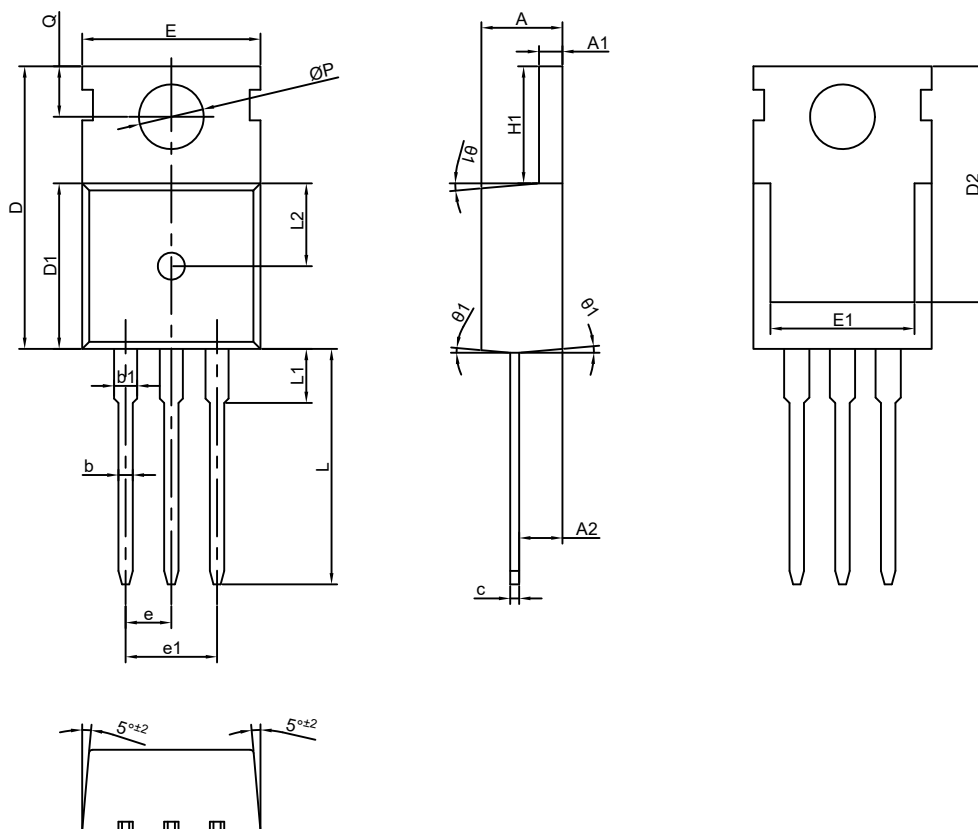

SYMBOL	DIMENSIONS IN MILLIMETERS			DIMENSIONS IN INCHES		
	MIN	NOM	MAX	MIN	NOM	MAX
A	4.400	4.500	4.600	0.173	0.177	0.181
A1	1.270	1.300	1.330	0.050	0.051	0.052
A2	2.300	2.400	2.500	0.091	0.094	0.098
b	0.700	-	0.900	0.028	-	0.035
b1	1.300	-	1.370	0.051	-	0.054
c	0.450	0.500	0.600	0.018	0.020	0.024
D	15.300	15.700	16.100	0.602	0.618	0.634
D1	9.100	9.200	9.300	0.358	0.362	0.366
D2	12.900	13.100	13.300	0.508	0.516	0.524
E	9.700	9.900	10.200	0.382	0.390	0.402
E1	7.700	7.900	8.100	0.303	0.311	0.319
e	2.450 Bsc.			0.096 Bsc.		
e1	5.08 Bsc.			0.200 Bsc.		
H1	6.300	6.500	6.700	0.248	0.256	0.264
L	12.780	13.080	13.380	0.503	0.515	0.527
L1	-	-	3.500	-	-	0.138
b2	4.06 Ref.			0.160 Bsc.		
ØP	3.550	3.600	3.650	0.140	0.142	0.144
Q	2.730	-	2.870	0.107	-	0.113
θ 1	3°	5°	7°	3°	5°	7°

Mechanical Information

TO-251-3L Mechanical Information

TO-251-3L Outline Dimensions

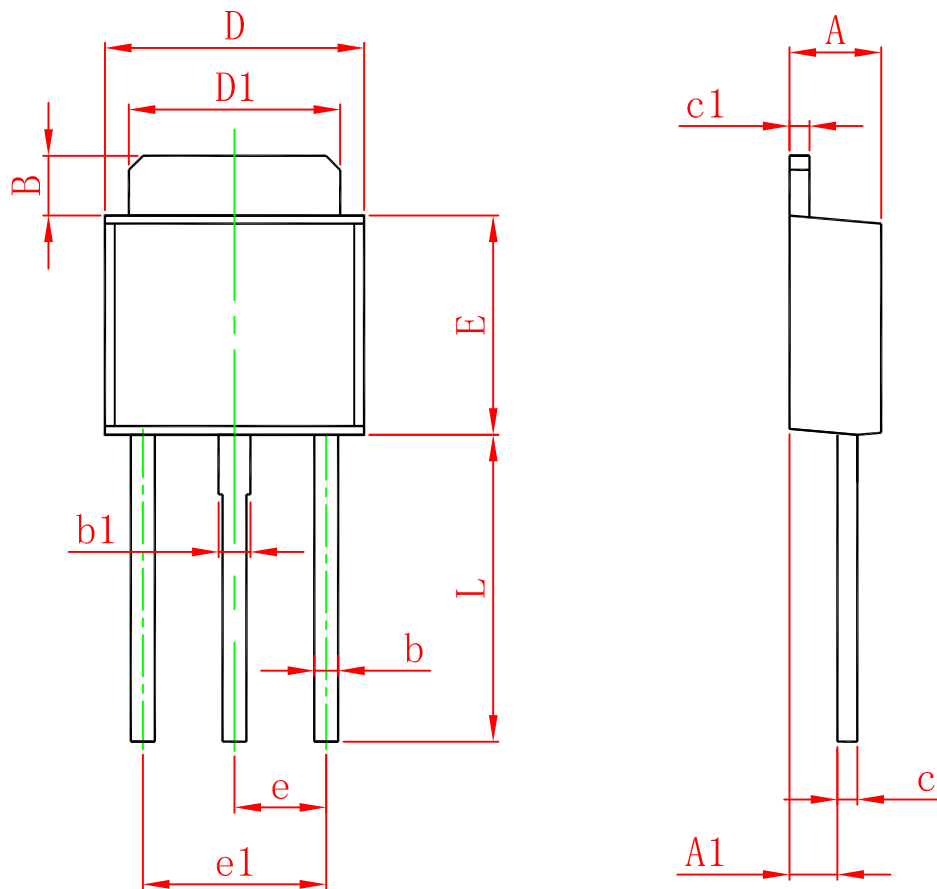

Symbol	Dimensions In Millimeters		Dimensions In Inches	
	Min.	Max.	Min.	Max.
A	2.200	2.400	0.087	0.094
A1	1.050	1.350	0.042	0.054
B	1.350	1.650	0.053	0.065
b	0.500	0.700	0.020	0.028
b1	0.700	0.900	0.028	0.035
c	0.430	0.580	0.017	0.023
c1	0.430	0.580	0.017	0.023
D	6.350	6.650	0.250	0.262
D1	5.200	5.400	0.205	0.213
E	5.400	5.700	0.213	0.224
e	2.300 TYP.		0.091 TYP.	
e1	4.500	4.700	0.177	0.185
L	7.500	7.900	0.295	0.311

Mechanical Information

TO-251S Mechanical Information

TO-251S Outline Dimensions

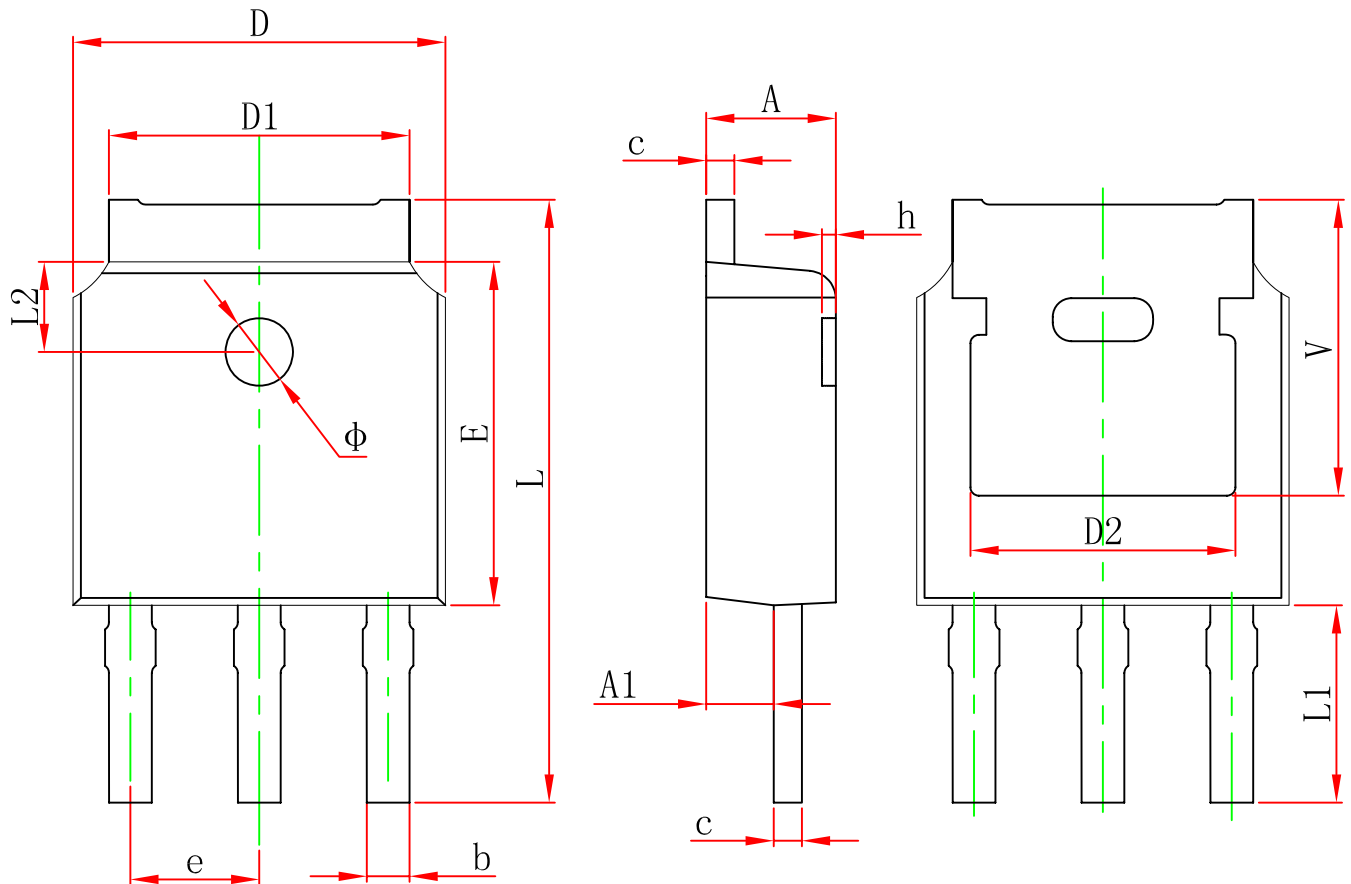

Symbol	Dimensions In Millimeters		Dimensions In Inches	
	Min.	Max.	Min.	Max.
A	2.200	2.400	0.087	0.094
A1	0.860	1.160	0.034	0.046
b	0.660	0.860	0.026	0.034
c	0.460	0.580	0.018	0.023
D	6.500	6.700	0.256	0.264
D1	5.100	5.460	0.201	0.215
D2	4.830 REF.		0.190 REF.	
E	6.000	6.200	0.236	0.244
e	2.186	2.386	0.086	0.094
L	10.400	11.000	0.409	0.433
L1	3.300	3.700	0.130	0.146
L2	1.600 REF.		0.063 REF.	
φ	1.100	1.300	0.043	0.051
h	0.000	0.300	0.000	0.012
V	5.350 REF.		0.211 REF.	

Mechanical Information

TO-252-2L Mechanical Information

TO-252-2L Outline Dimensions

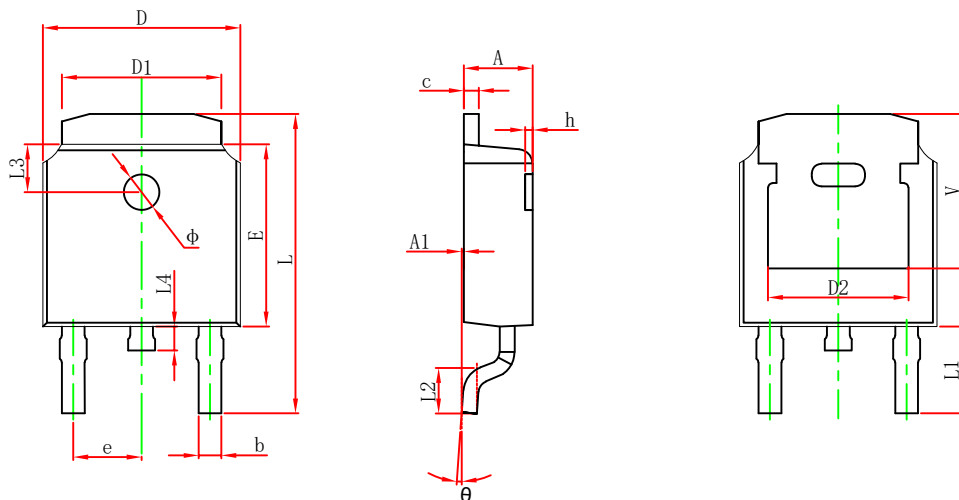

Symbol	Dimensions In Millimeters		Dimensions In Inches	
	Min.	Max.	Min.	Max.
A	2.200	2.400	0.087	0.094
A1	0.000	0.127	0.000	0.005
b	0.635	0.770	0.025	0.030
c	0.460	0.580	0.018	0.023
D	6.500	6.700	0.256	0.264
D1	5.100	5.460	0.201	0.215
D2	4.830 REF.		0.190 REF.	
E	6.000	6.200	0.236	0.244
e	2.186	2.386	0.086	0.094
L	9.712	10.312	0.382	0.406
L1	2.900 REF.		0.114 REF.	
L2	1.400	1.700	0.055	0.067
L3	1.600 REF.		0.063 REF.	
L4	0.600	1.000	0.024	0.039
phi	1.100	1.300	0.043	0.051
theta	0°	8°	0°	8°
h	0.000	0.300	0.000	0.012
V	5.250 REF.		0.207 REF.	

TO-252-2L Suggest Pad Layout

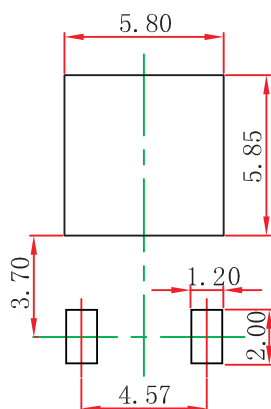

NOTE:

1. Controlling dimension: in millimeters.
2. General tolerance: $\pm 0.05\text{mm}$.
3. The pad layout is for reference purposes only.

Mechanical Information

TO-252-2L(B) Mechanical Information

TO-252-2L(B) Outline Dimensions

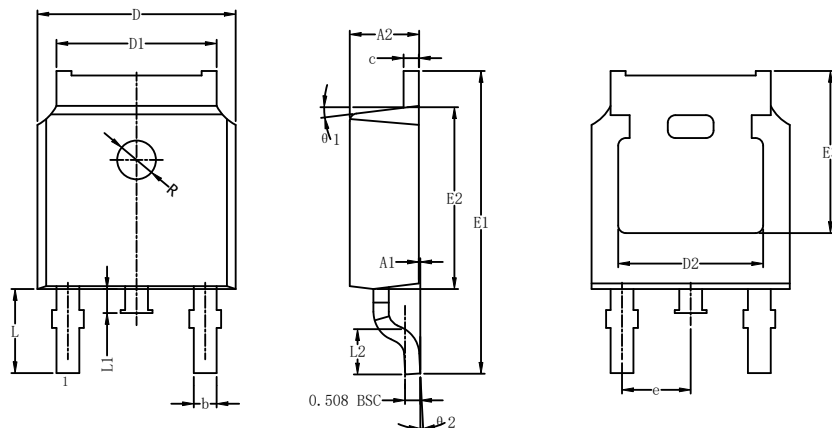

SYMBOL	DISMENSIONS IN MILLIMETERS			DISMENSIONS IN INCHES		
	MIN	NOM	MAX	MIN	NOM	MAX
A1	0.000	-	0.127	0.000	-	0.005
A2	2.200	2.300	2.400	0.087	0.091	0.094
b	0.660	0.760	0.860	0.026	0.030	0.034
c	0.508 REF.			0.508 REF.		
D	6.500	6.600	6.700	0.256	0.260	0.264
D1	5.100	5.320	5.460	0.201	0.209	0.215
D2	4.830 REF.			4.830 REF.		
e	2.286 BSC.			2.286 BSC.		
E1	9.700	9.900	10.100	0.382	0.390	0.398
E2	6.000	6.100	6.200	0.236	0.240	0.244
E3	5.200 REF.			5.200 REF.		
L	2.850 REF.			2.850 REF.		
L1	0.600	0.800	1.000	0.024	0.031	0.039
L2	1.400	1.500	1.700	0.055	0.059	0.067
R	1.300 REF.			1.300 REF.		
theta 1	7° REF.			7° REF.		
theta 2	0°	-	10°	0°	-	10°

TO-252-2L(B) Suggest Pad Layout

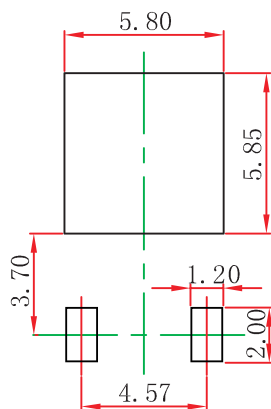

NOTE:

1. Controlling dimension: in millimeters.
2. General tolerance: $\pm 0.05\text{mm}$.
3. The pad layout is for reference purposes only.

Packaging Information

TO-252-2L/TO-252-2L(B) Tape and Reel Information

TO-252-2L/TO-252-2L(B) Embossed Carrier Tape

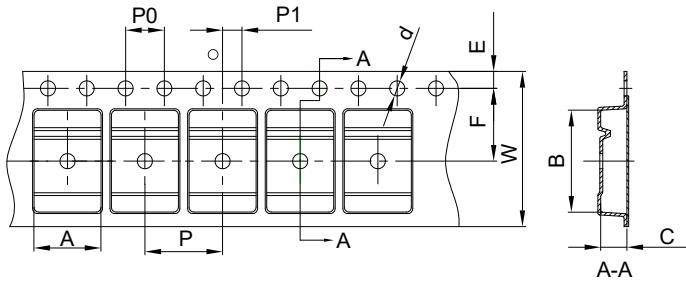

Packaging Description:

TO-252-2L parts are shipped in tape. The carrier tape is made from a dissipative (carbon filled) polycarbonate resin. The cover tape is a multilayer film (Hear Activated Adhesive in nature) primarily composed of polyester film, adhesive layer, sealant, and anti-static sprayed agent. These reeled parts in standard option are shipped with 2500 units per 13" or 33.0 cm diameter reel. The reels are clear in color and is made of polystyrene plastic (anti-static coated).

Dimensions are in millimeter										
Pkg type	A	B	C	d	E	F	P0	P	P1	W
TO-252	6.90	10.50	2.70	Φ1.55	1.75	7.50	4.00	8.00	2.00	16.00

TO-252-2L Tape Leader and Trailer

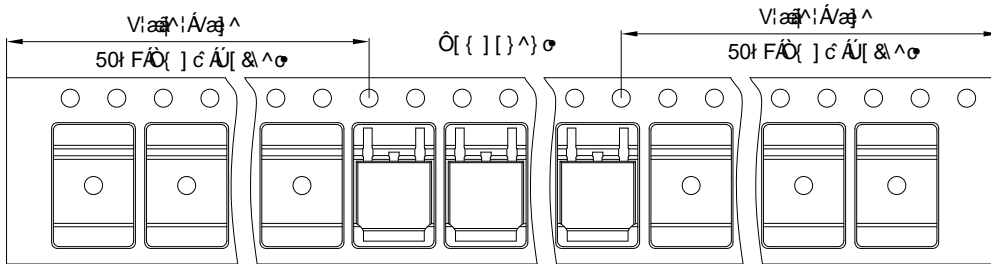

TO-252-2L Reel

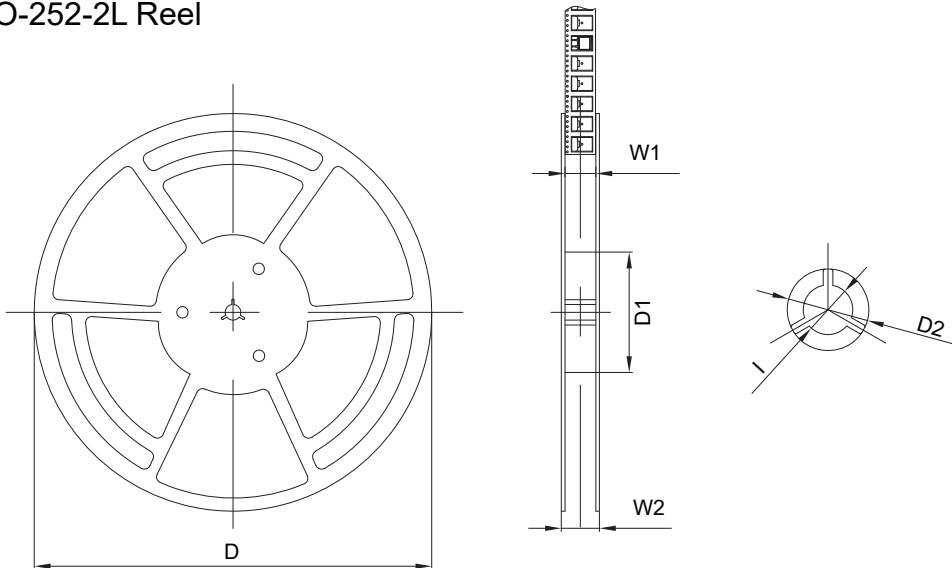

Dimensions are in millimeter						
Reel	D	D1	D2	W1	W2	l
13" Dia	330.00	100.00	Φ21.00	16.40	21.40	Φ13.00

Reel	Reel Size	Box	Box Size(mm)	Carton	Carton Size(mm)
2500 pcs	13 inch	5000 pcs	360×360×65	25000 pcs	378×358×382

DISCLAIMER

IMPORTANT NOTICE, PLEASE READ CAREFULLY

The information in this data sheet is intended to describe the operation and characteristics of our products. JSCJ has the right to make any modification, enhancement, improvement, correction or other changes to any content in this data sheet, including but not limited to specification parameters, circuit design and application information, without prior notice.

Any person who purchases or uses JSCJ products for design shall: 1. Select products suitable for circuit application and design; 2. Design, verify and test the rationality of circuit design; 3. Procedures to ensure that the design complies with relevant laws and regulations and the requirements of such laws and regulations. JSCJ makes no warranty or representation as to the accuracy or completeness of the information contained in this data sheet and assumes no responsibility for the application or use of any of the products described in this data sheet.

Without the written consent of JSCJ, this product shall not be used in occasions requiring high quality or high reliability, including but not limited to the following occasions: medical equipment, military facilities and aerospace. JSCJ shall not be responsible for casualties or property losses caused by abnormal use or application of this product.

Official Website: www.jscj-elec.com

Copyright © JIANGSU CHANGJING ELECTRONICS TECHNOLOGY CO., LTD.