

**TO-252-2L Plastic-Encapsulate Voltage Regulator**

**CJ7906** Three-terminal negative voltage regulator

**FEATURES**

- Maximum output current  
 $I_{OM}$ : 1.5 A
- Output voltage  
 $V_O$ : -6V
- Continuous total dissipation  
 $P_D$ : 1.5 W ( $T_a = 25^\circ\text{C}$ )

**MARKING**

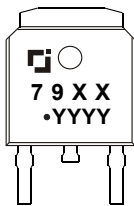

79XX: Device code

Solid Dot: Green molding compound device. If none, the normal device

YYYY: Code

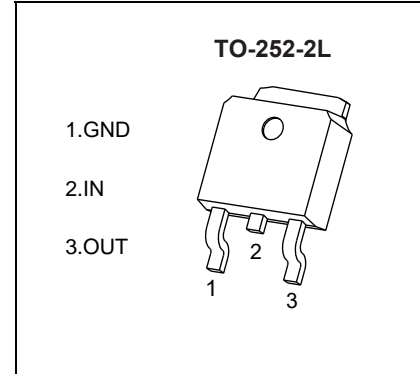

**ABSOLUTE MAXIMUM RATINGS (Operating temperature range applies unless otherwise specified)**

Parameter	Symbol	Value	Unit
Input Voltage	$V_i$	-35	V
Thermal Resistance from Junction to Air	$R_{\theta JA}$	83.3	$^\circ\text{C}/\text{W}$
Operating Junction Temperature Range	$T_{OPR}$	-40~+125	$^\circ\text{C}$
Storage Temperature Range	$T_{STG}$	-65~+150	$^\circ\text{C}$

**ELECTRICAL CHARACTERISTICS AT SPECIFIED VIRTUAL JUNCTION TEMPERATURE ( $V_i = -11\text{V}$ ,  $I_o = 500\text{mA}$ ,  $C_i = 2.2\mu\text{F}$ ,  $C_o = 1\mu\text{F}$ , unless otherwise specified)**

Parameter	Symbol	Test conditions	Min	Typ	Max	Unit
Output Voltage	$V_o$	$T_J = 25^\circ\text{C}$	-5.82	-6	-6.18	V
		$-8\text{V} \leq V_i \leq -21\text{V}$ , $I_o = 5\text{mA} - 1\text{A}$	-5.7	-6	-6.3	V
Load Regulation	$\Delta V_o$	$I_o = 5\text{mA} - 1.5\text{A}$ , $T_J = 25^\circ\text{C}$		15	120	mV
		$I_o = 250\text{mA} - 750\text{mA}$ , $T_J = 25^\circ\text{C}$		5	60	mV
Line Regulation	$\Delta V_o$	$-8\text{V} \leq V_i \leq -25\text{V}$ , $T_J = 25^\circ\text{C}$		12.5	120	mV
		$-9\text{V} \leq V_i \leq -13\text{V}$ , $T_J = 25^\circ\text{C}$		4	60	mV
Quiescent Current	$I_q$	$T_J = 25^\circ\text{C}$		1.5	2	mA
Quiescent Current Change	$\Delta I_q$	$-8\text{V} \leq V_i \leq -25\text{V}$			1.3	mA
	$\Delta I_q$	$5\text{mA} \leq I_o \leq 1\text{A}$			0.5	mA
Output Noise Voltage	$V_N$	$10\text{Hz} \leq f \leq 100\text{KHz}$ , $T_J = 25^\circ\text{C}$		150		$\mu\text{V}/V_o$
Output Voltage Drift	$\Delta V_o/\Delta T$	$I_o = 5\text{mA}$		-0.4		$\text{mV}/^\circ\text{C}$
Ripple Rejection	RR	$-9\text{V} \leq V_i \leq -19\text{V}$ , $f = 120\text{Hz}$	54	60		dB
Dropout Voltage	$V_d$	$I_o = 1\text{A}$ , $T_J = 25^\circ\text{C}$		1.1		V
Peak Current	$I_{pk}$	$T_J = 25^\circ\text{C}$		2.1		A

\* Pulse test.

**TYPICAL APPLICATION**

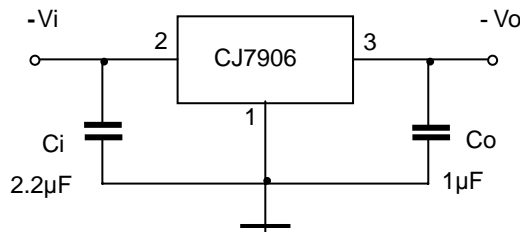

## TO-252-2L Mechanical Information

### TO-252-2L Outlines Dimensions

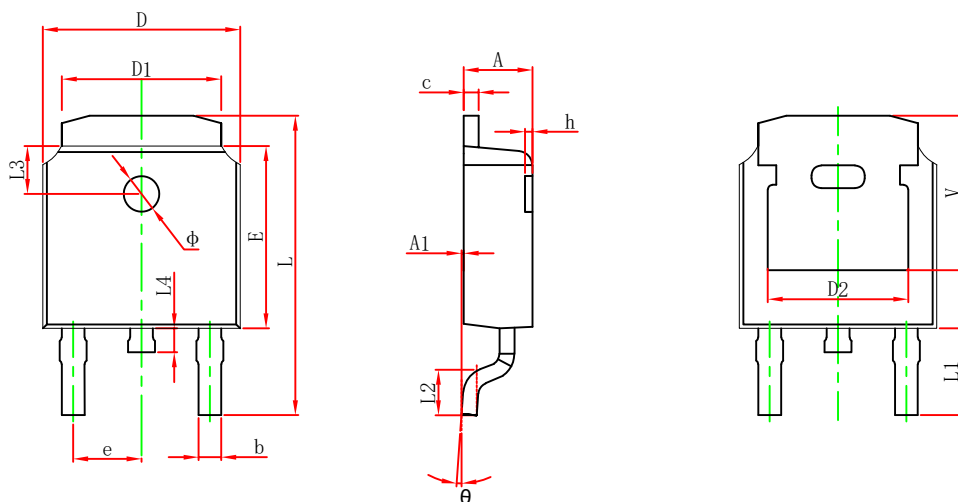

Symbol	Dimensions In Millimeters		Dimensions In Inches	
	Min.	Max.	Min.	Max.
A	2.200	2.400	0.087	0.094
A1	0.000	0.127	0.000	0.005
b	0.635	0.770	0.025	0.030
c	0.460	0.580	0.018	0.023
D	6.500	6.700	0.256	0.264
D1	5.100	5.460	0.201	0.215
D2	4.830 REF.		0.190 REF.	
E	6.000	6.200	0.236	0.244
e	2.186	2.386	0.086	0.094
L	9.712	10.312	0.382	0.406
L1	2.900 REF.		0.114 REF.	
L2	1.400	1.700	0.055	0.067
L3	1.600 REF.		0.063 REF.	
L4	0.600	1.000	0.024	0.039
phi	1.100	1.300	0.043	0.051
theta	0°	8°	0°	8°
h	0.000	0.300	0.000	0.012
V	5.250 REF.		0.207 REF.	

### TO-252-2L Suggest Pad Layout

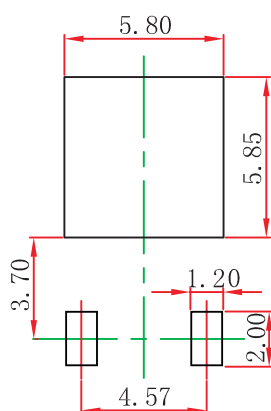

**NOTE:**

1. Controlling dimension: in millimeters.
2. General tolerance:  $\pm 0.05\text{mm}$ .
3. The pad layout is for reference purposes only.

## TO-252-2L Tape and Reel Information

### TO-252-2L Embossed Carrier Tape

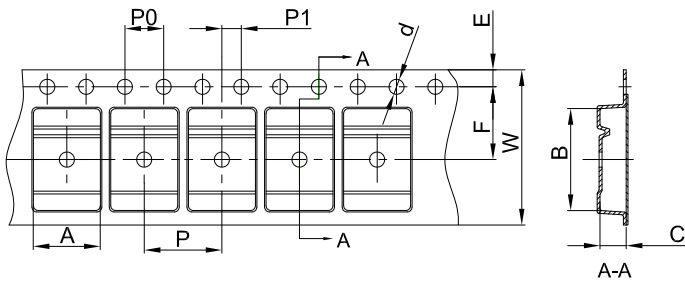

**Packaging Description:**

TO-252 parts are shipped in tape. The carrier tape is made from a dissipative (carbon filled) polycarbonate resin. The cover tape is a multilayer film (Heat Activated Adhesive in nature) primarily composed of polyester film, adhesive layer, sealant, and anti-static sprayed agent. These reeled parts in standard option are shipped with 25,00 units per 13" or 33.0 cm diameter reel. The reels are clear in color and is made of polystyrene plastic (anti-static coated).

Dimensions are in millimeter

Pkg type	A	B	C	d	E	F	P0	P	P1	W
TO-252	6.90	10.50	2.70	Ø1.55	1.75	7.50	4.00	8.00	2.00	16.00

### TO-252 Tape Leader and Trailer

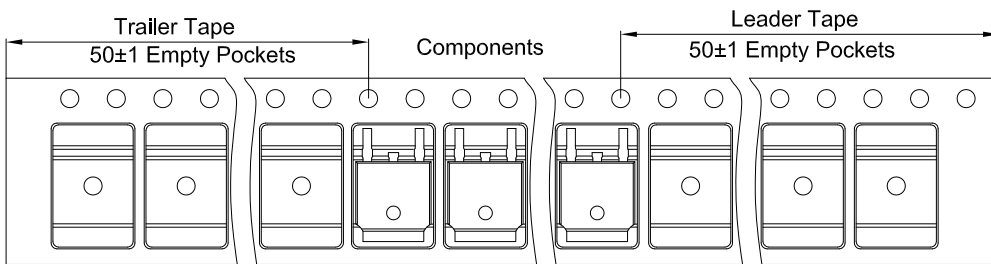

### TO-252 Reel

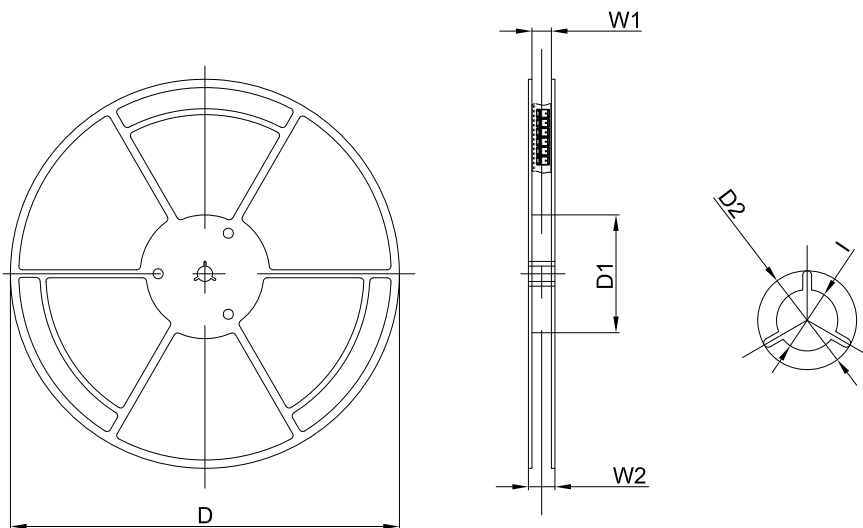

Dimensions are in millimeter

Reel Option	D	D1	D2	W1	W2	I
13" Dia	330.00	100.00	Ø21.00	16.40	21.00	Ø13.00

REEL	Reel Size	Box	Box Size(mm)	Carton	Carton Size(mm)	G.W.(kg)
2,500 pcs	13inch	2,500 pcs	340×336×29	25,000 pcs	353×346×365	

# TO-252-2L Tape and Reel

## TO-252-2L Embossed Carrier Tape



### Packaging Description:

TO-252-2L parts are shipped in tape. The carrier tape is made from a dissipative (carbon filled) polycarbonate resin. The cover tape is a multilayer film (Hear Activated Adhesive in nature) primarily composed of polyester film, adhesive layer, sealant, and anti-static sprayed agent. These reeled parts in standard option are shipped with 2500 units per 13" or 33.0 cm diameter reel. The reels are clear in color and is made of polystyrene plastic (anti-static coated).

Dimensions are in millimeter										
Pkg type	A	B	C	d	E	F	P0	P	P1	W
TO-252	6.90	10.50	2.70	Φ1.55	1.75	7.50	4.00	8.00	2.00	16.00

## TO-252-2L Tape Leader and Trailer

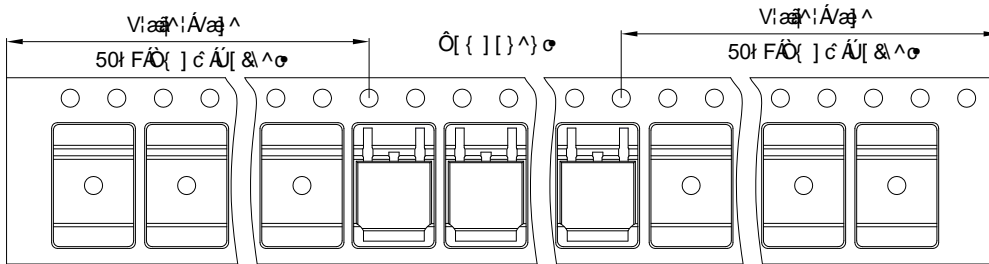

## TO-252-2L Reel

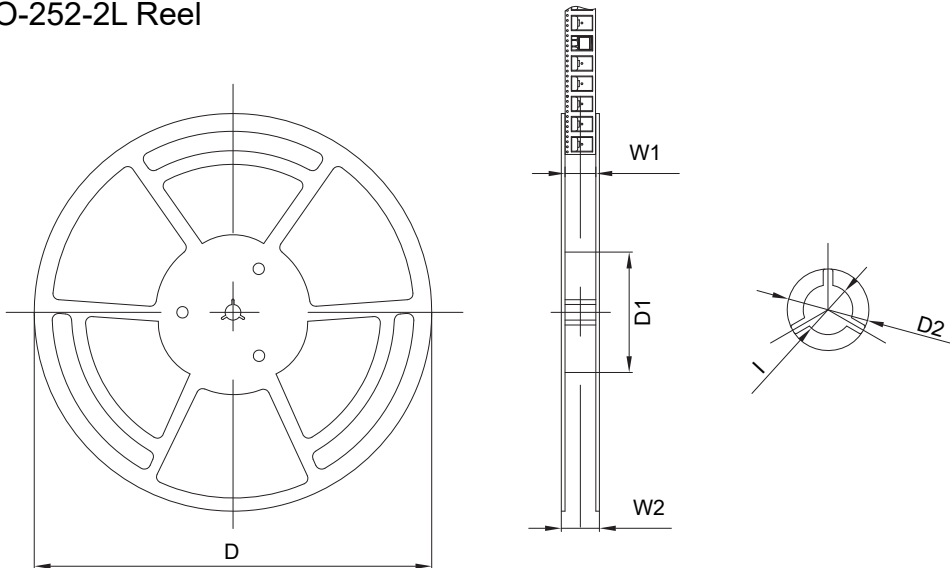

Dimensions are in millimeter						
Reel	D	D1	D2	W1	W2	l
13" Dia	330.00	100.00	Φ21.00	16.40	21.40	Φ13.00

Reel	Reel Size	Box	Box Size(mm)	Carton	Carton Size(mm)
2500 pcs	13 inch	5000 pcs	360×360×65	25000 pcs	378×358×382