



## CJ809 Series

### ■ INTRODUCTION

The CJ809 Series is a series of high-precision voltage detectors with a built-in delay time generator of fixed time, developed using CMOS process.

The detection voltage is fixed internally, with an accuracy of  $\pm 2.0\%$ . Internal oscillator and counter timer can delay the release signal without external parts, delay times 200 ms Two output forms, NMOS open-drain and CMOS output are available.

### ■ APPLICATIONS

- Memory battery back-up circuits
- Power-on reset circuits
- Power failure detection
- Power monitor for portable equipment such as notebook computers, digital cameras, PDA, and cellular phones.
- Constant voltage power monitors for cameras, video equipment and communication devices.
- Power monitor for microcomputers and reset for CPUs.

### ■ FEATURES

- Ultra-low current consumption:  
0.9 $\mu$ A@3.5V(Typ.)
- High-precision detection voltage:  $\pm 2.0\%$
- Hysteresis characteristics:  $-V_{DET} \times 5\%$ (Typ.)
- Operating voltage range: 0.95V to 7.0V
- Detection voltage: 1.5V to 6.0V (10mV step)
- Delay time: 210 ms (Typ.)
- Output forms:  
NMOS open-drain output (Active Low)  
CMOS output (Active Low)

### ■ ORDER INFORMATION

#### CJ809 ①②③④⑤

DESIGNATOR	SYMBOL	DESCRIPTION
①	C	CMOS
	N	NMOS open drain
②③④	Integer	Detection Voltage “④”elide when it is “0” e.g. 3.0V=②:3, ③:0 2.93V=②:2, ③:9, ④:3
⑤	M	Package: SOT-23-3L
	P	Package: SOT-89-3L
	N	Package: SOT-23

## ■ BLOCK DIAGRAMS

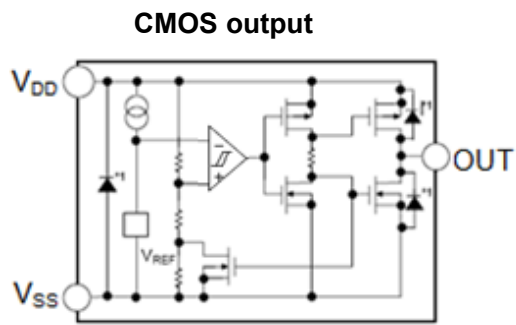
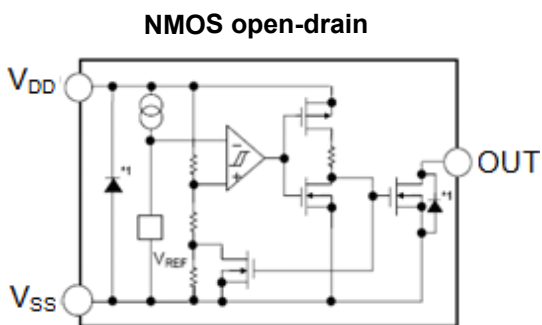

## ■ PIN CONFIGURATION

**SOT-23**  
**SOT-23-3L**

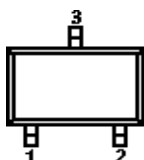

PIN NO.	N/M	FUNCTION
1	$V_{SS}$	Ground
2	$V_{OUT}$	Voltage detection output pin
3	$V_{DD}$	Voltage input pin

**SOT-89-3L**

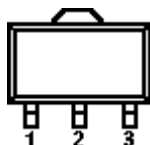

PIN NO.	P	FUNCTION
1	$V_{OUT}$	Voltage detection output pin
2	$V_{DD}$	Voltage input pin
3	$V_{SS}$	Ground

## Electrical Characteristics

### ■ ABSOLUTE MAXIMUM RATINGS

(Ta=25°C, unless otherwise specified)

PARAMETER		SYMBOL	RATINGS	UNITS
Power supply voltage		V <sub>DD</sub>	V <sub>SS</sub> -0.3 ~ V <sub>SS</sub> +8	V
Output voltage		V <sub>OUT</sub>	V <sub>SS</sub> -0.3 ~ V <sub>SS</sub> +8	V
Power dissipation	SOT-23-3L	PD	250	mW
	SOT-89-3L		600	
	SOT-23		200	
Operating ambient temperature		T <sub>opr</sub>	-40 ~ +85	°C
Storage temperature		T <sub>stg</sub>	-40 ~ +125	°C
Soldering Temperature & Time		T <sub>solder</sub>	260°C, 10s	

### ■ ELECTRICAL CHARACTERISTICS

(Ta=25°C, unless otherwise specified)

PARAMETER	SYMBOL	CONDITIONS		MIN	TYP	MAX	UNITS
Detection voltage*1	-V <sub>DET</sub>	—		-V <sub>DET(S)</sub> ×0.98	-V <sub>DET(S)</sub>	-V <sub>DET(S)</sub> ×1.02	V
Hysteresis width	V <sub>HYS</sub>	—		0.02× -V <sub>DET(S)</sub>	0.05× -V <sub>DET(S)</sub>	0.08× -V <sub>DET(S)</sub>	V
Current consumption	I <sub>SS</sub>	V <sub>DD</sub> = -V <sub>DET</sub> +0.5V	C/N20~26	—	1.0	3.0	uA
			C/N 26~39	—	1.2	3.2	uA
			C/N 39~60	—	1.5	3.5	uA
Operating voltage	V <sub>DD</sub>	—		0.95	—	7	V
Output current	I <sub>OUT</sub>	NMOS: V <sub>OUT</sub> =0.5 V V <sub>DD</sub> =-V <sub>DET</sub> +0.5V	C/N 20~26	3.0	13.0	—	mA
			C/N 26~39	3.0	15.0	—	mA
			C/N 39~60	3.0	18.0	—	mA
		PMOS: V <sub>DD</sub> -V <sub>OUT</sub> =0.5 V V <sub>DD</sub> =-V <sub>DET</sub> -0.5 V	C/N 20~26	1.5	4.0	—	mA
			C/N 26~39	1.5	6.0	—	mA
			C/N 39~60	1.5	8.0	—	mA
Leakage current	I <sub>LEAK</sub>	Only for NMOS open-drain output products, V <sub>DD</sub> =6.0 V, V <sub>OUT</sub> =6.0 V			—	1.0	uA
temperature coefficient		Ta=-40°C ~+85°C		—	±120	±360	ppm/°C
Delay time	T <sub>PLH</sub>			130	210	290	ms

\*1. -V<sub>DET</sub>: Actual detection voltage value, -V<sub>DET(S)</sub>: Specified detection voltage value

## ■ TYPICAL APPLICATION CIRCUITS

### 1、CMOS output:

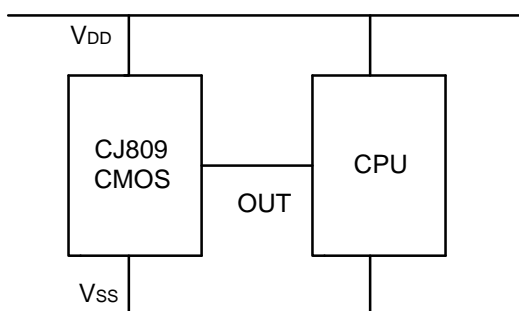

### 2、NMOS open-drain

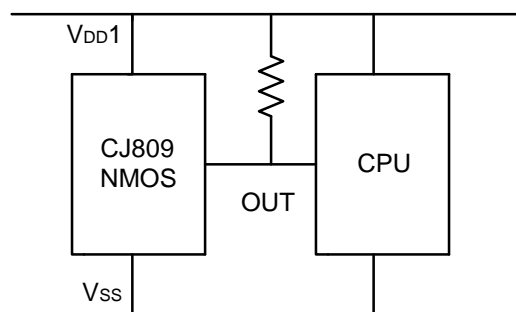
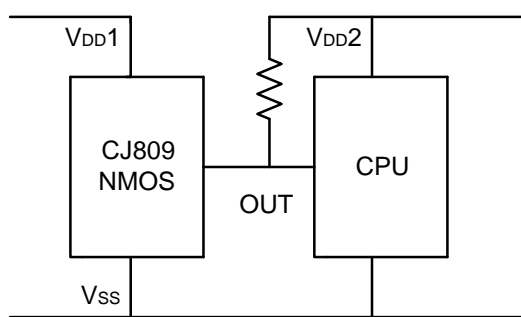

### 3. Forbidden Circuits

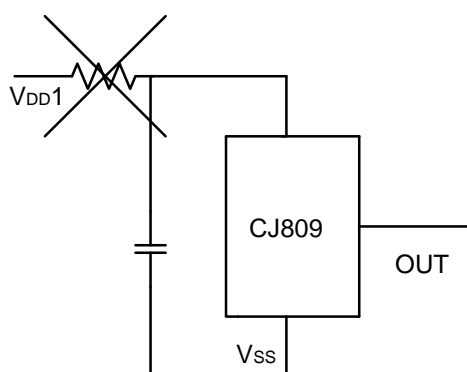

## SOT-23 Package Outline Dimensions

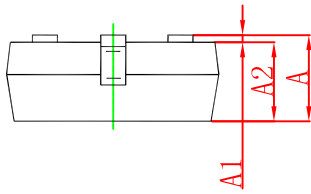
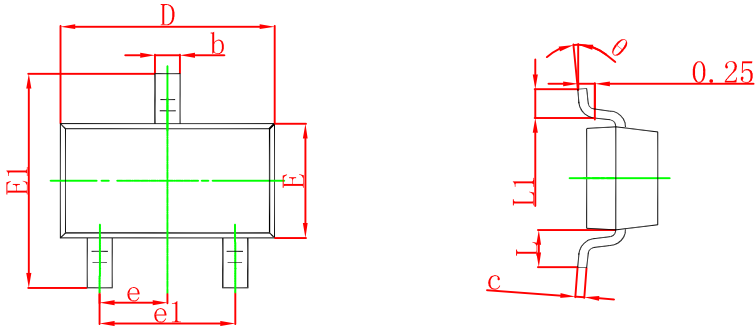

Symbol	Dimensions In Millimeters		Dimensions In Inches	
	Min.	Max.	Min.	Max.
A	0.900	1.150	0.035	0.045
A1	0.000	0.100	0.000	0.004
A2	0.900	1.050	0.035	0.041
b	0.300	0.500	0.012	0.020
c	0.080	0.150	0.003	0.006
D	2.800	3.000	0.110	0.118
E	1.200	1.400	0.047	0.055
E1	2.250	2.550	0.089	0.100
e	0.950 TYP.		0.037 TYP.	
e1	1.800	2.000	0.071	0.079
L	0.550 REF.		0.022 REF.	
L1	0.300	0.500	0.012	0.020
$\theta$	0°	8°	0°	8°

## SOT-23 Suggested Pad Layout

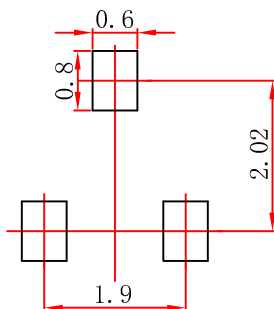

Note:

1. Controlling dimension: in millimeters.
2. General tolerance:  $\pm 0.05$  mm.
3. The pad layout is for reference purposes only.

## SOT-23-3L Package Outline Dimensions

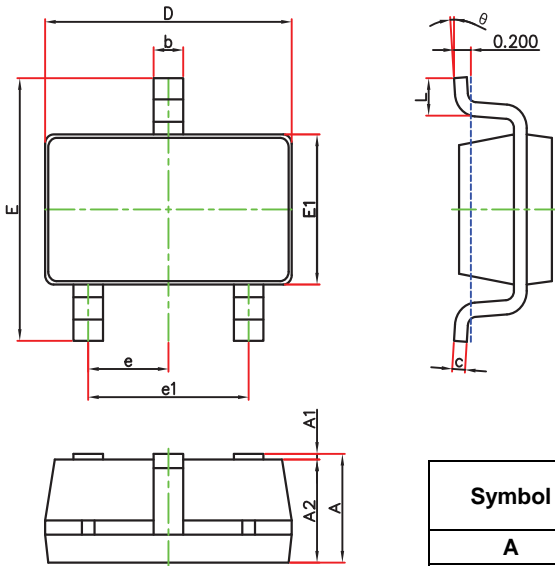

Symbol	Dimensions In Millimeters		Dimensions In Inches	
	Min.	Max.	Min.	Max.
A	1.050	1.250	0.041	0.049
A1	0.000	0.100	0.000	0.004
A2	1.050	1.150	0.041	0.045
b	0.300	0.500	0.012	0.020
c	0.100	0.200	0.004	0.008
D	2.820	3.020	0.111	0.119
E	2.650	2.950	0.104	0.116
E1	1.500	1.700	0.059	0.067
e	0.950(BSC)		0.037(BSC)	
e1	1.800	2.000	0.071	0.079
L	0.300	0.600	0.012	0.024
θ	0°	8°	0°	8°

## SOT-23-3L Suggested Pad Layout

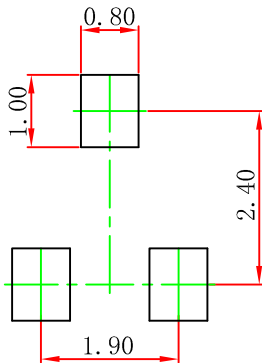

Note:

1. Controlling dimension: in millimeters.
2. General tolerance:  $\pm 0.05\text{mm}$ .
3. The pad layout is for reference purposes only.

## SOT-89-3L Package Outline Dimensions

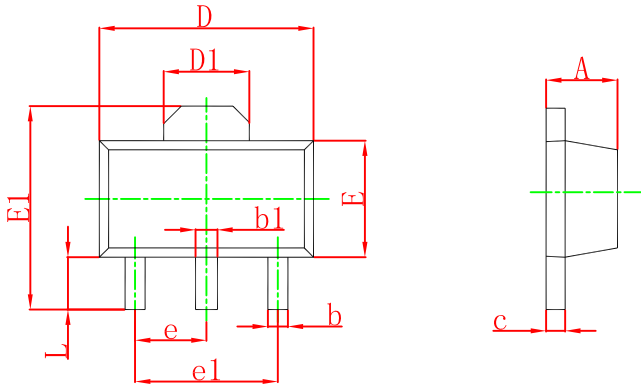

Symbol	Dimensions In Millimeters		Dimensions In Inches	
	Min.	Max.	Min.	Max.
A	1.400	1.600	0.055	0.063
b	0.320	0.520	0.013	0.197
b1	0.400	0.580	0.016	0.023
c	0.350	0.440	0.014	0.017
D	4.400	4.600	0.173	0.181
D1	1.550 REF		0.061 REF	
E	2.300	2.600	0.091	0.102
E1	3.940	4.250	0.155	0.167
e	1.500 TYP		0.060 TYP	
e1	3.000 TYP		0.118 TYP	
L	0.900	1.200	0.035	0.047

## SOT-89-3L Suggested Pad Layout

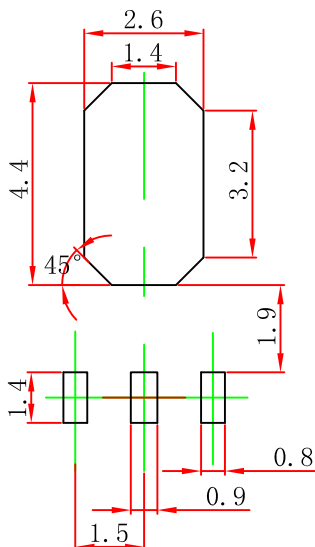

- Note:
1. Controlling dimension: in millimeters.
  2. General tolerance:  $\pm 0.05$  mm.
  3. The pad layout is for reference purposes only.

# DISCLAIMER

## **IMPORTANT NOTICE, PLEASE READ CAREFULLY**

The information in this data sheet is intended to describe the operation and characteristics of our products. JSCJ has the right to make any modification, enhancement, improvement, correction or other changes to any content in this data sheet, including but not limited to specification parameters, circuit design and application information, without prior notice.

Any person who purchases or uses JSCJ products for design shall: 1. Select products suitable for circuit application and design; 2. Design, verify and test the rationality of circuit design; 3. Procedures to ensure that the design complies with relevant laws and regulations and the requirements of such laws and regulations. JSCJ makes no warranty or representation as to the accuracy or completeness of the information contained in this data sheet and assumes no responsibility for the application or use of any of the products described in this data sheet.

Without the written consent of JSCJ, this product shall not be used in occasions requiring high quality or high reliability, including but not limited to the following occasions: medical equipment, automotive electronics, military facilities and aerospace. JSCJ shall not be responsible for casualties or property losses caused by abnormal use or application of this product.

Official Website: [www.jscj-elec.com](http://www.jscj-elec.com)

Copyright © JIANGSU CHANGJING ELECTRONICS TECHNOLOGY CO., LTD.