

## CJ9107 Series

### ■ INTRODUCTION

The CJ9107 Series is a Synchronous step-up DC/DC Converter with PFM Control.

With the CJ9107 Series, a step-up switching DC/DC converter can be configured by using an external coil, capacitor. The built-in MOSFET is turned off by a protection circuit when the voltage at the LX pin exceeds the limit to prevent it from being damaged.

### ■ APPLICATIONS

- Digital cameras
- Electronic notebooks and PDAs
- Portable CD/MD players

### ■ BLOCK DIAGRAM

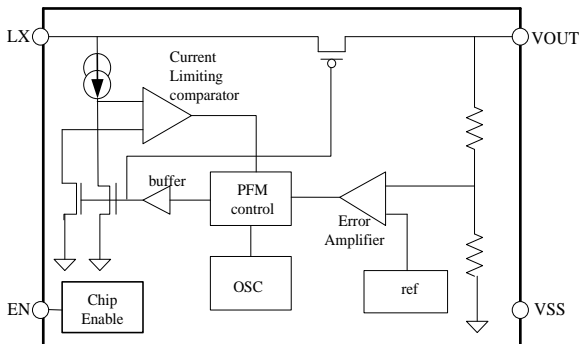

### ■ FEATURES

- External parts: Coil, capacitor
- Output voltage: Settable to between 2.1V to 5.5 V in 0.1 V steps
- Maximum Oscillation frequency: 300KHz
- Accuracy of  $\pm 2\%$
- High efficiency: 95%

- Cameras, video equipment,
- Communications equipment
- Power supply for microcomputers

### ■ DEVICE INFORMATION:

#### CJ9107 ①②③④

DESIGNATOR	SYMBOL	DESCRIPTION
①	A	Standard LX
	B	With shutdown, LX
②③	Integer	Output Voltage (2.1~5.5) e.g.: 3.0V=②:3; ③:0
④	T3/T5	Package: SOT-23-3/5L
	K	Package: SOT-23
	R	Package: SOT-89-3L
	L	Package: TO-92

# Pin Configuration

SOT-23  
SOT-23-3L  
Top view

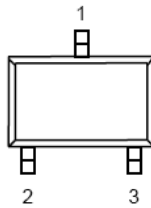

**Table 1 CJ9107A Series (SOT-23-3L/SOT-23 PKG)**

PIN NO.	PIN NAME	FUNCTION
1	$V_{OUT}$	Output voltage pin
2	$V_{SS}$	GND pin
3	LX	External inductor connection pin

SOT-23-5L  
Top view

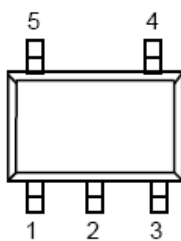

**Table 2 CJ9107B Series (SOT-23-5L PKG)**

PIN NO.	PIN NAME	FUNCTION
1	EN	Shutdown pin “H”: Normal operation “L”: Step-up stopped
2	$V_{OUT}$	Output voltage pin
3	NC	(N.C.)
4	$V_{SS}$	GND pin
5	LX	External inductor connection pin

SOT-89-3L  
Top view

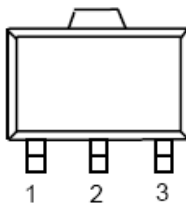

**Table 3 CJ9107A Series (SOT-89-3L PKG)**

PIN NO.	PIN NAME	FUNCTION
1	$V_{SS}$	GND pin
2	$V_{OUT}$	Output voltage pin
3	LX	External inductor connection pin

TO-92  
Bottom view

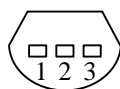

**Table 4 CJ9107A Series (TO-92 PKG)**

PIN NO.	PIN NAME	FUNCTION
1	$V_{SS}$	GND pin
2	$V_{OUT}$	Output voltage pin
3	LX	External inductor connection pin

## Electrical Characteristics

### ■ ABSOLUTE MAXIMUM RATINGS (Unless otherwise specified, Ta=25°C)

PARAMETER		SYMBOL	RATINGS	UNITS
V <sub>OUT</sub> Pin Voltage		V <sub>OUT</sub>	V <sub>SS</sub> -0.3 ~ V <sub>SS</sub> +8	V
EN Pin Voltage		EN	V <sub>SS</sub> -0.3 ~ V <sub>SS</sub> +8	V
LX Pin Voltage		V <sub>LX</sub>	V <sub>SS</sub> -0.3 ~ V <sub>SS</sub> +8	V
LX Pin Current		I <sub>LX</sub>	1000	mA
Power Dissipation	SOT-23	PD	250	mW
	SOT23-3/5L		250	mW
	SOT-89-3L		500	mW
	TO-92		500	mW
Operating Temperature		T <sub>opr</sub>	-40 ~+85	°C
Storage Temperature		T <sub>stg</sub>	-40 ~+125	°C
Soldering Temperature & Time		T <sub>solder</sub>	260°C, 10s	

### ■ ELECTRICAL CHARACTERISTICS (Unless otherwise specified, Ta=25°C)

PARAMETER	SYMBOL	CONDITIONS	MIN	TYP	MAX	UNITS
Output Voltage	V <sub>OUT</sub>	—	V <sub>OUT(S)</sub> x0.98	V <sub>OUT</sub>	V <sub>OUT(S)</sub> x1.02	V
Input Voltage	V <sub>IN</sub>	—	—	—	5	V
Operation Start Voltage	V <sub>ST1</sub>	I <sub>OUT</sub> = 1 mA	—	—	0.9	V
Input Current At No Load	I <sub>SS</sub>	V <sub>IN</sub> =1.8V, V <sub>OUT</sub> =3.0V	—	15	-	μA
Current Consumption 2	I <sub>SS2</sub>	V <sub>OUT</sub> =V <sub>OUT</sub> +0.5 V	—	6	10	μA
Current Consumption During Shutdown	I <sub>SSS</sub>	V <sub>EN</sub> = 0 V	—	—	1.0	μA
Maximum Oscillation Frequency	f <sub>OSC</sub>	V <sub>OUT</sub> = 0.95xV <sub>OUT</sub> , measure waveform at LX pin	—	300	—	KHz
Duty Ratio 1	Duty1	V <sub>OUT</sub> = 0.95xV <sub>OUT</sub> , measure waveform at LX pin	70	78	85	%
Efficiency	EFFI	—	—	90	—	%
Shutdown Pin Input Voltage	V <sub>SH</sub>	V <sub>OUT</sub> =0.95xV <sub>OUT</sub> , judge oscillation at LX pin	0.75	—	—	V
	V <sub>SL1</sub>	V <sub>OUT</sub> = 0.95xV <sub>OUT</sub> , judge stop at LX pin	—	—	0.3	V
Shutdown Pin Input Current	I <sub>SH</sub>	V <sub>EN</sub> =6V	-0.1	—	0.1	μA
	I <sub>SL</sub>	V <sub>EN</sub> =0V	-0.1	—	0.1	μA

Remark: V<sub>OUT(S)</sub> specified above is the set output voltage value, and V<sub>OUT</sub> is the typical value of the actual output voltage.

---

## Typical Characteristics

---

### ■ STANDARD CIRCUITS

Component: Inductor: 47uH(Sumida)

Capacitor: 47uF/16V(Tantalum)

#### 1、 CJ9107A:

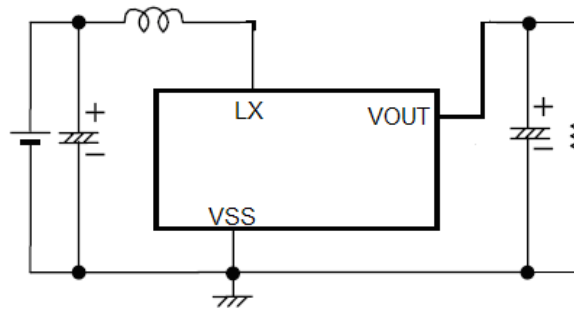

#### 2、 CJ9107B:

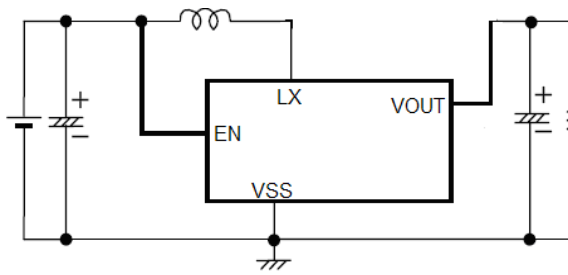

# Typical Characteristics

$C_{in}=C_{out}=100\mu F$

$L=47\mu H$

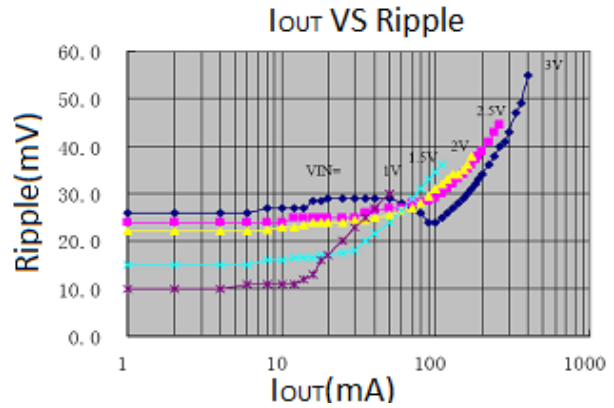
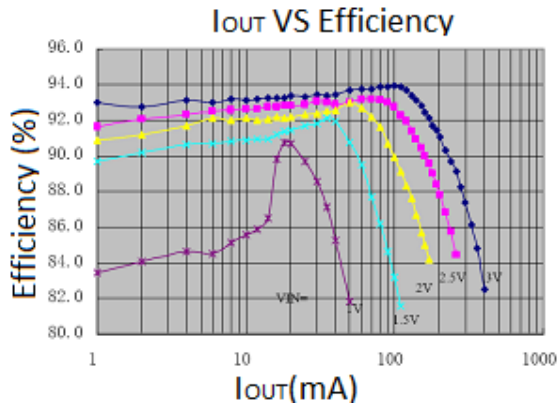
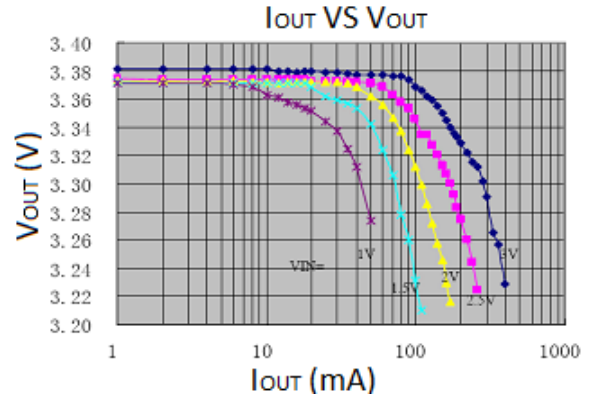
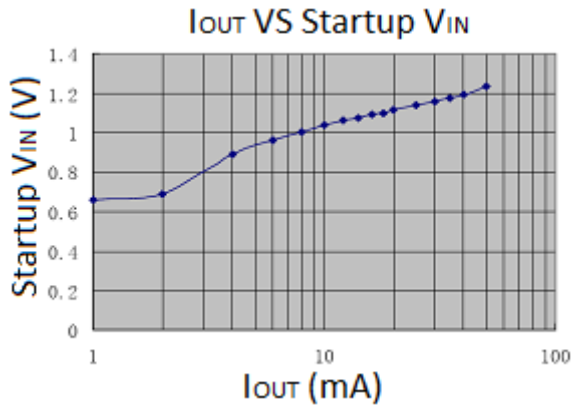

# SOT-23 Package Outline Dimensions

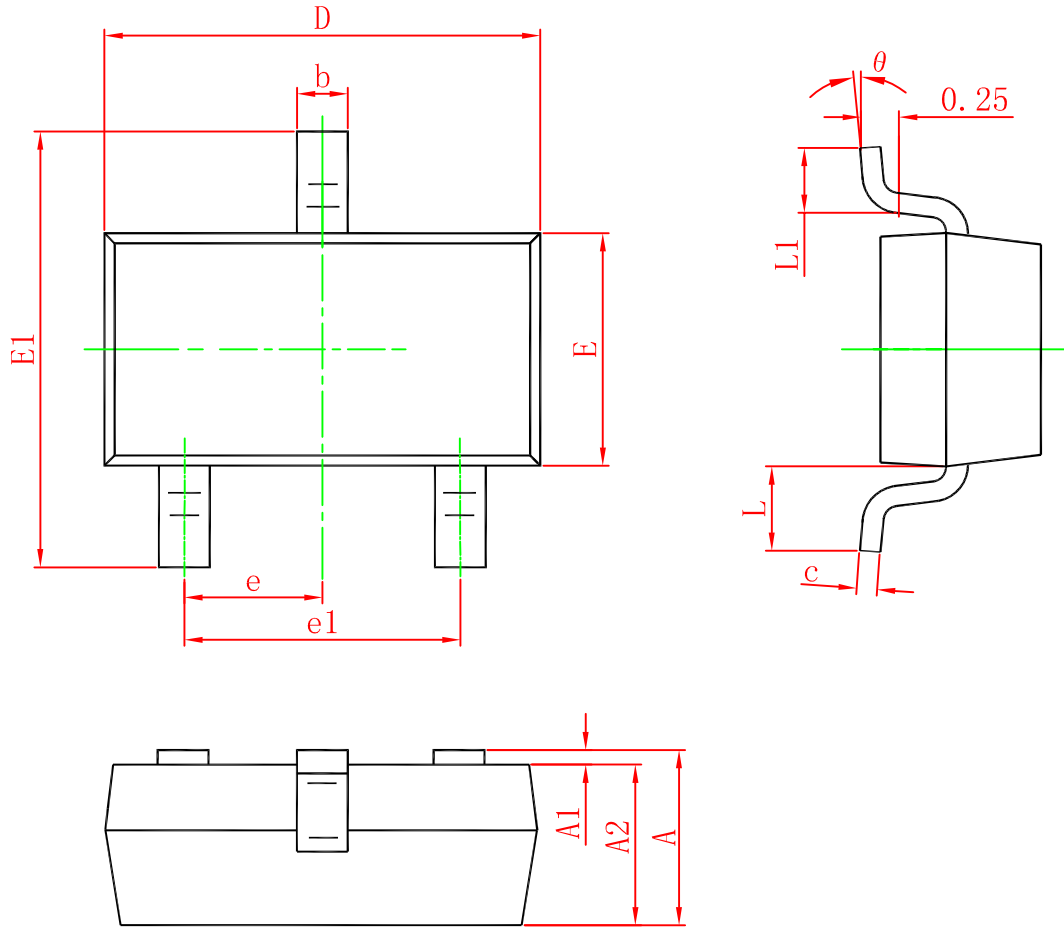

Symbol	Dimensions In Millimeters		Dimensions In Inches	
	Min.	Max.	Min.	Max.
A	0.900	1.150	0.035	0.045
A1	0.000	0.100	0.000	0.004
A2	0.900	1.050	0.035	0.041
b	0.300	0.500	0.012	0.020
c	0.080	0.150	0.003	0.006
D	2.800	3.000	0.110	0.118
E	1.200	1.400	0.047	0.055
E1	2.250	2.550	0.089	0.100
e	0.950 TYP.		0.037 TYP.	
e1	1.800	2.000	0.071	0.079
L	0.550 REF.		0.022 REF.	
L1	0.300	0.500	0.012	0.020
$\theta$	0°	8°	0°	8°

## SOT-23-3L Package Outline Dimensions

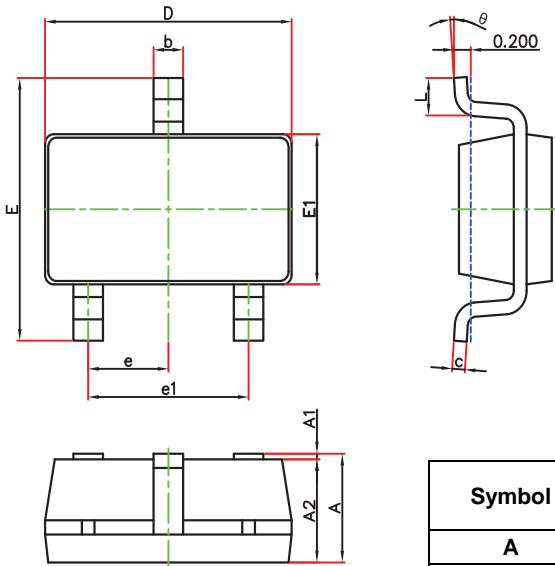

Symbol	Dimensions In Millimeters		Dimensions In Inches	
	Min.	Max.	Min.	Max.
A	1.050	1.250	0.041	0.049
A1	0.000	0.100	0.000	0.004
A2	1.050	1.150	0.041	0.045
b	0.300	0.500	0.012	0.020
c	0.100	0.200	0.004	0.008
D	2.820	3.020	0.111	0.119
E	1.500	1.700	0.059	0.067
E1	2.650	2.950	0.104	0.116
e	0.950(BSC)		0.037(BSC)	
e1	1.800	2.000	0.071	0.079
L	0.300	0.600	0.012	0.024
θ	0°	8°	0°	8°

## SOT-23-3L Suggested Pad Layout

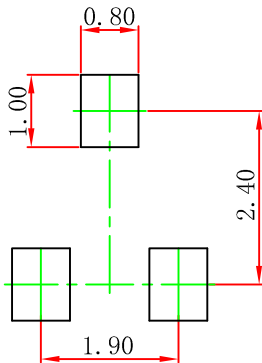

- Note:
1. Controlling dimension: in millimeters.
  2. General tolerance:  $\pm 0.05\text{mm}$ .
  3. The pad layout is for reference purposes only.

## SOT-23-5L Package Outline Dimensions

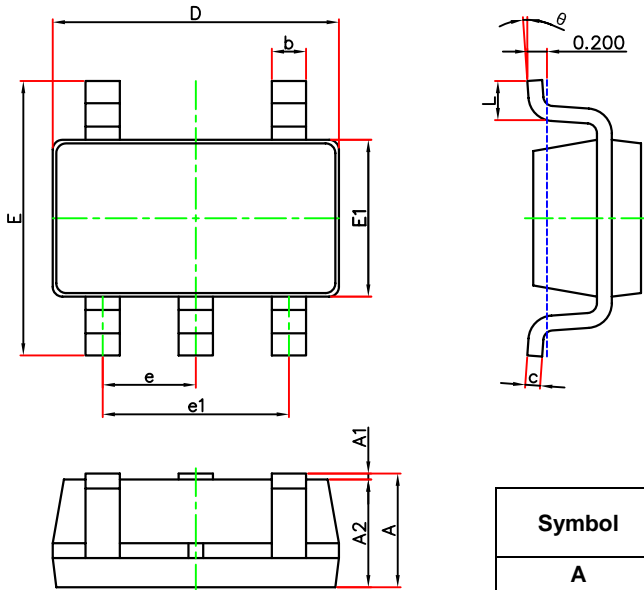

Symbol	Dimensions In Millimeters		Dimensions In Inches	
	Min.	Max.	Min.	Max.
A	1.050	1.250	0.041	0.049
A1	0.000	0.100	0.000	0.004
A2	1.050	1.150	0.041	0.045
b	0.300	0.500	0.012	0.020
c	0.100	0.200	0.004	0.008
D	2.820	3.020	0.111	0.119
E	1.500	1.700	0.059	0.067
E1	2.650	2.950	0.104	0.116
e	0.950(BSC)		0.037(BSC)	
e1	1.800	2.000	0.071	0.079
L	0.300	0.600	0.012	0.024
theta	0°	8°	0°	8°

## SOT-23-5L Suggested Pad Layout

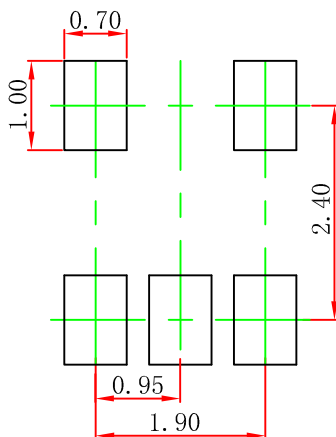

Note:

1. Controlling dimension; in millimeters.
2. General tolerance:  $\pm 0.05\text{mm}$ .
3. The pad layout is for reference purposes only.

## SOT-89-3L Package Outline Dimensions

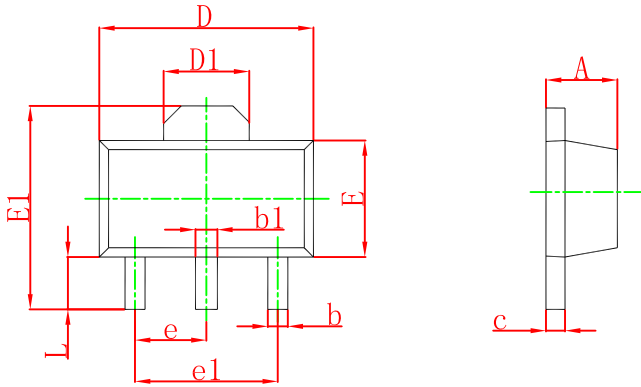

Symbol	Dimensions In Millimeters		Dimensions In Inches	
	Min.	Max.	Min.	Max.
A	1.400	1.600	0.055	0.063
b	0.320	0.520	0.013	0.197
b1	0.400	0.580	0.016	0.023
c	0.350	0.440	0.014	0.017
D	4.400	4.600	0.173	0.181
D1	1.550 REF		0.061 REF	
E	2.300	2.600	0.091	0.102
E1	3.940	4.250	0.155	0.167
e	1.500 TYP		0.060 TYP	
e1	3.000 TYP		0.118 TYP	
L	0.900	1.200	0.035	0.047

## SOT-89-3L Suggested Pad Layout

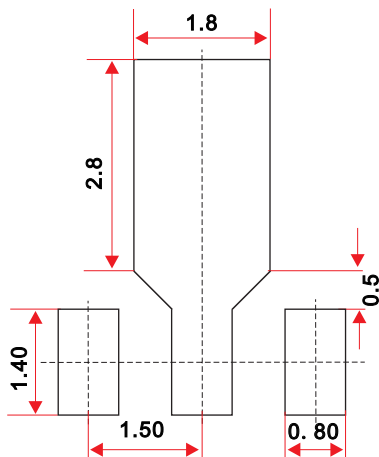

- Note:
1. Controlling dimension: in millimeters.
  2. General tolerance:  $\pm 0.05$  mm.
  3. The pad layout is for reference purposes only.



# DISCLAIMER

## **IMPORTANT NOTICE, PLEASE READ CAREFULLY**

The information in this data sheet is intended to describe the operation and characteristics of our products. JSCJ has the right to make any modification, enhancement, improvement, correction or other changes to any content in this data sheet, including but not limited to specification parameters, circuit design and application information, without prior notice.

Any person who purchases or uses JSCJ products for design shall: 1. Select products suitable for circuit application and design; 2. Design, verify and test the rationality of circuit design; 3. Procedures to ensure that the design complies with relevant laws and regulations and the requirements of such laws and regulations. JSCJ makes no warranty or representation as to the accuracy or completeness of the information contained in this data sheet and assumes no responsibility for the application or use of any of the products described in this data sheet.

Without the written consent of JSCJ, this product shall not be used in occasions requiring high quality or high reliability, including but not limited to the following occasions: medical equipment, automotive electronics, military facilities and aerospace. JSCJ shall not be responsible for casualties or property losses caused by abnormal use or application of this product.

Official Website: [www.jscj-elec.com](http://www.jscj-elec.com)

Copyright © JIANGSU CHANGJING ELECTRONICS TECHNOLOGY CO., LTD.