

CJAB2003A N-Channel + P-Channel MOSFET

V _{(BR)DSS}	R _{DS(on)} TYP	I _D
30V	8.5mΩ@10V	30A
	10.7mΩ@4.5V	
-30V	28mΩ@-10V	-20A
	35mΩ@-4.5V	

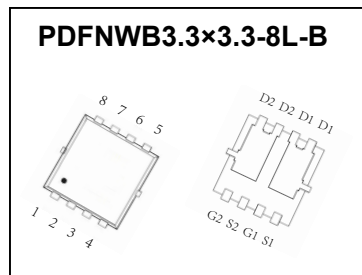

DESCRIPTION

The CJAB2003A uses advanced trench technology and design to provide excellent R_{DS(ON)} with low gate charge. It can be used in a wide variety of applications

FEATURES

- Battery switch
- Load switch
- High density cell design for ultra low R_{DS(ON)}
- Fully characterized avalanche voltage and current
- Good stability and uniformity with high E_{AS}
- Excellent package for good heat dissipation
- Special process technology for high ESD capability

APPLICATIONS

- SMPS and general purpose applications
- Hard switched and high frequency circuits
- Uninterruptible Power Supply

MARKING

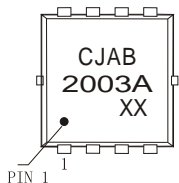

CJAB2003A=Part No.
 Solid dot=Pin1 indicator
 XX=Date Code

EQUIVALENT CIRCUIT

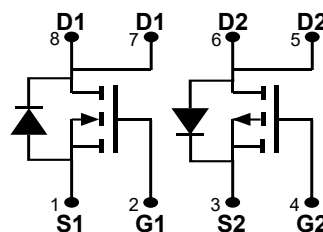

MAXIMUM RATINGS (T_a=25°C unless otherwise noted)

Parameter	Symbol	Limit	Unit
N-MOSFET			
Drain-Source Voltage (V _{GS} =0V, I _D =0A)	V _{DS}	30	V
Drain-Source Voltage (V _{GS} =0V, I _D =30A)	V _{DS}	10	V
Gate-Source Voltage (I _D =0A)	V _{GS}	±30	V
Drain Current (V _{GS} =10V, V _{DS} =0V)	I _D	30	A
Drain Current (V _{GS} =10V, V _{DS} =30V)	I _D	72	mA
P-MOSFET			
Drain-Source Voltage (V _{GS} =0V, I _D =0A)	V _{DS}	30	V
Drain-Source Voltage (V _{GS} =0V, I _D =-20A)	V _{DS}	10	V
Gate-Source Voltage (I _D =0A)	V _{GS}	±30	V
Drain Current (V _{GS} =-10V, V _{DS} =0V)	I _D	20	A
Drain Current (V _{GS} =-10V, V _{DS} =30V)	I _D	51	mA
Temperature and Thermal Resistance			
Storage Temperature Range	T _{STG}	100	°C
Case Temperature Range	T _{RC}	2.3	°C/W
Junction Temperature Range	T _J	150	°C
Maximum Power Dissipation (T _J =25°C)	P _{DM}	1.5	W

MOSFET ELECTRICAL CHARACTERISTICS

N-Channel MOSFET ELECTRICAL CHARACTERISTICS, $T_a=25^\circ\text{C}$ unless otherwise specified

Parameter	Symbol	Test Condition	Min	Typ	Max	Unit
Off characteristics						
Drain current I_{DSS}	I_{DSS}	$V_{GS}=0V$	3	-	-	μA
Gate leakage current I_{GSS}	I_{GSS}	$V_{DS}=0V$	-	-	1	μA
Source leakage current I_{SS}	I_{SS}	$V_{GS}=0V$	-	-	1	μA
On characteristics						
On-state drain current $I_{D(on)}$	$I_{D(on)}$	$V_{GS}=10V$	1	1.8	2.5	A
Switching time $t_{d(on)}$	$t_{d(on)}$	$V_{GS}=10V$	-	8.5	11	μs
		$V_{GS}=14.5V$	-	10.7	16	μs
Dynamic characteristics						
Turn-on delay time $t_{d(on)}$	$t_{d(on)}$	$V_{GS}=10V$ $V_{DS}=10V$ $f=1MHz$	-	1150	-	μs
Turn-off delay time $t_{d(off)}$	$t_{d(off)}$		-	165	-	
Storage time $t_{s(off)}$	$t_{s(off)}$		-	99	-	
Gate resistance	R_g	$f=1MHz$	-	6.0	-	Ω
Switching characteristics						
Switching voltage V_{sw}	V_{sw}	$V_{GS}=14.5V$	-	8.5	-	μA
Switching voltage V_{sw}	V_{sw}	$V_{GS}=10V$ $V_{DS}=10V$ $f=1MHz$	-	17.6	-	
Switching current I_{sw}	I_{sw}		-	3.15	-	
Switching current I_{sw}	I_{sw}		-	3.21	-	
Switching voltage V_{sw}	V_{sw}	$V_{GS}=10V$ $V_{DS}=10V$ $f=1MHz$	-	13	-	μA
Switching voltage V_{sw}	V_{sw}		-	140	-	
Switching current I_{sw}	I_{sw}		-	38	-	
Switching current I_{sw}	I_{sw}		-	85	-	
Drain-Source Diode Characteristics						
Reverse current I_{RS}	I_{RS}	$V_{GS}=0V$	-	-	1	μA
Reverse recovery time t_{rr}	t_{rr}		-	-	30	μs
Storage time t_{st}	t_{st}		-	-	100	μs

MOSFET ELECTRICAL CHARACTERISTICS

P-Channel MOSFET ELECTRICAL CHARACTERISTICS, $T_a=25^\circ\text{C}$ unless otherwise specified

Parameter	Symbol	Test Condition	Min	Typ	Max	Unit
Off characteristics						
Off-state drain current	I_{DSS}	$V_{GS}=0\text{V}$	-	-	-	μA
Off-state drain current (at $V_{GS}=0\text{V}$)	I_{DSS}	$V_{GS}=0\text{V}$	-	-	-	μA
Off-state drain current (at $V_{GS}=0\text{V}$)	I_{DSS}	$V_{GS}=0\text{V}$	-	-	-	μA
On characteristics						
On-state drain current	$I_{D(on)}$	$V_{GS}=10\text{V}$	-	-	-	mA
On-state drain current (at $V_{GS}=10\text{V}$)	$I_{D(on)}$	$V_{DS}=0\text{V}$	-	28	H6	{ δ
		$V_{DS}=10\text{V}$	-	35	IG	
Dynamic characteristics						
Turn-on delay time	$t_{d(on)}$	$V_{GS}=10\text{V}$ $V_{DS}=10\text{V}$ $f=1\text{MHz}$	-	943	-	μs
Turn-off delay time	$t_{d(off)}$		-	107	-	
Turn-off delay time	$t_{d(off)}$		-	90	-	
Gate resistance	R_g	$f=1\text{MHz}$	-	22	-	Ω
Switching characteristics						
Switching voltage	V_{sw}	$V_{GS}=10\text{V}$ $V_{DS}=10\text{V}$ $f=1\text{MHz}$	-	8.2	-	μs
Switching voltage	V_{sw}		-	17	-	
Switching voltage	V_{sw}		-	4.15	-	
Switching voltage	V_{sw}		-	6	-	
Switching current	I_{sw}	$V_{GS}=10\text{V}$ $V_{DS}=10\text{V}$ $f=1\text{MHz}$	-	32	-	mA
Switching current	I_{sw}		-	55	-	
Switching current	I_{sw}		-	10	-	
Switching current	I_{sw}		-	60	-	
Drain-Source Diode Characteristics						
Reverse current	I_{RS}	$V_{GS}=0\text{V}$	-	-	-	μA
Reverse current (at $V_{GS}=0\text{V}$)	I_{RS}		-	-	-	μA
Reverse current (at $V_{GS}=0\text{V}$)	I_{RS}		-	-	-	μA

Notes:

1. Limited only by maximum temperature allowed.

2. $P_{W} \leq 10\mu\text{s}$, Duty cycle $\leq 1\%$.

3. EAS condition: $V_{DD}=15\text{V}$, $V_{GS}=10\text{V}$, $L=0.5\text{mH}$, $R_g=25\Omega$ Starting $T_j=25^\circ\text{C}$.

4. EAS condition: $V_{DD}=-15\text{V}$, $V_{GS}=-10\text{V}$, $L=0.5\text{mH}$, $R_g=25\Omega$ Starting $T_j=25^\circ\text{C}$.

5. Pulse Test : Pulse Width $\leq 300\mu\text{s}$, duty cycle $\leq 2\%$.

6. Guaranteed by design, not subject to production.

7. The value of $R_{\theta JA}$ is measured with the device mounted on 1 in² FR-4 board with 1oz. Copper, in a still air environment with $T_a=25^\circ\text{C}$.

Typical Electrical and Thermal Characteristics ($T_j=25\text{ }^\circ\text{C}$)

N-Channel MOS

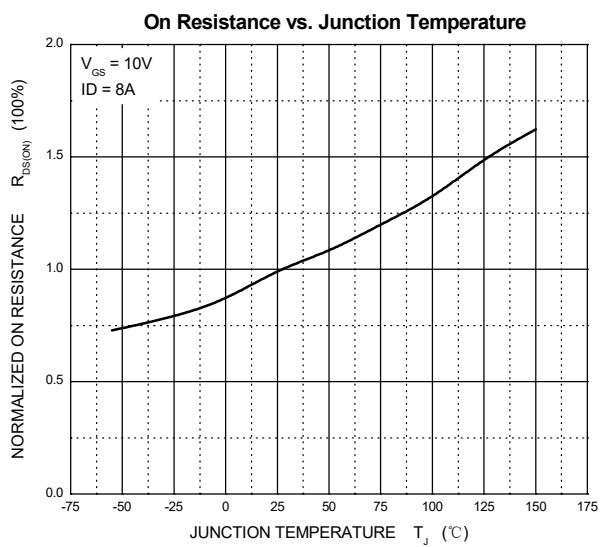
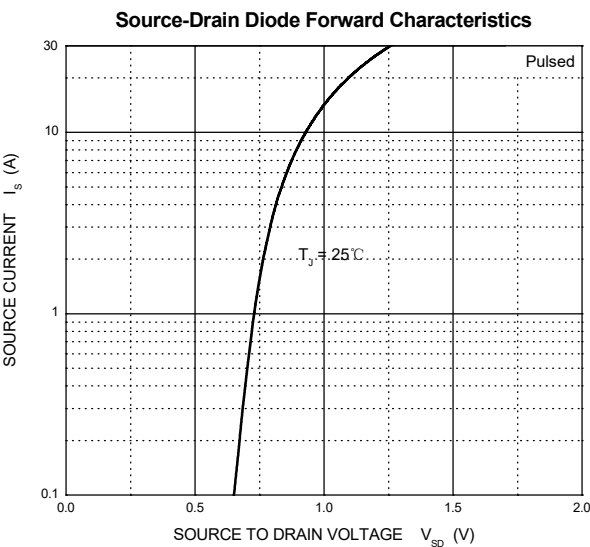
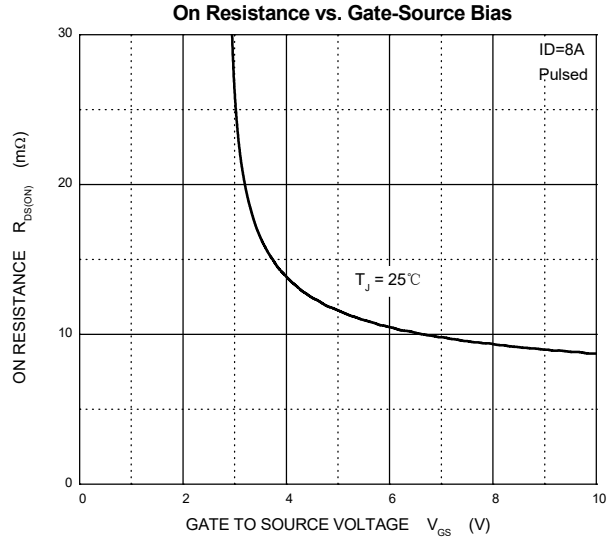
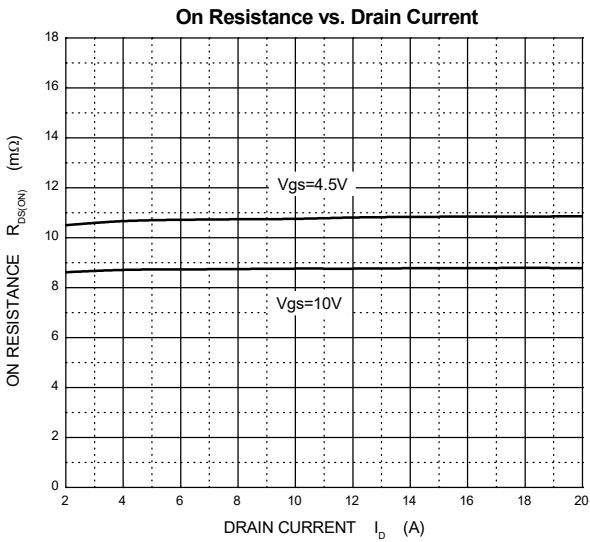
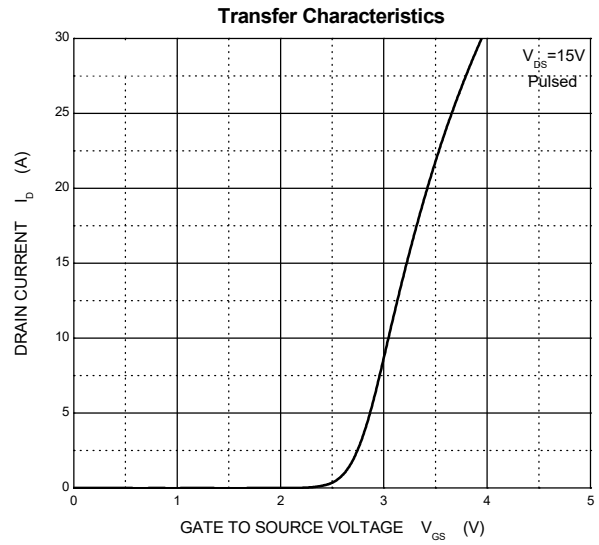
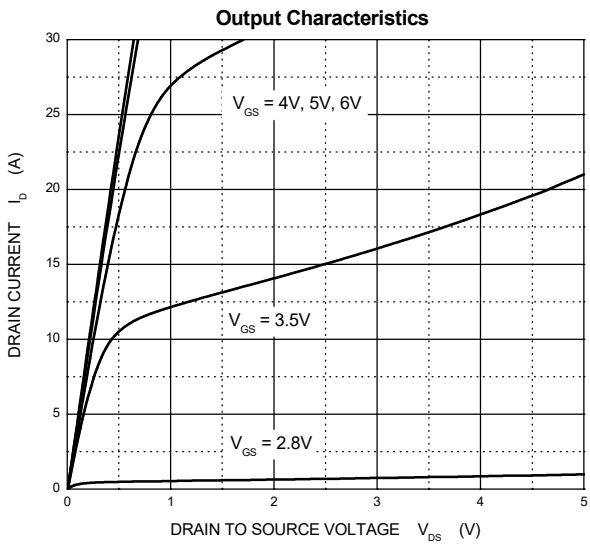

Typical Characteristics ($T_j=25\text{ }^\circ\text{C}$)

N-Channel MOS

Typical Capacitances

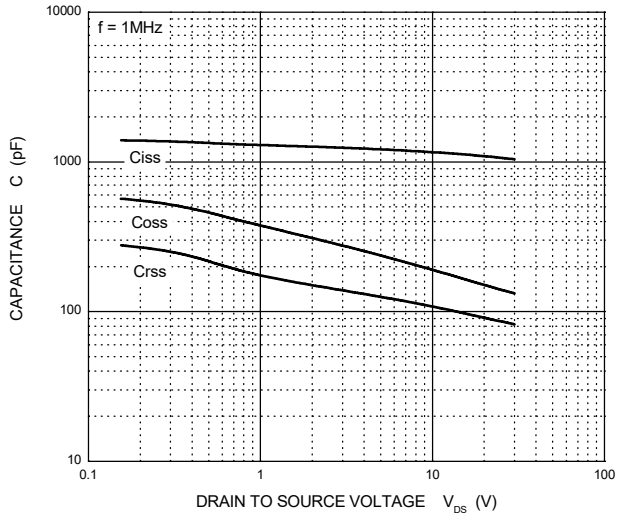

Gate Charge

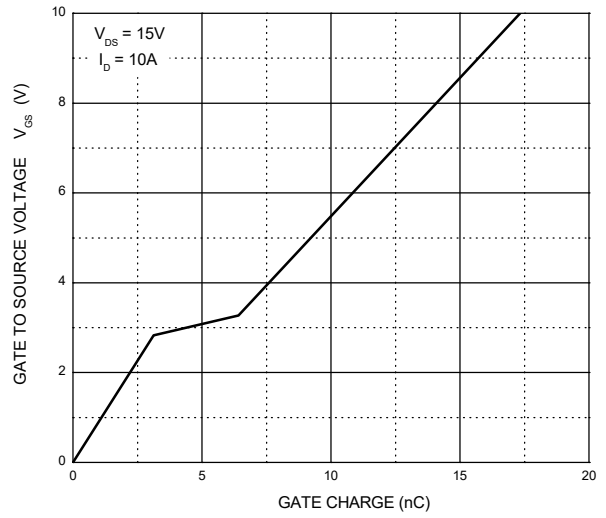

Transient Thermal Impedance, Junction-Case

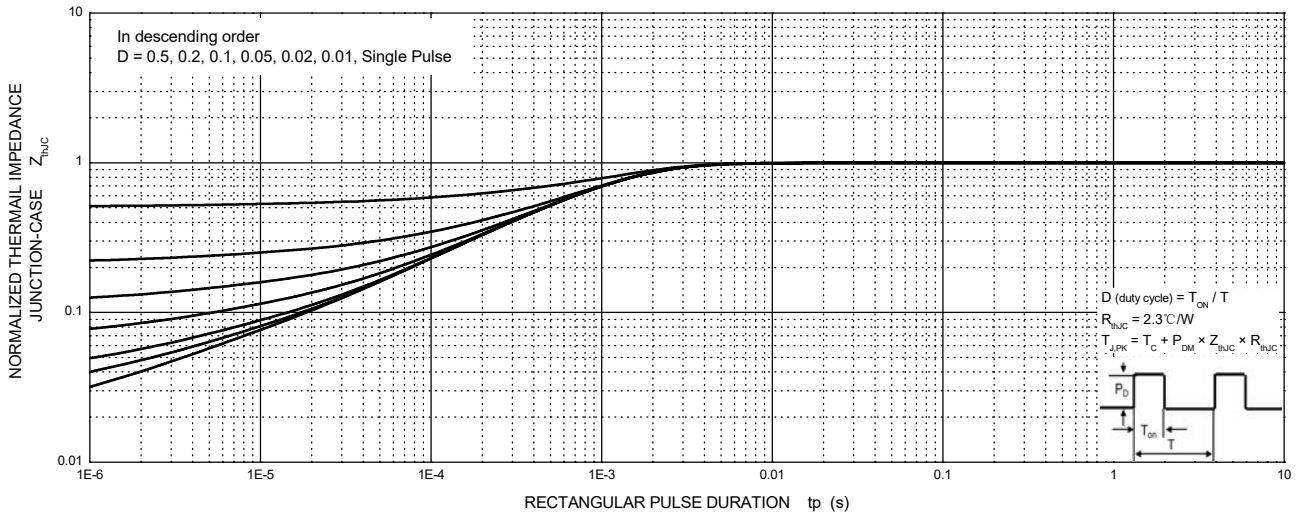

Maximum Safe Operating Area

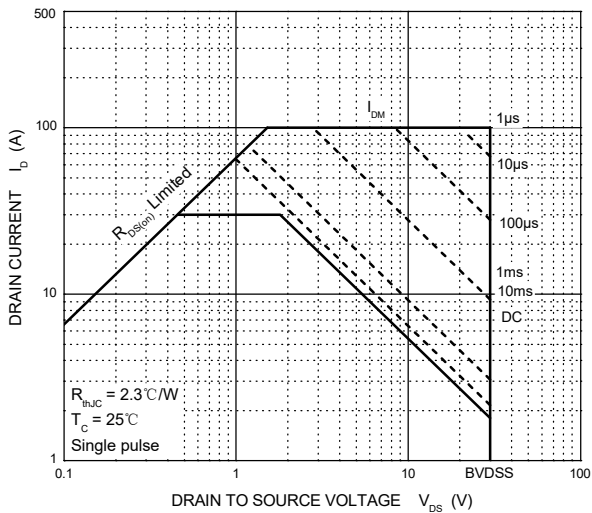

Typical Electrical and Thermal Characteristics ($T_j=25^\circ\text{C}$)

P-Channel MOS

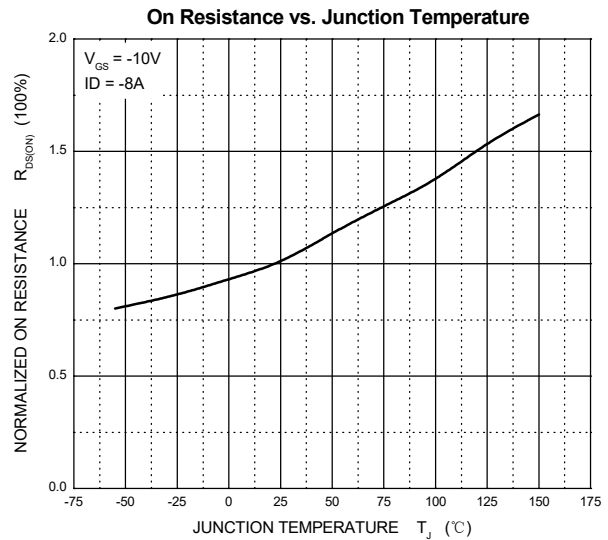
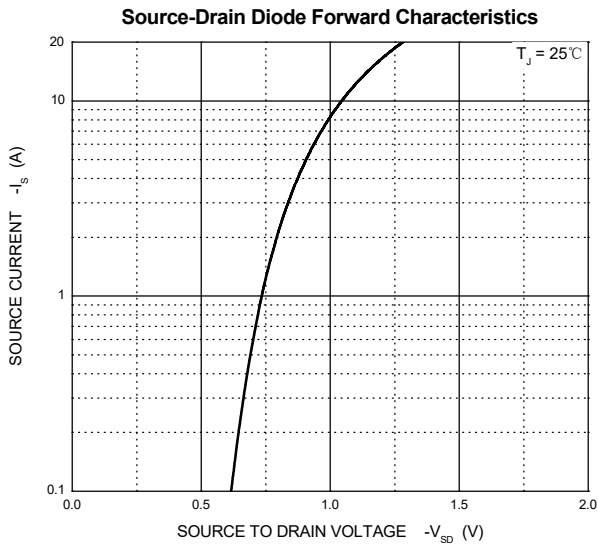
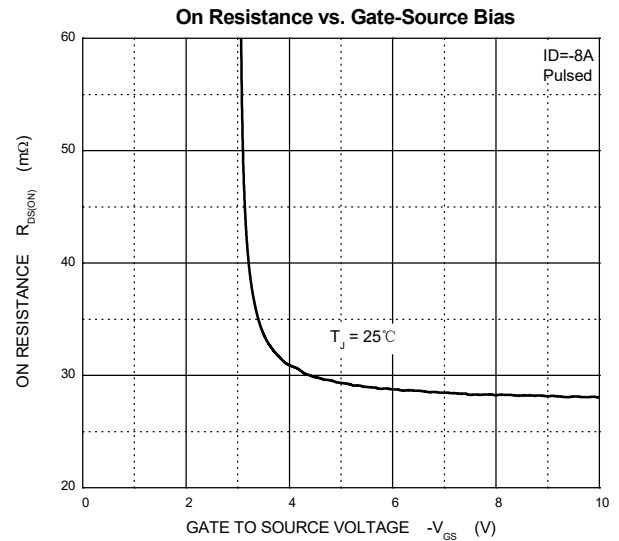
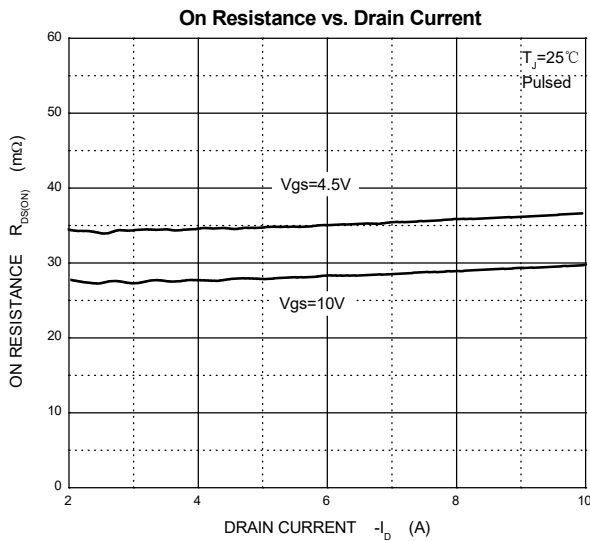
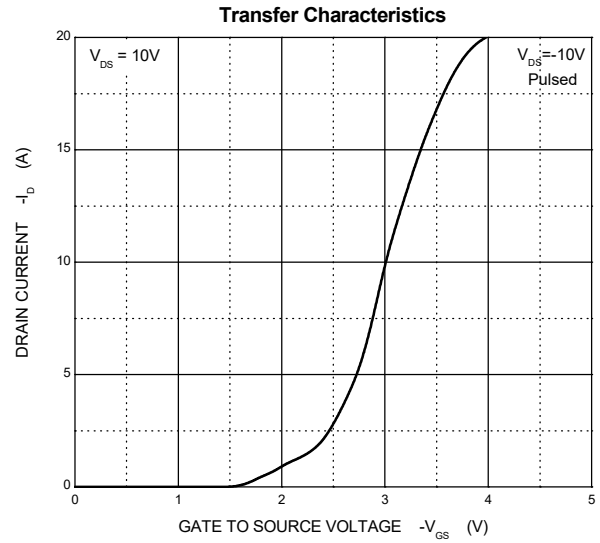
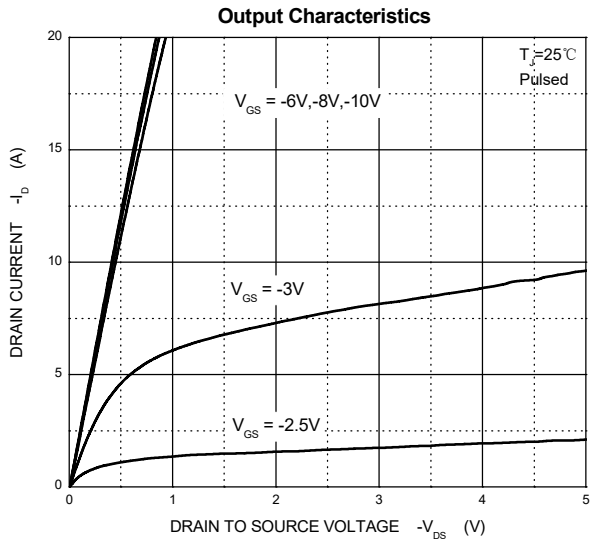

Typical Characteristics ($T_j=25^\circ\text{C}$)

P-Channel MOS

Capacitances

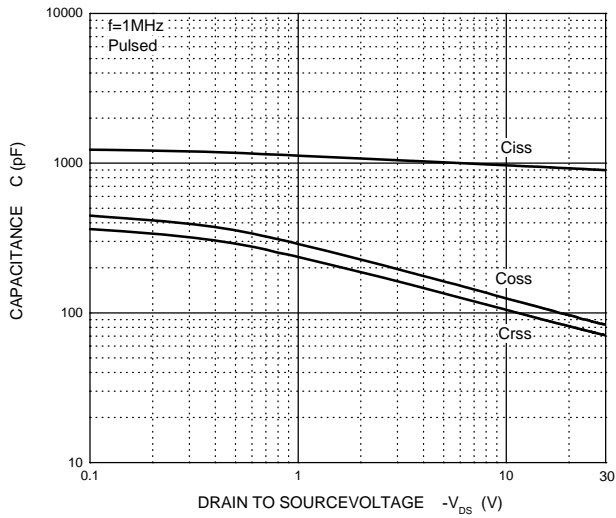

Maximum Safe Operating Area

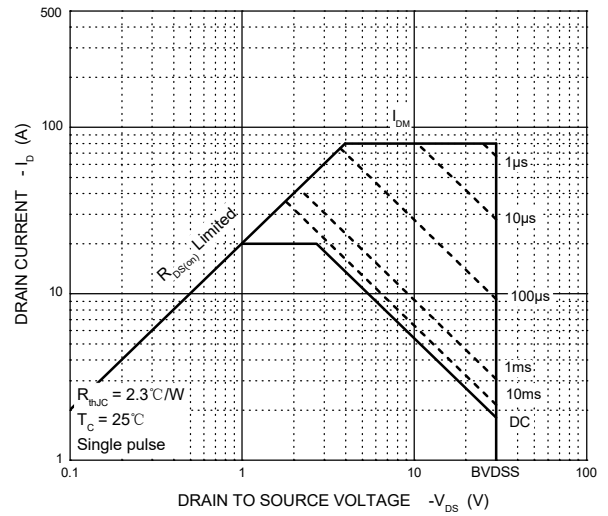

Transient Thermal Impedance, Junction-Case

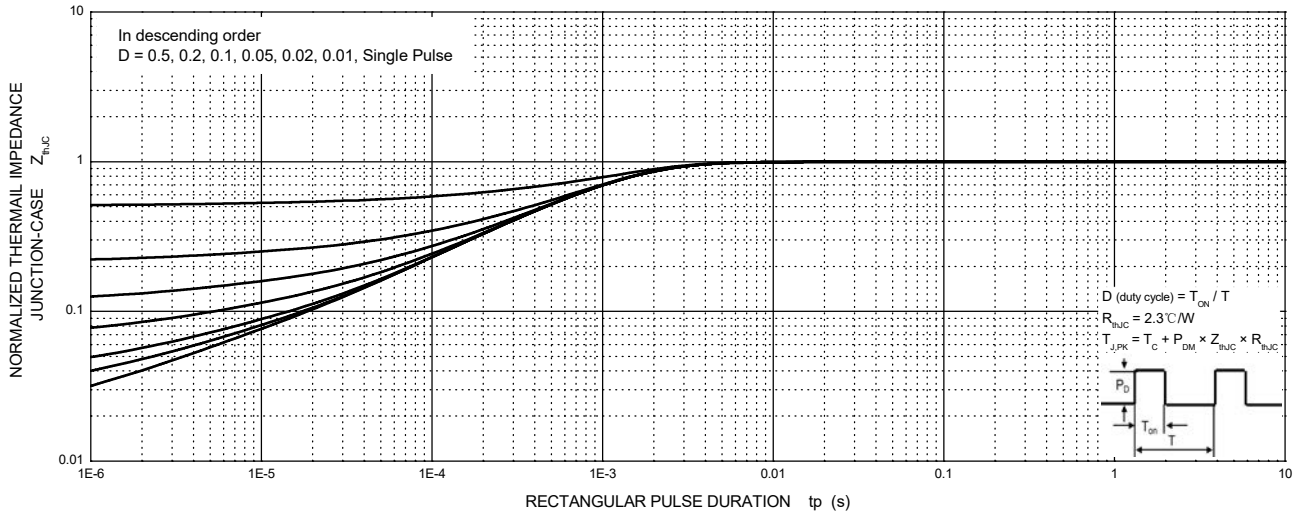

PDFNWB3.3×3.3-8L-B Package Outline Dimensions

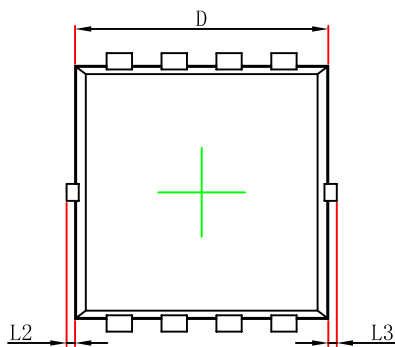

Top View
[顶视图]

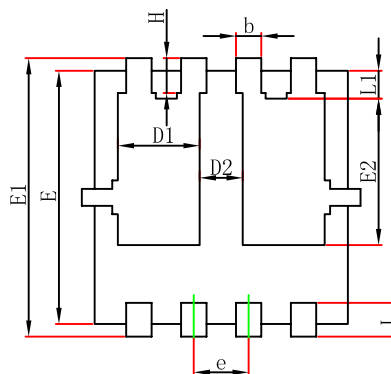

Bottom View
[背视图]

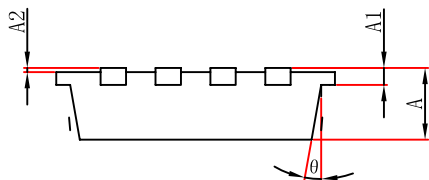

Side View
[侧视图]

Symbol	Dimensions In Millimeters		Dimensions In Inches	
	Min.	Max.	Min.	Max.
A	0.650	0.850	0.026	0.033
A1	0.152 REF.		0.006 REF.	
A2	0~0.05		0~0.002	
D	2.900	3.100	0.114	0.122
D1	0.935	1.135	0.037	0.045
D2	0.280	0.480	0.011	0.019
E	2.900	3.100	0.114	0.122
E1	3.150	3.450	0.124	0.136
E2	1.535	1.935	0.060	0.076
b	0.200	0.400	0.008	0.016
e	0.550	0.750	0.022	0.030
L	0.300	0.500	0.012	0.020
L1	0.180	0.480	0.007	0.019
L2	0~0.100		0~0.004	
L3	0~0.100		0~0.004	
H	0.315	0.515	0.012	0.020
θ	9°	13°	9°	13°

NOTICE

JSCJ reserves the right to make modifications, enhancements, improvements, corrections or other changes without further notice to any product herein. JSCJ does not assume any liability arising out of the application or use of any product described herein.

PDFNWB3.3×3.3-8L-B Tape and Reel

PDFNWB3.3×3.3-8L-B Embossed Carrier Tape

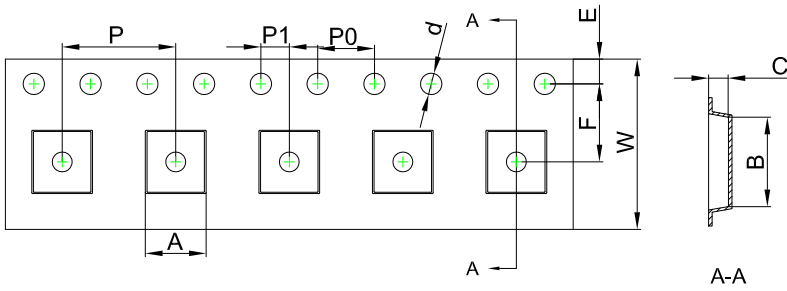

Packaging Description:

PDFNWB3.3×3.3-8L-B parts are shipped in tape. The carrier tape is made from a dissipative (carbon filled) polycarbonate resin. The cover tape is a multilayer film (Heat Activated Adhesive in nature) primarily composed of polyester film, adhesive layer, sealant, and anti-static sprayed agent. These reeled parts in standard option are shipped with 5,000 units per 13" or 33.0 cm diameter reel. The reels are clear in color and is made of polystyrene plastic (anti-static coated).

Dimensions are in millimeter										
Pkg type	A	B	C	d	E	F	P0	P	P1	W
PDFNWB3.3×3.3-8L-B	3.55	3.55	1.10	Ø1.50	1.75	5.50	4.00	8.00	2.00	12.00

PDFNWB3.3×3.3-8L-B Tape Leader and Trailer

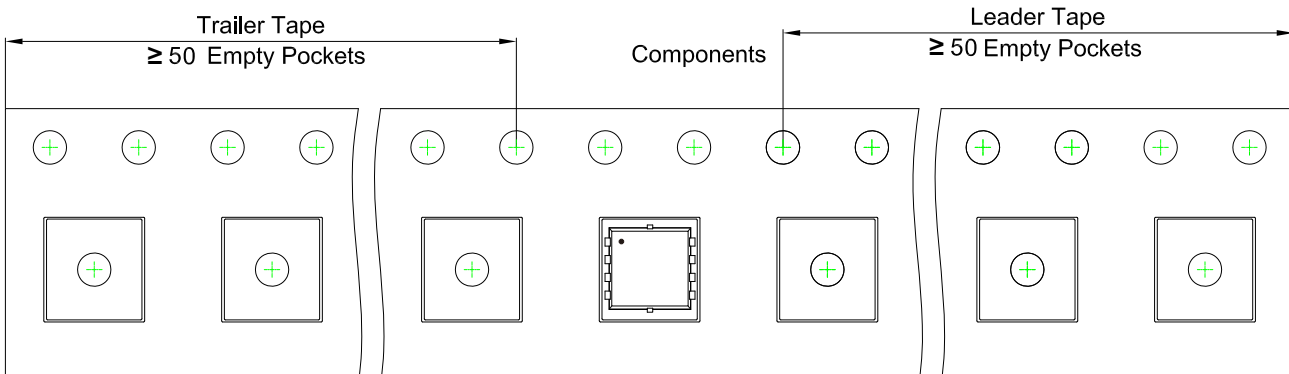

PDFNWB3.3×3.3-8L-B Reel

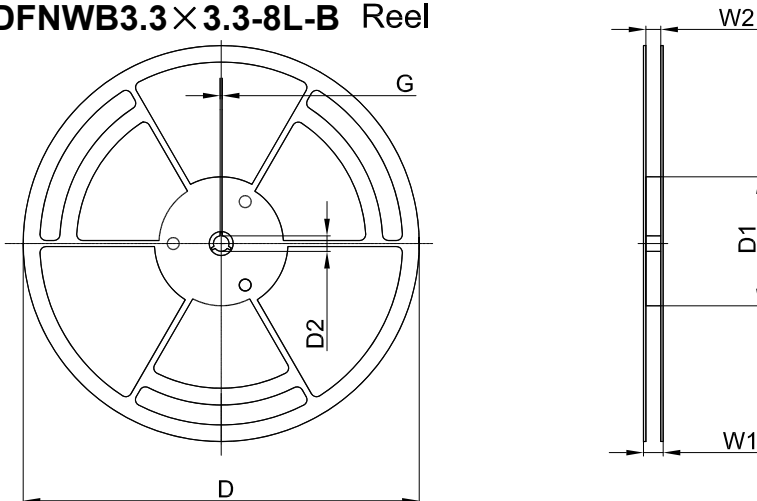

Dimensions are in millimeter						
Reel Option	D	D1	D2	G	W1	W2
13" Dia	Ø330.00	100.00	13.00	1.90	17.60	12.40

REEL	Reel Size	Box	Box Size(mm)	Carton	Carton Size(mm)
5,000 pcs	13 inch	5,000 pcs	340×336×29	50,000 pcs	353×346×365