

MOSFET ELECTRICAL CHARACTERISTICS

$T_a=25\text{ }^\circ\text{C}$ unless otherwise specified

| Parameter | Symbol | Test Condition | Min | Typ | Max | Unit |
|---|---------------|---|-----------------------------------|------|-----------|------------|
| Off characteristics | | | | | | |
| Drain-source breakdown voltage | $V_{(BR)DSS}$ | $V_{GS} = 0V, I_D = 250\mu A$ | 40 | | | V |
| Zero gate voltage drain current | I_{DSS} | $V_{DS} = 32V, V_{GS} = 0V$ | $T_J = 25\text{ }^\circ\text{C}$ | | 1.0 | μA |
| | | | $T_J = 125\text{ }^\circ\text{C}$ | | 100 | |
| Gate-body leakage current | I_{GSS} | $V_{DS} = 0V, V_{GS} = \pm 20V$ | | | ± 100 | nA |
| On characteristics ④ | | | | | | |
| Gate-threshold voltage | $V_{GS(th)}$ | $V_{DS} = V_{GS}, I_D = 250\mu A$ | 1.0 | 1.7 | 2.5 | V |
| Static drain-source on-state resistance | $R_{DS(on)}$ | $V_{GS} = 10V, I_D = 20A$ | | 4.8 | 6.0 | m Ω |
| | | $V_{GS} = 4.5V, I_D = 10A$ | | 6.2 | 8.0 | m Ω |
| Forward transconductance | g_{fs} | $V_{DS} = 10V, I_D = 10A$ | | 15 | | S |
| Dynamic characteristics ④ ⑤ | | | | | | |
| Input capacitance | C_{iss} | $V_{DS} = 25V, V_{GS} = 0V, f = 1MHz$ | | 2540 | 3540 | μF |
| Output capacitance | C_{oss} | | | 218 | 420 | |
| Reverse transfer capacitance | C_{rss} | | | 178 | 247 | |
| Gate resistance | R_g | $f = 1MHz$ | | 1.6 | | Ω |
| Switching characteristics ④ ⑤ | | | | | | |
| Total gate charge | Q_g | $V_{DS} = 32V, V_{GS} = 4.5V, I_D = 10A$ | | 25.2 | 54 | nC |
| Gate-source charge | Q_{gs} | | | 5.3 | 14 | |
| Gate-drain charge | Q_{gd} | | | 12.5 | 23 | |
| Turn-on delay time | $t_{d(on)}$ | $V_{DS} = 20V, I_D = 1A, V_{GS} = 10V, R_G = 3\Omega$ | | 13.7 | 30 | ns |
| Turn-on rise time | t_r | | | 19.2 | 40 | |
| Turn-off delay time | $t_{d(off)}$ | | | 40 | 80 | |
| Turn-off fall time | t_f | | | 13 | 30 | |
| Drain-Source Diode Characteristics | | | | | | |
| Drain-source diode forward voltage | V_{SD} ④ | $V_{GS} = 0V, I_S = 10A$ | | | 1.2 | V |
| Continuous drain-source diode forward current | I_S ① | | | | 65 | A |
| Pulsed drain-source diode forward current | I_{SM} ② | | | | 240 | A |

Notes:

- $T_C = 25\text{ }^\circ\text{C}$ Limited only by maximum temperature allowed.
- $P_W \leq 10\mu s$, Duty cycle $\leq 1\%$.
- EAS condition: $V_{DD} = 20V, V_{GS} = 10V, L = 0.1mH, R_g = 25\Omega$ Starting $T_J = 25\text{ }^\circ\text{C}$.
- Pulse Test : Pulse Width $\leq 300\mu s$, duty cycle $\leq 2\%$.
- Guaranteed by design, not subject to production.
- The value of $R_{\theta JA}, R_{\theta JC}$ is measured with the device mounted on 1 in 2 FR-4 board with 2oz. Copper, in a still air environment with $T_a = 25\text{ }^\circ\text{C}$.

MOSFET ELECTRICAL CHARACTERISTICS

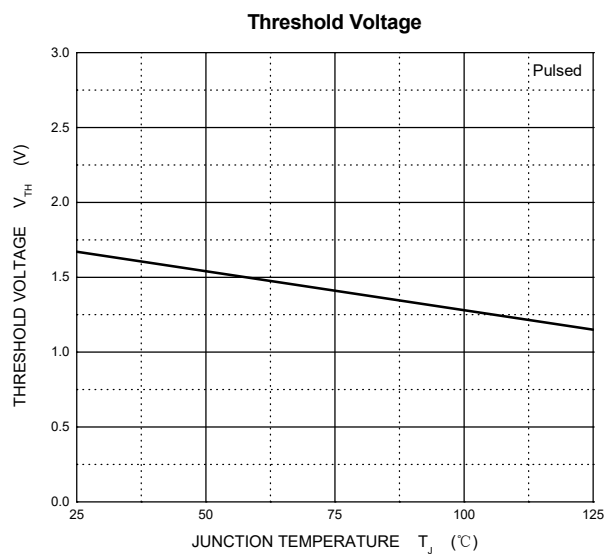
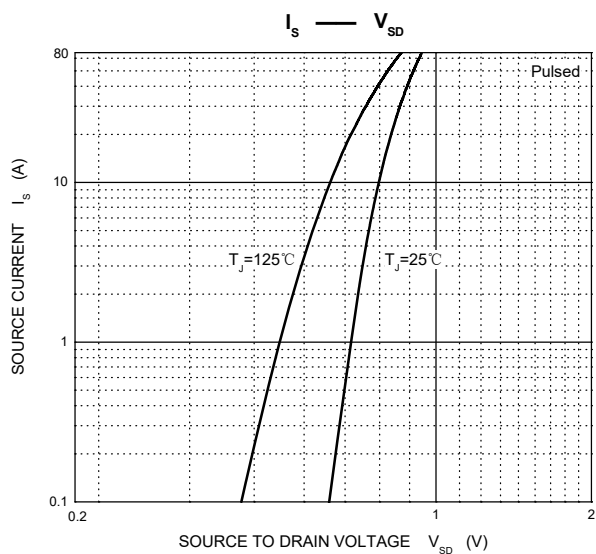
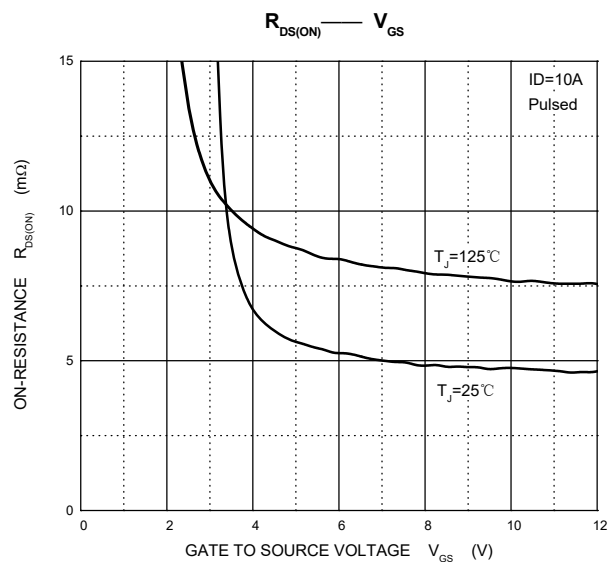
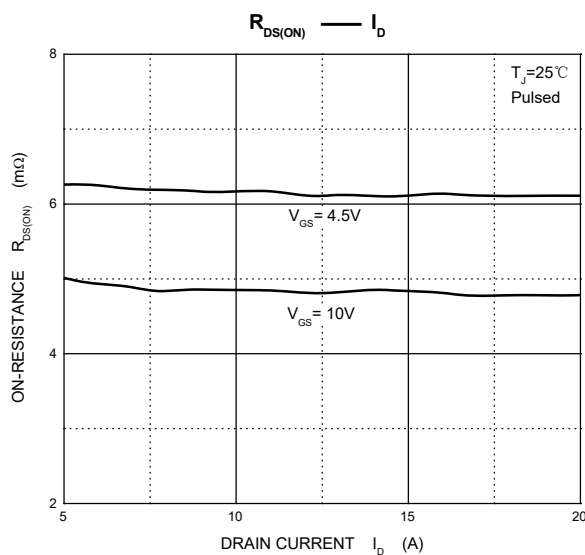
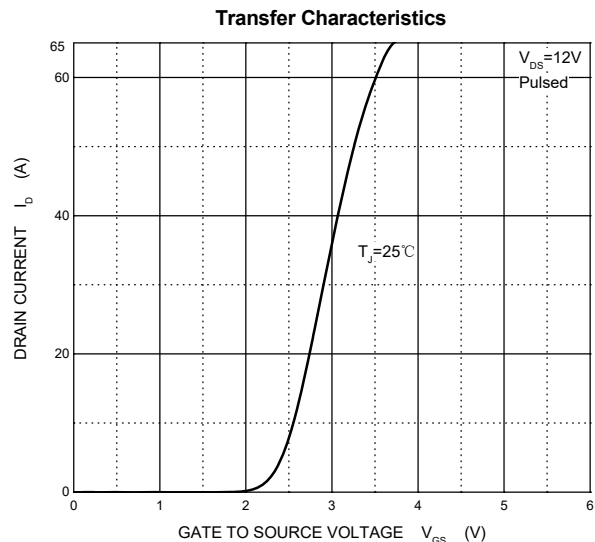
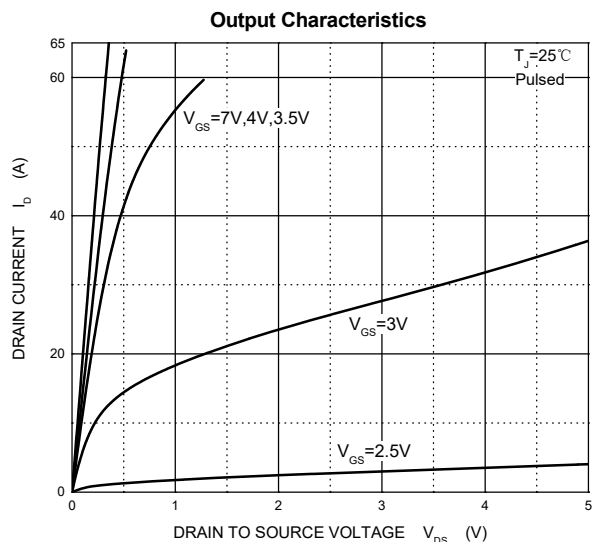

Capacitances

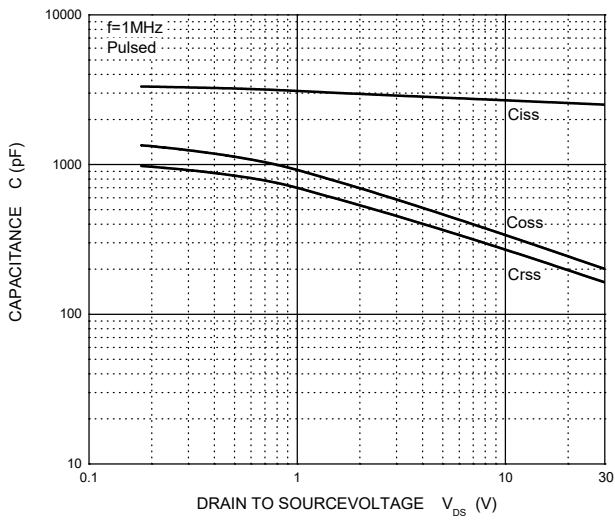

Gate Charge

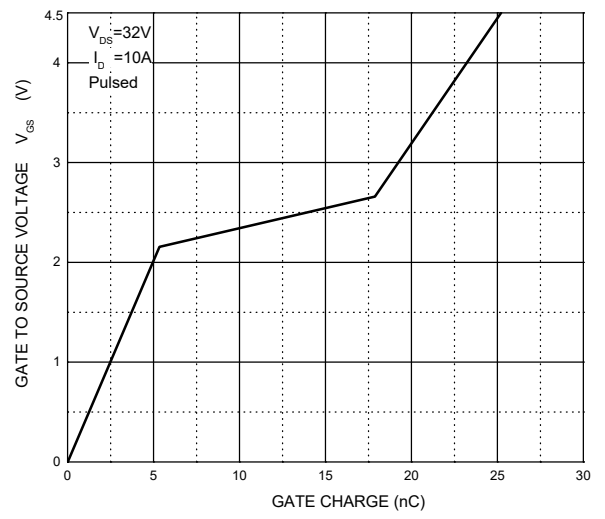

NORMALIZED TRANSIENT THERMAL IMPEDANCE

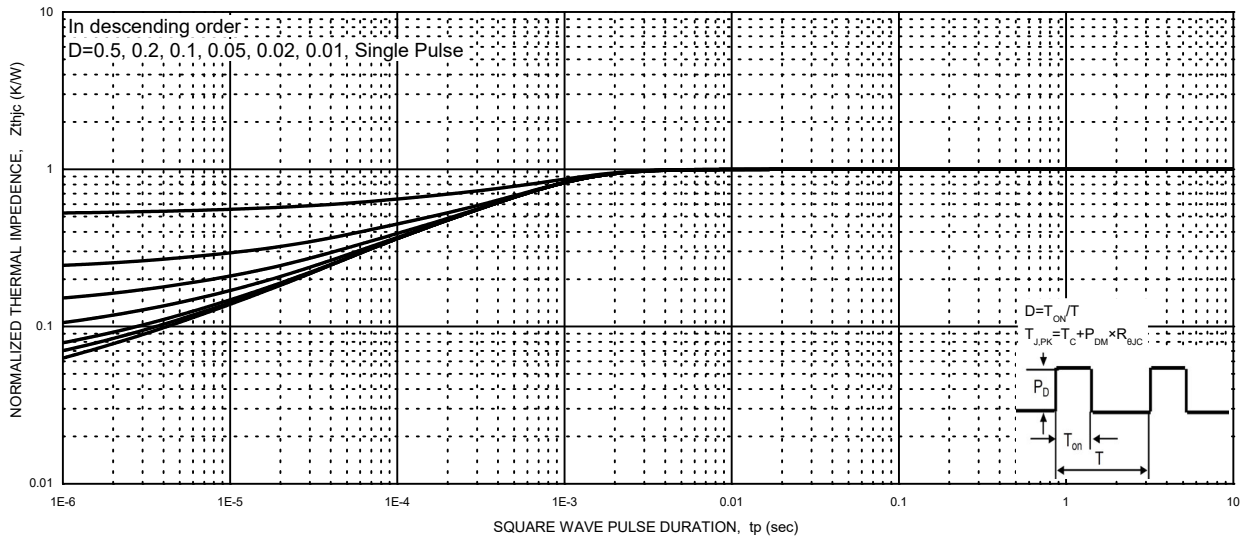

MAXIMUM FORWARD BIASED SAFE OPERATING AREA

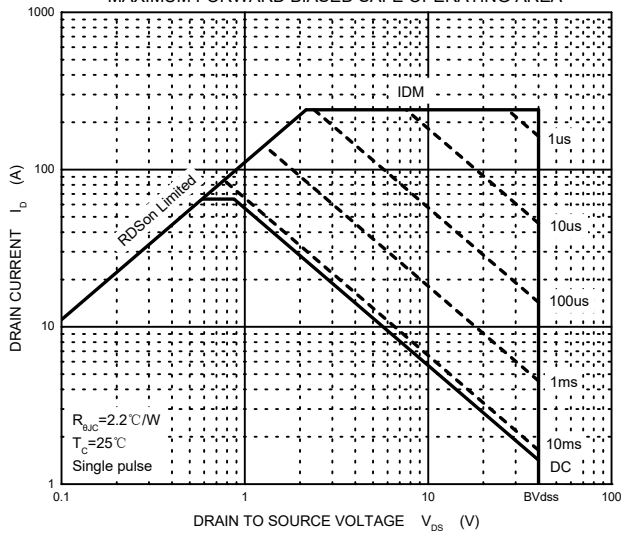

PDFNWB3.3×3.3-8L PACKAGE OUTLINE DIMENSIONS

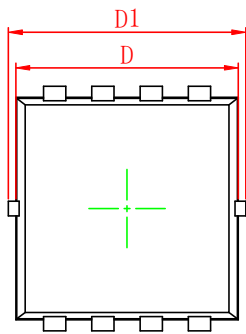

Top View
[顶视图]

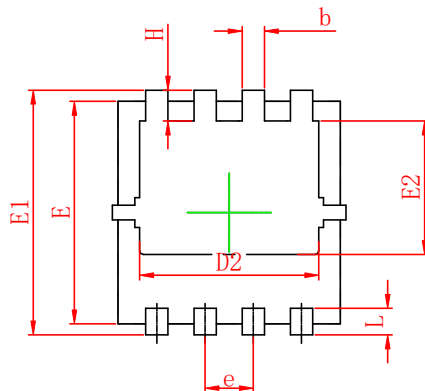

Bottom View
[背视图]

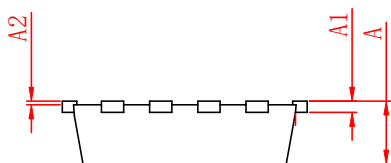

Side View
[侧视图]

| Symbol | Dimensions In Millimeters | | Dimensions In Inches | |
|--------|---------------------------|------|----------------------|-------|
| | Min. | Max. | Min. | Max. |
| A | 0.65 | 0.90 | 0.026 | 0.035 |
| A1 | 0.15 REF. | | 0.006 REF. | |
| A2 | 0~0.05 | | 0~0.002 | |
| D | 2.90 | 3.20 | 0.114 | 0.126 |
| D1 | 3.00 | 3.40 | 0.118 | 0.134 |
| D2 | 2.30 | 2.70 | 0.091 | 0.106 |
| E | 2.90 | 3.20 | 0.114 | 0.126 |
| E1 | 3.00 | 3.40 | 0.118 | 0.134 |
| E2 | 1.60 | 1.90 | 0.063 | 0.075 |
| b | 0.20 | 0.42 | 0.008 | 0.017 |
| e | 0.65 BSC. | | 0.026 BSC. | |
| L | 0.20 | 0.50 | 0.008 | 0.020 |
| H | 0.32 | 0.52 | 0.012 | 0.020 |

Notes:

- 1 Dimensions exclusive of mold gate burrs.
- 2 Dimensions exclusive of mold flash and cutting burrs.

PDFNWB3.3×3.3-8L Suggested Pad Layout

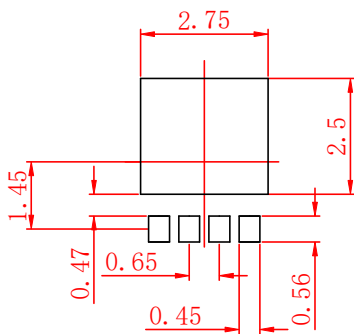

Notes:

- 1 Controlling dimension: in millimeters.
- 2 General tolerance: ±0.05mm.
- 2 The pad layout is for reference purpose only.

NOTICE

JSCJ reserves the right to make modifications, enhancements, improvements, corrections or other changes without further notice to any product herein. JSCJ does not assume any liability arising out of the application or use of any product described herein.

PDFNWB3.3×3.3-8L Tape and Reel

PDFNWB3.3×3.3-8L Embossed Carrier Tape



Packaging Description:

PDFNWB3.3×3.3-8L parts are shipped in tape. The carrier tape is made from a dissipative (carbon filled) polycarbonate resin. The cover tape is a multilayer film (Heat Activated Adhesive in nature) primarily composed of polyester film, adhesive layer, sealant, and anti-static sprayed agent. These reeled parts in standard option are shipped with 5,000 units per 13" or 33.0 cm diameter reel. The reels are clear in color and is made of polystyrene plastic (anti-static coated).

Dimensions are in millimeter

| Pkg type | A | B | C | d | E | F | P0 | P | P1 | W |
|------------------|------|------|------|-------|------|------|------|------|------|-------|
| PDFNWB3.3×3.3-8L | 3.55 | 3.55 | 1.10 | Ø1.50 | 1.75 | 5.50 | 4.00 | 8.00 | 2.00 | 12.00 |

PDFNWB3.3×3.3-8L Tape Leader and Trailer

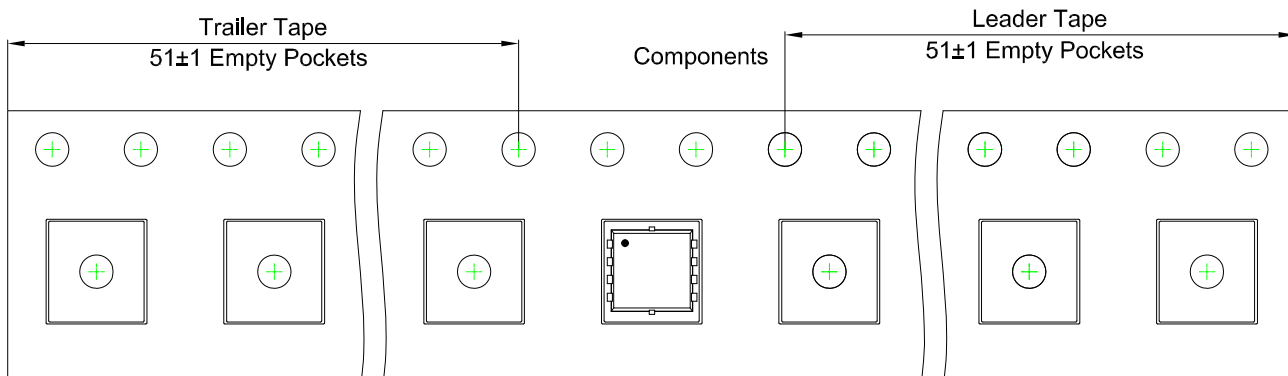

PDFNWB3.3×3.3-8L Reel

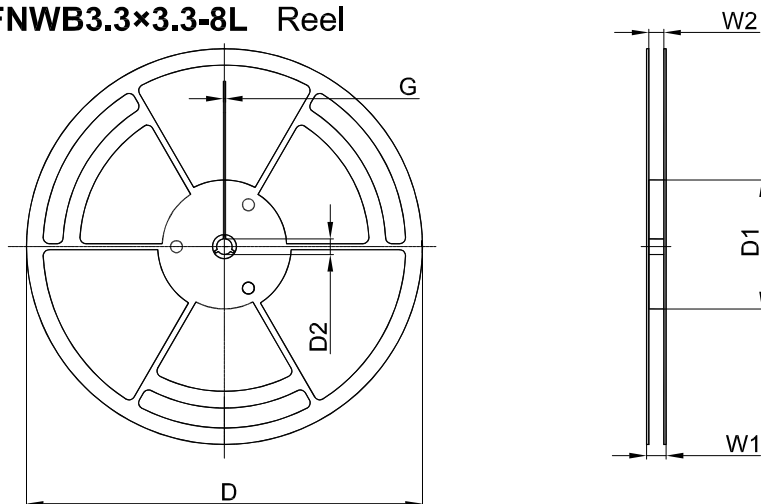

Dimensions are in millimeter

| Reel Option | D | D1 | D2 | G | W1 | W2 |
|-------------|---------|--------|-------|------|-------|-------|
| 13" Dia | φ330.00 | 100.00 | 13.00 | 1.90 | 17.60 | 12.40 |

| Reel | Reel Size | Box | Box Size (mm) | Carton | Carton Size (mm) |
|-----------|-----------|------------|---------------|------------|------------------|
| 5,000 pcs | 13 inch | 10,000 pcs | 360×360×65 | 50,000 pcs | 378×358×382 |