

**PDFNWB5x6-8L Plastic-Encapsulate MOSFET**

**CJAC2R8P02MJ** P-Channel Power MOSFET

**Key Performance Parameters**

$V_{BR(DSS)}$	$R_{DS(on)TYP}$	$I_D$
-20V	2.1mΩ@-4.5V	-150A
	3.0mΩ@-2.5V	

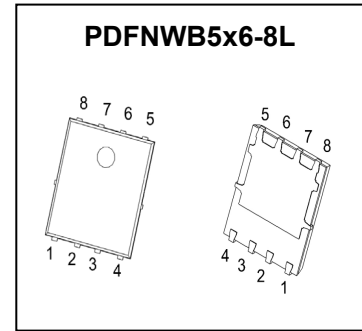

**DESCRIPTION**

The P-Channel enhancement mode power field effect transistors is using advanced trench technology and design to provide excellent RDS(on). It can be used in a wide variety of applications.

**FEATURES**

- Good stability and uniformity with high EAS
- High density cell design for ultra low RDS(ON)

**APPLICATIONS**

- Backlighting
- Power Management Functions
- DC-DC Converters

**MARKING**



XXXXX = 2R8P02MJ  
 Solid dot = Pin1 indicator.  
 YY = Code.

**EQUIVALENT CIRCUIT**

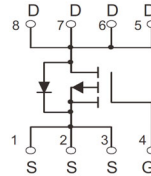

**ABSOLUTE MAXIMUM RATINGS ( T<sub>J</sub>=25°C unless otherwise specified )**

Parameter		Symbol	Value	Unit
Drain-Source Voltage		$V_{DS}$	-20	V
Gate-Source Voltage		$V_{GS}$	±12	V
Continuous Drain Current	T <sub>C</sub> =25°C	$I_D$	-150	A
	T <sub>C</sub> =100°C		-95	
Pulsed Drain Current		$I_{DM}^{①②}$	-600	A
Continuous Drain Current	T <sub>A</sub> =25°C	$I_D$	-22	A
	T <sub>A</sub> =75°C		-17	
Avalanche Current		$I_{AS}^{③}$	-26	A
Single Pulsed Avalanche Energy		$E_{AS}^{③}$	169	mJ
Power Dissipation		$P_D^{①}$	179	W
Operating Junction and Storage Temperature Range		T <sub>J</sub> , T <sub>stg</sub>	-55~+150	°C

**Thermal Characteristics**

Parameter	Symbol	Value		Unit
		Typ	Max	
Thermal Resistance from Junction to Case	$R_{θJC}$	0.45	0.70	°C/W
Thermal Resistance from Junction to Ambient	$R_{θJA}^{⑥}$	41	62.5	°C/W

# Typical Characteristics

## ELECTRICAL CHARACTERISTICS ( $T_J=25^{\circ}\text{C}$ unless otherwise specified)

### Static Characteristics

Parameter	Symbol	Test Condition	Value			Unit	
			Min	Typ	Max		
Drain-source breakdown voltage	$V_{(BR)DSS}$	$V_{GS}=0V, I_D=-250\mu A$	-20	-	-	V	
Zero gate voltage drain current	$I_{DSS}$	$V_{DS}=-20V, V_{GS}=0V$	$T_J=25^{\circ}\text{C}$	-	-	-1.0	$\mu A$
			$T_J=125^{\circ}\text{C}$	-	-	-100	
Gate-body leakage current	$I_{GSS}$	$V_{GS}=\pm 12V, V_{DS}=0V$	-	-	$\pm 100$	nA	
Gate-threshold voltage	$V_{GS(th)}$	$V_{DS}=V_{GS}, I_D=-250\mu A$	-0.55	-0.75	-1.0	V	
Static drain-source on-state resistance	$R_{DS(on)}^{(4)}$	$V_{GS}=-4.5V, I_D=-20A$	$T_J=25^{\circ}\text{C}$	-	2.1	2.8	m $\Omega$
			$T_J=125^{\circ}\text{C}$	-	2.8	3.8	
		$V_{GS}=-2.5V, I_D=-20A$	-	3.0	3.9		
Forward transconductance	$g_{FS}$	$V_{DS}=-5V, I_D=-20A$	-	140	-	S	

### Dynamic Characteristics<sup>(5)</sup>

Input capacitance	$C_{iss}$	$V_{GS}=0V, V_{DS}=-10V,$ $f=1\text{MHz}$	-	10608	-	pF
Output capacitance	$C_{oss}$		-	1463	-	
Reverse transfer capacitance	$C_{rss}$		-	1233	-	
Gate resistance	$R_g$	$f=1\text{MHz}$	-	3.4	-	$\Omega$
Total gate charge	$Q_g$	$V_{GS}=-2.5V, V_{DS}=-10V, I_D=-20A$	-	60	-	nC
Total gate charge	$Q_g$	$V_{GS}=-4.5V, V_{DS}=-10V, I_D=-20A$	-	102	-	
Gate charge at threshold	$Q_{G(th)}$		-	8.4	-	
Gate-source charge	$Q_{gs}$		-	15	-	
Gate-drain charge	$Q_{gd}$		-	27	-	
Turn-on delay time	$t_{d(on)}$	$V_{DD}=-10V, V_{GS}=-4.5V,$ $I_D=-20A, R_g=3\Omega$	-	11	-	ns
Turn-on rise time	$t_r$		-	9	-	
Turn-off delay time	$t_{d(off)}$		-	144	-	
Turn-off fall time	$t_f$		-	65	-	

### Reverse Diode Characteristics

Drain-source diode forward voltage	$V_{SD}^{(4)}$	$V_{GS}=0V, I_S=-20A$	-	-	-1.2	V
Continuous drain-source diode forward current	$I_S^{(1)}$		-	-	-150	A
Pulsed drain-source diode forward current	$I_{SM}^{(1)(2)}$		-	-	-600	A
Reverse recovery time	$t_{rr}$	$V_{DD}=-10V, I_S=-20A,$	-	33.8	-	ns
Reverse recovery charge	$Q_{rr}$	$di/dt=-100A/\mu s$	-	28.8	-	nC

Notes:

- ①.  $T_C=25^{\circ}\text{C}$  Limited only by maximum temperature allowed.
- ②.  $P_W \leq 10\mu s$ , Duty cycle  $\leq 1\%$ .
- ③. EAS condition:  $V_{DD}=-18V, V_{GS}=-10V, L=0.5\text{mH}, R_g=25\Omega$  Starting  $T_J=25^{\circ}\text{C}$ .
- ④. Pulse Test : Pulse Width  $\leq 380\mu s$ , duty cycle  $\leq 2\%$ .
- ⑤. Guaranteed by design, not subject to production.
- ⑥. Device mounted on 1 in<sup>2</sup> FR-4 board with 2oz. double-sided Copper, in a still air environment with  $T_A=25^{\circ}\text{C}$ .

# Typical Characteristics

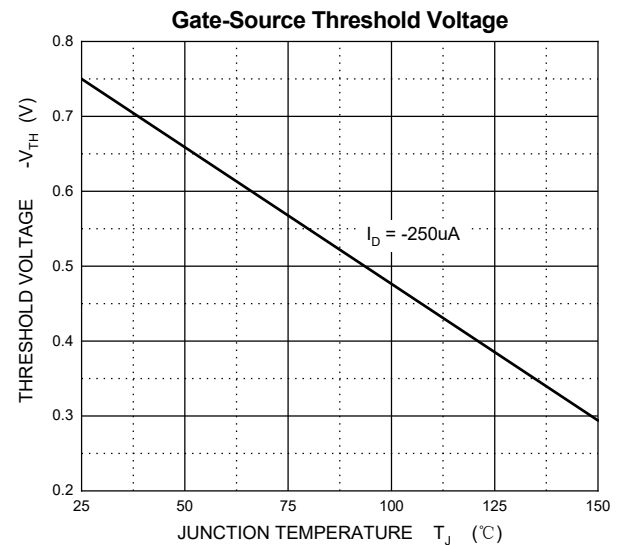
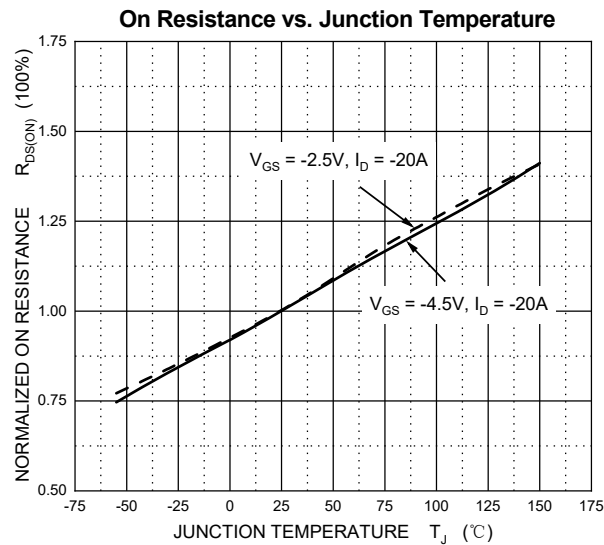
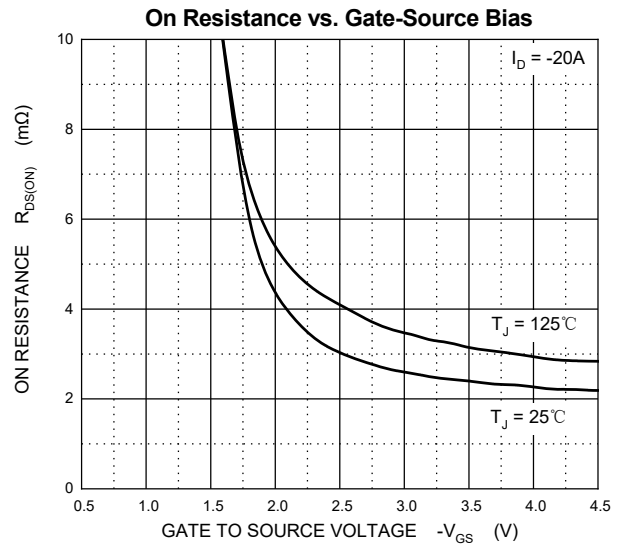
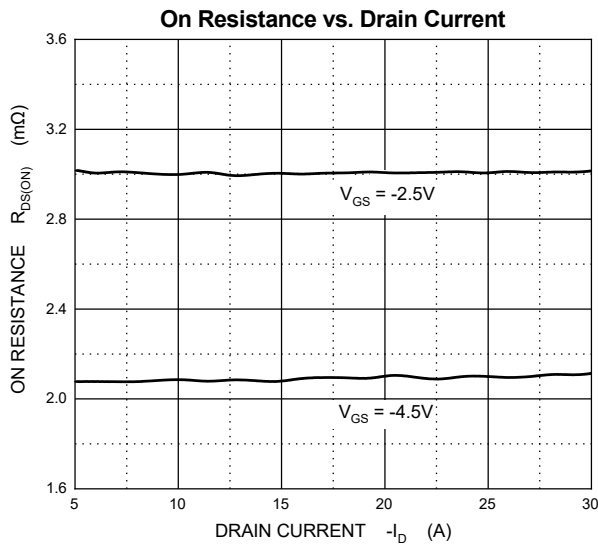
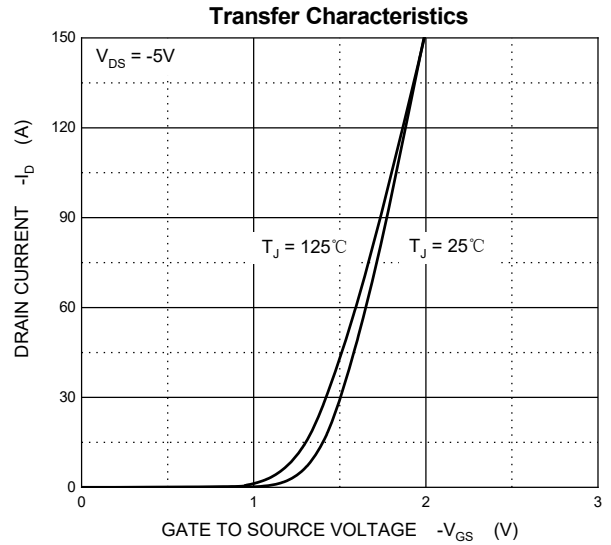
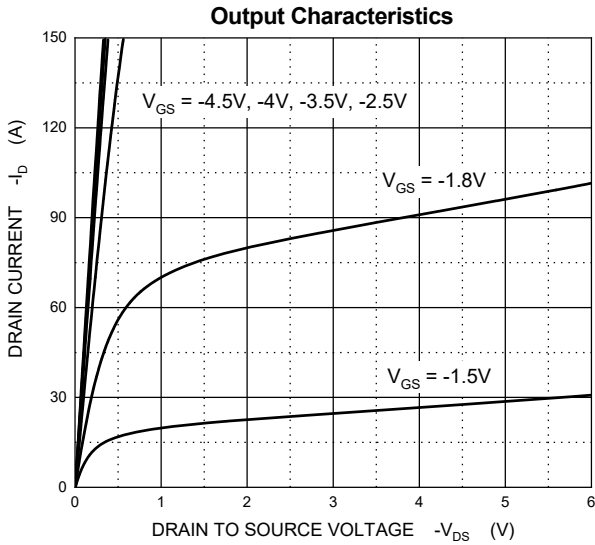

# Typical Characteristics

**Typical Capacitances**

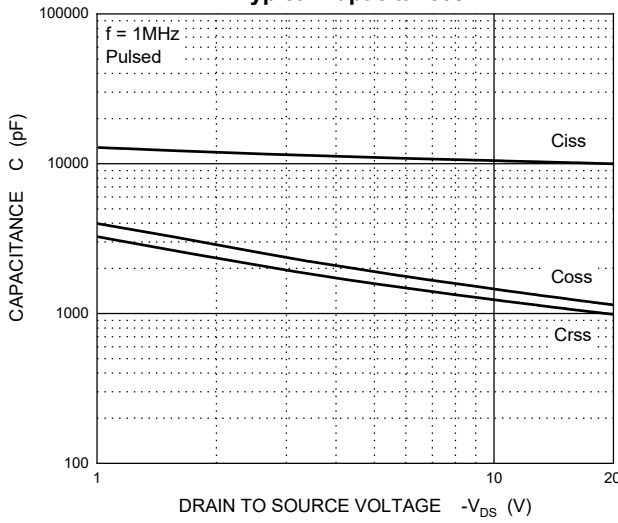

**Gate Charge**

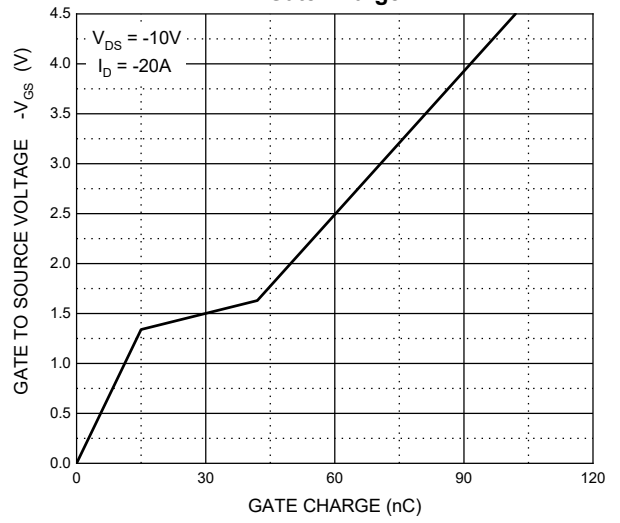

**Source-Drain Diode Forward Characteristics**

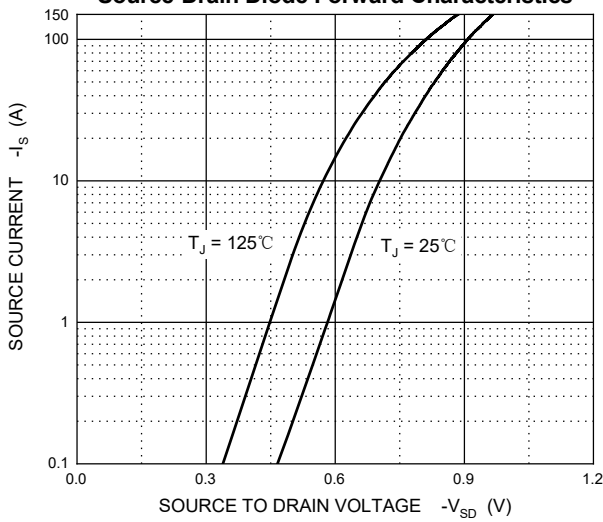

**Drain-Source Breakdown Voltage**

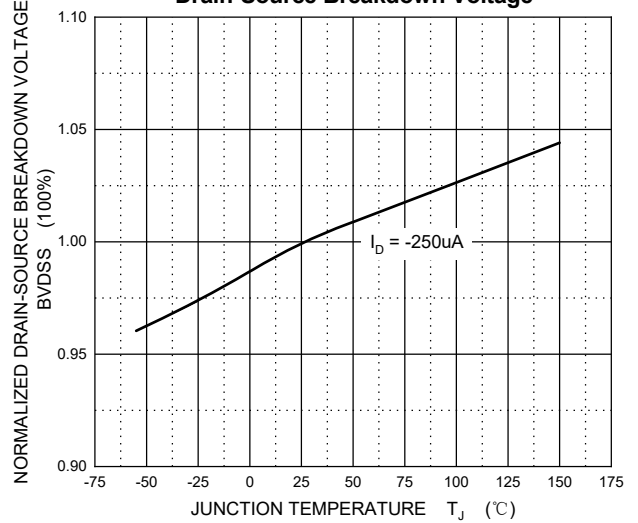

**Maximum Safe Operating Area**

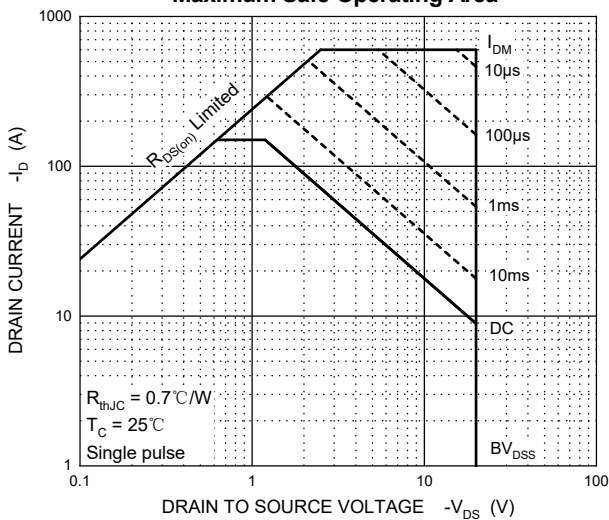

**Transient Thermal Impedance, Junction-Case**

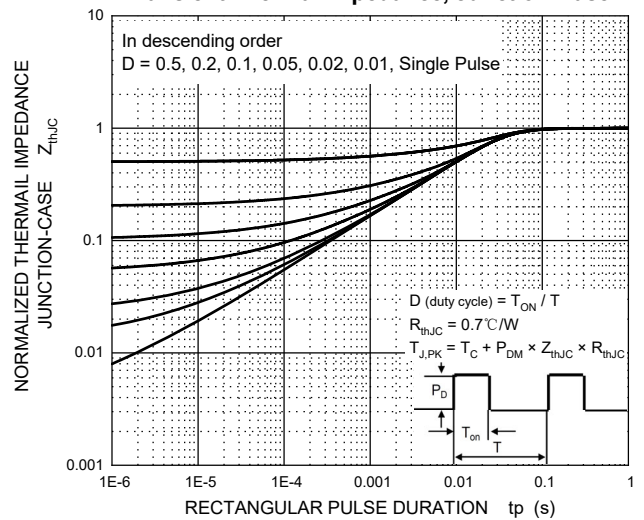

# TEST CIRCUIT AND WAVEFORMS

## Gate Charge



## Resistive Load Switching Time

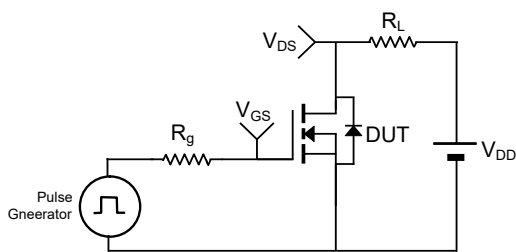

## Un-clamped Inductive Load Switching

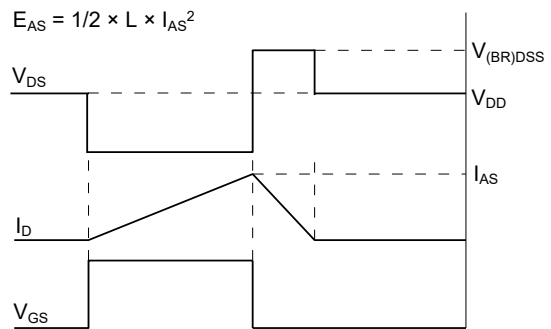
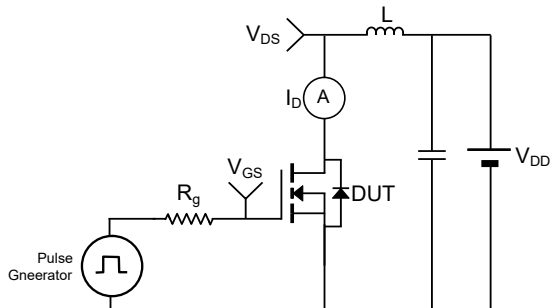

## Drain-Source Body Diode Reverse Recovery

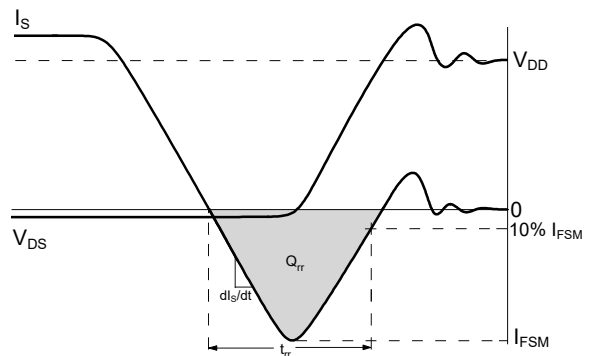
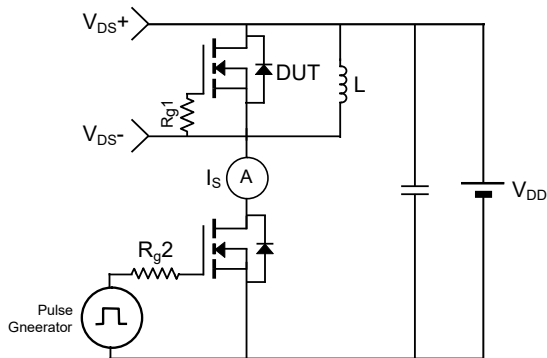

# PDFNWB5×6-8L PACKAGE OUTLINE DIMENSIONS

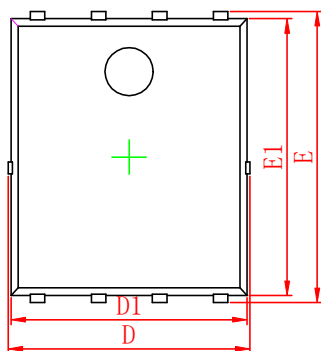

Top View  
[顶视图]

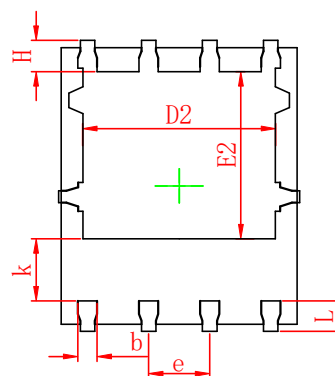

Bottom View  
[背视图]

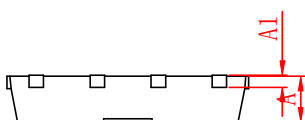

Side View  
[侧视图]

Symbol	Dimensions In Millimeters		Dimensions In Inches	
	Min.	Max.	Min.	Max.
A	0.90	1.10	0.035	0.043
A1	0.25 REF.		0.010 REF.	
D	4.90	5.10	0.193	0.201
D1	4.80	5.00	0.189	0.197
D2	3.90	4.10	0.154	0.161
E	5.90	6.10	0.232	0.240
E1	5.65	5.85	0.222	0.230
E2	3.35	3.65	0.132	0.144
k	1.20	1.50	0.047	0.059
b	0.20	0.45	0.008	0.018
e	1.27 BSC		0.050 BSC	
L	0.55	0.75	0.022	0.030
H	0.45	0.75	0.018	0.030

## Notes:

- 1 Dimensions exclusive of mold gate burrs.
- 2 Dimensions exclusive of mold flash and cutting burrs.

## PDFNWB5×6-8L Suggested Pad Layout

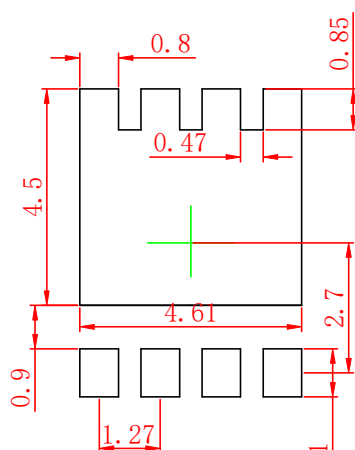

## Notes:

- 1 Controlling dimension: in millimeters.
- 2 General tolerance:  $\pm 0.05$  mm.
- 3 The pad layout is for reference purpose only.

## NOTICE

JSCJ reserves the right to make modifications, enhancements, improvements, corrections or other changes without further notice to any product herein. JSCJ does not assume any liability arising out of the application or use of any product described herein.

# PDFNWB5×6 Tape and Reel

## PDFNWB5×6-8L Embossed Carrier Tape

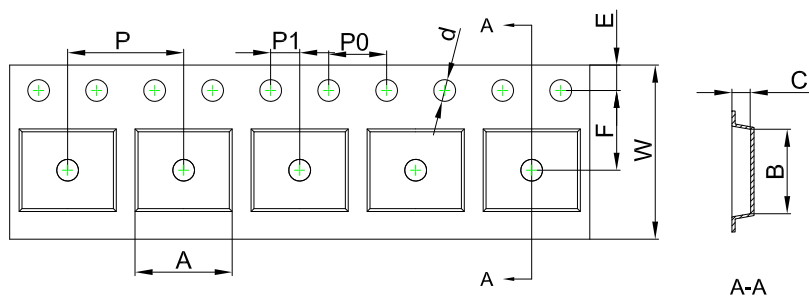

**Packaging Description:**  
**PDFNWB5×6-8L** parts are shipped in tape. The carrier tape is made from a dissipative (carbon filled) polycarbonate resin. The cover tape is a multilayer film (Heat Activated Adhesive in nature) primarily composed of polyester film, adhesive layer, sealant, and anti-static sprayed agent. These reeled parts in standard option are shipped with 5,000 units per 13" or 33.0 cm diameter reel. The reels are clear in color and is made of polystyrene plastic (anti-static coated).

Dimensions are in millimeter										
Pkg type	A	B	C	d	E	F	P0	P	P1	W
PDFNWB5×6-8L	6.30	5.30	1.10	Ø1.50	1.75	5.50	4.00	8.00	2.00	12.00

## PDFNWB5×6-8L Tape Leader and Trailer

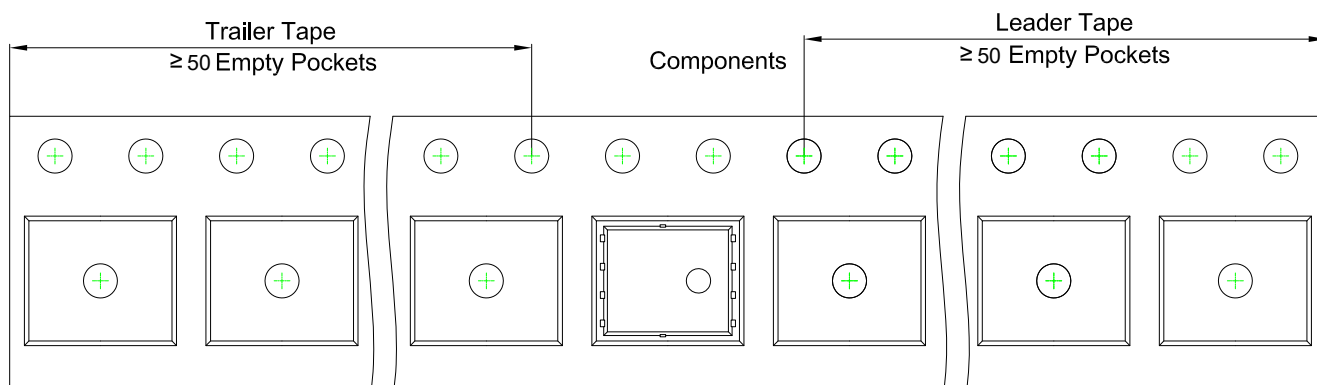

## PDFNWB5×6-8L Reel

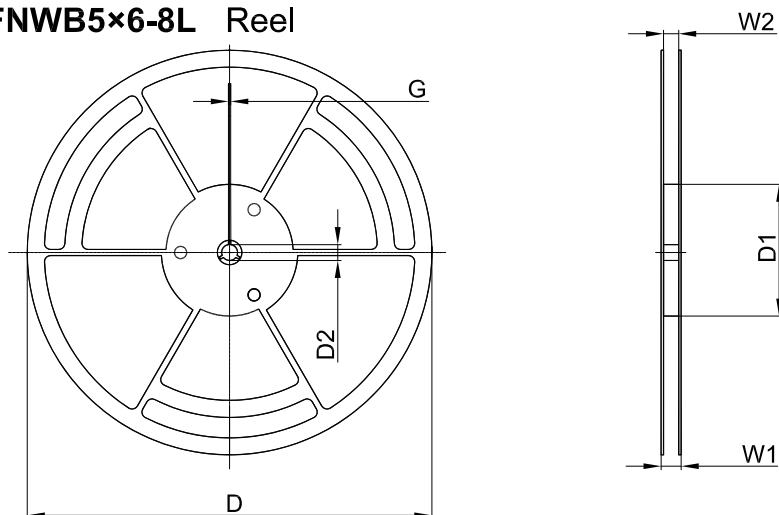

Dimensions are in millimeter						
Reel Option	D	D1	D2	G	W1	W2
13"Dia	Ø330.00	100.00	13.00	1.90	17.60	12.40

REEL	Reel Size	Box	Box Size(mm)	Carton	Carton Size(mm)
5,000 pcs	13 inch	5,000 pcs	340×336×29	50,000 pcs	353×346×365