



TO-263-2L Plastic-Encapsulate MOSFETS

CJB120SN08H N-Channel Power MOSFET

V_{(BR)DSS}	R_{DS(on)TYP}	I_D
85V	5.1mΩ@10V	120A

TO-263-2L

1. GATE
2. DRAIN
3. SOURCE

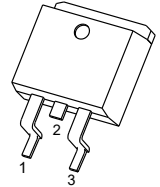

DESCRIPTION

The CJB120SN08H uses shielded gate trench technology and design to provide excellent R_{DS(ON)} with low gate charge. It can be used in a wide variety of applications.

FEATURES

- Low R_{DS(on)}
- Low Gate Charge

APPLICATIONS

- High efficiency power supply
- Secondary synchronous rectifier

MARKING

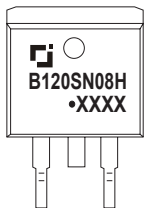

B120SN08H = Device code.
 Solid dot = Green molding compound device,
 if none, the normal device.
 XXXX = Code.

EQUIVALENT CIRCUIT

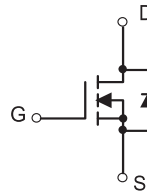

MAXIMUM RATINGS (T_J=25°C unless otherwise noted)

Parameter	Symbol	Limit	Unit
Drain-Source Voltage	V _{DS}	85	V
Gate-Source Voltage	V _{GS}	±20	V
Continuous Drain Current	I _D ^①	120	A
Pulsed Drain Current	I _{DM} ^{①②}	480	A
Single Pulsed Avalanche Energy	E _{AS} ^③	420	mJ
Power Dissipation	P _D ^①	227	W
Thermal Resistance from Junction to Ambient	R _{θJA} ^⑤	62.5	°C/W
Thermal Resistance from Junction to Case	R _{θJC} ^①	0.55	°C/W
Operating Junction and Storage Temperature Range	T _J , T _{stg}	-55~+150	°C

MOSFET ELECTRICAL CHARACTERISTICS

$T_J=25^{\circ}\text{C}$ unless otherwise specified

Parameter	Symbol	Test Condition	Min	Typ	Max	Unit	
Off characteristics							
Drain-source breakdown voltage	$V_{(BR)DSS}$	$V_{GS} = 0V, I_D = 1mA$	85	-	-	V	
Zero gate voltage drain current	I_{DSS}	$V_{DS} = 80V, V_{GS} = 0V$	$T_J = 25^{\circ}\text{C}$	-	-	1.0	μA
			$T_J = 125^{\circ}\text{C}$	-	-	100	
Gate-body leakage current	I_{GSS}	$V_{DS} = 0V, V_{GS} = \pm 20V$	-	-	± 100	nA	
On characteristics ^④							
Gate-threshold voltage	$V_{GS(th)}$	$V_{DS} = V_{GS}, I_D = 250\mu\text{A}$	2	2.8	4	V	
Static drain-source on-state resistance	$R_{DS(on)}$	$V_{GS} = 10V, I_D = 50A$		5.1	6.1	m Ω	
Dynamic characteristics							
Input capacitance	C_{iss}	$V_{DS} = 40V, V_{GS} = 0V, f = 100\text{kHz}$	-	2453	-	μF	
Output capacitance	C_{oss}		-	597	-		
Reverse transfer capacitance	C_{rss}		-	10	-		
Gate resistance	R_g	$f = 1\text{MHz}$	-	3	-	Ω	
Switching characteristics							
Total gate charge	Q_g	$V_{GS} = 4.5V, V_{DS} = 40V, I_D = 50A$	-	19.5	-	nC	
Total gate charge	Q_g	$V_{GS} = 10V, V_{DS} = 40V, I_D = 50A$	-	38.6	-		
Gate-source charge	Q_{gs}		-	9.1	-		
Gate-drain charge	Q_{gd}		-	9.2	-		
Turn-on delay time	$t_{d(on)}$	$V_{DS} = 40V, V_{GS} = 10V, R_L = 2.63\Omega, R_g = 10\Omega$	-	54	-	ns	
Turn-on rise time	t_r		-	54	-		
Turn-off delay time	$t_{d(off)}$		-	228	-		
Turn-off fall time	t_f		-	108	-		
Drain-Source Diode Characteristics							
Drain-source diode forward voltage	V_{SD} ^④	$V_{GS} = 0V, I_S = 20A$	-	-	1.4	V	
Continuous drain-source diode forward current	I_S ^①		-	-	120	A	
Pulsed drain-source diode forward current	I_{SM} ^{①②}		-	-	480	A	
Reverse recovery time	t_{rr}	$di_S/dt = 500A/\mu\text{s}, I_S = 20A, V_{DD} = 30V$	-	74	-	ns	
Reverse recovery charge	Q_{rr}		-	380	-	nC	

Notes:

1. $T_C = 25^{\circ}\text{C}$.

2. Limited only by maximum temperature allowed.

3. $V_{DD} = 40V, V_{GS} = 10V, L = 0.5\text{mH}, R_g = 25\Omega$ Starting $T_J = 25^{\circ}\text{C}$.

4. Pulse Test : Pulse Width $\leq 380\mu\text{s}$, duty cycle $\leq 2\%$.

5. Device mounted on 1 in² FR-4 board with 2oz. single-sided Copper, in a still air environment with $T_A = 25^{\circ}\text{C}$.

Typical Characteristics ($T_J = 25^\circ\text{C}$, unless otherwise specified)

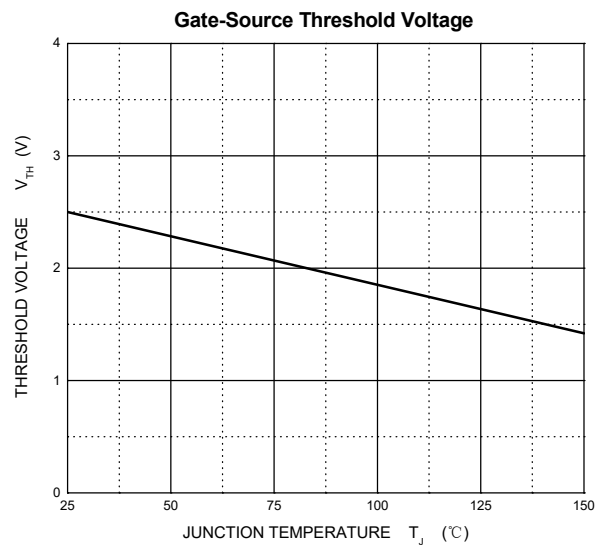
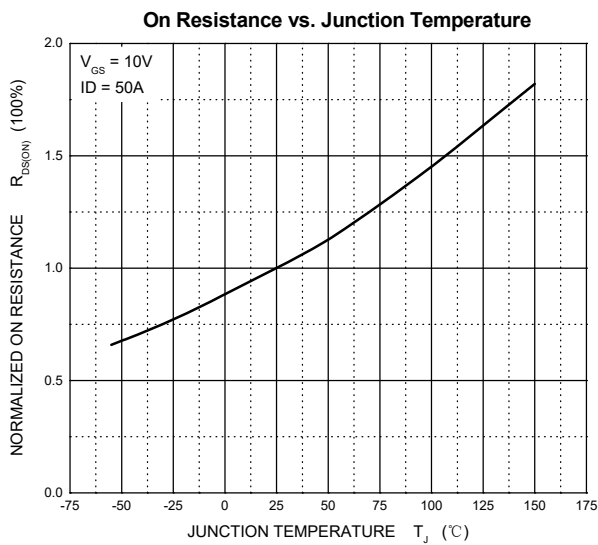
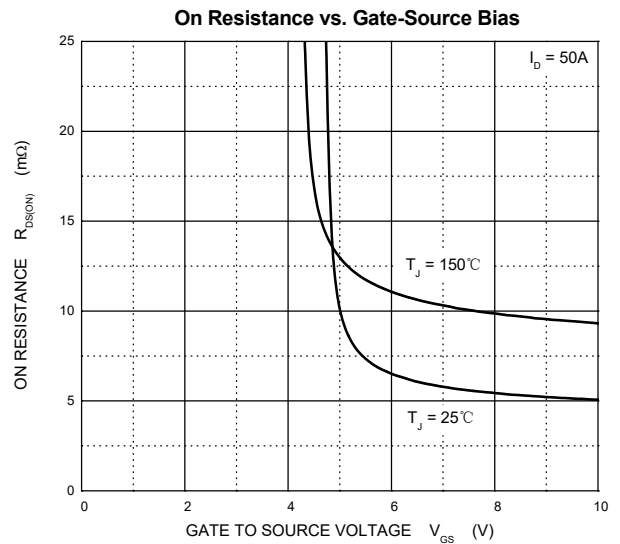
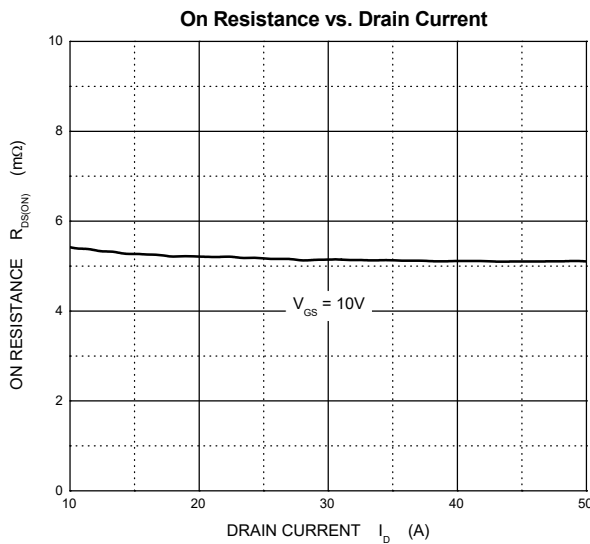
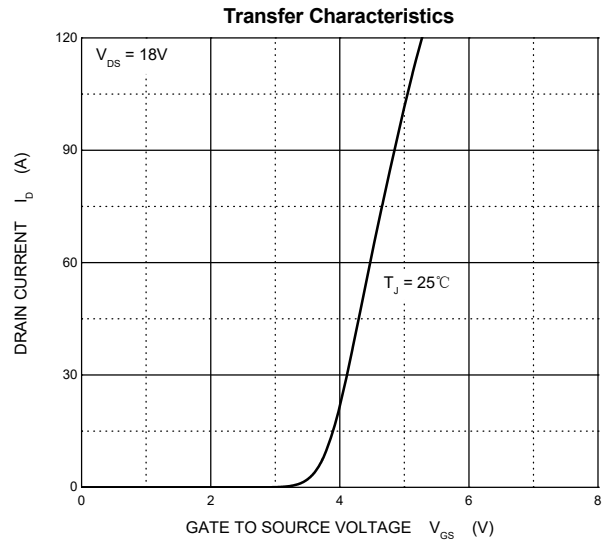
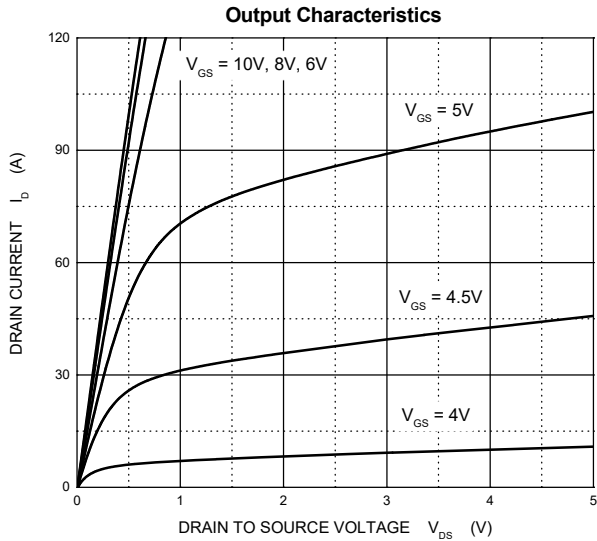

Typical Characteristics ($T_J = 25^\circ\text{C}$, unless otherwise specified)

Typical Capacitances

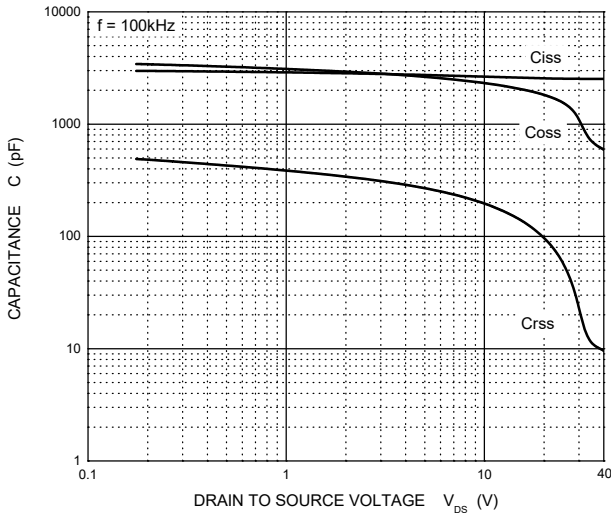

Gate Charge

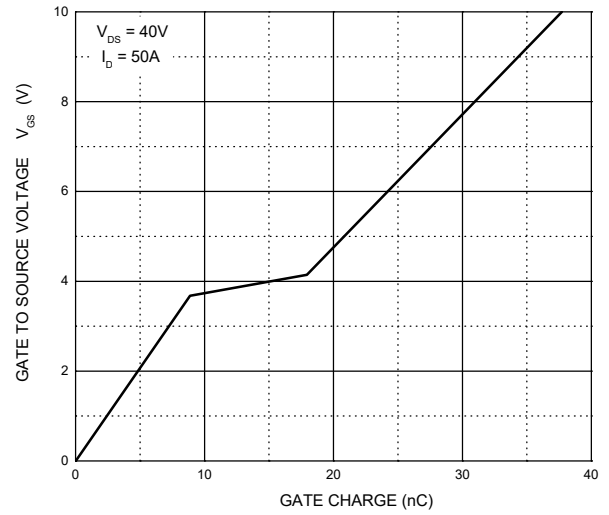

Source-Drain Diode Forward Characteristics

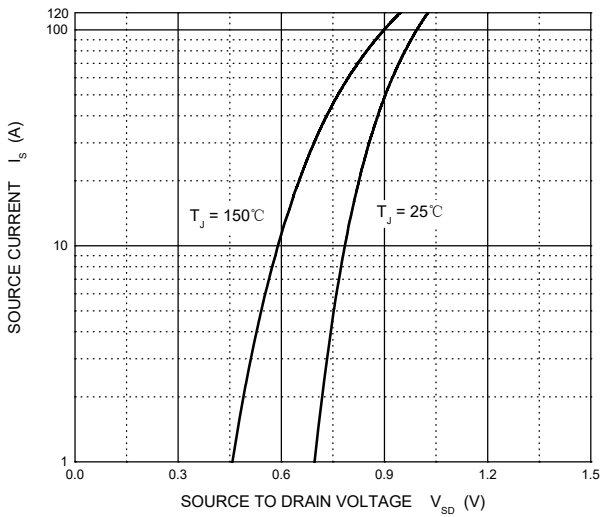

Maximum Safe Operating Area

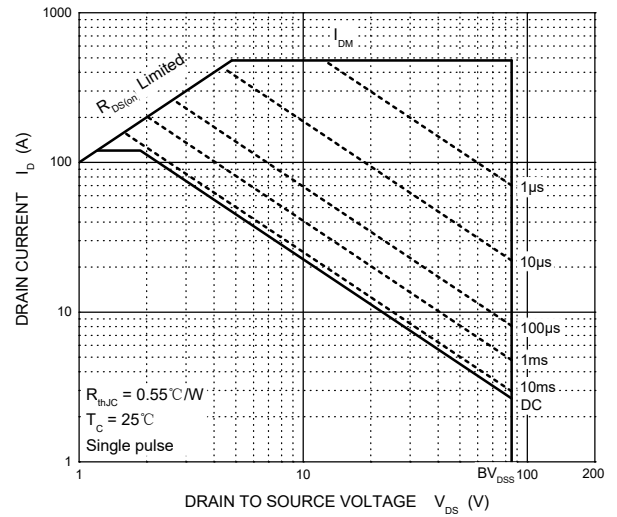

Transient Thermal Impedance, Junction-Case

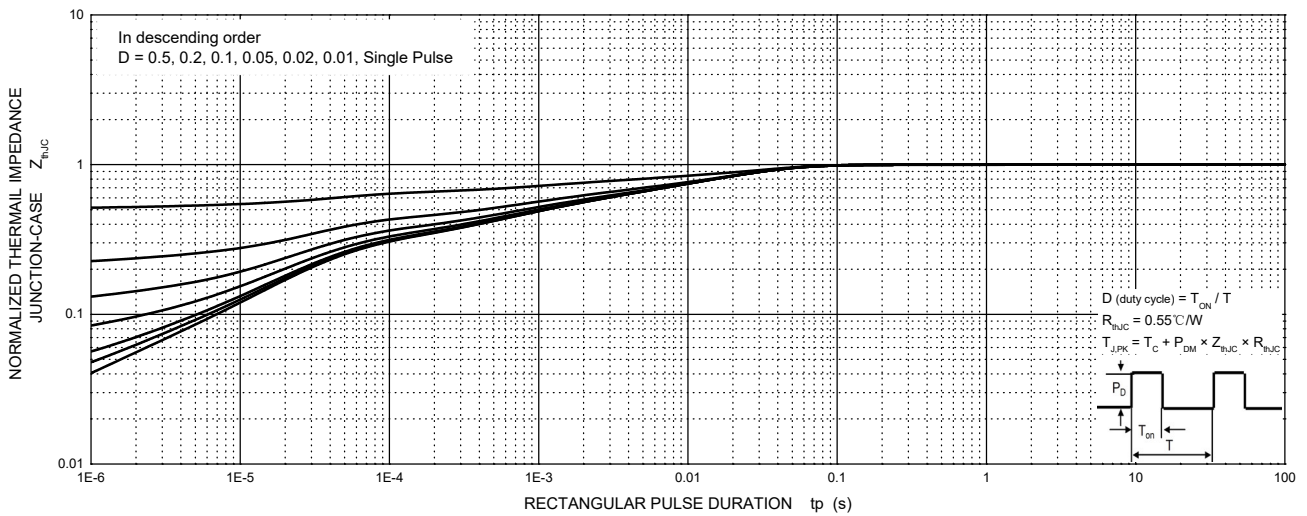

TEST CIRCUIT AND WAVEFORMS

Gate Charge



Resistive Load Switching Time

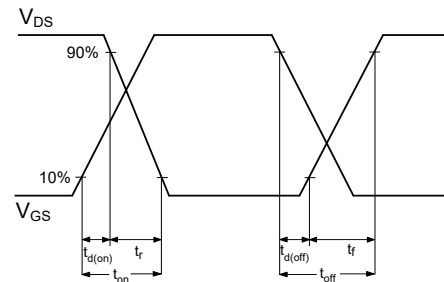
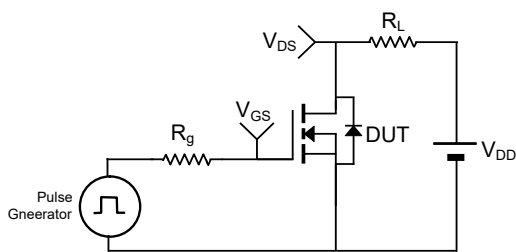

Un-clamped Inductive Load Switching

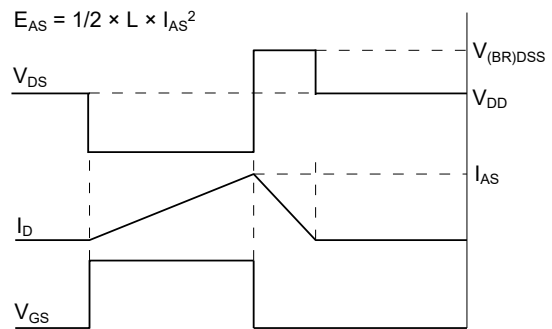
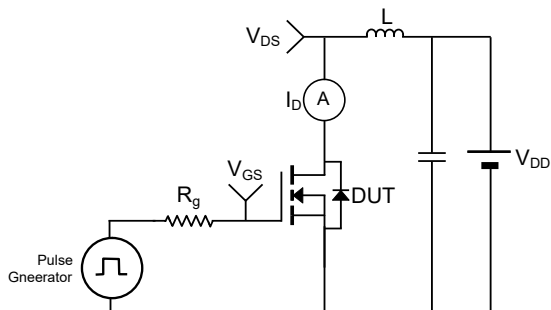

Drain-Source Body Diode Reverse Recovery

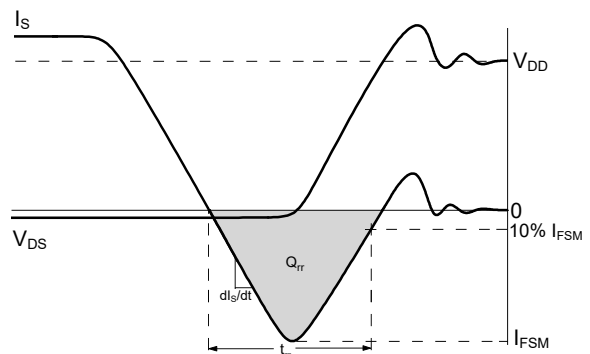
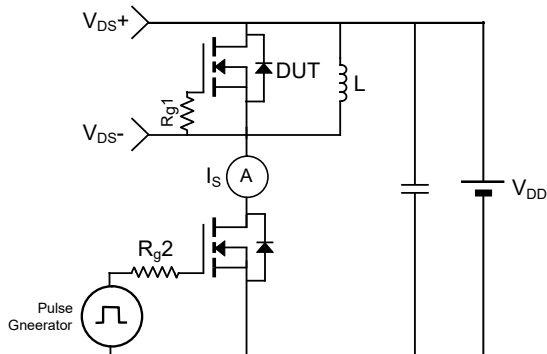

TO-263-2L Package Outline Dimensions

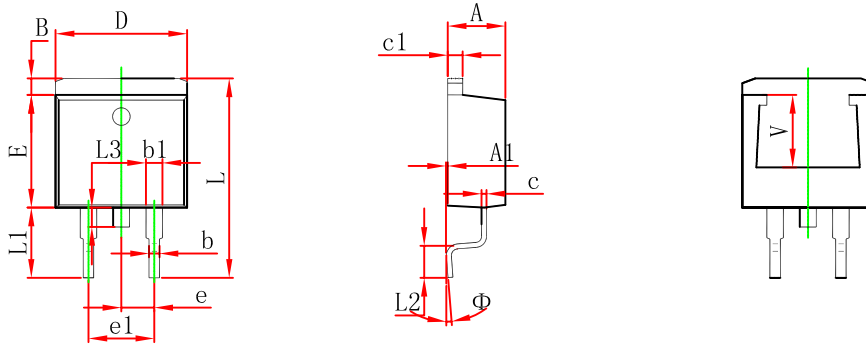

Symbol	Dimensions In Millimeters		Dimensions In Inches	
	Min.	Max.	Min.	Max.
A	4.470	4.670	0.176	0.184
A1	0.000	0.150	0.000	0.006
B	1.120	1.420	0.044	0.056
b	0.710	0.910	0.028	0.036
b1	1.170	1.370	0.046	0.054
c	0.310	0.530	0.012	0.021
c1	1.170	1.370	0.046	0.054
D	10.010	10.310	0.394	0.406
E	8.500	8.900	0.335	0.350
e	2.540 TYP.		0.100 TYP.	
e1	4.980	5.180	0.196	0.204
L	14.940	15.500	0.588	0.610
L1	4.950	5.450	0.195	0.215
L2	2.340	2.740	0.092	0.108
L3	1.300	1.700	0.051	0.067
Φ	0° 8°		0° 8°	
V	5.600 REF.		0.220 REF.	

TO-263-2L Suggested Pad Layout

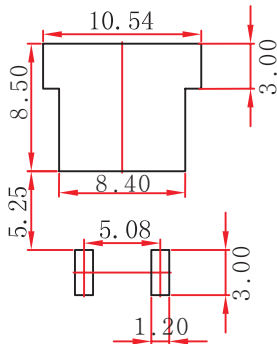

Note:

1. Controlling dimension: in millimeters.
2. General tolerance: $\pm 0.05\text{mm}$.
3. The pad layout is for reference purposes only.

NOTICE

JSCJ reserves the right to make modifications, enhancements, improvements, corrections or other changes without further notice to any product herein. JSCJ does not assume any liability arising out of the application or use of any product described herein.

TO-263-2L Tape and Reel

TO-263-2L Embossed Carrier Tape

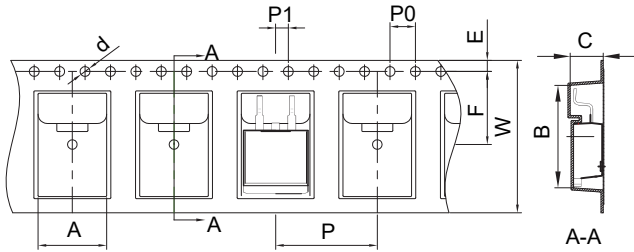

Packaging Description:

TO-263-2L parts are shipped in tape. The carrier tape is made from a dissipative (carbon filled) polycarbonate resin. The cover tape is a multilayer film (Hear Activated Adhesive in nature) primarily composed of polyester film, adhesive layer, sealant, and anti-static sprayed agent. These reeled parts in standard option are shipped with 800 units per 13" or 33.0 cm diameter reel. The reels are clear in color and is made of polystyrene plastic (anti-static coated).

Dimensions are in millimeter										
Pkg type	A	B	C	d	E	F	P0	P	P1	W
TO-263	10.80	16.13	5.21	Φ1.55	1.75	11.50	4.00	16.00	2.00	24.00

TO-263-2L Tape Leader and Trailer

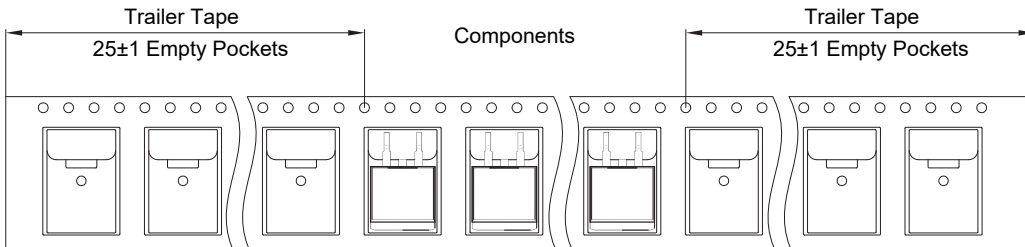

TO-263-2L Reel

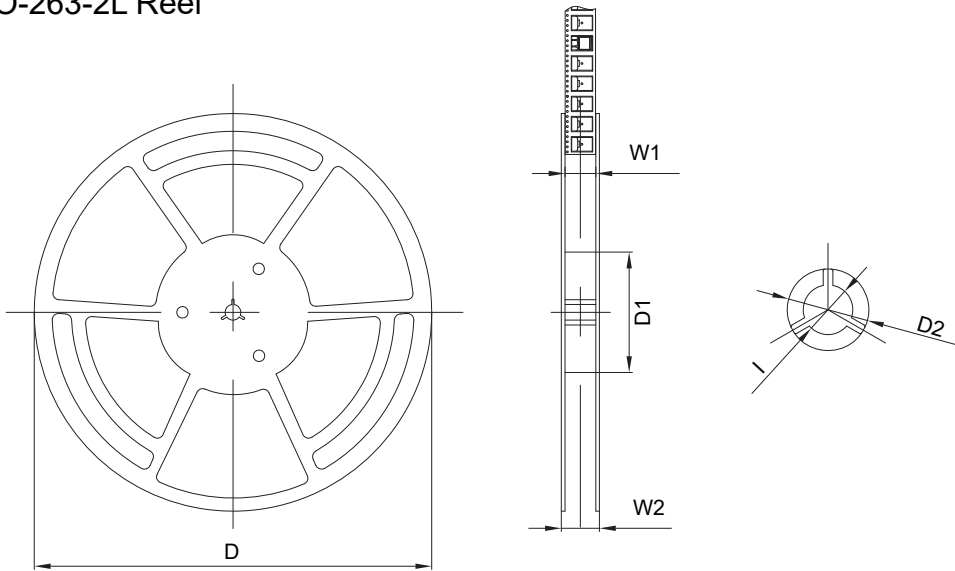

Dimensions are in millimeter						
Reel	D	D1	D2	W1	W2	l
13" Dia	330.00	100.00	Φ21.00	24.40	30.40	Φ13.00

Reel	Reel Size	Box	Box Size(mm)	Carton	Carton Size(mm)
800 pcs	13 inch	1600 pcs	360×360×65	8000 pcs	378×358×382