

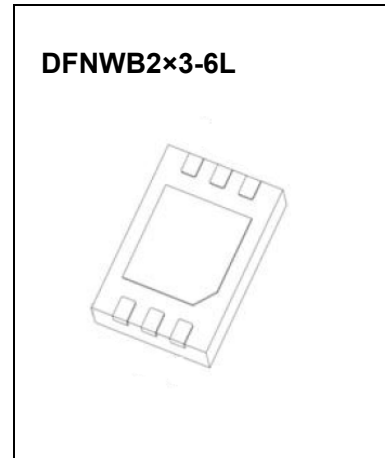

**DFNWB2×3-6L Plastic-Encapsulate MOSFETS**

**CJCD2007A Dual N-Channel MOSFET**

$V_{(BR)DSS}$	$R_{DS(on)TYP}$	$I_D$
20V	10.5mΩ@10V	8A
	11.3mΩ@4.5V	
	11.7mΩ@3.8V	
	14.5mΩ@2.5V	



**GENERAL DESCRIPTION**

The CJCD2007A uses advanced trench technology to provide excellent  $R_{DS(ON)}$  and low gate charge. It is ESD protected. This device is suitable for use as a uni-directional or bi-directional load switch, facilitated by its common-drain configuration.

**MARKING**



Top

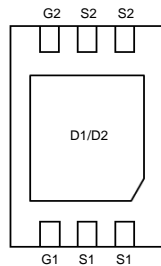

Back

2007A = Part No.  
 Solid dot = Pin1 indicator.  
 XX = Code.

**Equivalent Circuit**

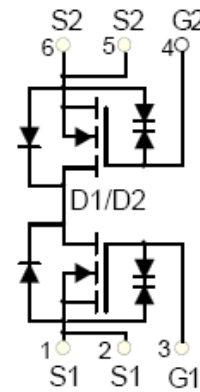

**ABSOLUTE MAXIMUM RATINGS ( $T_a=25^{\circ}C$  unless otherwise noted)**

Parameter	Symbol	Value	Unit
Drain-Source Voltage	$V_{DS}$	20	V
Gate-Source Voltage	$V_{GS}$	±10	V
Continuous Drain Current	$I_D$	8	A
Pulsed Drain Current	$I_{DM}^{①}$	45	A
Maximum Power Dissipation	$P_D^{④}$	1.5	W
Thermal Resistance from Junction to Ambient	$R_{\theta JA}^{④}$	83.3	$^{\circ}C/W$
Operating Junction and Storage Temperature Range	$T_J, T_{stg}$	-55~+150	$^{\circ}C$

# MOSFET ELECTRICAL CHARACTERISTICS

$T_a=25^\circ\text{C}$  unless otherwise specified

Parameter	Symbol	Test Condition	Min	Typ	Max	Unit
<b>Off characteristics</b>						
Drain-source breakdown voltage	$V_{(BR)DSS}$	$V_{GS} = 0V, I_D = 250\mu A$	20			V
Zero gate voltage drain current	$I_{DSS}$	$V_{DS} = 16V, V_{GS} = 0V$			1	$\mu A$
Gate-body leakage current	$I_{GSS}$	$V_{DS} = 0V, V_{GS} = \pm 10V$			$\pm 10$	
<b>On characteristics</b> <sup>②</sup>						
Gate-threshold voltage	$V_{GS(th)}$	$V_{DS} = V_{GS}, I_D = 250\mu A$	0.4	0.8	1.0	V
Static drain-source on-state resistance	$R_{DS(on)}$	$V_{GS} = 10V, I_D = 3A$	7.4	10.5	13.7	$m\Omega$
		$V_{GS} = 4.5V, I_D = 3A$	7.9	11.3	14.7	
		$V_{GS} = 3.8V, I_D = 3A$	8.2	11.7	15.2	
		$V_{GS} = 2.5V, I_D = 3A$	10.2	14.5	18.9	
<b>Dynamic characteristics</b> <sup>③</sup>						
Input capacitance	$C_{iss}$	$V_{DS} = 10V, V_{GS} = 0V,$ $f = 1MHz$		762		$pF$
Output capacitance	$C_{oss}$			109		
Reverse transfer capacitance	$C_{rss}$			86		
<b>Switching characteristics</b> <sup>③</sup>						
Total gate charge	$Q_g$	$V_{GS} = 4.5V,$ $V_{DS} = 10V, I_D = 7A$		7.5		$nC$
Gate-source charge	$Q_{gs}$			1.1		
Gate-drain charge	$Q_{gd}$			2.8		
Turn-on delay time	$t_{d(on)}$	$V_{DS} = 10V,$ $V_{GS} = 5V, R_G = 3\Omega,$ $R_L = 1.5\Omega$		6.9		$ns$
Turn-on rise time	$t_r$			4.5		
Turn-off delay time	$t_{d(off)}$			26.1		
Turn-off fall time	$t_f$			9.3		
<b>Drain-Source Diode Characteristics</b>						
Drain-source diode forward voltage	$V_{SD}$ <sup>②</sup>	$V_{GS} = 0V, I_S = 1.0A$			1.2	V
Continuous drain-source diode forward current	$I_S$				8	A
Pulsed drain-source diode forward current	$I_{SM}$ <sup>①</sup>				45	A

Notes:

1.  $P_w \leq 10\mu s$ , Duty cycle  $\leq 1\%$ .

2. Pulse Test : Pulse Width  $\leq 300\mu s$ , duty cycle  $\leq 2\%$ .

3. Guaranteed by design, not subject to production.

4. Device is single-side active, mounted on 1 in<sup>2</sup> FR-4 board with 2oz.Copper, in a still air environment with  $T_A = 25^\circ C, t \leq 10$  sec.

# Typical Characteristics ( $T_J = 25^\circ\text{C}$ , unless otherwise specified)

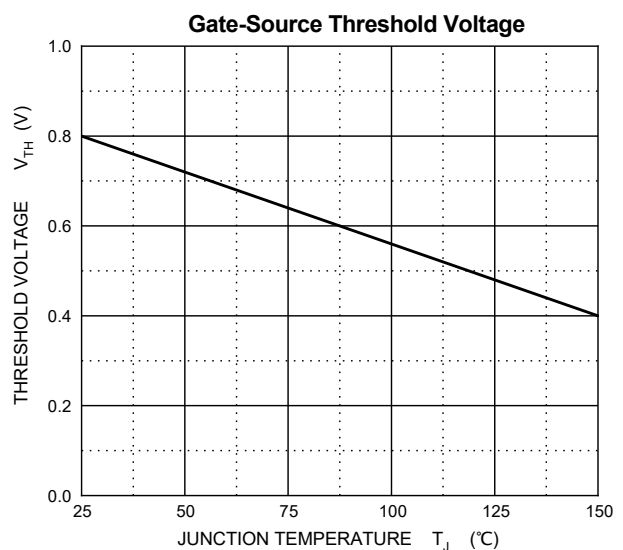
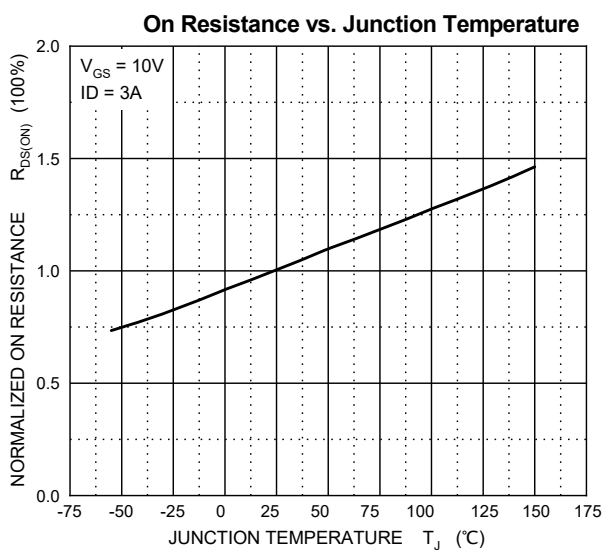
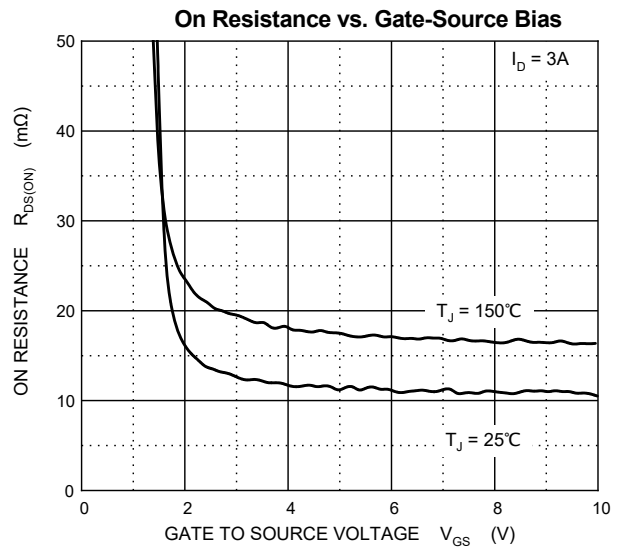
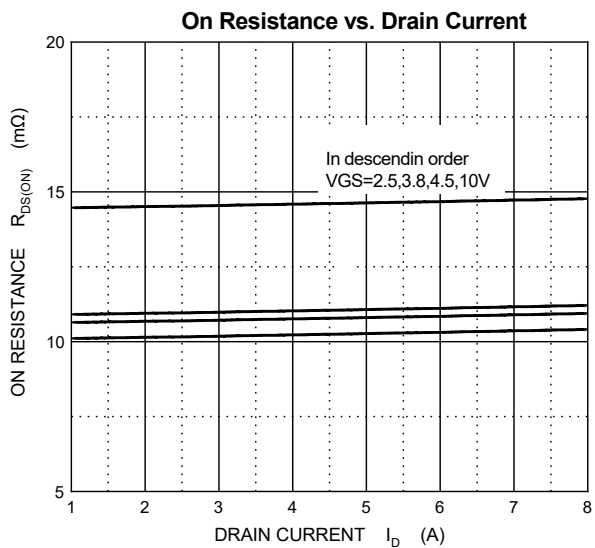
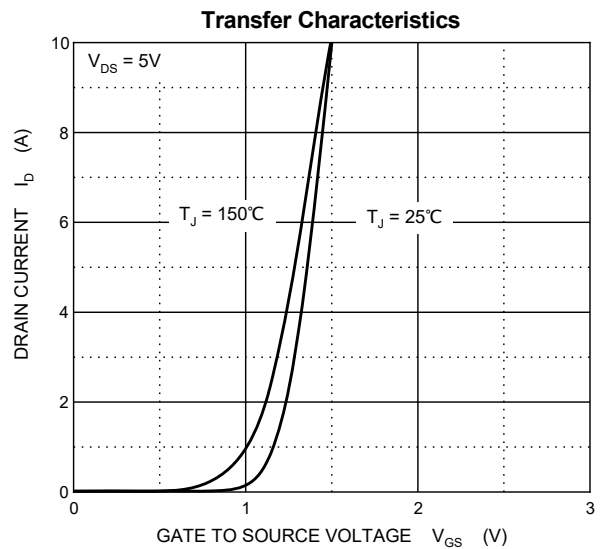
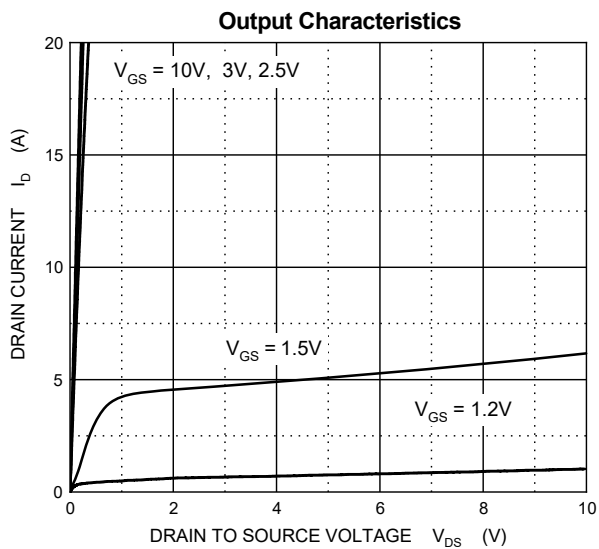

# Typical Characteristics ( $T_J = 25^\circ\text{C}$ , unless otherwise specified)

**Typical Capacitances**

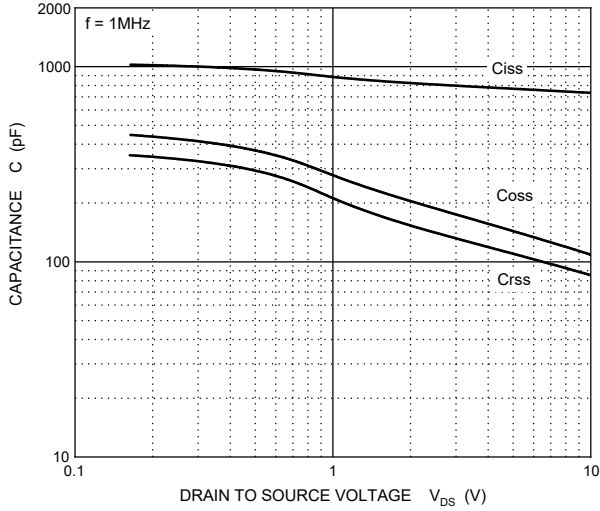

**Gate Charge**

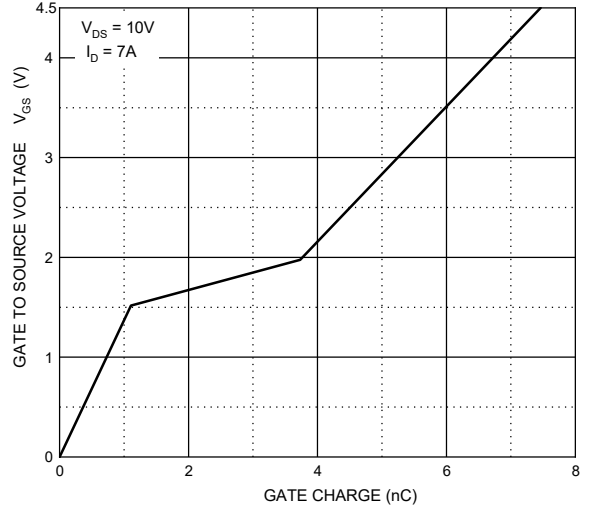

**Source-Drain Diode Forward Characteristics**

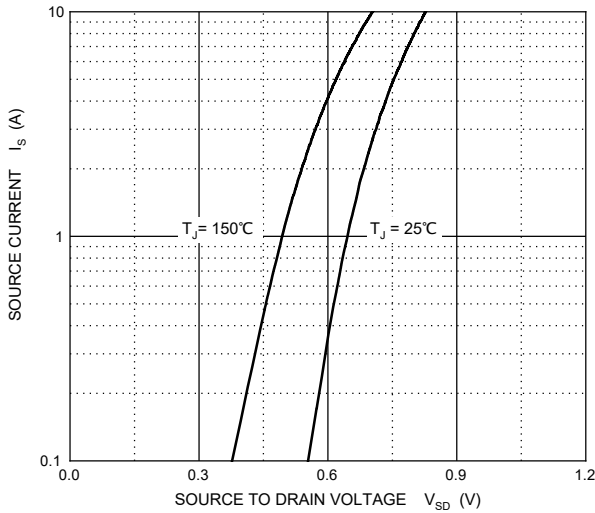

**Maximum Safe Operating Area**

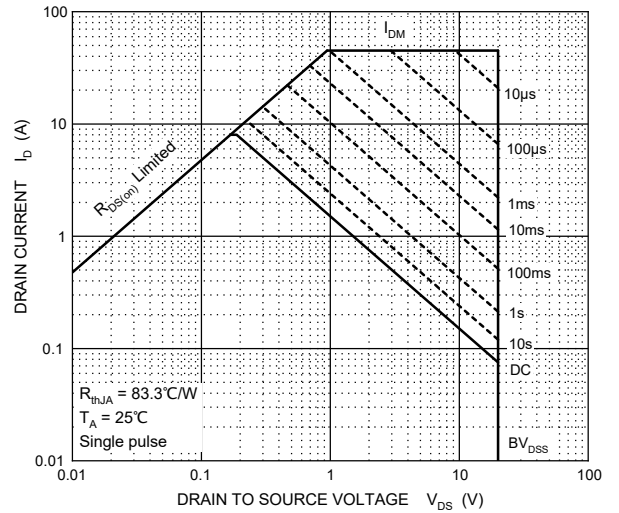

**Transient Thermal Impedance, Junction-Ambient**

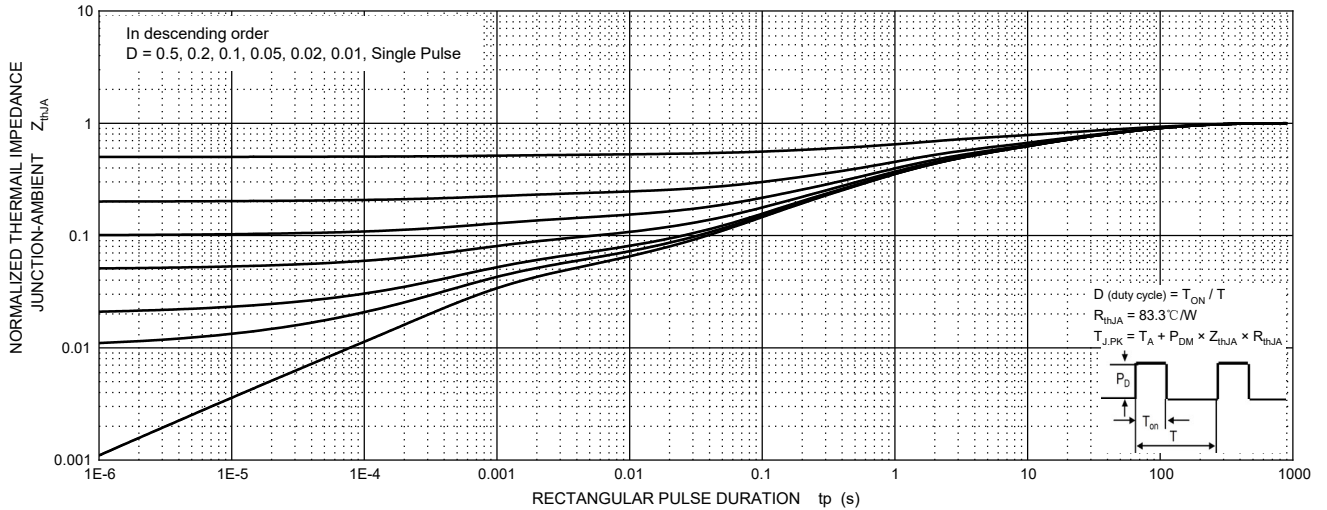

## DFNWB2 × 3-6L Package Outline Dimensions (Unit:mm)

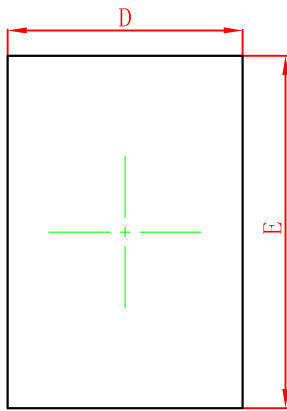

TOP VIEW

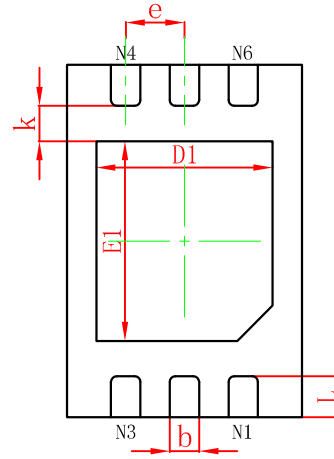

BOTTOM VIEW

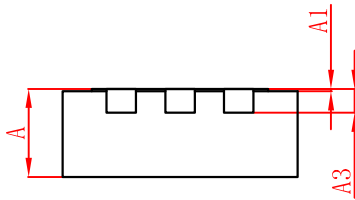

SIDE VIEW

Symbol	Dimensions In Millimeters		Dimensions In Inches	
	Min.	Max.	Min.	Max.
A	0.700	0.800	0.028	0.031
A1	0.000	0.050	0.000	0.002
A3	0.203REF.		0.008REF.	
D	1.950	2.050	0.077	0.081
E	2.950	3.050	0.116	0.120
D1	1.450	1.550	0.057	0.061
E1	1.650	1.750	0.065	0.069
k	0.200MIN.		0.008MIN.	
b	0.200	0.300	0.008	0.012
e	0.500TYP.		0.020TYP.	
L	0.300	0.400	0.012	0.016

## DFNWB2 × 3-6L Suggested Pad Layout

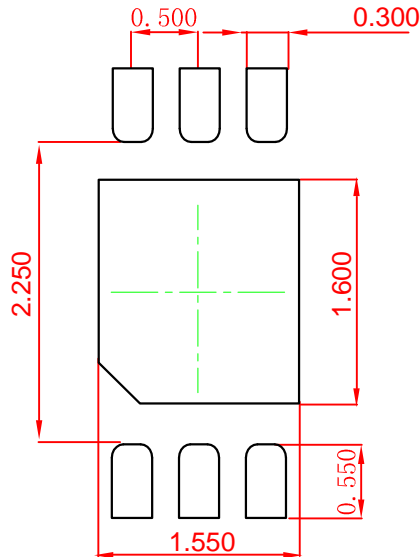

Note:

1. Controlling dimension: in millimeters.
2. General tolerance:  $\pm 0.050$ mm.
3. The pad layout is for reference purposes only.

### NOTICE

JSCJ reserves the right to make modifications, enhancements, improvements, corrections or other changes without further notice to any product herein. JSCJ does not assume any liability arising out of the application or use of any product described herein.

# DFNWB2X3-6L Tape and Reel

## DFNWB2X3-6L Embossed Carrier Tape

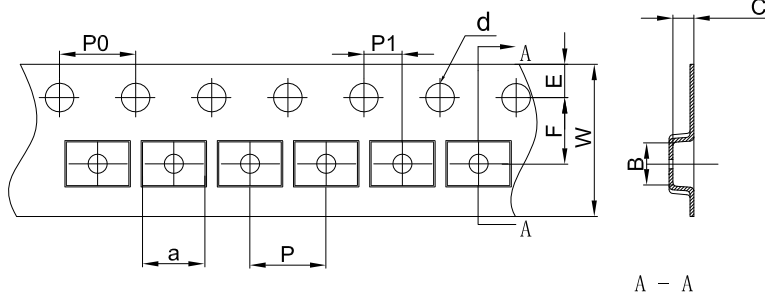

### Packaging Description:

**DFNWB2X3-6L** parts are shipped in tape. The carrier tape is made from a dissipative (carbon filled) polycarbonate resin. The cover tape is a multilayer film (Heat Activated Adhesive in nature) primarily composed of polyester film, adhesive layer, sealant, and anti-static sprayed agent. These reeled parts in standard option are shipped with 3,000 units per 7" or 18.0cm diameter reel. The reels are clear in color and is made of polystyrene plastic (anti-static coated).

Dimensions are in millimeter

Pkg type	a	B	C	d	E	F	P0	P	P1	W
DFNWB2X3-6L	3.30	2.30	1.10	Ø1.50	1.75	3.50	4.00	4.00	2.00	8.00

## DFNWB2X3-6L Tape Leader and Trailer

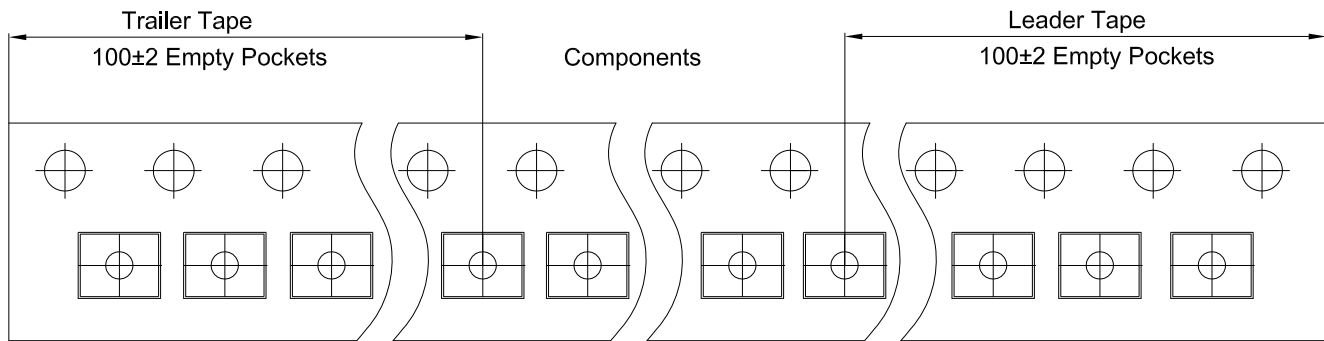

## DFNWB2X3-6L Reel

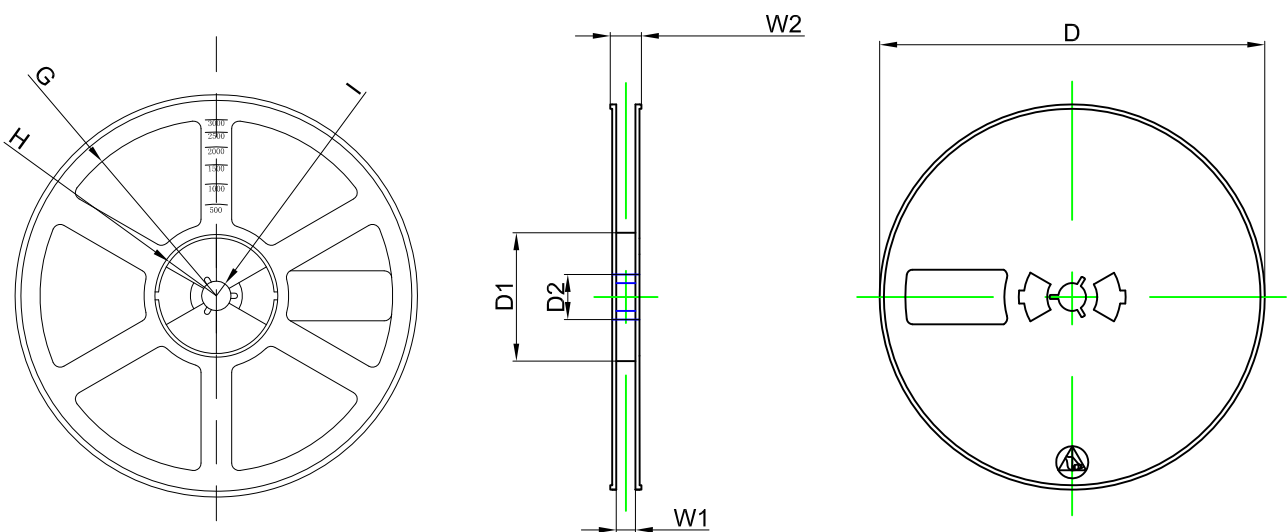

Dimensions are in millimeter

Reel Option	D	D1	D2	G	H	I	W1	W2
7" Dia	Ø180.00	60.00	13.00	R78.00	R25.60	R6.50	9.50	13.10

REEL	Reel Size	Box	Box Size(mm)	Carton	Carton Size(mm)	G.W.(kg)
3000 pcs	7 inch	30,000 pcs	203×203×195	120,000 pcs	438×438×220	