



CJDR8837 Motor Driver

1 Introduction

CJDR8837 is a 12V, single channel, full bridge motor drive integrated circuit. It supports 12V power input supply voltage and can provide up to 1.5A continuous output current. In sleep mode, its power consumption current is less than 1 μ A. In addition, CJDR8837 integrates functions such as thermal shutdown, under-voltage protection, output short-circuit protection and over-current protection.

CJDR8837 has a PWM (IN / IN) input interface and is compatible with industry standard devices. Therefore, CJDR8837 is very suitable for providing integrated motor drive solutions for cameras, consumer products, toys and other low-voltage or battery powered motion control applications.

2 Available Package

PART NUMBER	PACKAGE
CJDR8837	DFNWB2 \times 2-8L

Note: For more detailed packaging information, see the part *Pin Configuration and Function* and the part *Mechanical Information*.

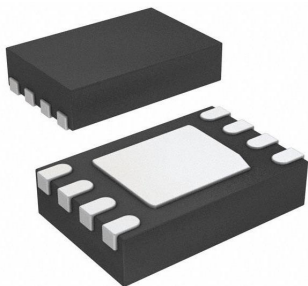

Figure 2-1. DFN2 \times 2-8L Package

3 Features

- H-bridge Motor Driver
- Load Power Supply Voltage: 0 ~ 12V
- Low Conducting Internal Resistance: 350m Ω (HS + LS)
- Drive Output Current: 1.5A (Continuous)
- PWM (IN 1 / IN 2) Input Mode
- Compatible with 3.3V, 5.0V Logic Input
- Thermal Shutdown Protection
- Build-in Output Current Limit
- Short Circuit Protection
- Under-voltage Protection
- Low Consumption Current in Sleep Mode: nA level (when nSleep = 0)

4 Applications

- Video Camera
- Digital Single Lens Reflective Lens
- Toys
- Robotics
- Shared Bicycle Lock
- Water Meter Switch
- Medical Equipment

5 Pin Configuration and Function

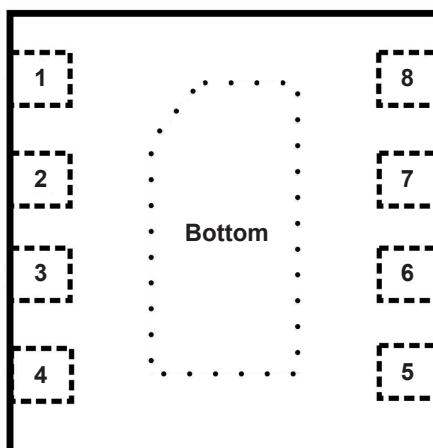

Figure 5-1. Package Pin Map

PIN NAME	CJDR8837	I / O	DESCRIPTION
	DFNWB2×2-8L		
V _M	1	Power	Load power supply.
OUT 1	2	O	H-bridge output 1.
OUT 2	3	O	H-bridge output 2.
GND	4	Ground	Device ground. Connect to system ground.
IN 2	5	I	H-bridge control input 2.
IN 1	6	I	H-bridge control input 1.
nSleep	7	I	Sleep mode control input, active at low level.
V _{CC}	8	Power	Logic power supply.
-	Bottom	-	Connect to system ground.

6 Specifications

6.1 Absolute Maximum Ratings⁽¹⁾

(over operating free-air temperature range, unless otherwise specified)

CHARACTERISTIC	SYMBOL	VALUE	UNIT
Load power input voltage range ⁽²⁾	V_M	0 ~ 16	V
Logic power input voltage range ⁽²⁾	V_{CC}	-0.3 ~ 7.0	
Logic input voltage range ⁽²⁾	V_{INx}	-0.5 ~ 7.0	
Continuous output current	I_{OUT}	±1.5	A
Peak output current	$I_{OUT Max}$	±2.5	
Maximum junction temperature	T_J	150	°C
Storage temperature	T_{stg}	-60 ~ 150	°C

(1) Stresses beyond those listed under *Absolute Maximum Ratings* may cause permanent damage to the device. These are stress ratings only, which do not imply functional operation of the device at these or any other conditions beyond those indicated under *Recommended Operating Conditions*. Exposure to absolute-maximum rated conditions for extended periods may affect device reliability.

(2) All voltages are with respect to network ground terminal.

6.2 Recommended Operating Conditions⁽³⁾

PARAMETER	SYMBOL	MIN.	NOM.	MAX.	UNIT
Load power input voltage range	V_M	0	-	12	V
Logic power input voltage range	V_{CC}	2.0	-	7.0	V
Continuous output current	I_{OUT}	0	-	1.5	A
External PWM frequency	f_{PWM}	0	-	400	kHz
Operating junction temperature	T_J	-40	-	150	°C
Operating ambient temperature ⁽⁴⁾	T_A	-40	-	85	°C

(3) JSCJ recommends that users should not exceed the rated value in the *Recommended Operating Conditions* for the application conditions of the equipment, so as to ensure the stability of normal operation and reliability of long-term operation of the equipment. Operation beyond the recommended rated conditions does not mean that the product will fail. The consumers need to evaluate the risks that may be caused by the operation of the product beyond the recommended rated conditions.

(4) It is necessary to ensure that the operating junction temperature of the equipment does not exceed the rated value of the recommended operating conditions when using the device for design.

6 Specifications

6.3 ESD Ratings

ESD RATINGS		SYMBOL	VALUE	UNIT
Electrostatic discharge ⁽⁵⁾	Human body model	$V_{ESD-HBM}$	5000	V

(5) ESD testing is conducted in accordance with the relevant specifications formulated by the Joint Electronic Equipment Engineering Commission (JEDEC). The human body mode (HBM) electrostatic discharge test is based on the JESD22-114D test standard, using a 100pF capacitor and discharging to each pin of the device through a resistance of 1.5kΩ.

6.4 Electrical Characteristics

CJDR8837 ($V_{CC} = 3.0V$, $V_M = 12V$, $T_A = 25^\circ C$, unless otherwise specified)

CHARACTERISTIC	SYMBOL	TEST CONDITIONS	MIN.	TYP. ⁽⁶⁾	MAX.	UNIT
Power Supply						
V_{CC} working current	I_{VCC}	No PWM input	-	368	450	μA
		$f_{PWM} = 50kHz$	-	680	1000	
V_{CC} standby current	$I_{VCC Q}$	nSleep = 0	-	40	80	nA
V_M working current	I_{VM}	No PWM input	-	214	550	μA
		$f_{PWM} = 50kHz$	-	580	900	
V_M standby current	$I_{VM Q}$	nSleep = 0	-	1.3	20	nA
Output H-bridge						
High side + low side bridge conduction resistance	$R_{DS ON}$	$I_{OUT} = 500mA$, $T_J = 25^\circ C$	-	350	450	mΩ
		$I_{OUT} = 500mA$, $T_J = 125^\circ C$	-	530	700	
Off-state leakage current	I_{OFF}	$V_{OUT} = 0V$	-10	-	10	μA
Logic Input Pin (IN 1, IN 2, nSleep)						
Logic input low voltage	V_{IL}	High level to low level	-	1.28	-	V
Logic input high voltage	V_{IH}	Low level to high level	-	1.58	-	V
Logic input hysteresis	$V_{IH Y}$	$V_{IN} = 3.3V$	-	0.3	-	V
Logic input low current	I_{IL}	$V_{IN} = 0V$	-5	-	5	μA
Logic input high current	I_{IH}	$V_{IN} = 3.3V$	-	30	-	μA
nSleep low	V_{nSL}	High level to low level	-	1.28	-	V
nSleep high	V_{nSH}	Low level to high level	-	1.58	-	V
nSleep hysteresis	$V_{nSH Y}$	$V_{IN} = 3.3V$	-	0.3	-	V
nSleep high current	I_{nSH}	$V_{IN} = 3.3V$	-	30	-	μA
Pull down resistance	R_{PD}	IN x pins and nSleep pin	-	100	-	kΩ

6 Specifications

6.4 Electrical Characteristics (continued)

CJDR8837 ($V_{CC} = 3.0V$, $V_M = 12V$, $T_A = 25^\circ C$, unless otherwise specified)

CHARACTERISTIC	SYMBOL	TEST CONDITIONS	MIN.	TYP. ⁽⁶⁾	MAX.	UNIT
Protection Circuits						
Thermal shutdown temperature	T_{SD}	-	155	169	180	$^\circ C$
Thermal shutdown hysteresis	ΔT_{SD}	-	-	26	-	$^\circ C$
Undervoltage protection voltage	V_{UVLO}	V_{CC} power supply	-	1.9	-	V
Undervoltage protection hysteresis	ΔV_{UVLO}	V_{CC} power supply	-	1.8	-	V
Output current limit	$I_{OUT\ Limit}$	High side	-	3.0	-	A
		Low side	-	3.0	-	
OCP delay time	t_D	-	-	1.5	-	μs
OCP retry time	t_R	-	-	1.5	-	ms

Note:

(6) Typical numbers are at $25^\circ C$ and represent the most likely norm.

6.5 Time Series Parameters and Curves

CHARACTERISTIC	SYMBOL	TEST CONDITIONS	MIN.	TYP. ⁽⁶⁾	MAX.	UNIT
Start-up time	T1	-	-	-	300	ns
Shutdown time	T2	-	-	-	220	ns
Input high to output high delay	T3	-	-	-	160	ns
Input low to output low delay	T4	-	-	-	160	ns
Output rising edge time	T5	-	10	-	188	ns
Output drop edge time	T6	-	10	-	188	ns

Note:

(6) Typical numbers are at $25^\circ C$ and represent the most likely norm.

6 Specifications

6.5 Time Series Parameters and Curves (continued)

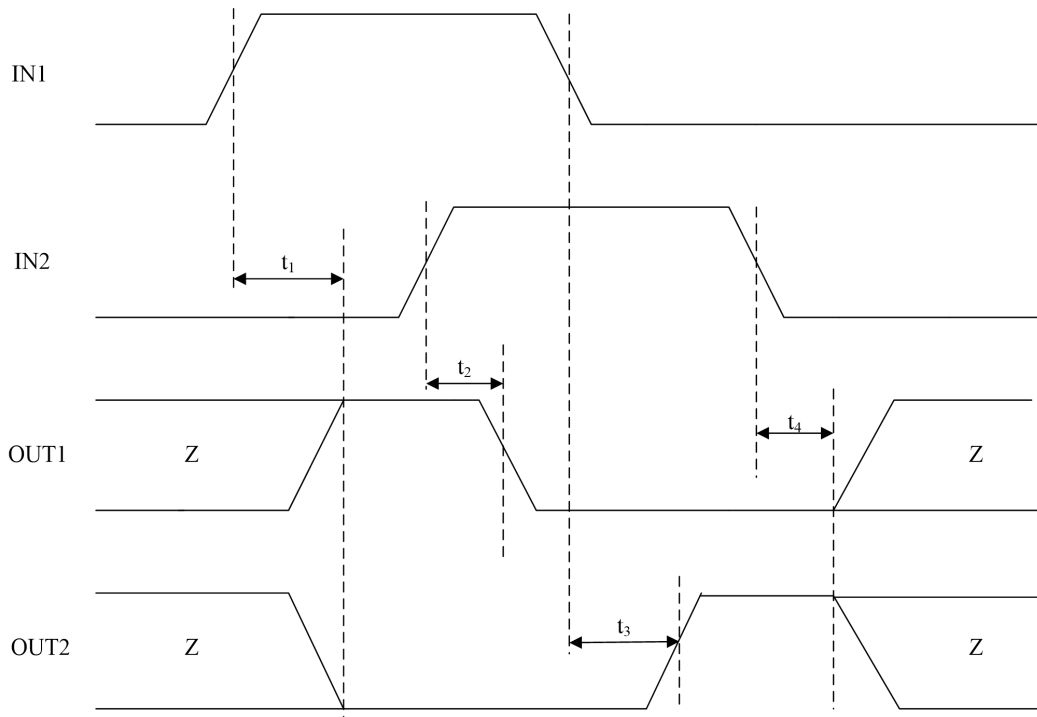

Figure 6-1. Input and Output Parameter Curve 1 (T1, T2, T3, T4)

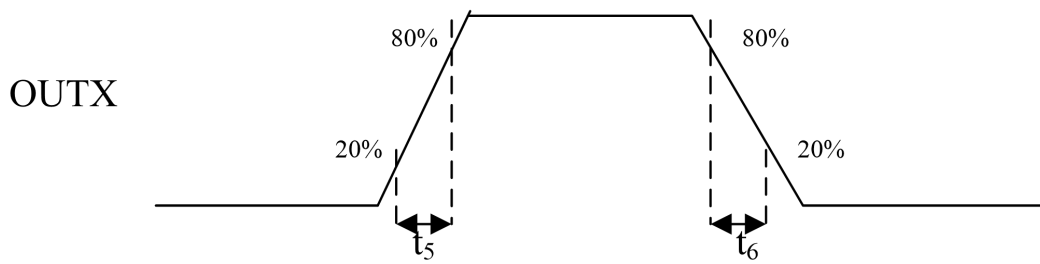

Figure 6-2. Input and Output Parameter Curve 2 (T5, T6)

7 Detailed Description

7.1 Description

CJDR8837 is a 12V DC motor drive integrated circuit, which integrates thermal shutdown, under-voltage protection, output short circuit protection and current limit protection mechanism. It is compatible with industry standard devices and has PWM (IN / IN) interface. A single CJDR8837 can be used as the DC motor drive, or two CJDR8837 can be used as the stepping motor drive.

7.2 Functional Block Diagram

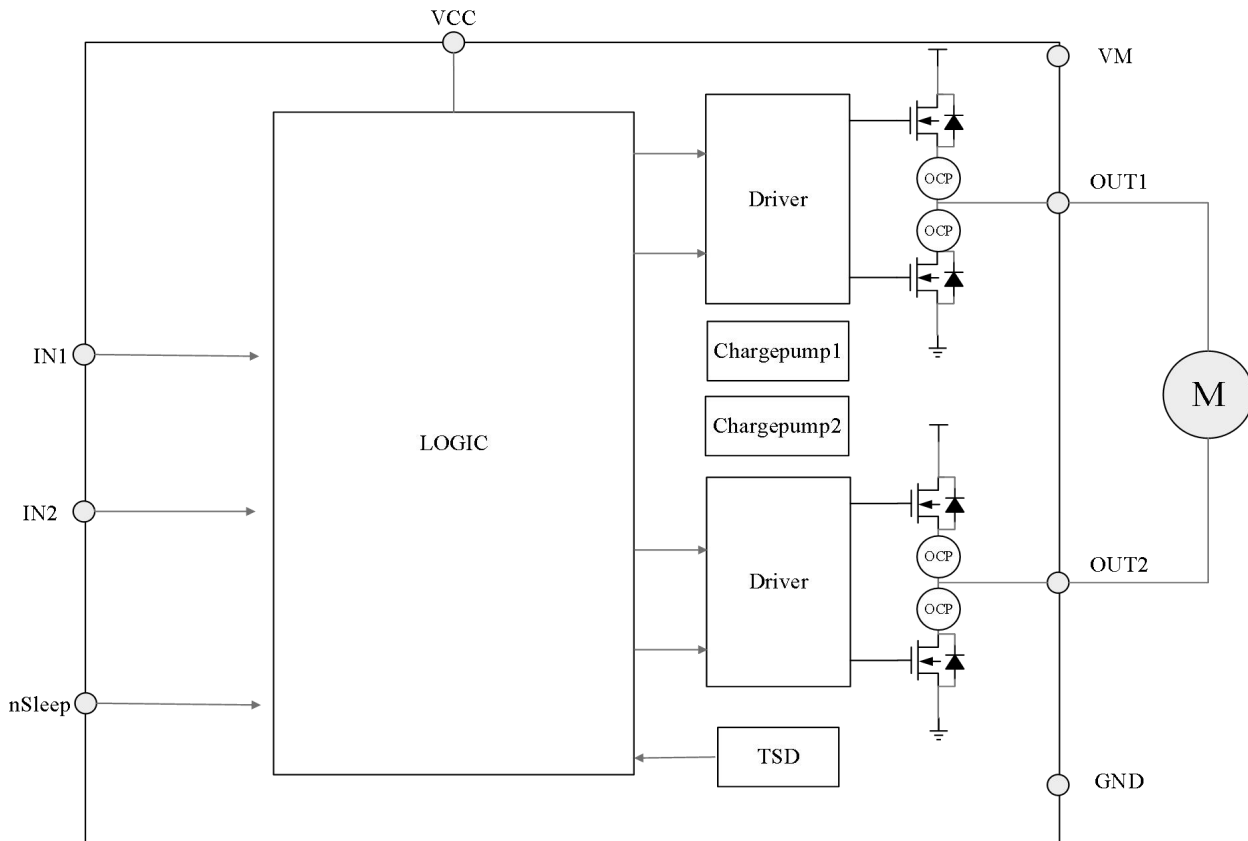

7 Detailed Description

7.3 Feature Description

PWM Control Mode

CJDR8837 is controlled by PWM input interface, also known as IN / IN input mode, the PWM interface (IN 1 / IN 2) controls the OUT x pins according to the logic table in Table 7-1.

Table 7-1. PWM Control Mode with Automatic Sleep

nSleep	IN 1	IN 2	OUT 1	OUT 2	DESCRIPTION
0	X	X	X	X	Sleep mode
1	0	0	Hi-Z	Hi-Z	Free rotation
1	0	1	L	H	Reverse (OUT 2 → OUT 1)
1	1	0	H	L	Forward (OUT 1 → OUT 2)
1	1	1	L	L	Brake (low-side slow decay)

Output Driver

Power NMOS is used for the high side and low side of output drive, and charge pump circuit is built in. The sum of internal resistances of the high side and low side is as low as 350mΩ (typical).

Sleep Mode

When nSleep is high, the device will work normally.

When nSleep is low, the device will enter the sleep mode of low power consumption. In the sleep mode, the power consumption current of the device is at the level of nA, which is suitable for application in systems requiring low power consumption.

The built-in 100kΩ resistor of nSleep is pulled down to GND. When the external input is suspended, it defaults to sleep mode.

Input Pin

There is a 100kΩ resistance pull-down inside the input pin, and the default is low-level input.

Thermal Shutdown Protection

When the chip junction temperature exceeds 169°C (Typ.), the thermal shutdown protection circuit is activated and all output tubes are turned off. When the temperature decreases by a hysteresis temperature of 26°C (Typ.), the output tube returns to work.

Although the internal protection circuitry of the device is designed to protect against thermal overall conditions, this circuitry is not intended to replace proper heat sinking. Continuously running the device into thermal shutdown or above the maximum recommended junction temperature reduces long-term reliability.

7 Detailed Description

7.3 Feature Description (continued)

Built-in Output Current Limit

Each drive MOS of the H-bridge in CJDR8837 has a built-in current limiting mechanism. When it is detected that the current of any drive MOS exceeds the output current limit $I_{OUT\ Limit}$ in the data sheet and the duration exceeds the delay time T_D , all drive MOS will be closed. After the retry time T_R , the drive tube will automatically attempt to resume normal operation. At this time, if the output current still exceeds the rated range, the device will enter the current limit state again and turn off the output. Therefore, when the device enters the output current limit state because the output current exceeds the rated range, the device will continue the process of "Detection - Shutdown - Release - Detection" until the output current no longer exceeds its rated range. Typical values of output current limit $I_{OUT\ Limit}$, delay time T_D and retry time T_R can be found in *Electrical Characteristics*.

Short Circuit Protection

CJDR8837 has short circuit protection mechanism. When OUT x is short circuited to GND (for example, when the high side of OUT 1 is conductive, OUT 1 is abnormally short circuited to GND), or when OUT x is short circuited to V_M (for example, when the lower side of OUT 1 is conductive, OUT 1 is abnormally short circuited to V_M), the device will turn off the output of all drive MOS to protect the device from being burnt due to large current. The action mechanism of short-circuit protection is the same as that of current limit. See *Build-in Output Current Limit* for more details.

Under-voltage Locking

When the chip power supply voltage is lower than 1.9V (Typ.), the internal detection circuit will turn off the H-bridge output. If the voltage recovers, when the rising hysteresis voltage exceeds 1.8V (Typ.), the output turns on again.

Operation Mode

When IN 1 = IN 2 is low, CJDR8837 enters sleep mode. In sleep mode, all H-bridges are disconnected and output high resistance state. Most of the circuits of the chip circuit are turned off and enter the power saving mode. When IN 1 and IN 2 are not at low level at the same time, they will automatically resume normal operation.

Table 7-2. Operation Mode

MODE	CONDITION	H-BRIDGE
Work	nSleep = H	Normal
Sleep mode	nSleep = L	Off
Failure detection	Under-voltage protection	Shutdown
	Thermal shutdown	
	Current limit	Detection - Shutdown - Release - Detection
	Short circuit protection	

8 Application and Implementation

8.1 Typical Application Circuit

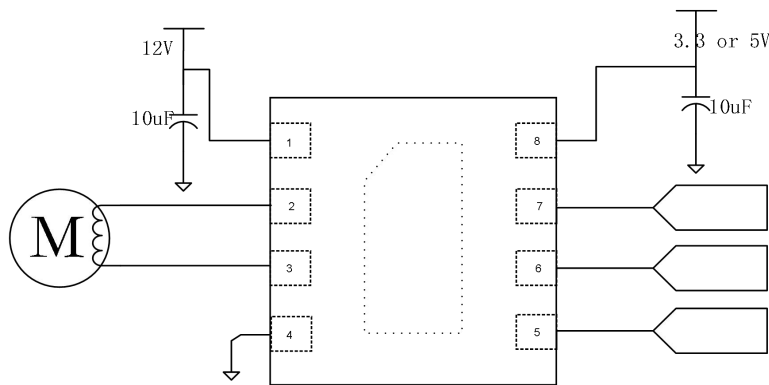

Figure 8-1. Driving DC Motor

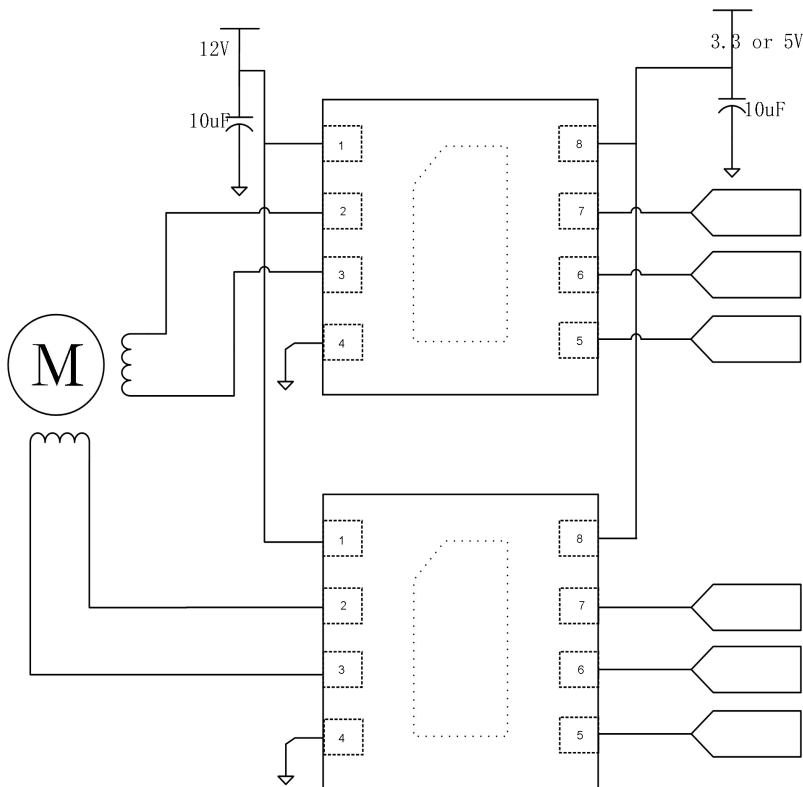

Figure 8-2. Driving Stepper Motor

8.2 Application Information

The bypass capacitor connection of V_{CC} and V_M should be as close as possible to the chip V_{CC} and V_M pin. When the load power supply exceeds 12V, it is recommended to increase the bypass capacitance of V_M to be greater than $56\mu F$. The ground wire connecting the motor needs to be isolated in layout design.

NOTE

The application information in this section is not part of the data sheet component specification, and JSCJ makes no commitment or statement to guarantee its accuracy or completeness. Customers are responsible for determining the rationality of corresponding components in their circuit design and making tests and verifications to ensure the normal realization of their circuit design.

9 Mechanical Information

DFNWB2x2-8L Mechanical Information

DFNWB2x2-8L Outline Dimensions (Unit: mm)

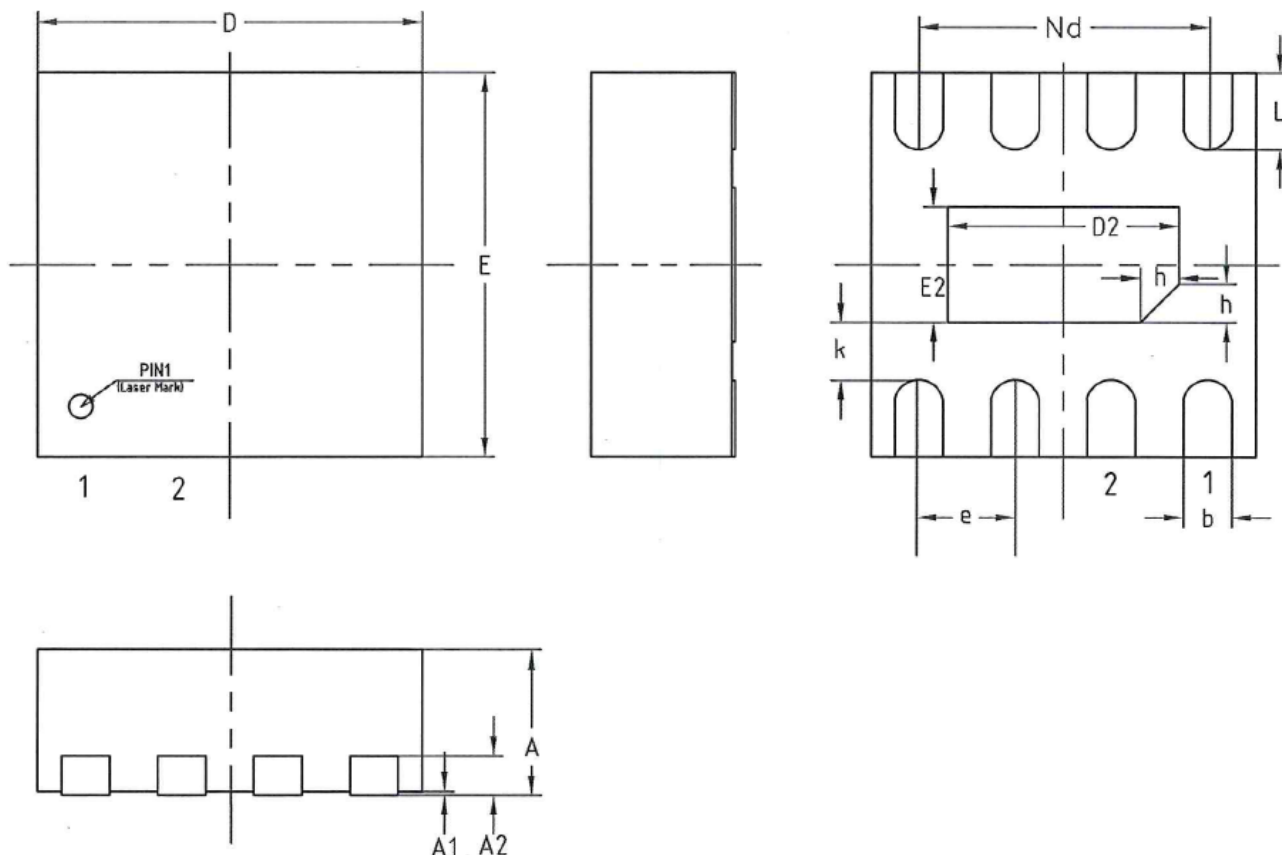

SYMBOL	DIMENSIONS IN MILLIMETERS			DIMENSIONS IN INCHES		
	MIN	NOM	MAX	MIN	NOM	MAX
A	0.700	0.750	0.800	0.028	0.030	0.031
A1	0.000	0.020	0.050	0.000	0.001	0.002
A2	0.203 REF			0.008 REF		
b	0.200	0.250	0.300	0.008	0.010	0.012
D	1.900	2.000	2.100	0.075	0.079	0.083
D2	1.100	1.200	1.300	0.043	0.047	0.051
E	1.900	2.000	2.100	0.075	0.079	0.083
E2	0.600	0.700	0.800	0.024	0.028	0.031
e	0.500 BSC			0.020 BSC		
K	0.250	0.300	0.350	0.010	0.012	0.014
L	0.300	0.350	0.400	0.012	0.014	0.016
h	0.150	0.200	0.250	0.006	0.008	0.010
Nd	1.500 BSC			0.059 BSC		

10 Notes and Revision History

10.1 Associated Product Family and Others

To view other products of the same type or IC products of other types, click the official website of JSCJ -- <https://www.jscj-elec.com> for more details.

10.2 Notes

Electrostatic Discharge Caution



This IC may be damaged by ESD. Relevant personnel shall comply with correct installation and use specifications to avoid ESD damage to the IC. If appropriate measures are not taken to prevent ESD damage, the hazards caused by ESD include but are not limited to degradation of integrated circuit performance or complete damage of integrated circuit. For some precision integrated circuits, a very small parameter change may cause the whole device to be inconsistent with its published specifications.

10.3 Revision History

June, 2023: changed from rev - 1.0 to rev - 1.1:

- Modified the mechanical data based on the actual packaging size.

August, 2022: released CJDR8837 rev - 1.0.

DISCLAIMER

IMPORTANT NOTICE, PLEASE READ CAREFULLY

The information in this data sheet is intended to describe the operation and characteristics of our products. JSCJ has the right to make any modification, enhancement, improvement, correction or other changes to any content in this data sheet, including but not limited to specification parameters, circuit design and application information, without prior notice.

Any person who purchases or uses JSCJ products for design shall: 1. Select products suitable for circuit application and design; 2. Design, verify and test the rationality of circuit design; 3. Procedures to ensure that the design complies with relevant laws and regulations and the requirements of such laws and regulations. JSCJ makes no warranty or representation as to the accuracy or completeness of the information contained in this data sheet and assumes no responsibility for the application or use of any of the products described in this data sheet.

Without the written consent of JSCJ, this product shall not be used in occasions requiring high quality or high reliability, including but not limited to the following occasions: medical equipment, military facilities and aerospace. JSCJ shall not be responsible for casualties or property losses caused by abnormal use or application of this product.

Official Website: www.jscj-elec.com

Copyright © JIANGSU CHANGJING ELECTRONICS TECHNOLOGY CO., LTD.