



SOT-523 Plastic-Encapsulate MOSFET

CJE3134KA N-Channel MOSFET

Key Performance Parameters

V _{BR(DSS)}	R _{DS(on)} TYP	I _D
20V	108mΩ@4.5V	1.3A
	129mΩ@2.5V	
	167mΩ@1.8V	

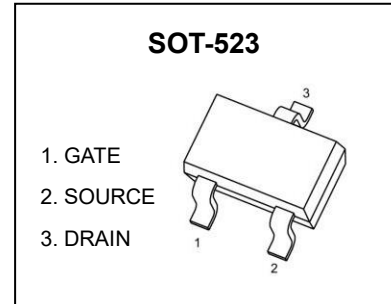

DESCRIPTION

This advanced technology has been especially tailored to minimize on-state resistance, provide superior switching performance.

FEATURES

- Battery switch
- Load switch
- High density cell design for ultra low R_{DS(ON)}

APPLICATIONS

- SMPS and general purpose applications
- Hard switched and high frequency circuits
- Uninterruptible Power Supply

MARKING



EQUIVALENT CIRCUIT

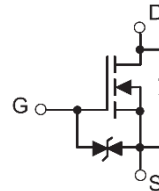

ABSOLUTE MAXIMUM RATINGS (T_A=25°C unless otherwise specified)

Parameter	Symbol	Value	Unit
Drain-Source Voltage	V _{DS}	20	V
Gate-Source Voltage	V _{GS}	±10	V
Continuous Drain Current	I _D ⑤	T _A =25°C	1.3
		T _A =75°C	1.0
Pulsed Drain Current	I _{DM} ①②	5.2	A
Power Dissipation	P _D ①⑤	0.38	W
Operating Junction and Storage Temperature Range	T _J , T _{stg}	-55~+150	°C

Thermal Characteristics

Parameter	Symbol	Value		Unit
		Typ	Max	
Thermal Resistance from Junction to Ambient	R _{θJA} ⑤	t≤10s	333	°C/W
		Steady State	380	°C/W

Typical Characteristics

ELECTRICAL CHARACTERISTICS (T_J=25°C unless otherwise specified)

Static Characteristics

Parameter	Symbol	Test Condition	Value			Unit	
			Min	Typ	Max		
Drain-source breakdown voltage	V _{(BR)DSS}	V _{GS} = 0V, I _D = 250μA	20	-	-	V	
Zero gate voltage drain current	I _{DSS}	V _{DS} = 20V, V _{GS} = 0V	T _J = 25°C	-	-	1.0	μA
			T _J = 125°C	-	-	100	
Gate-body leakage current	I _{GSS}	V _{GS} = ±10V, V _{DS} = 0V	-	-	±20	μA	
Gate-threshold voltage	V _{GS(th)}	V _{DS} = V _{GS} , I _D = 250μA	0.4	0.7	1.1	V	
Static drain-source on-state resistance	R _{DS(on)} ^③	V _{GS} = 4.5V, I _D = 0.65A	T _J = 25°C	-	108	150	mΩ
			T _J = 125°C	-	151	210	
		V _{GS} = 2.5V, I _D = 0.55A	-	129	190		
		V _{GS} = 1.8V, I _D = 0.45A	-	167	260		
Forward transconductance	g _{FS}	V _{DS} = 10V, I _D = 0.8A	-	1.73	-	S	

Dynamic Characteristics^④

Input capacitance	C _{iss}	V _{GS} = 0V, V _{DS} = 16V, f = 1MHz	-	52	-	pF
Output capacitance	C _{oss}		-	19	-	
Reverse transfer capacitance	C _{rss}		-	10	-	
Total gate charge	Q _g	V _{GS} = 2.5V, V _{DS} = 10V, I _D = 1A	-	0.532	-	nC
Total gate charge	Q _g	V _{GS} = 4.5V, V _{DS} = 10V, I _D = 1A	-	0.83	-	
Gate charge at threshold	Q _{G(th)}		-	0.085	-	
Gate-source charge	Q _{gs}		-	0.17	-	
Gate-drain charge	Q _{gd}		-	0.14	-	
Turn-on delay time	t _{d(on)}	V _{DD} = 10V, V _{GS} = 4.5V, I _D = 0.5A, R _g = 10Ω	-	6.6	-	ns
Turn-on rise time	t _r		-	15.2	-	
Turn-off delay time	t _{d(off)}		-	103	-	
Turn-off fall time	t _f		-	59	-	

Reverse Diode Characteristics

Drain-source diode forward voltage	V _{SD} ^③	V _{GS} = 0V, I _S = 0.15A	-	-	1.2	V
Continuous drain-source diode forward current	I _S ^①		-	-	1.3	A
Pulsed drain-source diode forward current	I _{SM} ^{①②}		-	-	5.2	A

Notes:

- ①. Limited only by maximum temperature allowed.
- ②. P_w ≤ 10μs, Duty cycle ≤ 1%.
- ③. Pulse Test : Pulse Width ≤ 380μs, duty cycle ≤ 2%.
- ④. Guaranteed by design, not subject to production.
- ⑤. Device mounted on 1 in² FR-4 board with 2oz. double-sided Copper, in a still air environment with T_A = 25°C. The current rating is based on the t ≤ 10s thermal resistance rating.

Typical Characteristics

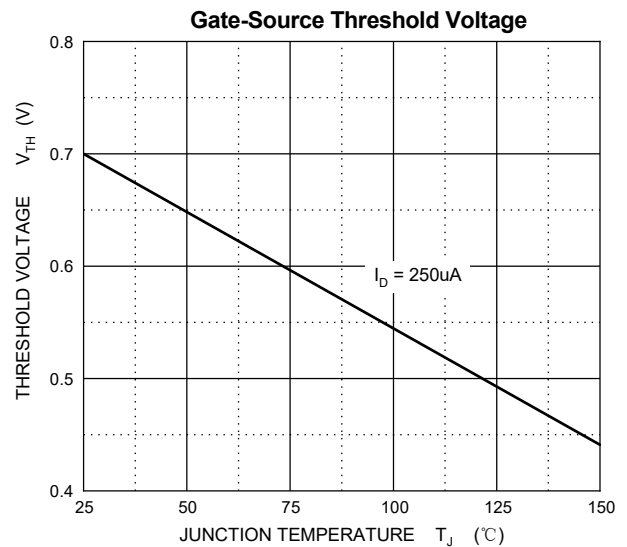
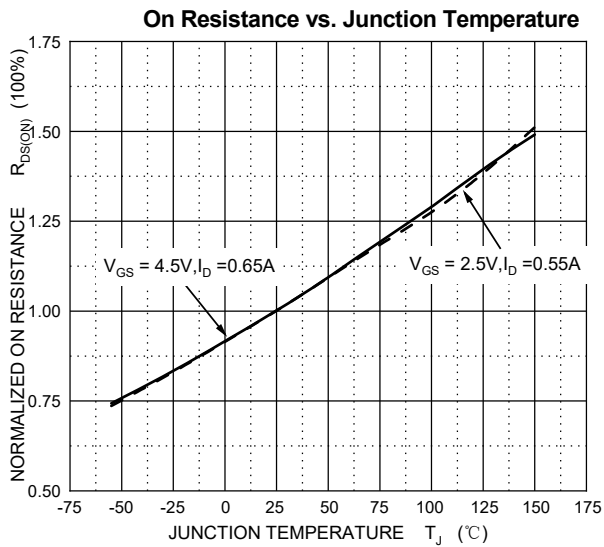
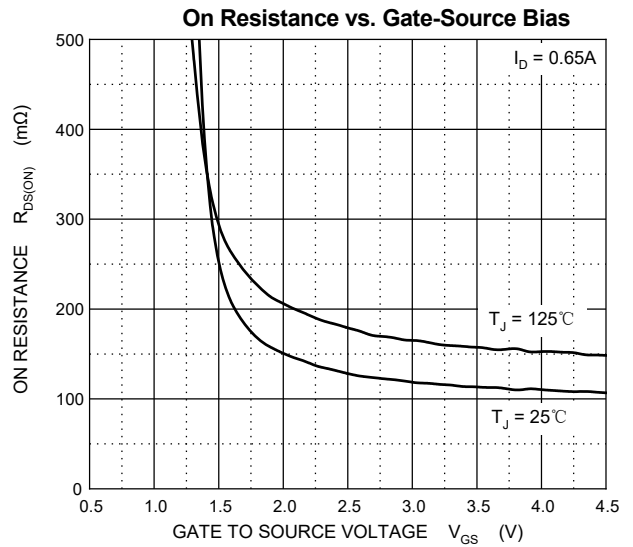
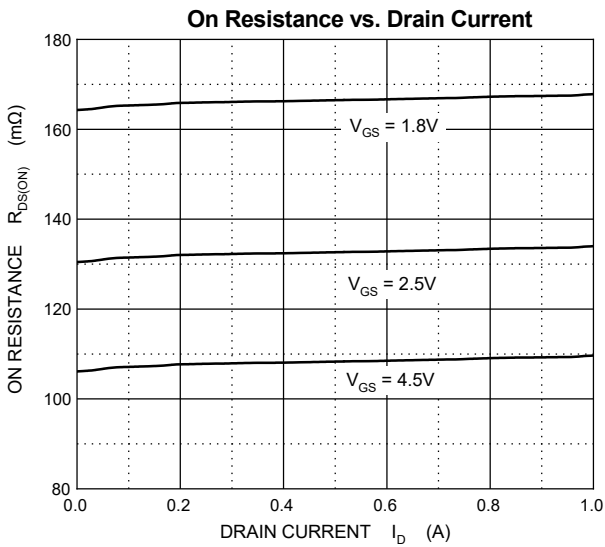
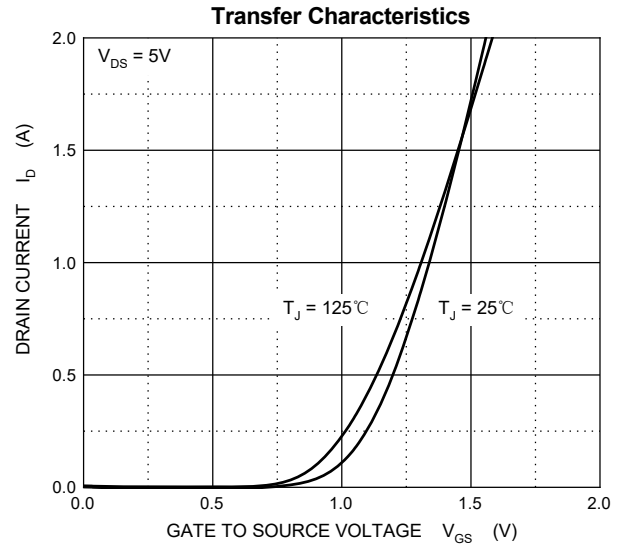
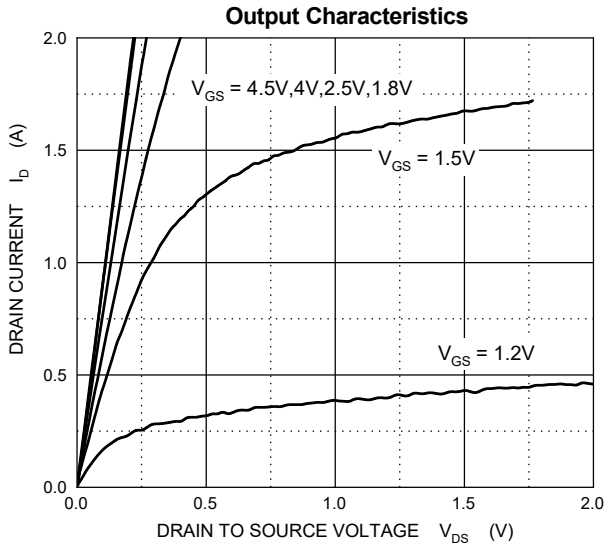

Typical Characteristics

Typical Capacitances

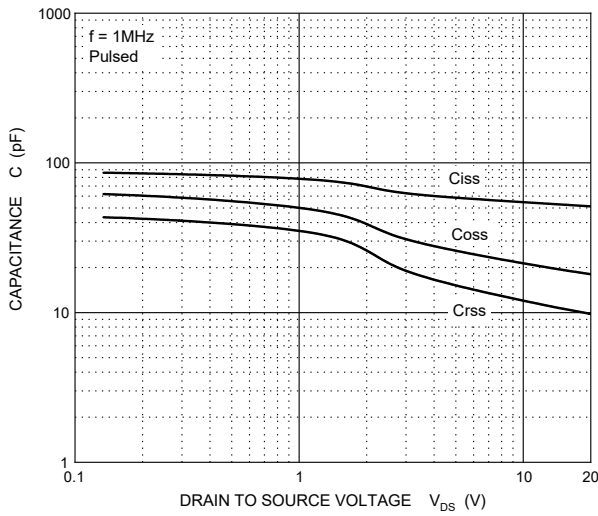

Gate Charge

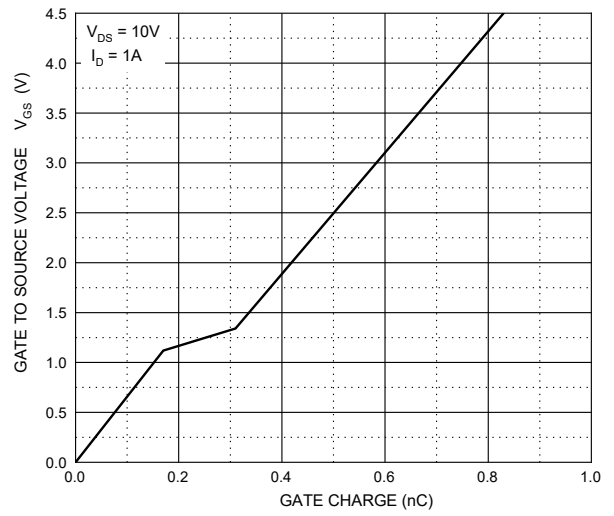

Source-Drain Diode Forward Characteristics

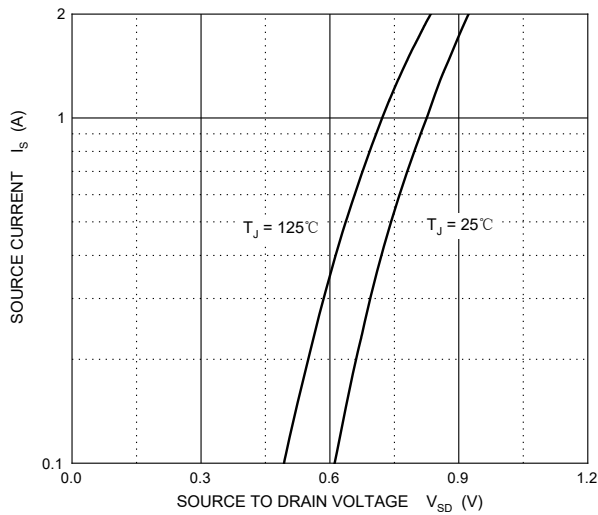

Drain-Source Breakdown Voltage

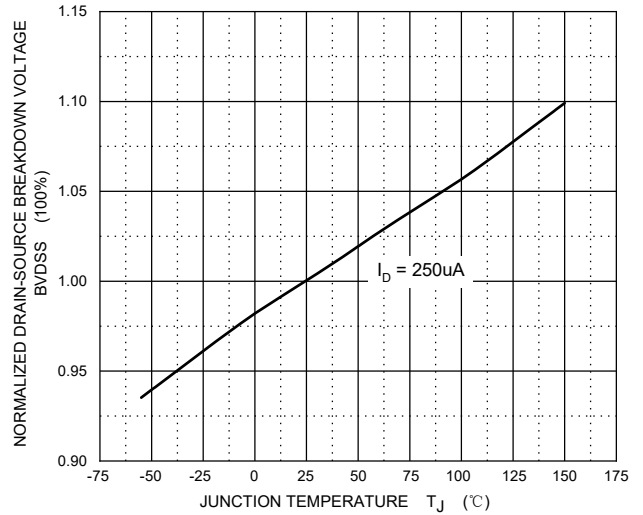

Maximum Safe Operating Area

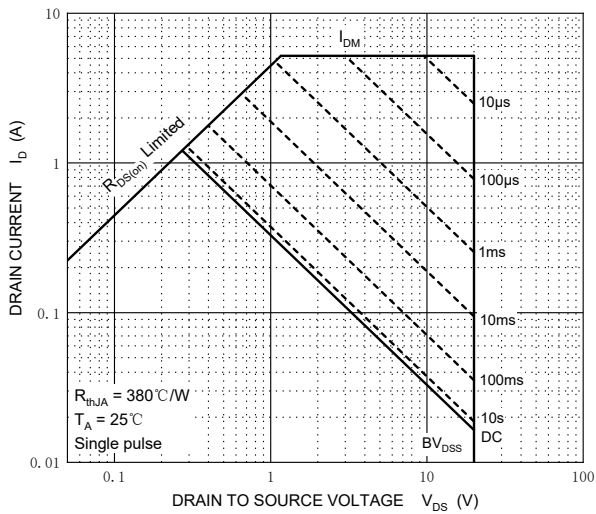

Typical Characteristics

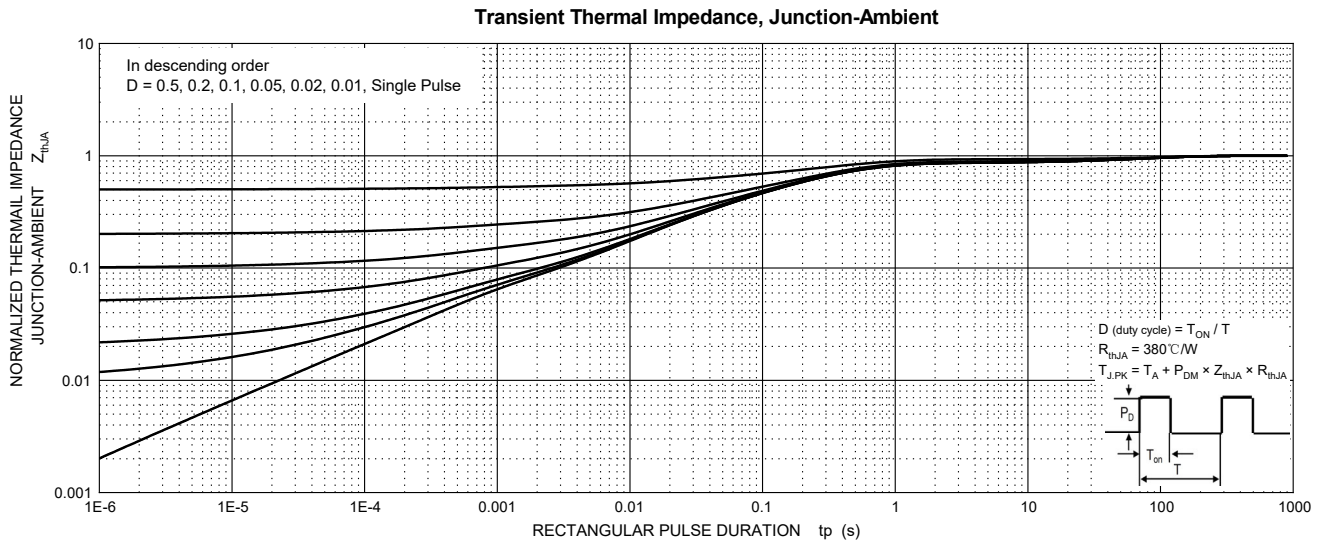

SOT-523 Package Outline Dimensions

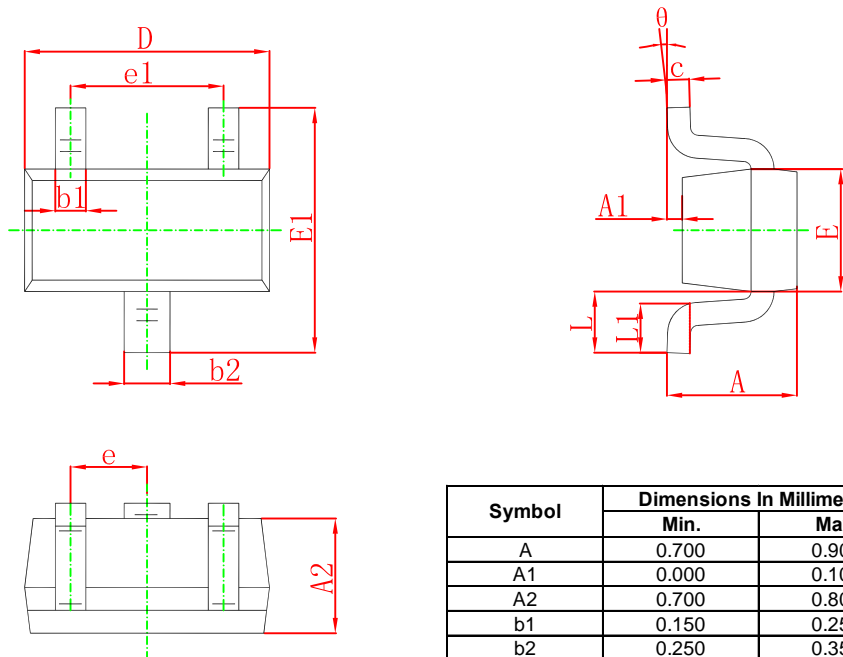

Symbol	Dimensions In Millimeters		Dimensions In Inches	
	Min.	Max.	Min.	Max.
A	0.700	0.900	0.028	0.035
A1	0.000	0.100	0.000	0.004
A2	0.700	0.800	0.028	0.031
b1	0.150	0.250	0.006	0.010
b2	0.250	0.350	0.010	0.014
c	0.100	0.200	0.004	0.008
D	1.500	1.700	0.059	0.067
E	0.700	0.900	0.028	0.035
E1	1.450	1.750	0.057	0.069
e	0.500 TYP.		0.020 TYP.	
e1	0.900	1.100	0.035	0.043
L	0.400 REF.		0.016 REF.	
L1	0.260	0.460	0.010	0.018
θ	0°	8°	0°	8°

SOT-523 Suggested Pad Layout

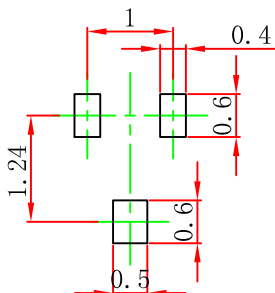

- Note:
1. Controlling dimension: in millimeters.
 2. General tolerance: ± 0.05 mm.
 3. The pad layout is for reference purposes only.

NOTICE

JSCJ reserves the right to make modifications, enhancements, improvements, corrections or other changes without further notice to any product herein. JSCJ does not assume any liability arising out of the application or use of any product described herein.

SOT-523 Tape and Reel

SOT-523 Embossed Carrier Tape

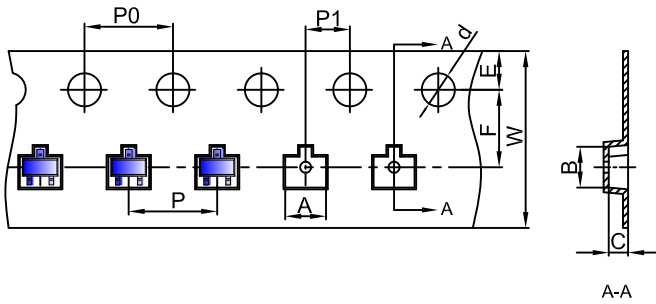

Packaging Description:

SOT-523 parts are shipped in tape. The carrier tape is made from a dissipative (carbon filled) polycarbonate resin. The cover tape is a multilayer film (Heat Activated Adhesive in nature) primarily composed of polyester film, adhesive layer, sealant, and anti-static sprayed agent. These reeled parts in standard option are shipped with 3,000 units per 7" or 17.8cm diameter reel. The reels are clear in color and is made of polystyrene plastic (anti-static coated).

Dimensions are in millimeter										
Pkg type	A	B	C	d	E	F	P0	P	P1	W
SOT-523	1.85	1.85	0.875	Ø1.50	1.75	3.50	4.00	4.00	2.00	8.00

SOT-523 Tape Leader and Trailer

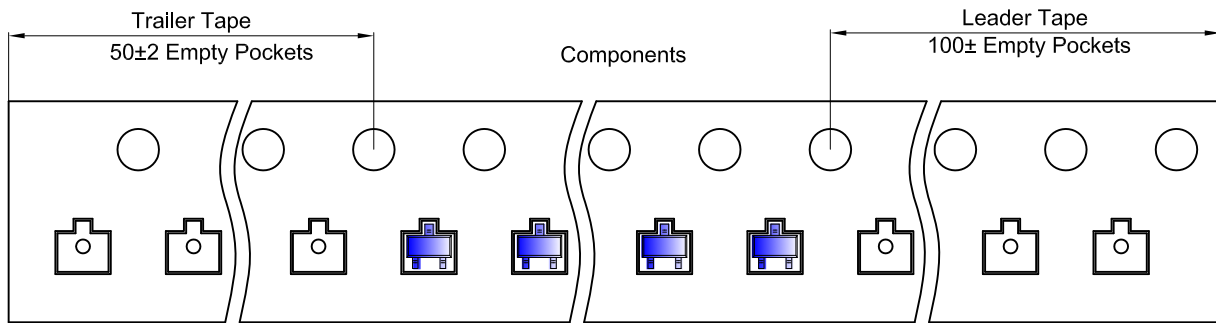

SOT-523 Reel

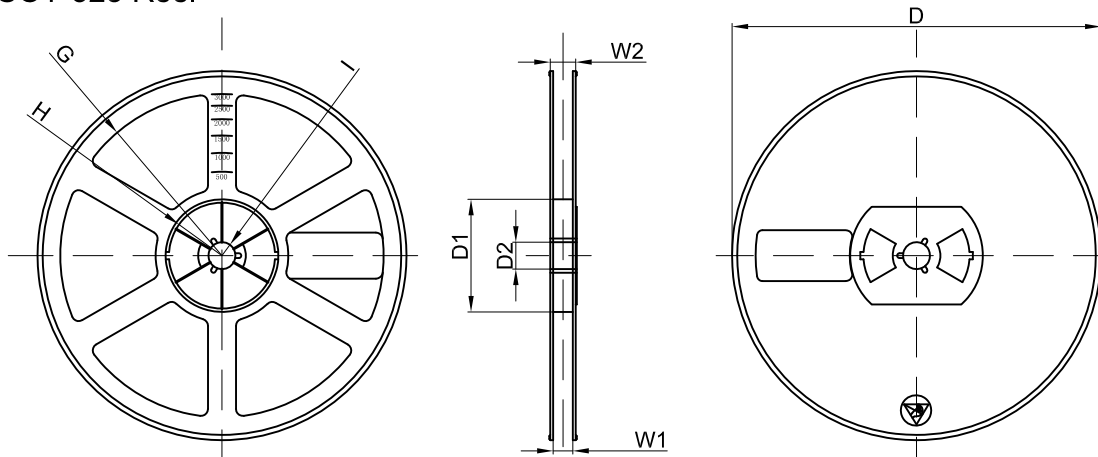

Dimensions are in millimeter								
Reel Option	D	D1	D2	G	H	I	W1	W2
7" Dia	Ø178.00	54.40	13.00	R78.00	R25.60	R6.50	9.50	12.30

REEL	Reel Size	Box	Box Size(mm)	Carton	Carton Size(mm)	G.W.(kg)
3000 pcs	7 inch	45,000 pcs	203×203×195	180,000 pcs	438×438×220	