



## CJLS2101 Series Power Distribution Switches

### 1 Introduction

The CJLS2101 series power-distribution switches are intended for applications where precision current limiting is required or heavy capacitive loads and short circuits are encountered. The CJLS2101DH offers a programmable current limit threshold between 200mA to 3A via an external resistor. The power-switch rise and fall times are controlled to minimize current surges during turn-on and turn-off. Devices limit the output current to a safe level by using a constant current mode when the output load exceeds the current-limit threshold. An internal reverse-voltage comparator disables the power-switch when the output voltage is driven higher than the input. The nFLG output asserts low during over-current and reverse-voltage conditions.

### 2 Available Packages

PARTNUMBER	PACKAGE
CJLS2101 Series	SOT-23-5L

**Note:** For all available packages, please refer to the part *Orderable Information*.

### 3 Features

- Integrated 55mΩ (Typical) Power MOSFET
- Current Limit:  
Adjustable 200mA~3A (Typical)
- Fast Transient Response: 9.4us (Typical)
- Input Voltage Range: 2.5V~5.5V
- 0.13ms Typical Rise Time
- Reverse Input-Output Voltage Protection
- Thermal Shutdown Protection
- Built-In Soft Start
- Automatic Output Discharge at Shutdown
- Deglitched Open-Drain Over-Current Flag (CJLS2101AH/BH/CH)
- Constant Current (CJLS2101 AH/BH/CH) and Adjustable Current (CJLS2101DH) Versions

### 4 Applications

- USB Bus/Self Powered Hubs
- Battery-Charger Circuits
- Set-Top Boxes
- Personal Communication Devices
- Portable Audio Video Equipment

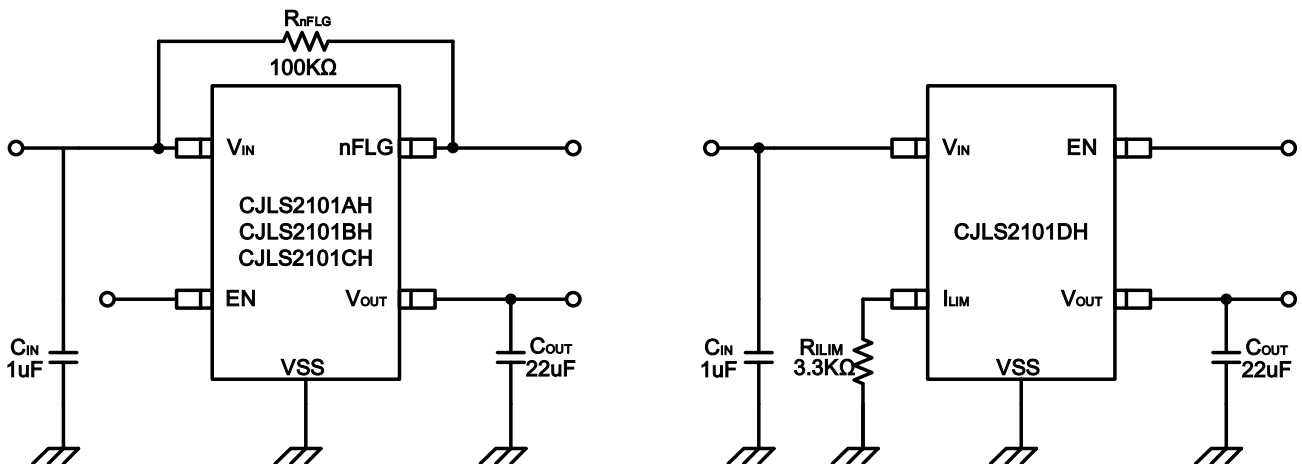

Typical Application Circuit

## 5 Pin Configuration and Marking Information

### 5.1 Pin Configuration and Function

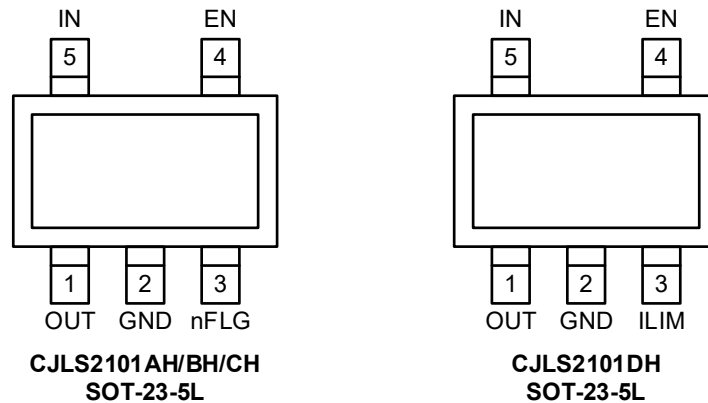

PIN NAME	I/O	CJLS2101Series Pin Function
		DESCRIPTION
OUT	O	Power-switch output.
GND	-	Ground.
EN	I	Enable input, logic high turns on power switch.
IN	I	Input voltage; connect a 0.1 $\mu$ F or greater ceramic capacitor from IN to GND as close to the IC as possible.
nFLG	O	Active-low open-drain output, asserted during over-current, over-temperature, or reverse-voltage conditions
ILIM	O	External resistor used to set current-limit threshold

### 5.2 Marking Information

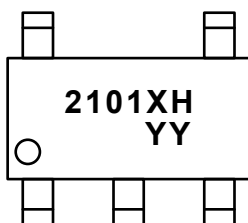

"**2101XH**": Device number. For example, for CJLS2101AH, the content is 2101AH.

"**YY**": Code, indicates weekly record information.

## 6 Specifications

### 6.1 Absolute Maximum Ratings

( $T_A = 25^\circ\text{C}$ , unless otherwise specified)<sup>(1)</sup>

CHARACTERISTIC			SYMBOL	VALUE	UNIT
Input voltage range <sup>(2)</sup>			$V_{IN}$	-0.3 ~ 6.0	V
Output voltage range <sup>(2)</sup>			$V_{OUT}$	$V_{SS}-0.3 \sim V_{IN} + 0.3 \leq 6$	V
Enable, nFLG, ILIM input voltage range <sup>(2)</sup>			$V_{EN}, V_{nFLG}, V_{ILIM}$	$V_{SS}-0.3 \sim V_{IN} + 0.3$	V
Work temperature			$T_{op}$	-40 ~ +125	°C
Maximum power dissipation	CJLS2101 Series	SOT-23-5L	$P_{D \text{ Max}}$	Internally Limited <sup>(3)</sup>	W
Maximum junction temperature			$T_J$	150	°C
Storage temperature			$T_{STG}$	-40 ~ +150	°C
Soldering temperature & time			$T_{solder}$	260°C, 10s	-

(1) Stresses beyond those listed under Absolute Maximum Ratings may cause permanent damage to the device. These are stress ratings only, which do not imply functional operation of the device at these or any other conditions beyond those indicated under Recommended Operating Conditions. Exposure to absolute maximum rated conditions for extended periods may affect device reliability.

(2) All voltages are with respect to network ground terminal.

(3) Refer to Thermal Information for details.

### 6.2 Recommended Operating Conditions

PARAMETER	SYMBOL	MIN.	NOM.	MAX.	UNIT
Input voltage	$V_{IN}$	2.5	-	5.5	V
Operating junction temperature	$T_J$	-40	-	125	°C
Operating ambient temperature	$T_A$	-40	-	85	°C

### 6.3 ESD Ratings

ESD RATINGS		SYMBOL	VALUE	UNIT
Electrostatic discharge <sup>(4)</sup>	Human body model	$V_{ESD-HBM}$	2000	V

(4) ESD testing is conducted in accordance with the relevant specifications formulated by the Joint Electronic Equipment Engineering Commission (JEDEC). The human body model (HBM) electrostatic discharge test is based on the JS-001-2023 test standard, using a 100pF capacitor and discharging to each pin of the device through a resistance of 1.5kΩ.

**6 Specifications**
**6.4 Thermal Information**

THERMAL METRIC <sup>(5)</sup>	SYMBOL	CJLS2101 Series	UNIT
Junction-to-ambient thermal resistance	$R_{\theta JA}$	SOT-23-5L	°C/W
		249.5	
Junction-to-case thermal resistance	$R_{\theta JC}$	SOT-23-5L	°C/W
		249.5	
Reference maximum power dissipation for continuous operation	$P_{D Ref}$	SOT-23-5L	W
		249.5	

(5) Thermal metric is measured in still air with  $T_A = 25^\circ\text{C}$  and mounted on a 1 in<sup>2</sup> FR-4 substrate PCB covered with 2 ounces of copper.

## 6 Specifications

### 6.5 Electrical Characteristics

CJLS2101 Series ( $V_{IN} = 5V$ ,  $C_{IN} = 1\mu F$ ,  $C_L = 1\mu F$ ,  $T_A = 25^\circ C$ , unless otherwise specified)

SYMBOL	PARAMETER	CONDITION	MIN	TYP	MAX	UNIT	
$V_{IN}$	Input voltage	-	2.5	-	5.5	V	
$r_{DS\_on}$	-	$I_{LOAD} = 1A$	-	55	-	m $\Omega$	
$t_r$	Rise time	$C_L = 1\mu F$ , $R_L = 100\Omega$ (see Figure 8-1)	$V_{IN} = 5.5V$	-	134	500	$\mu s$
			$V_{IN} = 2.5V$	-	87	400	
$t_f$	Fall time	$C_L = 1\mu F$ , $R_L = 100\Omega$ (see Figure 8-1)	$V_{IN} = 5.5V$	-	182	500	
			$V_{IN} = 2.5V$	-	186	500	
<b>Enable input</b>							
$V_{EN\_H}$	En rise threshold	$V_{IN} = 5.5V$	0.6	0.75	1.2	V	
		$V_{IN} = 2.5V$	0.5	0.78	1.0		
$V_{EN\_HY}$	EN hysteresis	$V_{IN} = 5.5V$	-	0.15	-		
		$V_{IN} = 2.5V$	-	0.17	-		
$I_{EN}$	En input current	$V_{EN} = 5V$	-	0.02	1.0	$\mu A$	
$T_{on}$	Turn on time	$C_L = 1\mu F$ , $R_L = 100\Omega$ (see Figure 8-1)	$V_{IN} = 5.5V$	-	215	-	$\mu s$
			$V_{IN} = 2.5V$	-	187	-	
$T_{off}$	Turn off time	$C_L = 1\mu F$ , $R_L = 100\Omega$ (see Figure 8-1)	$V_{IN} = 5.5V$	-	185	-	
			$V_{IN} = 2.5V$	-	189	-	
<b>Current limit</b>							
$I_{LIM}$	Limit current	$R_{LIM}=6.8K\Omega$ (CJLS2101DH)	0.9	1.0	1.1	A	
		CJLS2101AH	0.5	0.6	0.7		
		CJLS2101BH	1.8	2.0	2.2		
		CJLS2101CH	2.4	2.7	3.0		
$T_{IOS}$	Short circuit response time	$V_{IN} = 5V$ , $C_L = 22\mu F$ (see Figure 8-2)	-	9.4	-	$\mu s$	
<b>Reverse-voltage protection</b>							
$V_{REVERSE\_UP}$	$V_{OUT}-V_{IN}$	-	-	130	400	mV	
$V_{REVERSE\_DOWN}$	$V_{OUT}-V_{IN}$	-	-	17	300	mV	
<b>Supply current</b>							
$I_{IN\_OFF}$	Supply current	$V_{IN} = 5V$ , $V_{EN} = GND$	-	0.15	1.0	$\mu A$	
$I_{IN\_ON}$	Supply current	$V_{IN} = 5V$ , $V_{EN} = 5V$	-	20	50	$\mu A$	
$I_{REV}$	Reverse leakage current	$V_{IN} = 0$ , $V_{OUT} = 5V$	-	1.0	5.0	$\mu A$	
<b>Under voltage lockout</b>							
$V_{UVLO}$	UVLO threshold	-	-	2.1	2.4	V	
$V_{UVLO\_HY}$	UVLO hysteresis	-	-	0.25	0.5	V	

**6 Specifications**
**6.5 Electrical Characteristics**
**CJLS2101 Series ( $V_{IN} = 5V$ ,  $C_{IN} = 1\mu F$ ,  $C_L = 1\mu F$ ,  $T_A = 25^\circ C$ , unless otherwise specified)**

SYMBOL	PARAMETER	CONDITION	MIN	TYP	MAX	UNIT
<b>nFLG</b>						
$V_{OL}$	Output low voltage	$I_{FLG} = 1mA$	-	5.0	180	mV
$I_{FLG\_LEAK}$	Off-state leakage	$V_{nFLG} = 5.5V$	-	0.01	1.0	$\mu A$
$T_{FLG}$	nFLG flag deglitch time	$T_{FLG}$ due to over-current	-	5.0	-	ms
		$T_{FLG}$ due to reverse voltage	-	2.1	-	
<b>Thermal shutdown</b>						
$T_{OTP}$	Thermal shutdown threshold	-	-	145	-	$^\circ C$
$T_{OTP\_HY}$	Thermal shutdown hysteresis	-	-	20	-	

## 6 Specifications

### 6.6 Typical Characteristics

CJLS2101 Series ( $V_{IN} = 5$ ,  $C_{IN} = 1\mu F$ ,  $C_{OUT} = 22\mu F$ ,  $T_A = 25^\circ C$ , unless otherwise specified)

Turn-on Delay and Rise Time

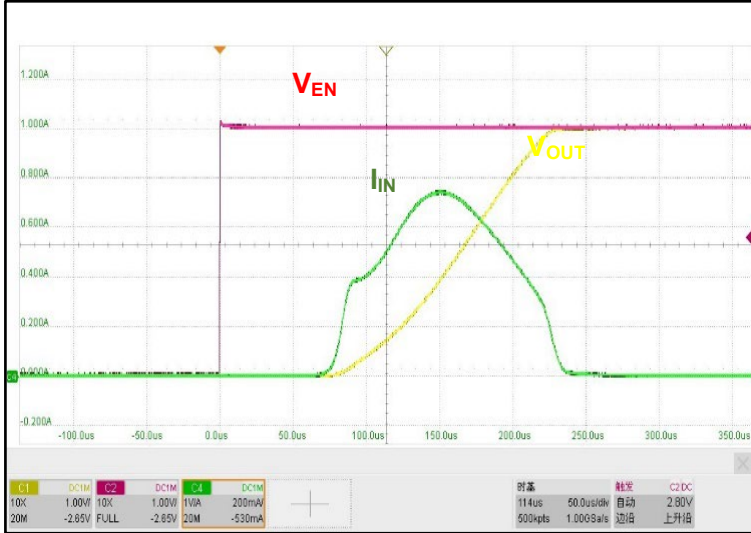

Turn-off Delay and Fall Time

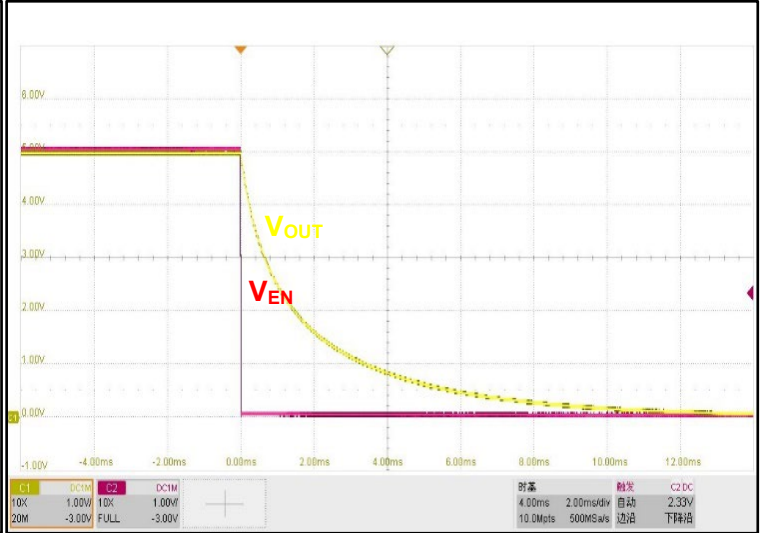

Device Enable into Short-Circuit

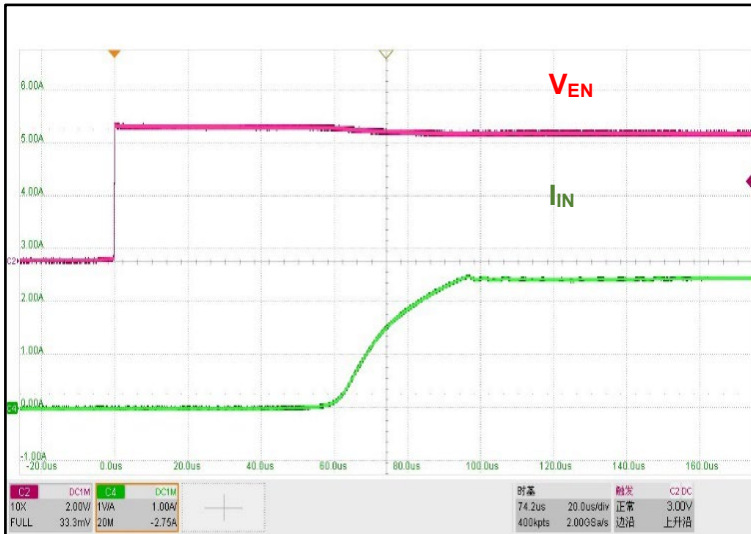

Full-Load into Short-Circuit Transient Response

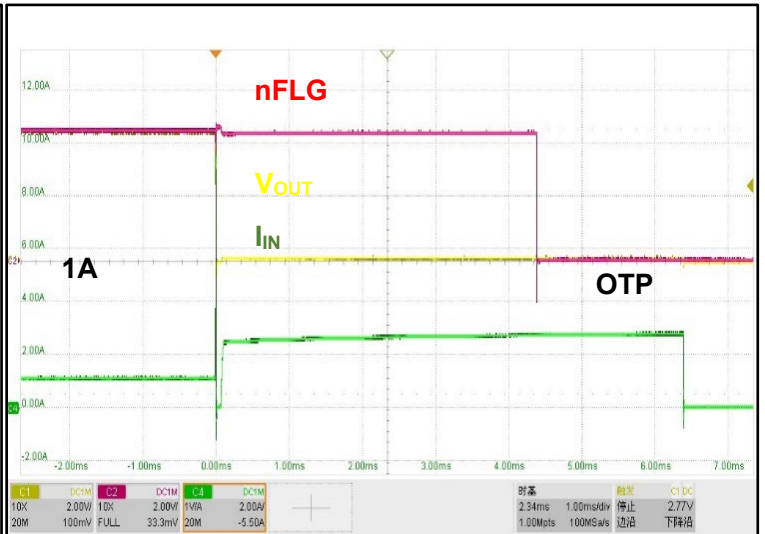

Short-Circuit into Full-Load Recovery Response

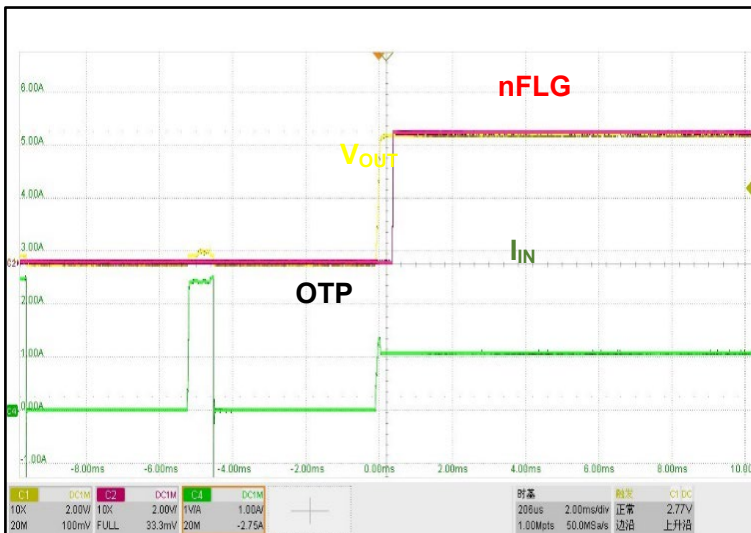

No-Load into Short-Circuit Transient Response

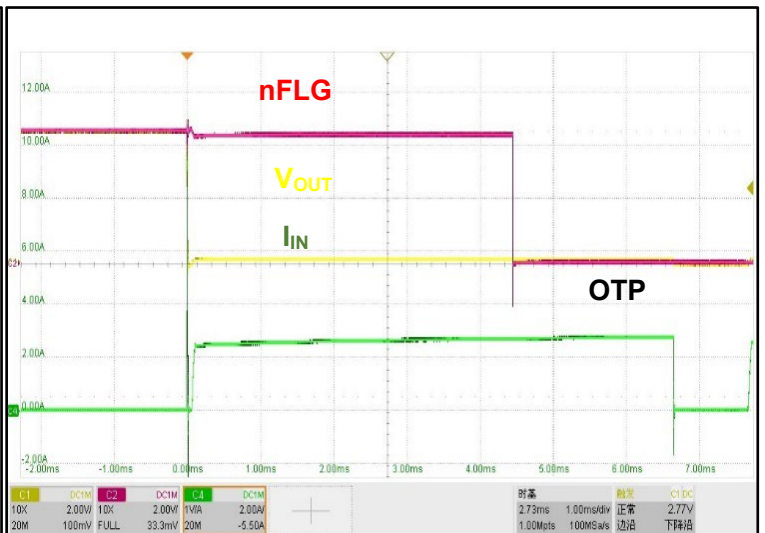

6 Specifications

6.6 Typical Characteristics (continued)

CJLS2101 Series ( $V_{IN} = 5V$ ,  $C_{IN} = 1\mu F$ ,  $C_{OUT} = 22\mu F$ ,  $T_A = 25^\circ C$ , unless otherwise specified)

Short-Circuit to No-Load Recovery Response



No-Load to Current Limit Transient Response

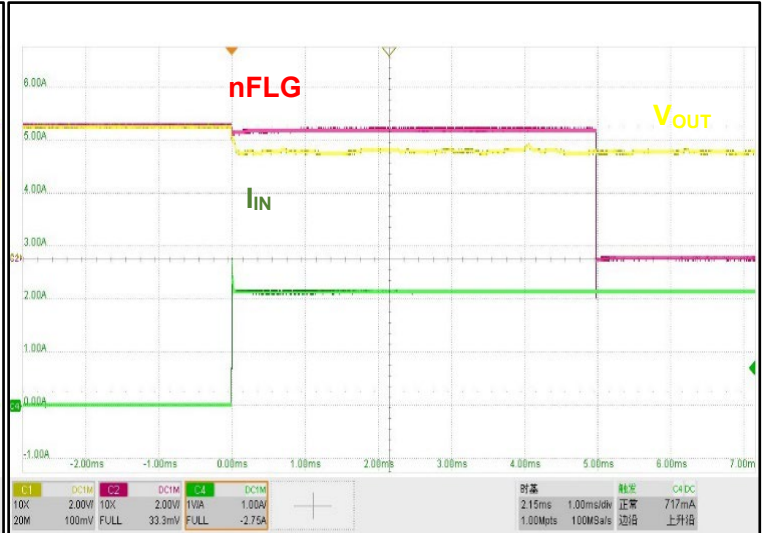

Current Limit to No-Load Transient Response

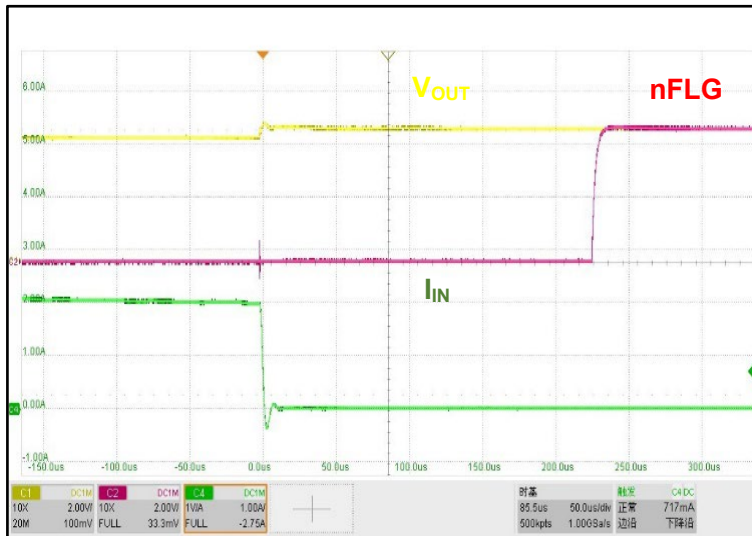

Reverse-Voltage Protection Response

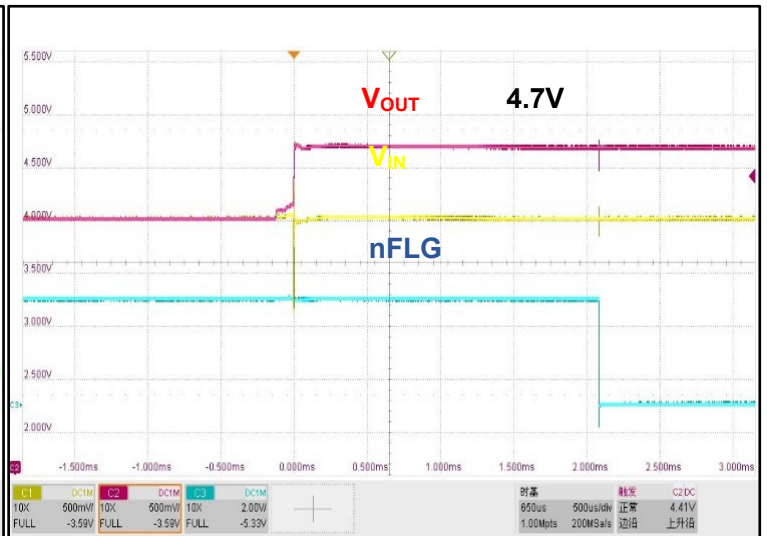

Reverse-Voltage Protection Recovery

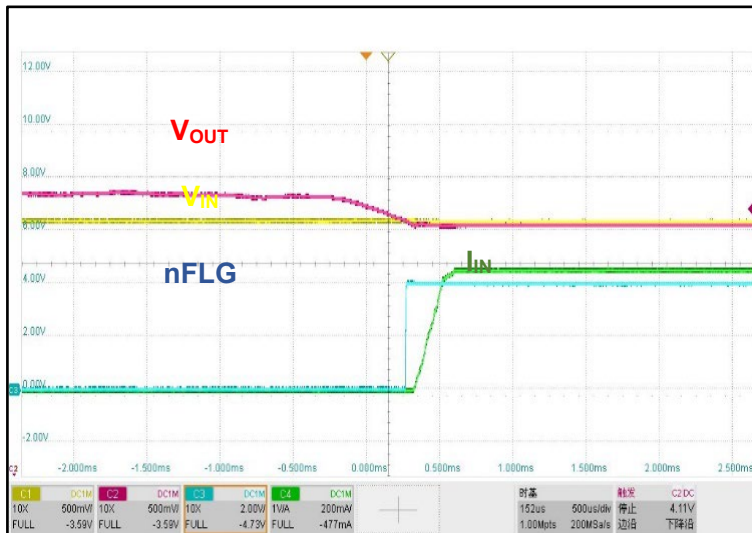

OTP Due to Short-Circuit

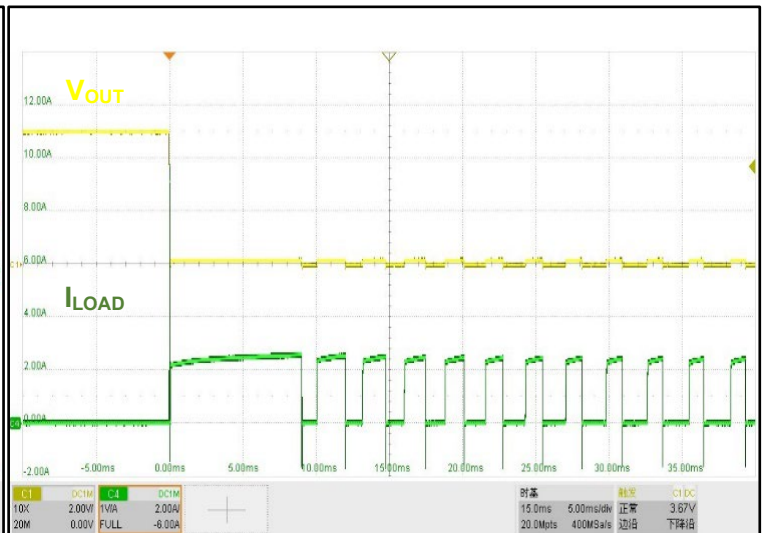

7 Parameter Measurement Information

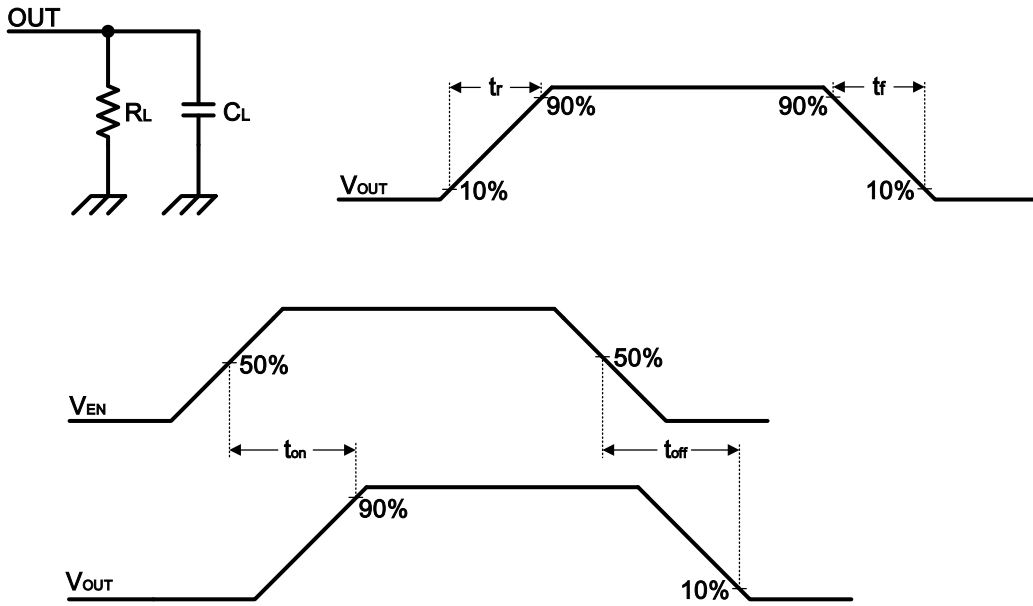

Figure 8-1. Test circuit and Voltage Waveforms

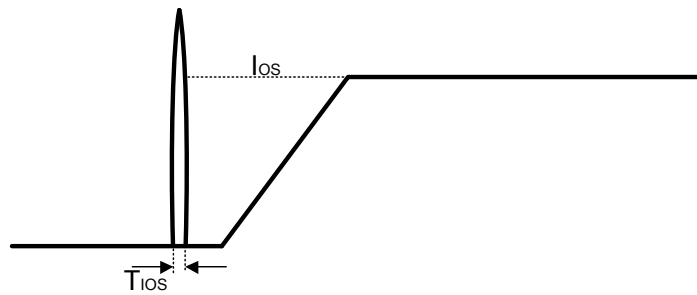

Figure 8-2. Response Time to Short Circuit Waveform

## 8 Detailed Description

### 8.1 Description

The CJLS2101 series are current-limited, power-distribution switches using P-channel MOSFETs for applications where short circuits or heavy capacitive loads are encountered. The CJLS2101DH offers a programmable current limit threshold between 200mA to 3A (typical) via an external resistor. Additional device shutdown features include over-temperature protection and reverse-voltage protection. The driver controls the gate voltage of the power switch. The driver incorporates circuitry that controls the rise and fall times of the output voltage to limit large current and voltage surges and provides built-in soft-start functionality. The CJLS2101AH/BH/CH are constant current versions, and the CJLS2101DH is a programmable current version.

### 8.2 Function Block Diagram

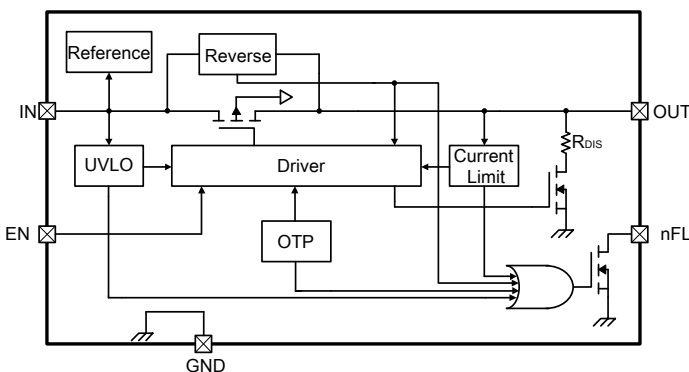

Figure 8-1. CJLS2101AH/BH/CH Block Diagram

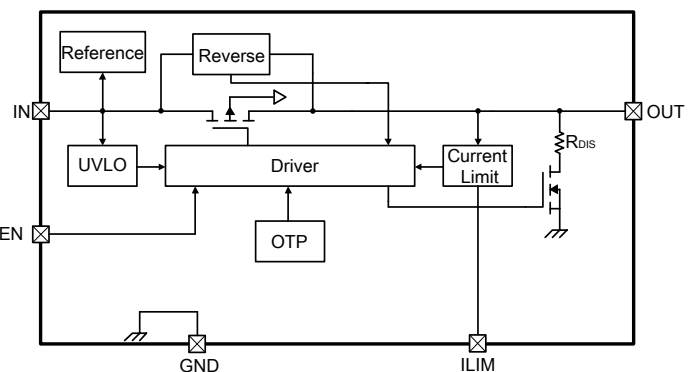

Figure 8-2. CJLS2101DH Block Diagram

### 8.3 Feature Description

#### Current Limit

The over-current threshold is user programmable via an external resistor. The CJLS2101DH use an internal regulation loop to provide a regulated voltage on the  $I_{LIM}$  pin. The current-limit threshold is proportional to the current sourced out of  $I_{LIM}$ . The recommended 1% resistor range for  $R_{ILIM}$  is  $2.2k\Omega \leq R_{ILIM} \leq 34k\Omega$  to ensure stability of the internal regulation loop.

#### Reverse-Voltage Protection

The reverse-voltage protection feature turns off the P-channel MOSFET whenever the output voltage exceeds the input voltage by 130mV (typical). A reverse current of  $(V_{OUT}-V_{IN}) / r_{DS(on)}$  are present when this occurs. This prevents damage to devices on the input side of the CJLS2101 by preventing significant current from sinking into the input capacitance. The reverse-voltage comparator asserts the nFLG output (active-low) after 2.1 ms(typical).

#### nFLG Response

The nFLG open-drain output is asserted (active low) during an over-current, over-temperature or reverse-voltage condition. The CJLS2101AH/BH/CH asserts the nFLG signal until the nFLG condition is removed and the device resumes normal operation. The nFLG signal is de-asserted once device power is cycled or the enable is toggled and the device resumes normal operation. The CJLS2101AH/BH/CH is designed to eliminate false nFLG reporting by using an internal delay de-glitch circuit for over-current (5ms typical) and reverse-voltage (2.1ms typical) conditions without the need for external circuitry. This ensures that nFLG is not accidentally asserted due to normal operation such as starting into a heavy capacitive load.

## 8 Detailed Description

### 8.3 Feature Description (continued)

#### Undervoltage Lockout (UVLO)

The undervoltage lockout (UVLO) circuit disables the power switch until the input voltage reaches the UVLO turn on threshold. Built-in hysteresis prevents unwanted on and off cycling due to input voltage drop from large current surges.

#### Enable

The logic enable controls the power switch, driver, and other circuits to reduce the supply current. The supply current is reduced to less than 1µA when a logic low is present on EN. A logic high input on EN enables the driver, control circuits, and power switch.

#### Thermal Sense

The CJLS2101 has self-protection features using thermal-sensing circuits that monitor the operating temperature of the power switch and disable operation if the temperature exceeds recommended operating conditions. The CJLS2101 operates in constant-current mode during an over-current condition, which increases the voltage drop across power-switch. The power dissipation in the package is proportional to the voltage drop across the power switch, which increases the junction temperature during an over-current condition. The thermal sensor turns off the power switch when the die temperature exceeds 145°C (typical). Hysteresis is built into the thermal sensor, and the switch turns on after the device has cooled approximately 20°C (typical).

#### Layout Consideration

For best performance of the CJLS2101, the following guidelines must be strictly followed.

- 1) Input and output capacitors should be placed close to the IC and connected to ground plane to reduce noise coupling.
- 2) The GND should be connected to a strong ground plane for heat sink.
- 3) Keep the main current traces as possible as short and wide.

#### Programming the Current-Limit Threshold

The over-current threshold is user programmable through an external resistor. The CJLS2101DH use an internal regulation loop to provide a regulated voltage on the I<sub>LIM</sub> pin. The current-limit threshold is proportional to the current sourced out of I<sub>LIM</sub>. The recommended 1% resistor range for R<sub>LIM</sub> is 2.2kΩ ≤ R<sub>LIM</sub> ≤ 34kΩ to ensure stability of the internal regulation loop. Many applications require that the minimum current limit is above a certain current level or that the maximum current limit is below a certain current level, so it is important to consider the tolerance of the over-current threshold when selecting a value for R<sub>LIM</sub>. The following equations and Figure 10-1 can be used to calculate the resulting over-current threshold for a given external resistor value (R<sub>LIM</sub>).

$$I_{LIM}(A) = \frac{6.8}{R_{LIM}(k\Omega)}$$

8 Detailed Description

8.3 Feature Description (continued)

Programming the Current-Limit Threshold (continued)

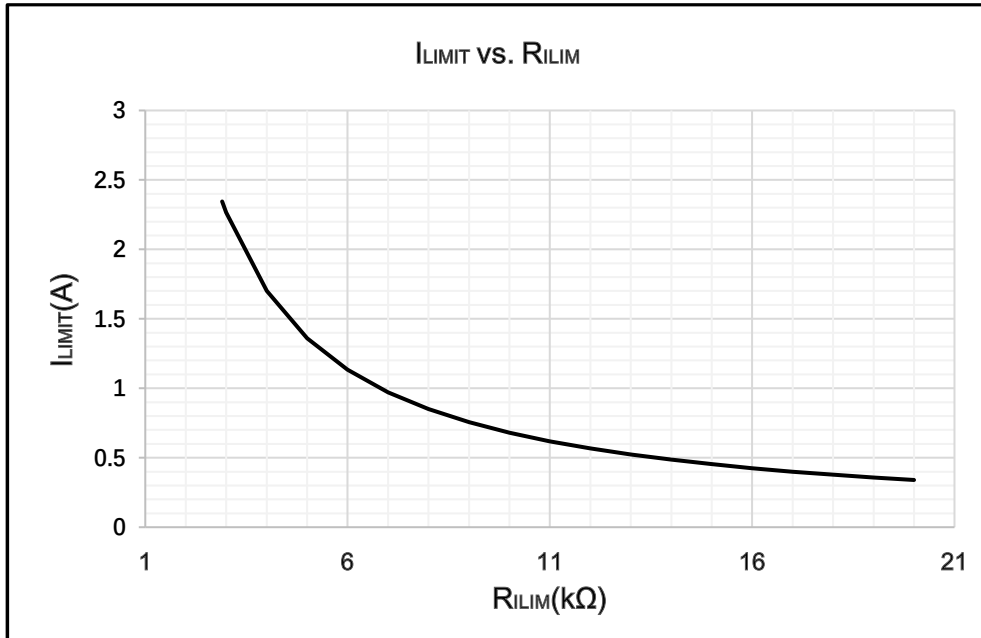

Figure 10-1. Current Limit Threshold vs R<sub>ILIM</sub>

**NOTE**

The application information in this section is not part of the data sheet component specification, and JSCJ makes no commitment or statement to guarantee its accuracy or completeness. Customers are responsible for determining the rationality of corresponding components in their circuit design and making tests and verifications to ensure the normal realization of their circuit design.

## 9 Notes and Revision History

### 9.1 Associated Product Family and Others

To view other products of the same type or IC products of other types, please click the official website of JSCJ -- [https: www.jscj-elec.com](https://www.jscj-elec.com) for more details.

### 9.2 Notes

#### Electrostatic Discharge Caution



This IC may be damaged by ESD. Relevant personnel shall comply with correct installation and use specifications to avoid ESD damage to the IC. If appropriate measures are not taken to prevent ESD damage, the hazards caused by ESD include but are not limited to degradation of integrated circuit performance or complete damage of integrated circuit. For some precision integrated circuits, a very small parameter change may cause the whole device to be inconsistent with its published specifications.

### 9.3 Revision History

March, 2025: released CJLS2101 series rev - 1.0

## 10 Orderable, Mechanical, and Packaging Information

The following pages include mechanical packaging and orderable information. This information is the most current data available for the designated devices. This data is subject to change without notice and revision of this document. For browser based versions of this data sheet, refer to the left hand navigation.

Orderable Information

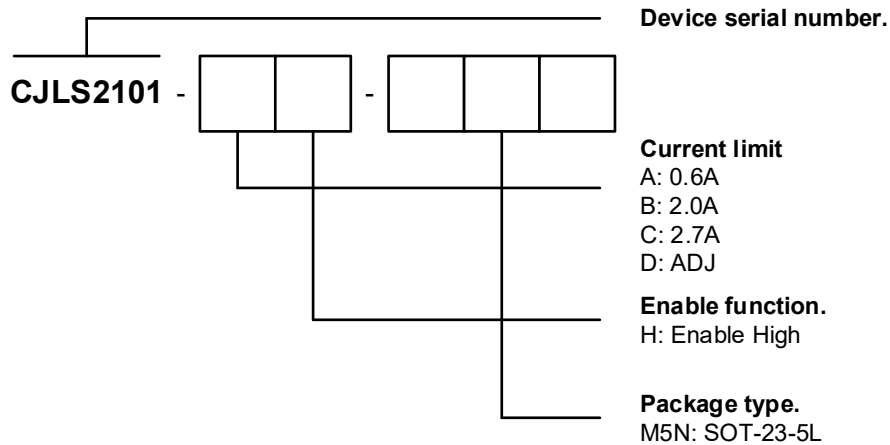

Figure a. Naming Conventions

DEVICE	PACKAGE	OPTEMP	ECOPLAN	MSL	PACKINGOPTION	SORT
<b>Pins Packaged Products</b>						
CJLS2101AH	SOT-23-5L	-40~85°C	RoHS & Green	Level3 168HR	Tape and Reel 3000Units/Reel	Customized
CJLS2101BH	SOT-23-5L	-40~85°C	RoHS & Green	Level3 168HR	Tape and Reel 3000Units/Reel	Active
CJLS2101CH	SOT-23-5L	-40~85°C	RoHS & Green	Level3 168HR	Tape and Reel 3000Units/Reel	Active
CJLS2101DH	SOT-23-5L	-40~85°C	RoHS & Green	Level3 168HR	Tape and Reel 3000Units/Reel	Active

**Note:**

**ECOPLAN:** For the RoHS and Green certification standards of this product, please refer to the official report provided by JSCJ.

**MSL:** Moisture Sensitivity Level. Determined according to JEDEC industry standard classification.

**SORT:** Specifically defined as follows:

Active: Recommended for new products;

Customized: Products manufactured to meet the specific needs of customers;

Preview: The device has been released and has not been fully mass produced. The sample may or may not be available;

NoRD: It is not recommended to use the device for new design. The device is only produced for the needs of existing customers;

Obsolete: The device has been discontinued.

## Mechanical Information

### SOT-23-5L Mechanical Information

#### SOT-23-5L Outline Dimensions

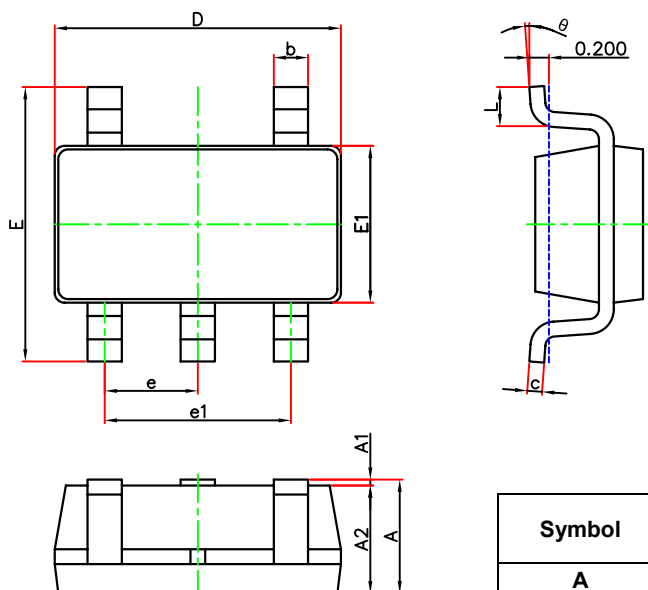

Symbol	Dimensions In Millimeters		Dimensions In Inches	
	Min.	Max.	Min.	Max.
A	1.050	1.250	0.041	0.049
A1	0.000	0.100	0.000	0.004
A2	1.050	1.150	0.041	0.045
b	0.300	0.500	0.012	0.020
c	0.100	0.200	0.004	0.008
D	2.820	3.020	0.111	0.119
E	2.650	2.950	0.104	0.116
E1	1.500	1.700	0.059	0.067
e	0.950(BSC)		0.037(BSC)	
e1	1.800	2.000	0.071	0.079
L	0.300	0.600	0.012	0.024
$\theta$	0°	8°	0°	8°

#### SOT-23-5L Suggested Pad Layout

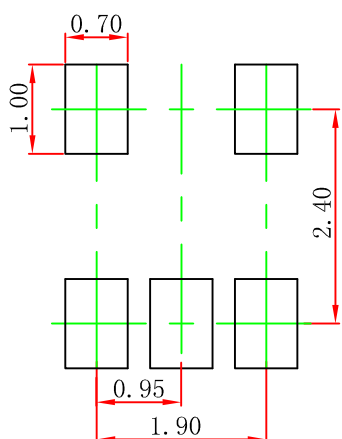

#### Note:

1. Controlling dimension: in millimeters.
2. General tolerance:  $\pm 0.05$ mm.
3. The pad layout is for reference purpose only.

## Packaging Information

### SOT-23-5L Tape and Reel Information

### SOT-23-5L Tape and Reel Information

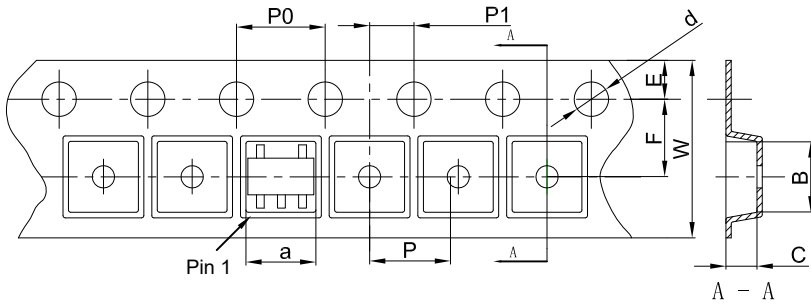

#### Packaging Description:

SOT-23-5L parts are shipped in tape. The carrier tape is made from a dissipative (carbon filled) polycarbonate resin. The cover tape is a multilayer film (Heat Activated Adhesive in nature) primarily composed of polyester film, adhesive layer, sealant, and anti-static sprayed agent. These reeled parts in standard option are shipped with 3,000 units per 7" or 18.0cm diameter reel. The reels are clear in color and is made of polystyrene plastic (anti-static coated).

Dimensions are in millimeter										
Pkg type	a	B	C	d	E	F	P0	P	P1	W
SOT-23-5L	3.17	3.23	1.37	Ø1.55	1.75	3.50	4.00	4.00	2.00	8.00

### SOT-23-5L Tape Leader and Trailer

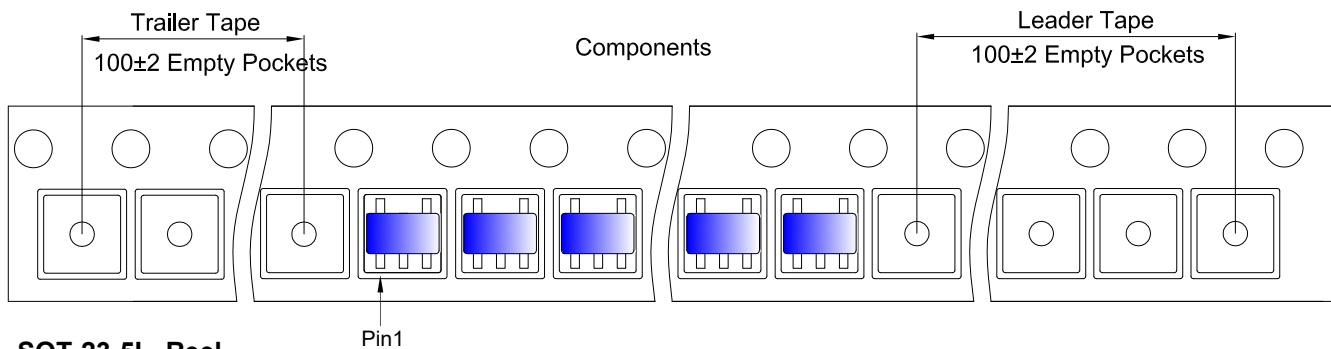

### SOT-23-5L Reel

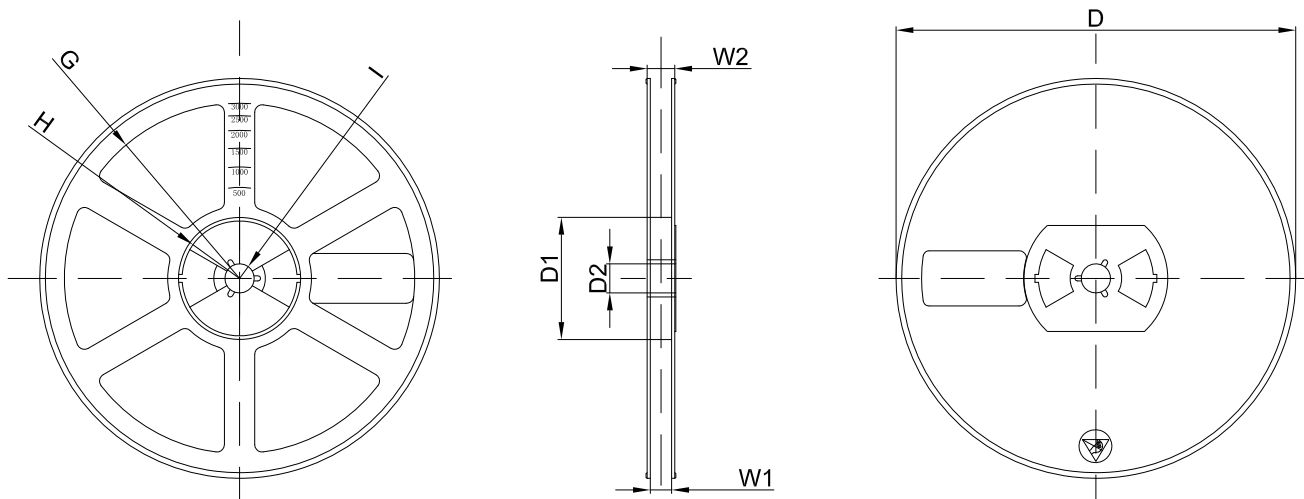

Dimensions are in millimeter								
Reel Option	D	D1	D2	G	H	I	W1	W2
7" Dia	Ø180.00	60.00	13.00	R78.00	R25.60	R6.50	9.50	13.10

REEL	Reel Size	Box	Box Size(mm)	Carton	Carton Size(mm)	G.W.(kg)
3000 pcs	7 inch	30,000 pcs	203×203×195	120,000 pcs	438×438×220	