

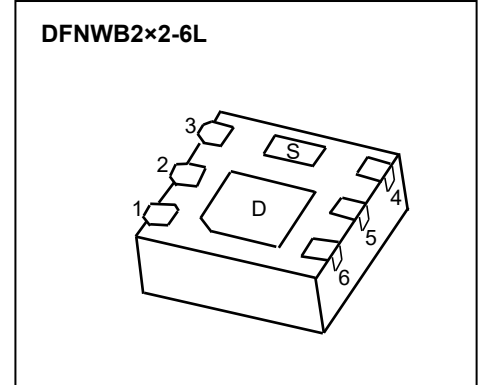

**DFNWB2×2-6L Plastic-Encapsulate MOSFETS**

**CJMN3010L** N-Channel MOSFET

$V_{(BR)DSS}$	$R_{DS(on)TYP}$	$I_D$
30V	8.3mΩ@ 4.5V	10A
	8.4mΩ@ 3.7V	
	10mΩ@ 2.5V	
	13mΩ@ 1.8V	



**FEATURES**

- TrenchFET Power MOSFET
- Small package DFNWB2×2-6L
- ESD Protected

**APPLICATION**

- Load Switch for Portable Applications

**MARKING:**

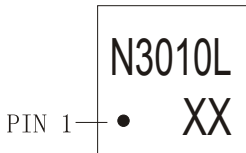

N3010L = Part No.  
 Solid dot = Pin1 indicator.  
 XX = Code.

**Equivalent Circuit**

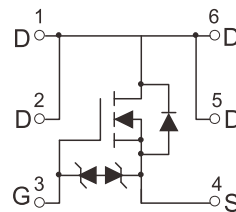

**ABSOLUTE MAXIMUM RATINGS (T<sub>A</sub>=25°C unless otherwise noted)**

Parameter	Symbol	Value	Unit
Drain-Source Voltage (V <sub>DS</sub> )	$V_{DS}$	30	V
Drain-Source Voltage (V <sub>DS</sub> )	$V_{DS}$	† 10	V
Continuous Drain Current (I <sub>D</sub> )	$I_D$	10	A
Transient Drain Current (I <sub>DM</sub> )	$I_{DM}$	40	A
Gate-Source Voltage (V <sub>GS</sub> )	$V_{GS}$	45	V
Drain-Source On-Resistance (R <sub>DS(on)</sub> )	$R_{DS(on)}$	1.0	mΩ
V <sub>GS</sub> (Pulse) (V <sub>GS</sub> )	$V_{GS}$	4.0	V
V <sub>GS</sub> (DC) (V <sub>GS</sub> )	$V_{GS}$	125	
Operating Junction and Storage Temperature Range	T <sub>J</sub> , T <sub>stg</sub>	-55~+150	°C

# MOSFET ELECTRICAL CHARACTERISTICS

$T_A=25^{\circ}\text{C}$  unless otherwise specified

Parameter	Symbol	Test Condition	Min	Typ	Max	Unit	
<b>Off characteristics</b>							
Drain-source breakdown voltage	$V_{(BR)DSS}$	$V_{GS} = 0V, I_D = 250\mu A$	30			V	
Zero gate voltage drain current	$I_{DSS}$	$V_{DS} = 24V, V_{GS} = 0V$	$T_J = 25^{\circ}\text{C}$		1.0	$\mu A$	
			$T_J = 125^{\circ}\text{C}$		100		
Gate-body leakage current	$I_{GSS}$	$V_{DS} = 0V, V_{GS} = \pm 10V$			$\pm 9$	$\mu A$	
<b>On characteristics <sup>④</sup></b>							
Gate-threshold voltage	$V_{GS(th)}$	$V_{DS} = V_{GS}, I_D = 250\mu A$	0.45	0.8	1.0	V	
Static drain-source on-state resistance	$R_{DS(on)}$	$V_{GS} = 4.5V, I_D = 8A$		8.3	14	m $\Omega$	
			$V_{GS} = 3.7V, I_D = 8A$		8.4		15
			$V_{GS} = 2.5V, I_D = 7.2A$		10		19
			$V_{GS} = 1.8V, I_D = 3.7A$		13		23
<b>Dynamic characteristics <sup>⑤</sup></b>							
Input capacitance	$C_{iss}$	$V_{DS} = 15V, V_{GS} = 0V, f = 1MHz$		1773		pF	
Output capacitance	$C_{oss}$			125			
Reverse transfer capacitance	$C_{rss}$			107			
Gate resistance	$R_g$	$f = 1MHz$		3		$\Omega$	
<b>Switching characteristics <sup>⑤</sup></b>							
Total gate charge	$Q_g$	$V_{GS} = 6V, V_{DS} = 15V, I_D = 10A$		40		nC	
Gate-source charge	$Q_{gs}$			3			
Gate-drain charge	$Q_{gd}$			6			
Turn-on delay time	$t_{d(on)}$	$V_{DS} = 20V, I_D = 10A, V_{GS} = 10V, R_g = 3\Omega$		7		ns	
Turn-on rise time	$t_r$			45			
Turn-off delay time	$t_{d(off)}$			48			
Turn-off fall time	$t_f$			74			
<b>Drain-Source Diode Characteristics</b>							
Drain-source diode forward voltage	$V_{SD}$ <sup>④</sup>	$V_{GS} = 0V, I_S = 2A$			1.2	V	
Continuous drain-source diode forward current	$I_S$				10	A	
Pulsed drain-source diode forward current	$I_{SM}$ <sup>②</sup>				40	A	

Notes:

- $T_C = 25^{\circ}\text{C}, t \leq 10s, T_J (\text{MAX}) = 150^{\circ}\text{C}$ .
- $P_{WV} \leq 10\mu s, \text{Duty cycle} \leq 1\%$ .
- EAS condition:  $V_{DD} = 20V, V_{GS} = 6V, L = 0.5mH, R_g = 25\Omega$  Starting  $T_J = 25^{\circ}\text{C}$ .
- Pulse Test : Pulse Width  $\leq 300\mu s, \text{duty cycle} \leq 2\%$ .
- Guaranteed by design, not subject to production.
- Device mounted on FR-4 board (25.4mm $\times$ 24.4mm $\times$ 1.55mm) in a still air environment with  $T_A = 25^{\circ}\text{C}$ .

# Typical Characteristics

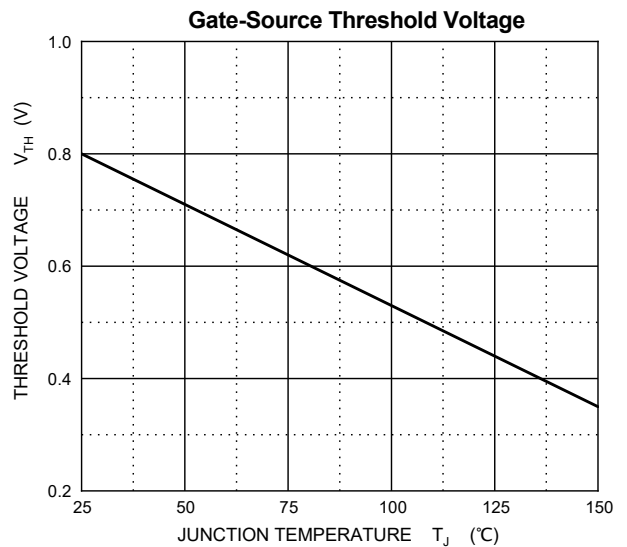
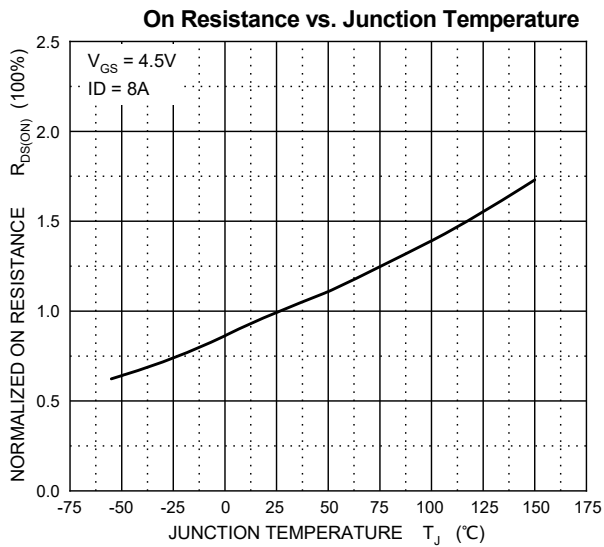
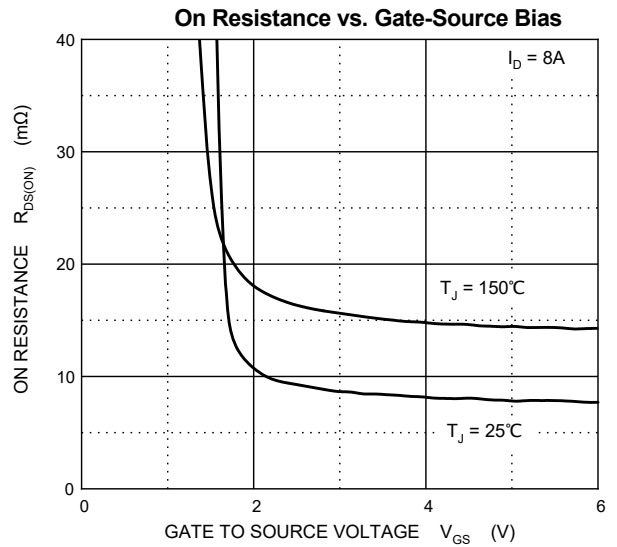
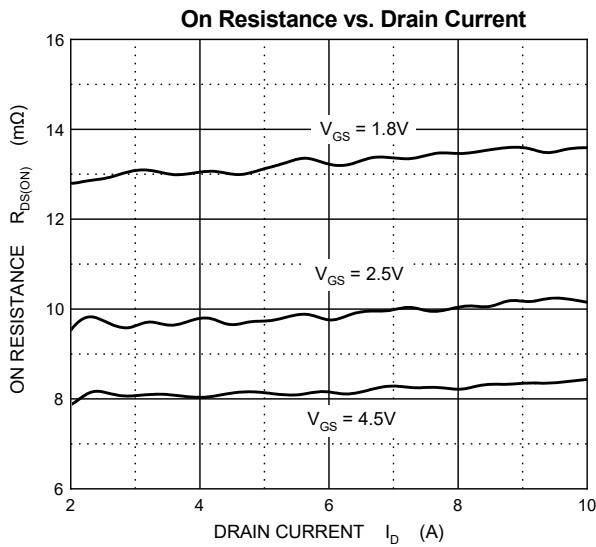
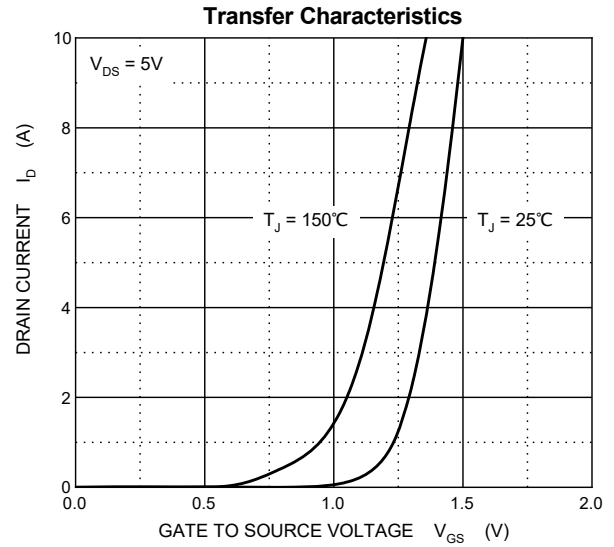
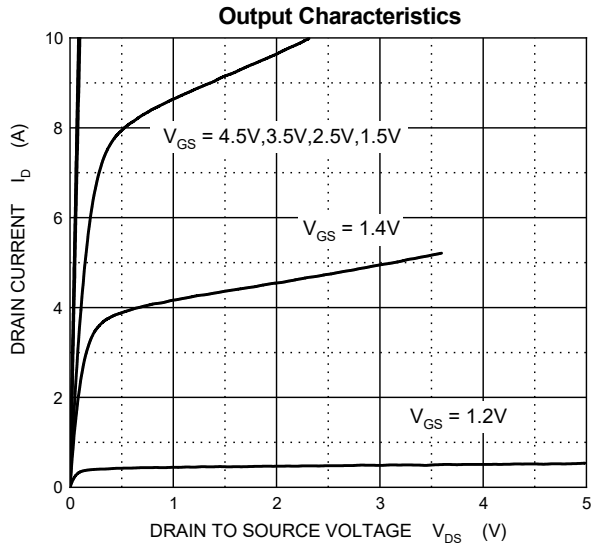

# Typical Characteristics

Typical Capacitances

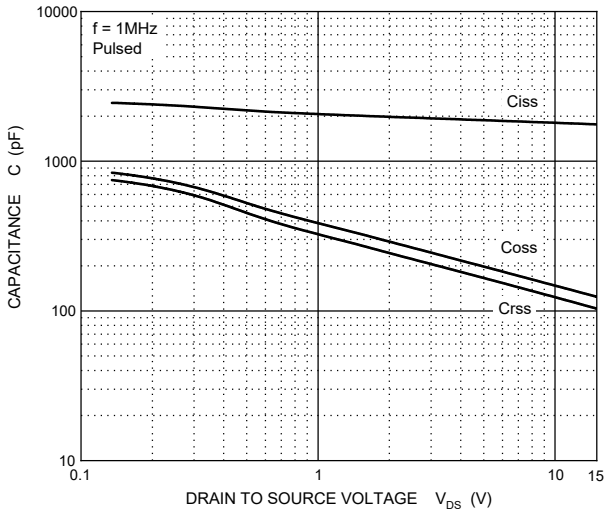

Gate Charge

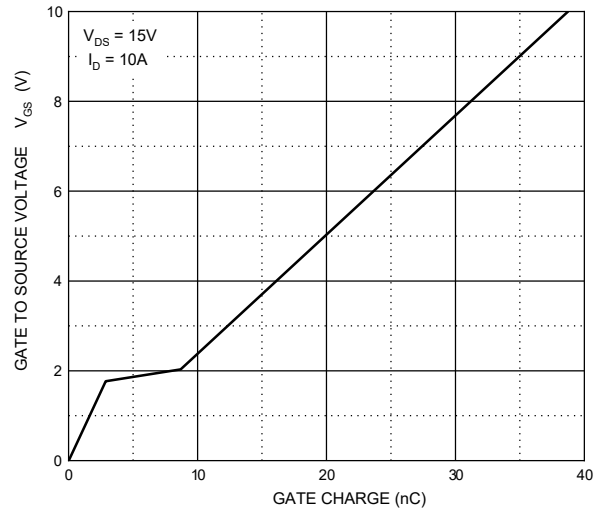

Source-Drain Diode Forward Characteristics

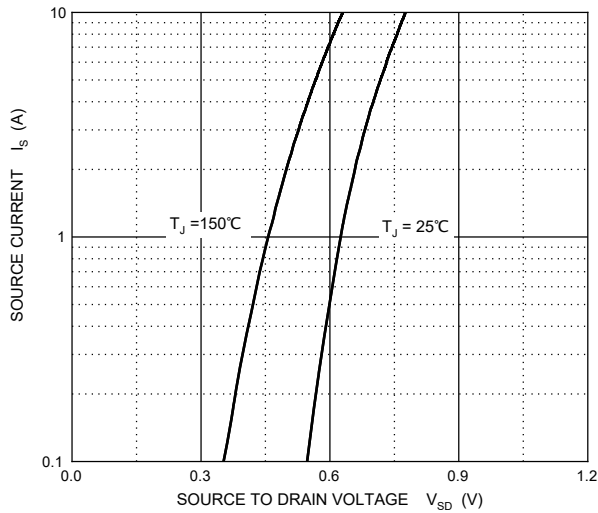

Maximum Safe Operating Area

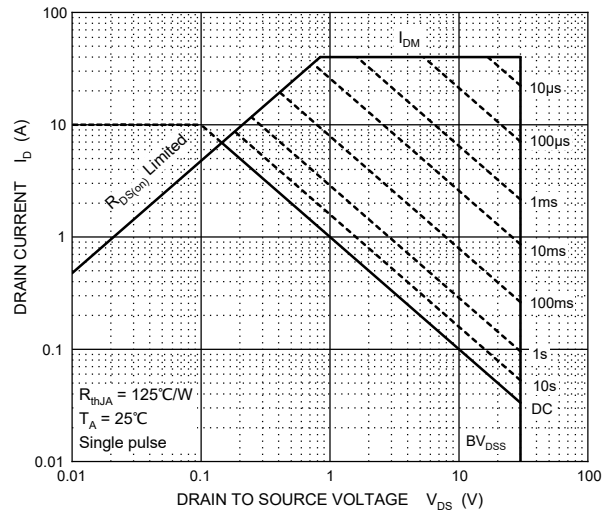

Transient Thermal Impedance, Junction-Ambient

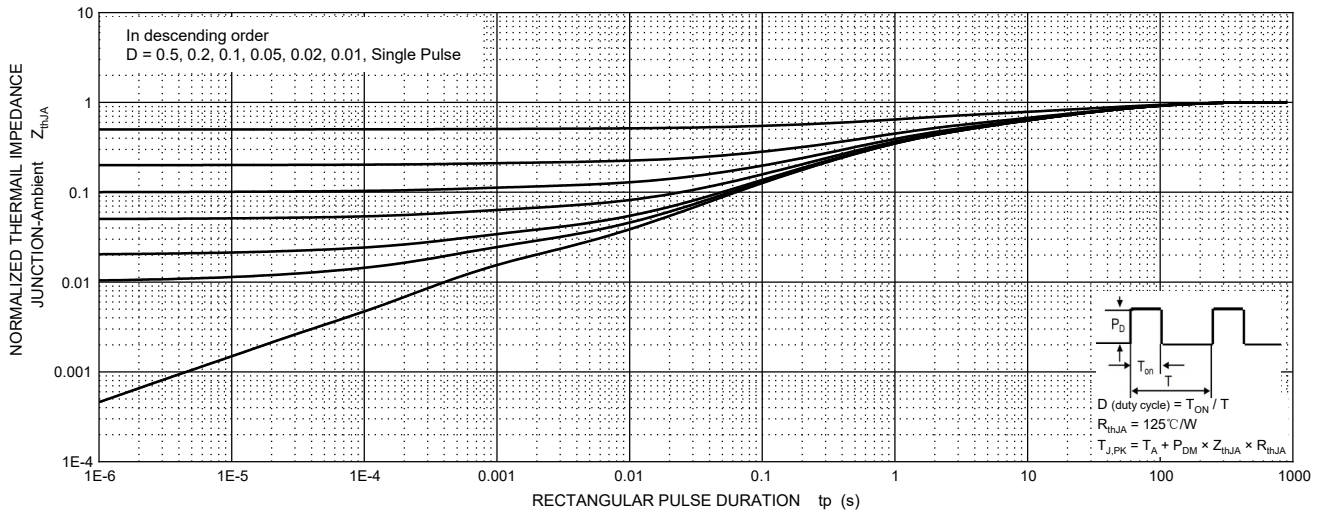

## DFNWB2X2-6L-J Package Outline Dimensions

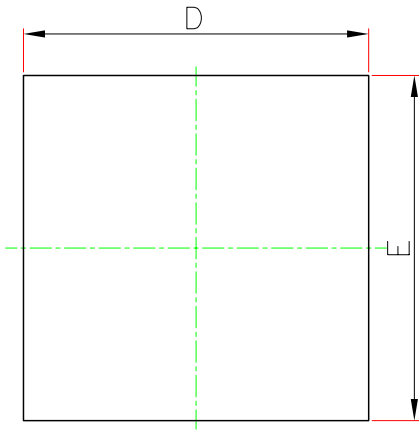

TOP VIEW  
[顶视图]

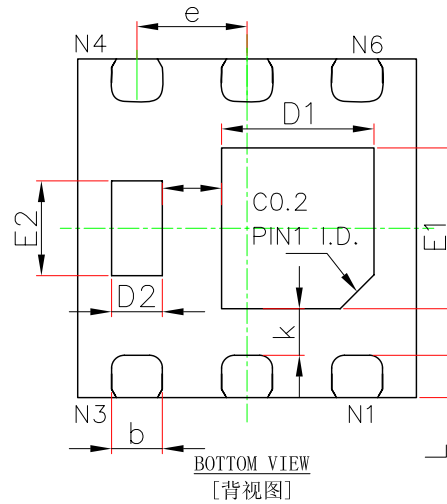

BOTTOM VIEW  
[背视图]

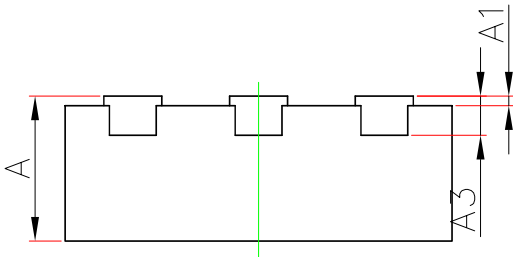

SIDE VIEW  
[侧视图]

Symbols	Dimensions in Millimeters		Dimensions in Inches	
	Min.	Max.	Min.	Max.
A	0.700	0.800	0.028	0.031
A1	0.000	0.050	0.000	0.002
A3	0.203REF.		0.008REF.	
D	1.900	2.100	0.075	0.083
E	1.900	2.100	0.075	0.083
D1	0.800	1.000	0.031	0.039
E1	0.850	1.050	0.033	0.041
D2	0.200	0.400	0.008	0.016
E2	0.460	0.660	0.018	0.026
b	0.250	0.350	0.010	0.014
e	0.650BSC.		0.026BSC.	
k	0.275REF.		0.011REF.	
k1	0.350REF.		0.014REF.	
L	0.174	0.326	0.007	0.013

## DFNWB2X2-6L-J Suggested Pad Layout

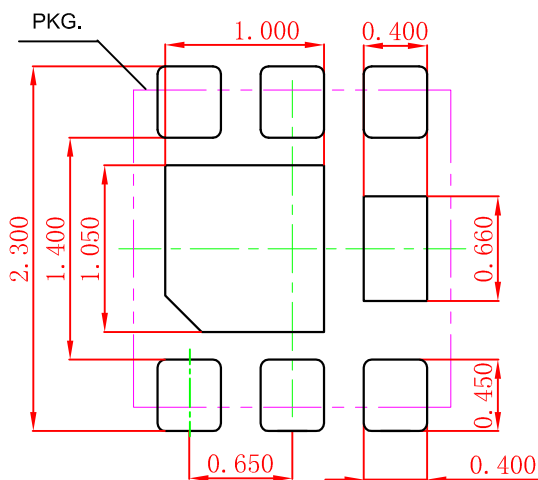

Note:

1. Controlling dimension: in millimeters.
2. General tolerance:  $\pm 0.050\text{mm}$ .
3. The pad layout is for reference purposes only.

### NOTICE

JSCJ reserves the right to make modifications, enhancements, improvements, corrections or other changes without further notice to any product herein. JSCJ does not assume any liability arising out of the application or use of any product described herein.

# DFNWB2X2-6L Tape and Reel

## DFNWB2×2-6L Embossed Carrier Tape

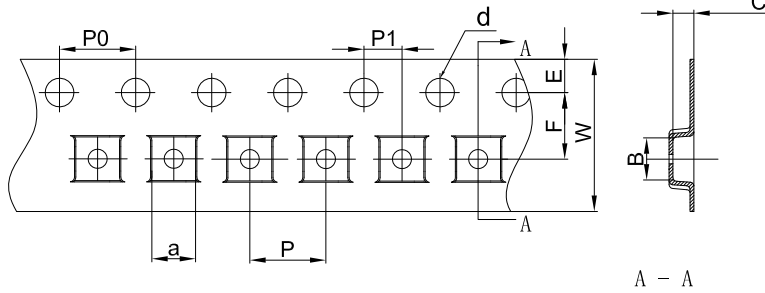

### Packaging Description:

DFNWB2×2-6L parts are shipped in tape. The carrier tape is made from a dissipative (carbon filled) polycarbonate resin. The cover tape is a multilayer film (Heat Activated Adhesive in nature) primarily composed of polyester film, adhesive layer, sealant, and anti-static sprayed agent. These reeled parts in standard option are shipped with 3,000 units per 7" or 18.0cm diameter reel. The reels are clear in color and is made of polystyrene plastic (anti-static coated).

Dimensions are in millimeter

Pkg type	a	B	C	d	E	F	P0	P	P1	W
DFNWB2×2-6L	2.30	2.30	1.10	Ø1.50	1.75	3.50	4.00	4.00	2.00	8.00

## DFNWB2×2-6L Tape Leader and Trailer

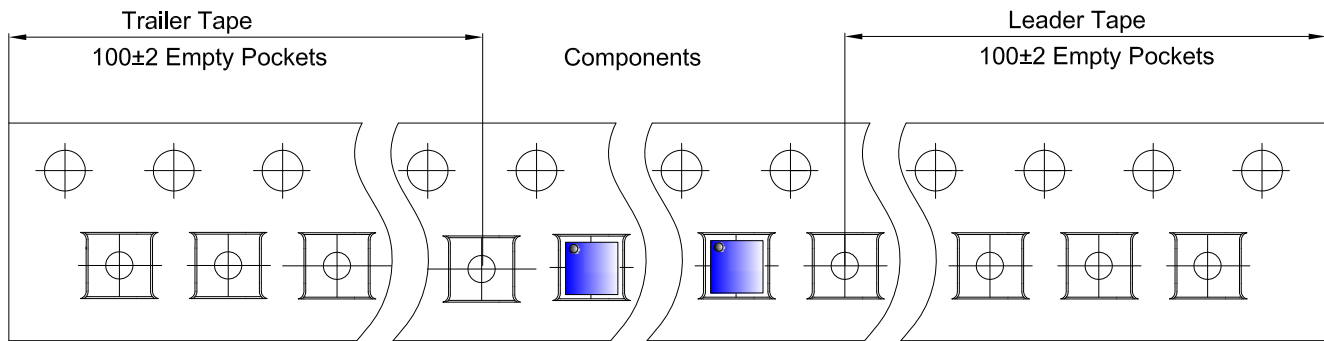

## DFNWB2×2-6L Reel

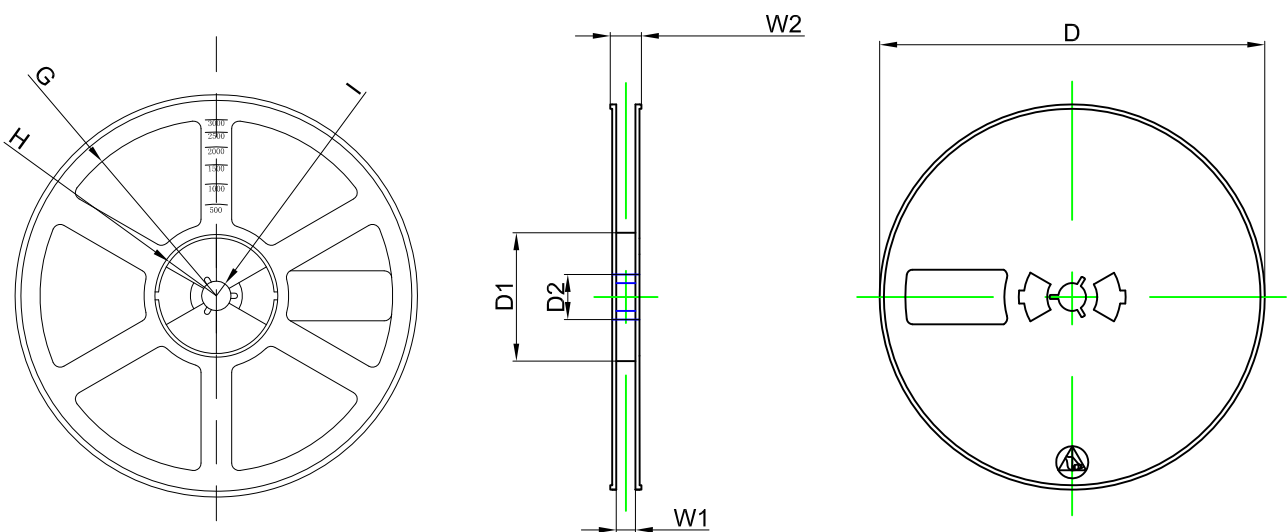

Dimensions are in millimeter

Reel Option	D	D1	D2	G	H	I	W1	W2
7" Dia	Ø180.00	60.00	13.00	R78.00	R25.60	R6.50	9.50	13.10

REEL	Reel Size	Box	Box Size(mm)	Carton	Carton Size(mm)	G.W.(kg)
3000 pcs	7 inch	30,000 pcs	203×203×195	120,000 pcs	438×438×220	