



## CJOA156x Series CMOS Amplifier

### 1 Introduction

The CJOA156x family of single, dual, and quad channel operational amplifiers represents a new generation of general-purpose, low-power op-amps. Featuring rail-to-rail input and output (RRIO) swings, low quiescent current (typical 700 $\mu$ A) combined with a wide bandwidth (7MHz) makes this family very attractive for a variety of battery-powered applications that require a good balance between cost and performance, such as motor phase current sensing, photodiode amplification, barcode scanners and white goods. The low input bias current supports these amplifiers to be used in applications with mega-ohm source impedances. The robust design of the CJOA156x amplifiers provides ease-of-use to the circuit designer: unity-gain stability with capacitive loads of up to 500 pF, integrated RF/EMI rejection filter, no phase reversal in overdrive conditions, and high electro-static discharge (ESD) protection (3kV HBM). The CJOA156x amplifiers are optimized for operation at voltages as low as +2.3V ( $\pm$ 1.15V) and up to +5.5V ( $\pm$ 2.75V) over the extended temperature range of -40°C to +125°C.

The single version CJOA1561 device is available in SOT23-5L package. The dual CJOA1562 device is offered in SOP8, MSOP8 and DFNWB2 $\times$ 2-8L package. The quad CJOA1564 device is offered in SOP14 and TSSOP14 package.

### 2 Features

- Wide Unity-Gain Bandwidth: 7MHz
- High Slew Rate: 10V/ $\mu$ s
- Fast Settling: 0.3 $\mu$ s to 0.1%
- Low Input Offset Voltage:  $\pm$ 0.7mV
- Single 2.3V to 5.5V Power Supply Range
- Rail-to-Rail Input and Output
- Low Supply Current: 700 $\mu$ A at 5V Supply Per Amplifier
- Internal RF/EMI Filter
- Extended Temperature Range -40°C to +125°C

### 3 Applications

- Motor Phase Current Sense
- Photodiode Amplification
- Active Filters
- Driving A/D Converters
- Portable Equipment
- Battery-Powered Instrumentation

### 4 Available Packages

PART NUMBER	PACKAGE
CJOA1561-M5N	SOT-23-5L
CJOA1562-PAN	SOP8
CJOA1562-PDN	MSOP8
CJOA1562-DCN	DFNWB2 $\times$ 2-8L
CJOA1564-PHN	SOP14
CJOA1564-PIN	TSSOP14

**5 Orderable Information**

MODEL	DEVICE	PACKAGE	OP TEMP	ECO PLAN	MSL	PACKING OPTION	SORT
CJOA1561	CJOA1561-M5N	SOT-23-5L	-40 ~ 125°C	RoHS & Green	Level 3 168 HR	Tape and Reel 3000 Units / Reel	Active
CJOA1562	CJOA1562-PAN	SOP8	-40 ~ 125°C	RoHS & Green	Level 3 168 HR	Tape and Reel 4000 Units / Reel	Active
	CJOA1562-PDN	MSOP8	-40 ~ 125°C	RoHS & Green	Level 3 168 HR	Tape and Reel 4000 Units / Reel	Active
	CJOA1562-DCN	DFNWB2x2-8L	-40 ~ 125°C	RoHS & Green	Level 3 168 HR	Tape and Reel 3000 Units / Reel	Active
CJOA1564	CJOA1564-PHN	SOP14	-40 ~ 125°C	RoHS & Green	Level 3 168 HR	Tape and Reel 2500 Units / Reel	Active
	CJOA1564-PIN	TSSOP14	-40 ~ 125°C	RoHS & Green	Level 3 168 HR	Tape and Reel 3000 Units / Reel	Active
Others	-	-	-	-	-	-	Customized

**Note:**

**ECO PLAN:** For the RoHS and Green certification standards of this product, please refer to the official report provided by JSCJ.

**MSL:** Moisture Sensitivity Level. Determined according to JEDEC industry standard classification.

**SORT:** Specifically defined as follows:

Active: Recommended for new products;

Customized: Products manufactured to meet the specific needs of customers;

Preview: The device has been released and has not been fully mass produced. The sample may or may not be available;

NoRD: It is not recommended to use the device for new design. The device is only produced for the needs of existing customers; Obsolete: The device has been discontinued.

## 6 Pin Configuration and Marking Information

### 6.1 Pin Configuration and Function

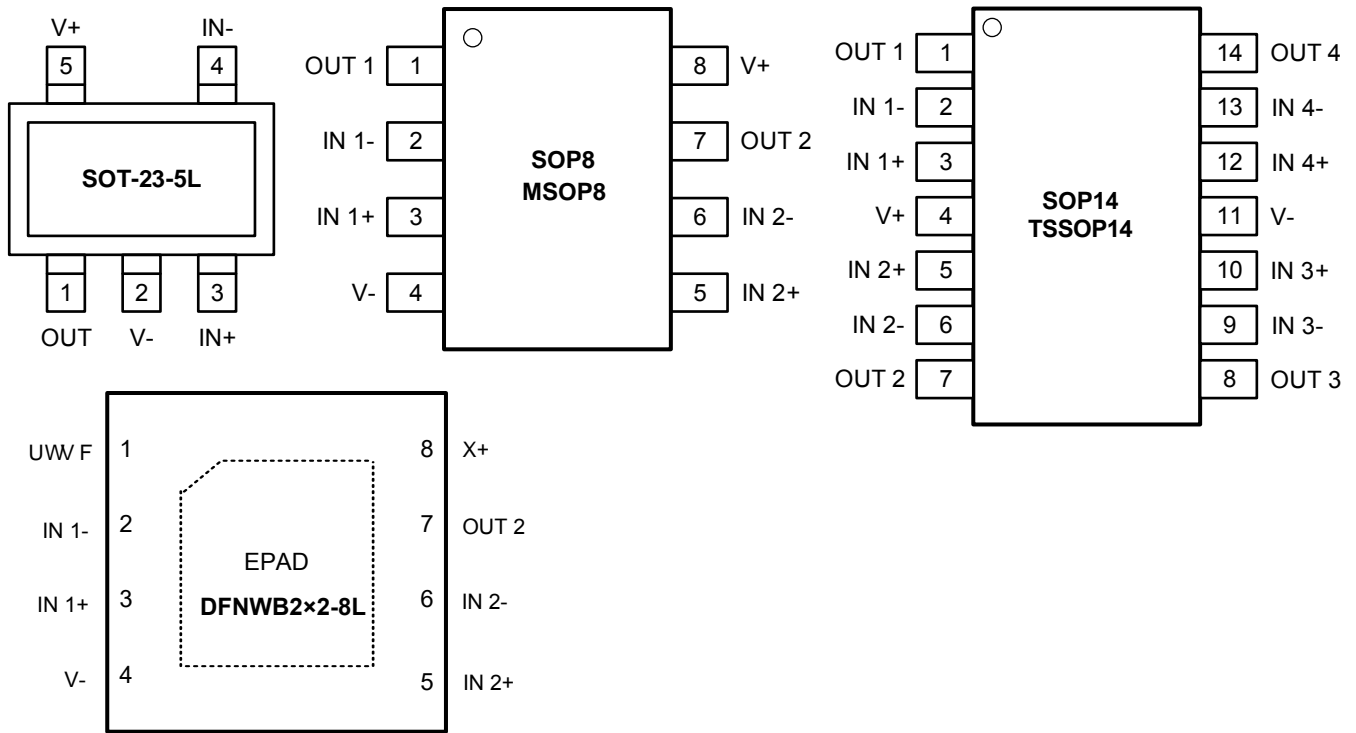
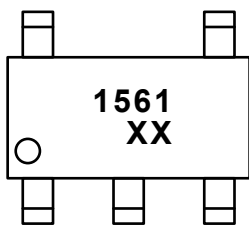

Figure 6-1. CJOA156x Pin Map

PIN NAME	CJOA1561	CJOA1562	CJOA1564	I / O	DESCRIPTION
	SOT-23-5L	SOP8/MSOP8 DFNWB2x2-8L	SOP14 TSSOP14		
OUT1	1	1	1	O	Output of the operational amplifier 1.
IN1-	4	2	2	I	Negative input of the operational amplifier 1.
IN1+	3	3	3	I	Positive input of the operational amplifier 1.
V+	5	8	4	-	Positive (highest) supply.
IN2+	-	5	5	I	Positive input of the operational amplifier 2.
IN2-	-	6	6	I	Negative input of the operational amplifier 2.
OUT2	-	7	7	O	Output of the operational amplifier 2.
OUT3	-	-	8	O	Output of the operational amplifier 3.
IN3-	-	-	9	I	Negative input of the operational amplifier 3.
IN3+	-	-	10	I	Positive input of the operational amplifier 3.
V-	2	4	11	-	Negative (lowest) supply or ground for single supply.
IN4+	-	-	12	I	Positive input of the operational amplifier 4.
IN4-	-	-	13	I	Negative input of the operational amplifier 4.
OUT4	-	-	14	O	Output of the operational amplifier 4.
-	-	EPAD (DFNWB2x2-8L)	-	-	Exposed pad. Connected to GND or left floating.

6 Pin Configuration and Marking Information

6.2 Marking Information



SOT-23-5L

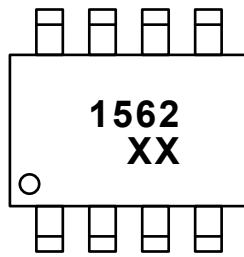

SOP8/MSOP8

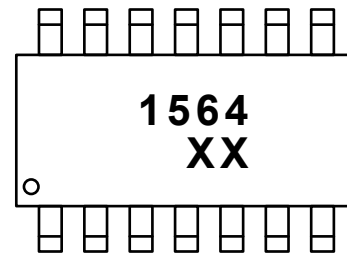

SOP14

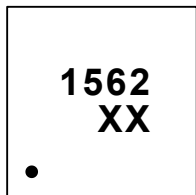

DFNWB2x2-8L

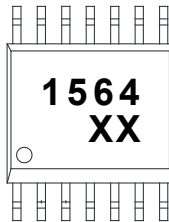

TSSOP14

"156x": Device number.

"XX": Code, indicates weekly record information.

## 7 Specifications

### 7.1 Absolute Maximum Ratings

(over operating ambient temperature range, unless otherwise specified)<sup>(1)</sup>

CHARACTERISTIC		SYMBOL	VALUE	UNIT
Supply voltage[(V <sub>+</sub> )-(V <sub>-</sub> )]		V <sub>S</sub>	10	V
Signal input pins	Voltage <sup>(2)</sup>		(V <sub>-</sub> )-0.5V ~ (V <sub>+</sub> )+0.5V	V
	Current <sup>(2)</sup>		±10	mA
Output short-circuit		T <sub>sc</sub>	Continuous <sup>(3)</sup>	mA
Maximum junction temperature		T <sub>J MAX</sub>	150	°C
Storage temperature		T <sub>stg</sub>	-65 ~ 150	°C
Soldering temperature & time		T <sub>solder</sub>	260°C, 10s	-

(1) Stresses beyond those listed under *Absolute Maximum Ratings* may cause permanent damage to the device. These are stress ratings only, which do not imply functional operation of the device at these or any other conditions beyond those indicated under *Recommended Operating Conditions*. Exposure to absolute-maximum rated conditions for extended periods may affect device reliability.

(2) Input pins are diode-clamped to the power-supply rails. Current limit input signals that can swing more than 0.5V beyond the supply rails to 10mA or less.

(3) Short circuits from outputs to V<sub>S</sub> can cause excessive heating and eventual destruction. A heat sink may be required to keep the junction temperature below the absolute maximum. This depends on the power supply voltage and how many amplifiers are shorted. Thermal resistance varies with the amount of PC board metal connected to the package. The specified values are for short traces connected to the leads.

### 7.2 Recommend Operating Conditions

(over operating ambient temperature range, unless otherwise specified)

PARAMETER		SYMBOL	MIN.	NOM.	MAX.	UNIT
Power supply range	T <sub>A</sub> = -40 ~ 125°C	V <sub>S</sub>	2.3	-	5.5	V
Operating ambient temperature		T <sub>A</sub>	-40	-	125	°C

## 7 Specifications

### 7.3 ESD Ratings

ESD RATINGS		VALUE	UNIT
Electrostatic discharge	Human-body model (HBM), per ANSI/ESDA/JEDEC JS-001 <sup>(4)</sup>	3000	V
	Charged-device model (CDM), per JEDEC specification JESD22-C101 <sup>(5)</sup>	150	

(4) JEDEC document JEP155 states that 500V HBM allows safe manufacturing with a standard ESD control process.

(5) JEDEC document JEP157 states that 250V CDM allows safe manufacturing with a standard ESD control process.

### 7.4 Thermal Information

THERMAL METRIC <sup>(6)</sup>	SYMBOL	CJOA156x Series		UNIT
		SOT-23-5L	SOP8	
Junction-to-ambient thermal resistance	$R_{\theta JA}$			°C/W
		192.3	125.0	
		<b>MSOP8</b>	<b>SOP14</b>	
		201.6	115.7	
		<b>DFNWB2×2-8L</b>	<b>TSSOP14</b>	
		94.7	119.0	
Reference maximum power dissipation for continuous operation	$P_{D Ref}$			W
		<b>MSOP8</b>	<b>SOP14</b>	
		0.62	1.08	
		<b>DFNWB2×2-8L</b>	<b>TSSOP14</b>	
		1.32	1.05	

(6)  $T_A = 25^\circ\text{C}$ , measured on evaluation board with 1oz. copper traces of minimum pad size, all device outputs were active.

## 7 Specifications

### 7.5 Electrical Characteristics

$V_S = 5.0V$ ,  $T_A = +25^\circ C$ ,  $V_{CM} = V_S/2$ ,  $V_O = V_S/2$ ,  $R_L = 10k\Omega$  connected to  $V_S/2$ , unless otherwise noted.

CHARACTERISTIC	SYMBOL	TEST CONDITIONS	MIN.	TYP.	MAX.	UNIT
<b>OFFSET VOLTAGE</b>						
Input offset voltage	$V_{OS}$	-	-	$\pm 0.7$	$\pm 2.5$	mV
Offset voltage drift	$V_{OS\ TC}$	$T_A = -40$ to $+125^\circ C$	-	$\pm 1$	-	$\mu V/^\circ C$
Power supply rejection ratio	PSRR	$V_S = 2.0$ to $5.5V$ , $V_{CM} < (V+) - 2V$	90	106	-	dB
		$T_A = -40$ to $+125^\circ C$	85	-	-	
<b>INPUT VOLTAGE</b>						
Common-mode voltage range	$V_{CM}$	-	$(V-) - 0.1$	-	$(V+) + 0.1$	V
Common-mode rejection ratio	CMRR	$V_S = 5.5V$ , $V_{CM} = -0.1$ to $5.6V$	72	85	-	dB
		$V_S = 5.5V$ , $V_{CM} = 0$ to $3.4V$ , $T_A = -40$ to $+125^\circ C$	85	-	-	
		$V_S = 2.3V$ , $V_{CM} = -0.1$ to $2.4V$	70	82	-	
		$V_S = 2.3V$ , $V_{CM} = 0$ to $0.7V$ , $T_A = -40$ to $+125^\circ C$	76	-	-	
<b>INPUT BIAS CURRENT</b>						
Input bias current	$I_B$	-	-	1	-	pA
		$T_A = 85^\circ C$	-	150	-	
		$T_A = 125^\circ C$	-	900	-	
Input offset current	$I_{OS}$	-	-	1	-	pA
<b>NOISE</b>						
Input voltage noise density	$e_n$	$f = 10kHz$	-	35	-	$nV/\sqrt{Hz}$
<b>OUTPUT</b>						
High output voltage swing	$V_{OH}$	$R_L = 10k\Omega$	$(V+) - 8$	$(V+) - 5$	-	mV
		$R_L = 600\Omega$	$(V+) - 180$	$(V+) - 140$	-	
Low output voltage swing	$V_{OL}$	$R_L = 10k\Omega$	-	$(V-) + 5$	$(V-) + 7$	mV
		$R_L = 600\Omega$	-	$(V-) + 80$	$(V-) + 90$	
Short-circuit current	$I_{SOURCE}$	$R_L = 10\Omega$	-	50	-	mA
	$I_{SINK}$		-	75	-	
<b>POWER SUPPLY</b>						
Quiescent current (per comparator)	$I_Q$	$V_S = 2.5V$	-	600	700	$\mu A$
		$V_S = 5.0V$	-	700	850	

## 7 Specifications

### 7.5 Electrical Characteristics (conitnued)

$V_S = 5.0V$ ,  $T_A = +25^\circ C$ ,  $V_{CM} = V_S/2$ ,  $V_O = V_S/2$ ,  $R_L = 10k\Omega$  connected to  $V_S/2$ , unless otherwise noted.

CHARACTERISTIC	SYMBOL	TEST CONDITION	MIN.	TYP.	MAX.	UNIT
<b>OPEN-LOOP GAIN</b>						
Open-loop voltage gain	$A_{VOL}$	$R_L = 50k\Omega$ , $V_O = 0.05$ to $3.5V$	93	102	-	dB
		$R_L = 50k\Omega$ , $V_O = 0.05$ to $3.5V$ $T_A = -40$ to $+125^\circ C$	84	-	-	
		$R_L = 2k\Omega$ , $V_O = 0.15$ to $3.5V$	91	100	-	
		$R_L = 2k\Omega$ , $V_O = 0.15$ to $3.5V$ $T_A = -40$ to $+125^\circ C$	81	-	-	
<b>FREQUENCY RESPONSE</b>						
Gain bandwidth product	GBW	-	-	7	-	MHz
Slew rate	SR	$G = +1$ , $C_L = 100pF$ , $V_O = 1.5$ to $3.5 V$	-	10	-	V/ $\mu s$
Overload recovery time	$T_{OR}$	$V_{IN} \times Gain > V_S$	-	0.3	-	$\mu s$

## 7 Specifications

### 7.6 Typical Characteristics

$V_S = 5.0V$ ,  $T_A = +25^\circ C$ ,  $V_{CM} = V_S/2$ ,  $R_L = 10k\Omega$  connected to  $V_S/2$ , unless otherwise noted.

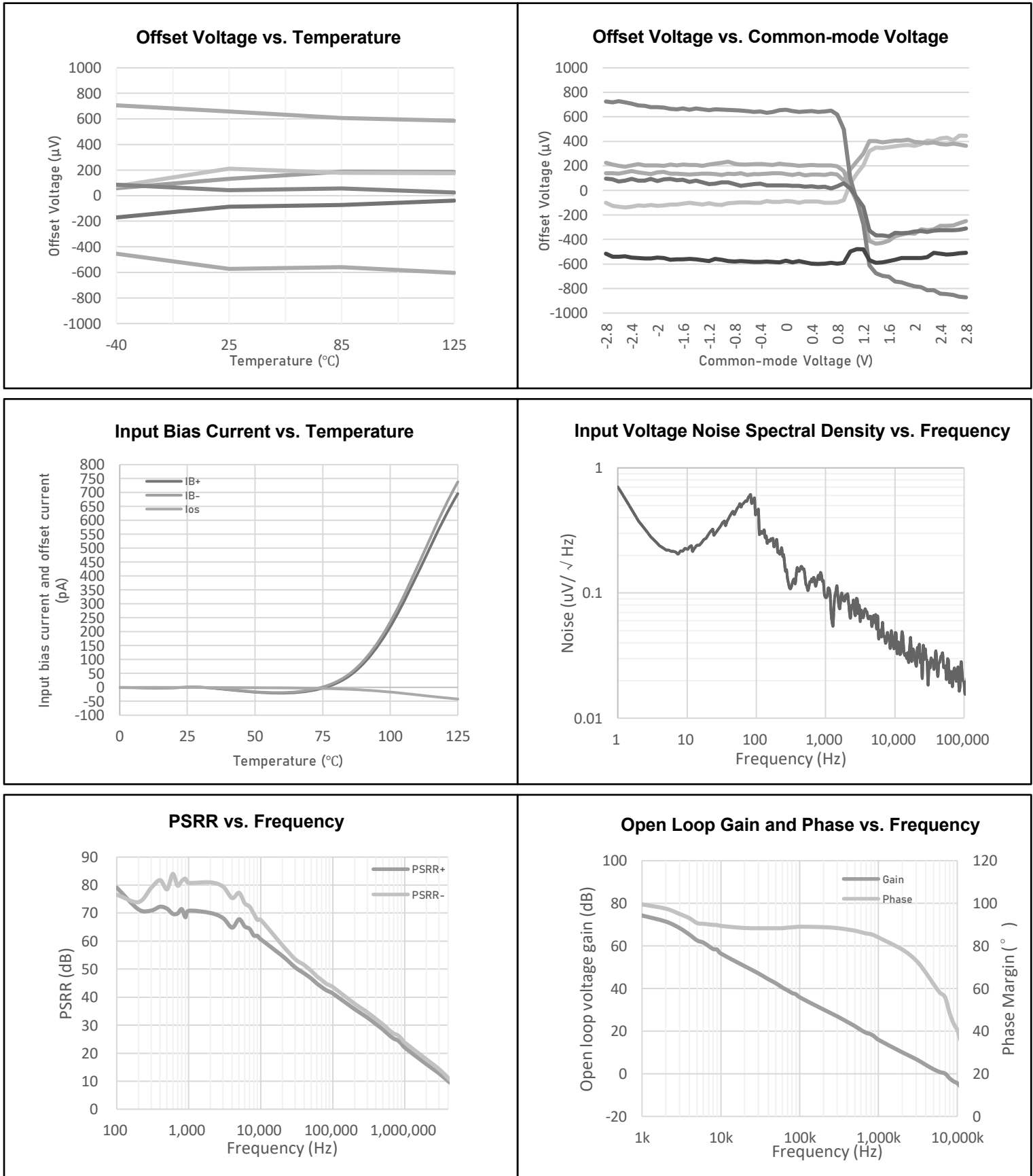

## 7 Specifications

### 7.6 Typical Characteristics

$V_S = 5.0V$ ,  $T_A = +25^\circ C$ ,  $V_{CM} = V_S/2$ ,  $R_L = 10k\Omega$  connected to  $V_S/2$ , unless otherwise noted.

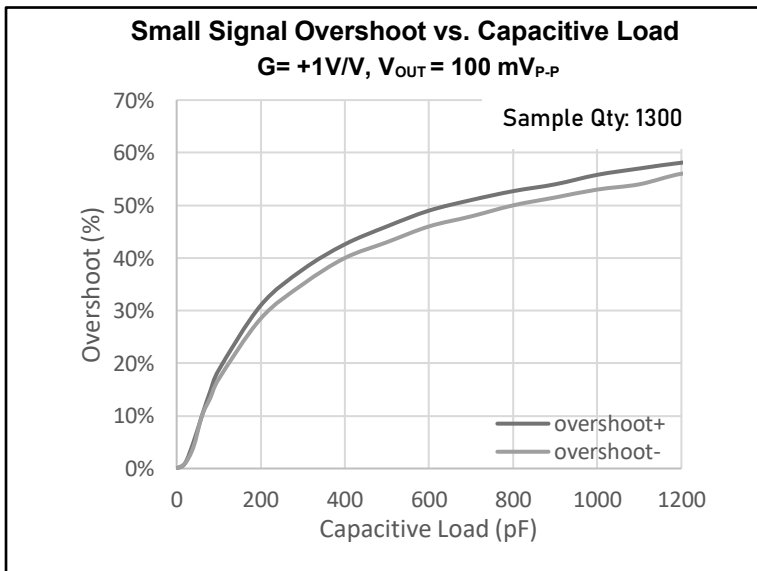
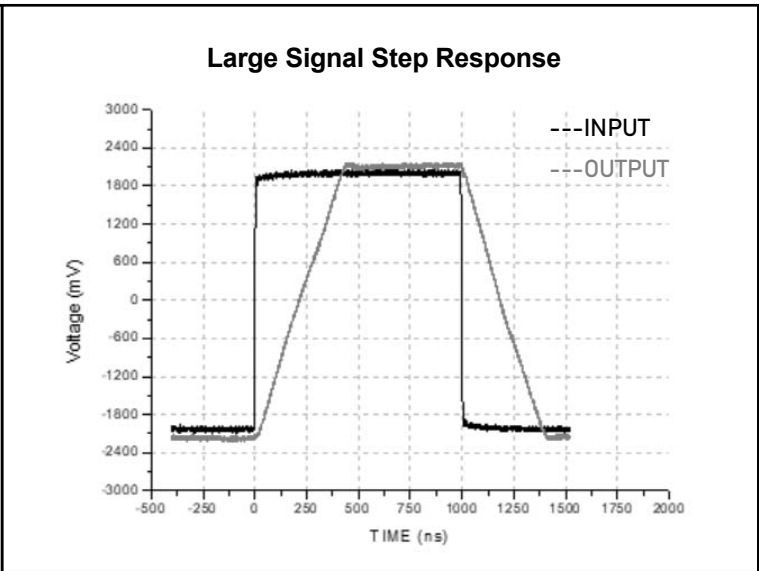
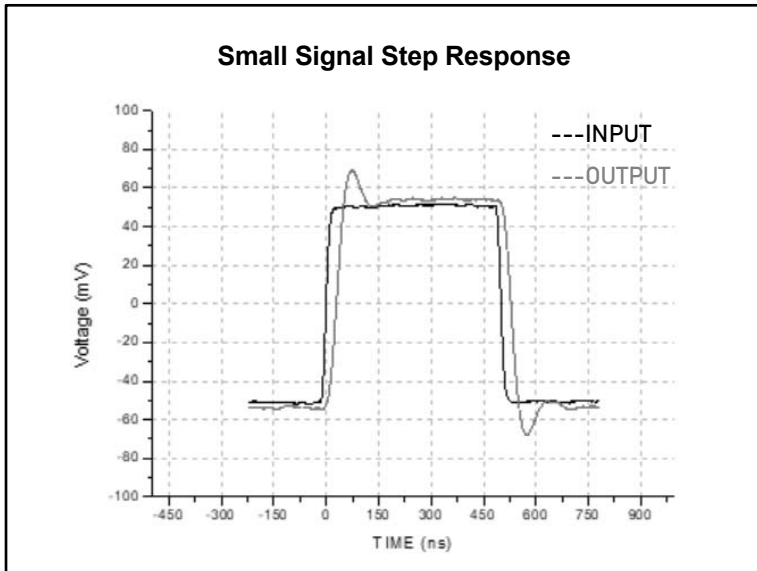
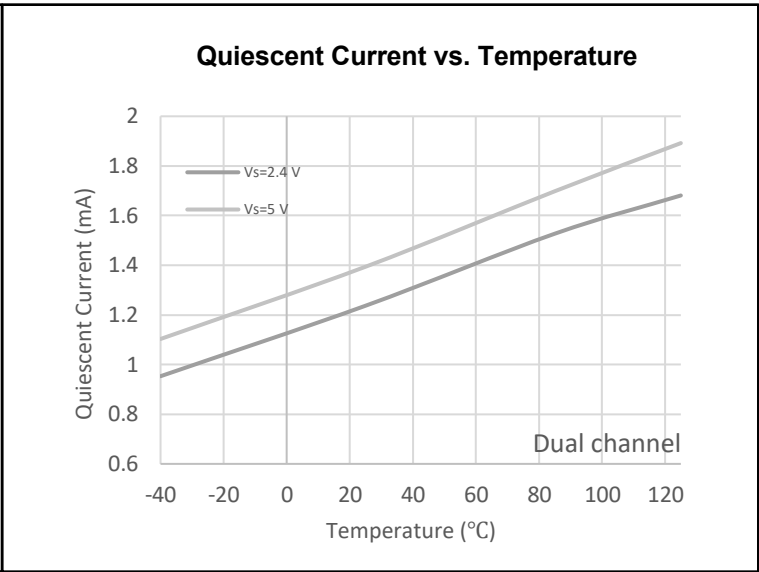
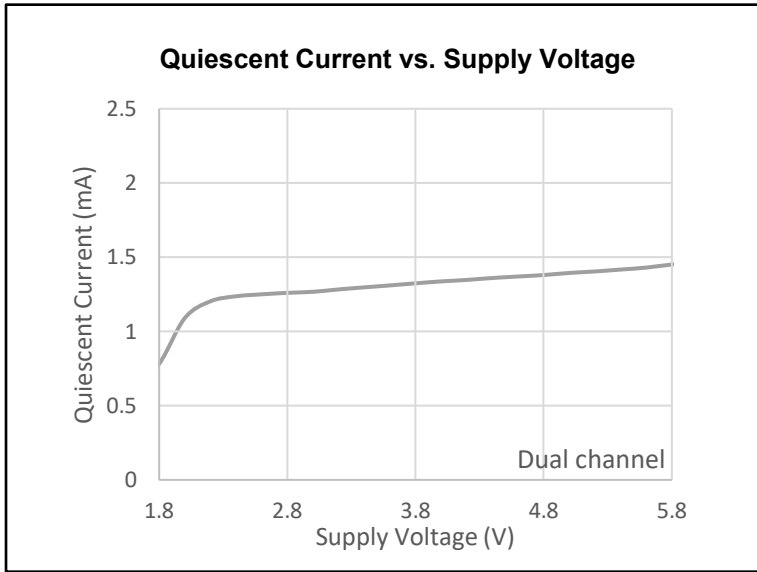

## 8 Detailed Description

### 8.1 Description

The CJOA156x is a family of low-power, rail-to-rail input and output operational amplifiers specifically designed for portable applications. These devices operate from 2.3V to 5.5V at the temperature range of  $-40^{\circ}\text{C}$  to  $+125^{\circ}\text{C}$ , are unity-gain stable, and suitable for a wide range of general-purpose applications. The class AB output stage is capable of driving  $\leq 10\text{k}\Omega$  loads connected to any point between  $V+$  and ground. The input common-mode voltage range includes both rails, and allows the CJOA156x family to be used in virtually any single supply application. Rail-to-rail input and output swing significantly increases dynamic range, especially in low-supply applications, and makes them ideal for driving sampling analog-to-digital converters (ADCs).

### 8.2 Feature Description

#### Rail-to-Rail Input

The input common-mode voltage range of the CJOA156x series extends 100mV beyond the negative and positive supply rails. This performance is achieved with a complementary input stage: an N-channel input differential pair in parallel with a P-channel differential pair. The N-channel pair is active for input voltages close to the positive rail, typically  $(V+) - 1.4\text{V}$  to the positive supply, whereas the P-channel pair is active for inputs from 100mV below the negative supply to approximately  $(V+) - 1.4\text{V}$ . There is a small transition region, typically  $(V+) - 1.2\text{V}$  to  $(V+) - 1\text{V}$ , in which both pairs are on. This 200-mV transition region can vary up to 200mV with process variation. Thus, the transition region (both stages on) can range from  $(V+) - 1.4\text{V}$  to  $(V+) - 1.2\text{V}$  on the low end, up to  $(V+) - 1\text{V}$  to  $(V+) - 0.8\text{V}$  on the high end. Within this transition region, PSRR, CMRR, offset voltage, offset drift, and THD can be degraded compared to device operation outside this region.

The typical input bias current of the CJOA156x during normal operation is approximately 1pA. In overdriven conditions, the bias current can increase significantly. The most common cause of an overdriven condition occurs when the operational amplifier is outside of the linear range of operation. When the output of the operational amplifier is driven to one of the supply rails, the feedback loop requirements cannot be satisfied and a differential input voltage develops across the input pins. This differential input voltage results in activation of parasitic diodes inside the front-end input chopping switches that combine with electromagnetic interference (EMI) filter resistors to create the equivalent circuit. Notice that the input bias current remains within specification in the linear region.

#### Rail-to-Rail Output

Designed as a micro-power, low-noise operational amplifier, the CJOA156x delivers a robust output drive capability. A class AB output stage with common-source transistors is used to achieve full rail-to-rail output swing capability. For resistive loads up to  $100\text{k}\Omega$ , the output swings typically to within 5mV of either supply rail regardless of the power-supply voltage applied. Different load conditions change the ability of the amplifier to swing close to the rails. For resistive loads up to  $600\Omega$ , the output swings typically to within 140mV of the positive supply rail and within 80mV of the negative supply rail.

#### Overload Recovery

Overload recovery is defined as the time required for the operational amplifier output to recover from a saturated state to a linear state. The output devices of the operational amplifier enter a saturation region when the output voltage exceeds the rated operating voltage, either because of the high input voltage or the high gain. After the device enters the saturation region, the charge carriers in the output device require time to return back to the linear state. After the charge carriers return back to the linear state, the device begins to slew at the specified slew rate. Thus, the propagation delay in case of an overload condition is the sum of the overload recovery time and the slew time. The overload recovery time for the CJOA156x family is approximately 0.3 $\mu\text{s}$ .

## 8 Detail Description

### 8.2 Feature Description (continued)

#### EMI Rejection

Circuit performance is often adversely affected by high frequency EMI. When the signal strength is low and transmission lines are long, an op-amp must accurately amplify the input signals. However, all op-amp pins — the non-inverting input, inverting input, positive supply, negative supply, and output pins — are susceptible to EMI signals. These high frequency signals are coupled into an op-amp by various means, such as conduction, near field radiation, or far field radiation. For example, wires and printed circuit board (PCB) traces can act as antennas and pick up high frequency EMI signals.

Amplifiers do not amplify EMI or RF signals due to their relatively low bandwidth. However, due to the nonlinearities of the input devices, op-amps can rectify these out of band signals. When these high frequency signals are rectified, they appear as a dc offset at the output.

The CJOA156x op-amps have integrated EMI filters at their input stage. A mathematical method of measuring EMIRR is defined as follows:

$$EMIRR = 20 \log(V_{IN\_PEAK} / \Delta V_{OS})$$

## 9 Application and Implementation

### 9.1 Application Information

The CJOA156x features 7MHz bandwidth and 10V/ $\mu$ s slew rate with only 700 $\mu$ A supply current per amplifier, providing good ac performance at very low power consumption. DC applications are also well served with low input bias current, and an input offset voltage of 0.7mV typically. The typical offset voltage drift is 1 $\mu$ V/ $^{\circ}$ C, over the full temperature range the input offset voltage changes only 100 $\mu$ V (0.7mV to 0.8mV).

### 9.2 Typical Application Circuits

#### Input EMI Filter and Clamp Circuit

Figure 9-1 shows the input EMI filter and clamp circuit. The CJOA156x op-amps have internal ESD protection diodes (D1, D2, D3, and D4) that are connected between the inputs and each supply rail. These diodes protect the input transistors in the event of electrostatic discharge and are reverse biased during normal operation. This protection scheme allows voltages as high as approximately 500mV beyond the rails to be applied at the input of either terminal without causing permanent damage. These ESD protection current-steering diodes also provide in-circuit, input overdrive protection, as long as the current is limited to 20mA as stated in the Absolute Maximum Ratings.

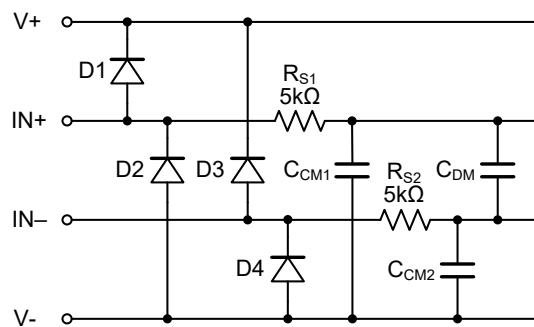

Figure 9-1. Input EMI Filter and Clamp Circuit

Operational amplifiers vary in susceptibility to EMI. If conducted EMI enters the operational amplifier, the dc offset at the amplifier output can shift from its nominal value when EMI is present. This shift is a result of signal rectification associated with the internal semiconductor junctions. Although all operational amplifier pin functions can be affected by EMI, the input pins are likely to be the most susceptible. The EMI filter of the CJOA156x family is composed of two 5k $\Omega$  input series resistors ( $R_{S1}$  and  $R_{S2}$ ), two common-mode capacitors ( $C_{CM1}$  and  $C_{CM2}$ ), and a differential capacitor ( $C_{DM}$ ). These RC networks set the -3dB low-pass cutoff frequencies at 35MHz for common-mode signals, and at 22MHz for differential signals.

#### Input-to-Output Coupling

To minimize capacitive coupling, the input and output signal traces should not be parallel. This helps reduce unwanted positive feedback.

## 9 Application and Implementation

### 9.2 Typical Application Circuits (continued)

#### Capacitive Load and Stability

As with most amplifiers, driving larger capacitive loads than specified may cause excessive overshoot and ringing, or even oscillation. A heavy capacitive load reduces the phase margin and causes the amplifier frequency response to peak. Peaking corresponds to overshooting or ringing in the time domain. Therefore, it is recommended that external compensation be used if the CJOA156x op-amps must drive a heavy capacitive load. This compensation is particularly important in the unity-gain configuration, which is the worst case for stability. A quick and easy way to stabilize the op-amp for capacitive load drive is by adding a series resistor,  $R_{ISO}$ , between the amplifier output terminal and the load capacitance, as shown in Figure 9-2.  $R_{ISO}$  isolates the amplifier output and feedback network from the capacitive load. The bigger the  $R_{ISO}$  resistor value, the more stable  $V_{OUT}$  will be. Note that this method results in a loss of gain accuracy because  $R_{ISO}$  forms a voltage divider with the  $R_L$ .

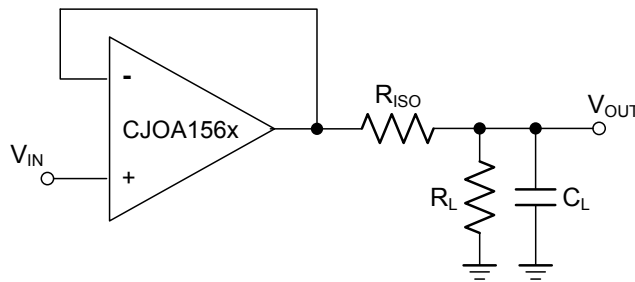

Figure 9-2. Indirectly Driving Heavy Capacitive Load

An improvement circuit is shown in Figure 9-3. It provides DC accuracy as well as AC stability. The  $R_F$  provides the DC accuracy by connecting the inverting signal with the output.

The  $C_F$  and  $R_{ISO}$  serve to counteract the loss of phase margin by feeding the high frequency component of the output signal back to the amplifier's inverting input, thereby preserving phase margin in the overall feedback loop. For no-buffer configuration, there are two other ways to increase the phase margin: (a) by increasing the amplifier's gain, or (b) by placing a capacitor in parallel with the feedback resistor to counteract the parasitic capacitance associated with inverting node.

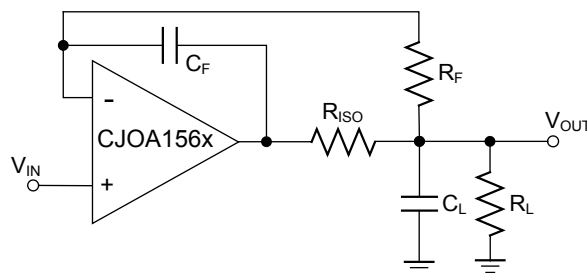

Figure 9-3. Indirectly Driving Heavy Capacitive Load with DC Accuracy

## 9 Application and Implementation

### 9.2 Typical Application Circuits (continued)

#### Active filter

The CJOA156x family is well-suited for active filter applications that require a wide bandwidth, fast slew rate, single-supply operational amplifier. Figure 9-4 shows a 500kHz, second-order, low-pass filter using the multiple-feedback (MFB) topology. The components have been selected to provide a maximally-flat Butterworth response. Beyond the cut-off frequency, roll-off is  $-40\text{dB/dec}$ . The Butterworth response is ideal for applications that require predictable gain characteristics, such as the anti-aliasing filter used in front of an ADC.

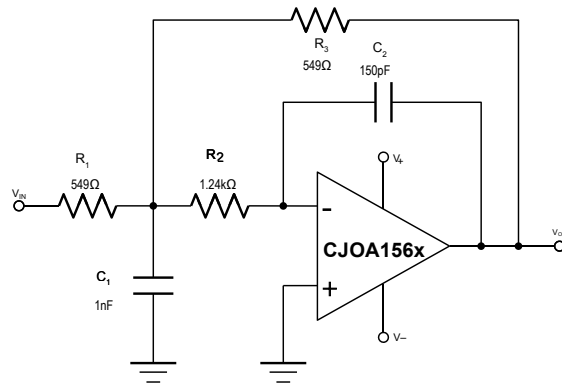

Figure 9-4. Second-Order, Butterworth, 500kHz Low-Pass Filter

One point to observe when considering the MFB filter is that the output is inverted, relative to the input. If this inversion is not required, or not desired, a non-inverting output can be achieved through one of these options:

1. adding an inverting amplifier;
2. adding an additional second-order MFB stage;
3. using a non-inverting filter topology, such as the Sallen-Key (shown in Figure 9-5).

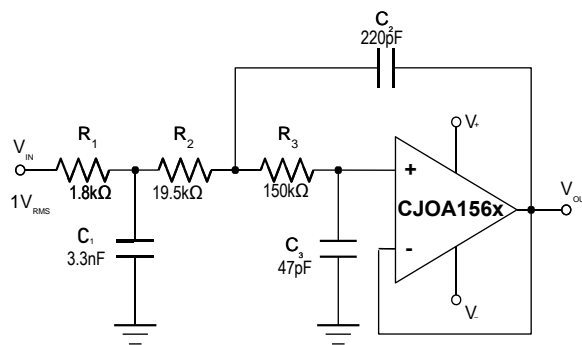

Figure 9-5. Configured as a Three-Pole, 20kHz, Sallen-Key Filter

#### Motor Phase Current Sensing

The current sensing amplification shown in Figure 9-6 has a slew rate of  $2\pi V_{PP}$  for the output of sine wave signal, and has a slew rate of  $2V_{PP}$  for the output of triangular wave signal. In most of motor control systems, the PWM frequency is at 10kHz to 20kHz, and one cycle time is 100μs for a 10kHz of PWM frequency. In current shunt monitoring for a motor phase, the phase current is converted to a phase voltage signal for ADC sampling. This sampling voltage signal must be settled before entering the ADC. As the Figure 9-6 shown, the total settling time of a current shunt monitor circuit includes: the rising edge delay time ( $t_{SR}$ ) due to the op-amp's slew rate, and the measurement settling time ( $t_{SET}$ ). For a 2-shunt solution of motor phase current sensing, if the minimum duty cycle of the PWM is defined at 5%, and the  $t_{SR}$  is required at 20% of a total time window for a phase current monitoring,

## 9 Application and Implementation

### 9.2 Typical Application Circuits (continued)

#### Motor Phase Current Sensing (continued)

in case of a 3.3V motor control system (3.3V MCU with 12-bit ADC), the op-amp's slew rate should be more than:

$$\frac{3.3V}{(100\mu s \times 5\% \times 20\%)} = 3.3/\mu s$$

At the same time, the op-amp's bandwidth should be much greater than the PWM frequency, like 10 time at least.

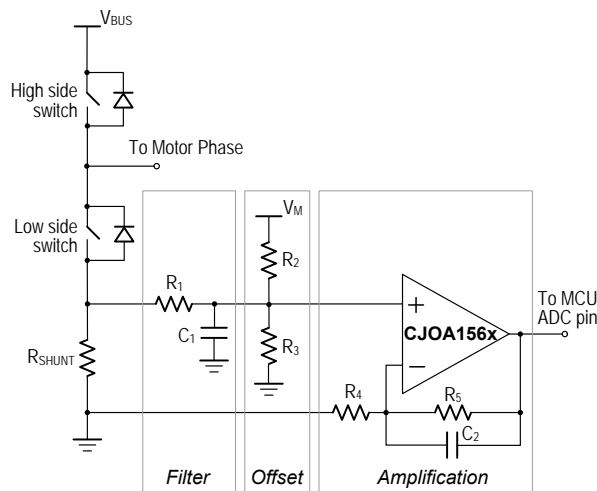
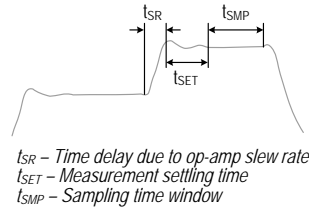

Figure 9-6. Current Shunt Monitor Circuit

#### Differential Amplifier

The circuit shown in Figure 9-7 performs the difference function. If the resistors ratios are equal  $R_4/R_3 = R_2/R_1$ , then:

$$V_{OUT} = (V_p - V_n) \times R_2/R_1 + V_{REF}$$

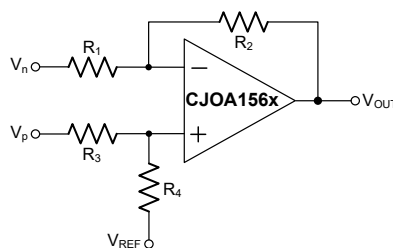

Figure 9-7. Differential Amplifier

## 9 Application and Implementation

### 9.2 Typical Application Circuits (continued)

#### Instrumentation Amplifier

The CJOA156x family is well suited for conditioning sensor signals in battery-powered applications. Figure 9-8 shows a two op-amp instrumentation amplifier, using the CJOA156x op-amps. The circuit works well for applications requiring rejection of common-mode noise at higher gains. The reference voltage ( $V_{REF}$ ) is supplied by a low-impedance source. In single voltage supply applications, the  $V_{REF}$  is typically  $V_S/2$ .

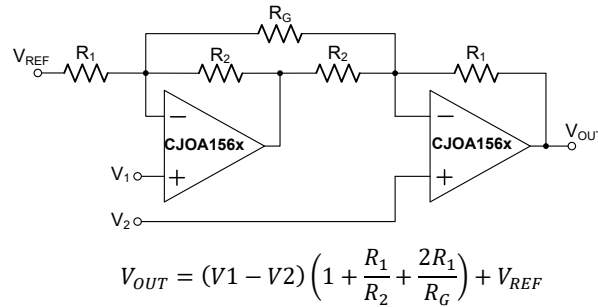

Figure 9-8. Instrumentation Amplifier

#### Buffered Chemical Sensors

The CJOA156x family has input bias current in the pA range. This is ideal in buffering high impedance chemical sensors, such as pH probes. As an example, the circuit in Figure 9-9 eliminates expensive low-leakage cables that that is required to connect a pH probe (general purpose combination pH probes, e.g Corning 476540) to metering ICs such as ADC, AFE and/or MCU. A CJOA156x op-amp and a lithium battery are housed in the probe assembly. A conventional low-cost coaxial cable can be used to carry the op-amp's output signal to subsequent ICs for pH reading.

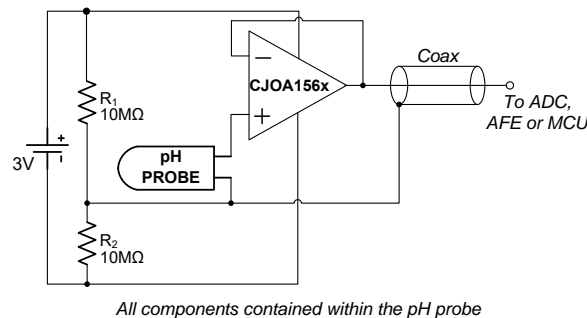

Figure 9-9. Buffered pH Probe

### 9.3 Power Supply Recommendations

The CJOA156x family is optimized for operation at voltages as low as +2.3V ( $\pm 1.15V$ ) and up to +5.5V ( $\pm 2.75V$ ). In addition, many specifications apply from  $-40^{\circ}C$  to  $+125^{\circ}C$ . Parameters that vary significantly with operating voltages or temperature are illustrated in the Typical Characteristics graphs.

NOTE: Supply voltages ( $V+$  to  $V-$ ) higher than +10V can permanently damage the device.

## 9 Application and Implementation

### 9.4 Layout Guidelines

To achieve the maximum performance of the extremely high input impedance and low offset voltage of the CJOA156x op-amps, care is needed in laying out the circuit board. The PCB surface must remain clean and free of moisture to avoid leakage currents between adjacent traces. Surface coating of the circuit board reduces surface moisture and provides a humidity barrier, reducing parasitic resistance on the board. The use of guard rings around the amplifier inputs further reduces leakage currents. Figure 9-10 shows proper guard ring configuration and the top view of a surface-mount layout. The guard ring does not need to be a specific width, but it should form a continuous loop around both inputs. By setting the guard ring voltage equal to the voltage at the non-inverting input, parasitic capacitance is minimized as well. For further reduction of leakage currents, components can be mounted to the PCB using Teflon standoff insulators.

Other potential sources of offset error are thermoelectric voltages on the circuit board. This voltage, also called Seebeck voltage, occurs at the junction of two dissimilar metals and is proportional to the temperature of the junction. The most common metallic junctions on a circuit board are solder-to-board trace and solder-to-component lead. If the temperature of the PCB at one end of the component is different from the temperature at the other end, the resulting Seebeck voltages are not equal, resulting in a thermal voltage error.

This thermocouple error can be reduced by using dummy components to match the thermoelectric error source. Placing the dummy component as close as possible to its partner ensures both Seebeck voltages are equal, thus canceling the thermocouple error. Maintaining a constant ambient temperature on the circuit board further reduces this error. The use of a ground plane helps distribute heat throughout the board and reduces EMI noise pickup.

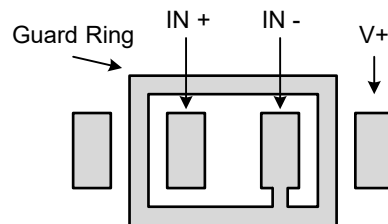
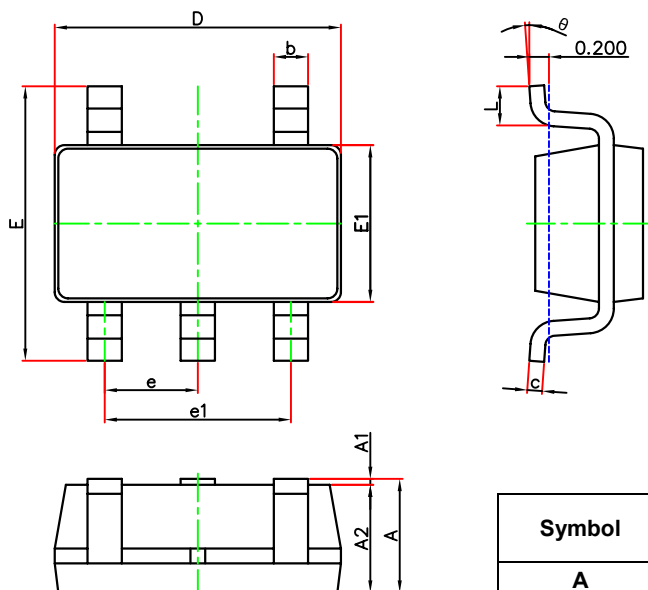

Figure 9-10. Guard Ring

10 Mechanical Information

10.1 SOT-23-5L Mechanical Information

SOT-23-5L Outline Dimensions



Symbol	Dimensions In Millimeters		Dimensions In Inches	
	Min.	Max.	Min.	Max.
A	1.050	1.250	0.041	0.049
A1	0.000	0.100	0.000	0.004
A2	1.000	1.200	0.039	0.047
b	0.300	0.500	0.012	0.020
c	0.100	0.200	0.004	0.008
D	2.820	3.020	0.111	0.119
E	2.600	3.000	0.102	0.118
E1	1.500	1.700	0.059	0.067
e	0.950(BSC)		0.037(BSC)	
e1	1.800	2.000	0.071	0.079
L	0.300	0.600	0.012	0.024
theta	0°	8°	0°	8°

SOT-23-5L Suggested Pad Layout

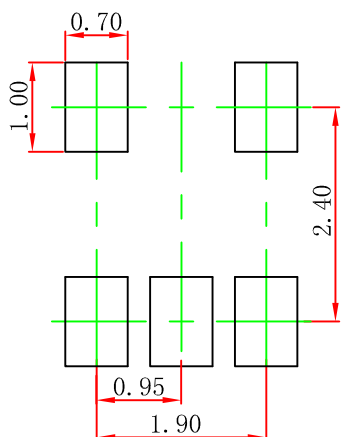

Note:

1. Controlling dimension: in millimeters.
2. General tolerance: ±0.05mm.
3. The pad layout is for reference purpose only.

## 10 Mechanical Information

### 10.2 SOP8 Mechanical Information

#### Outline Dimensions

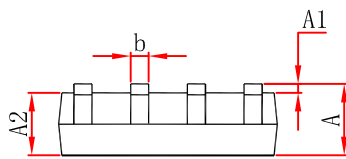
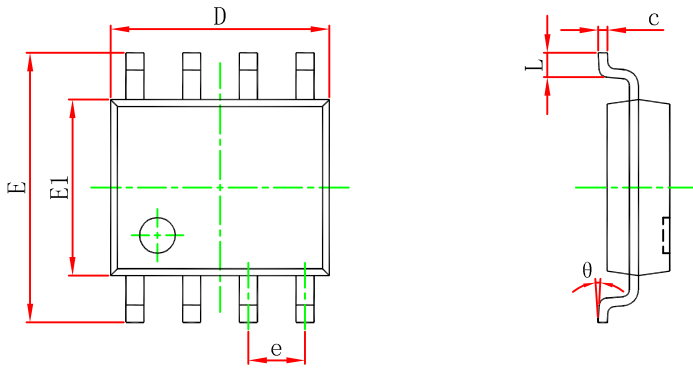

Symbol	Dimensions In Millimeters		Dimensions In Inches	
	Min	Max	Min	Max
A	1.450	1.750	0.053	0.069
A1	0.100	0.250	0.004	0.010
A2	1.350	1.550	0.053	0.061
b	0.330	0.510	0.013	0.020
c	0.170	0.250	0.007	0.010
D	4.700	5.100	0.185	0.201
e	1.270 (BSC)		0.050 (BSC)	
E	5.800	6.200	0.228	0.244
E1	3.800	4.000	0.150	0.157
L	0.400	1.270	0.016	0.050
theta	0°	8°	0°	8°

#### SOP8 Suggest Pad Layout

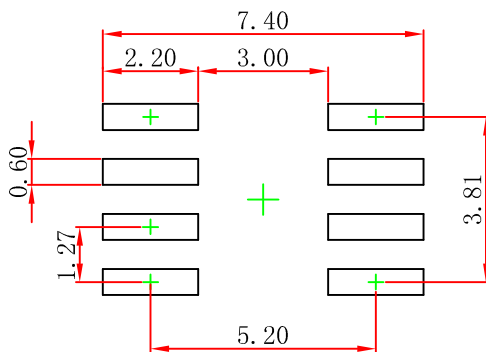

#### NOTE:

1. Controlling dimension: in millimeters.
2. General tolerance:  $\pm 0.05\text{mm}$ .
3. The pad layout is for reference purposes only.

10 Mechanical Information

10.3 MSOP8 Mechanical Information

Outline Dimensions

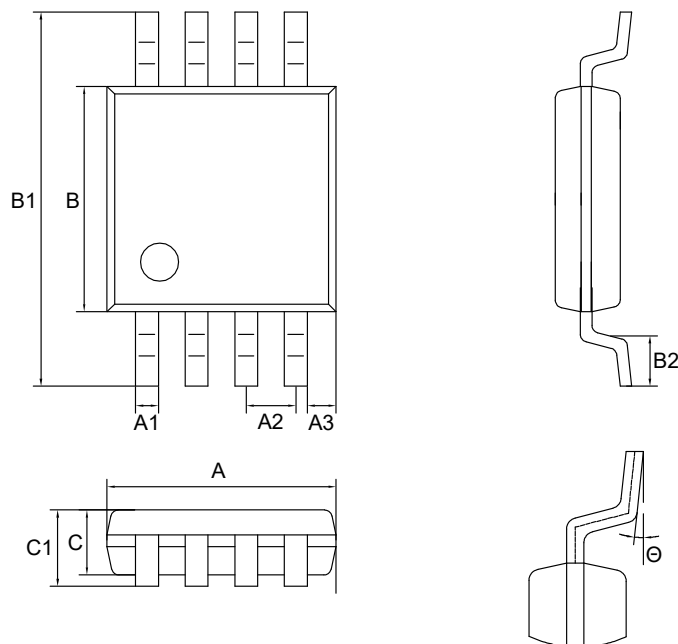

SYMBOL	DISMENSIONS IN MILLIMETERS			DISMENSIONS IN INCHES		
	MIN	NOM	MAX	MIN	NOM	MAX
A	2.900	3.000	3.100	0.114	0.118	0.122
A1	0.280	-	0.350	0.011	-	0.014
A2	0.650 TYP.			0.026 TYP.		
B	2.900	3.000	3.100	0.114	0.118	0.122
B1	4.700	-	5.100	0.185	-	0.201
B2	0.450	0.600	0.750	0.018	0.024	0.030
C	0.750	0.850	0.950	0.030	0.033	0.037
C1	-	-	1.100	-	-	0.043
Θ	0°	-	6°	0°	-	6°

10 Mechanical Information

10.4 DFNWB2×2-8L Mechanical Information

Outline Dimensions

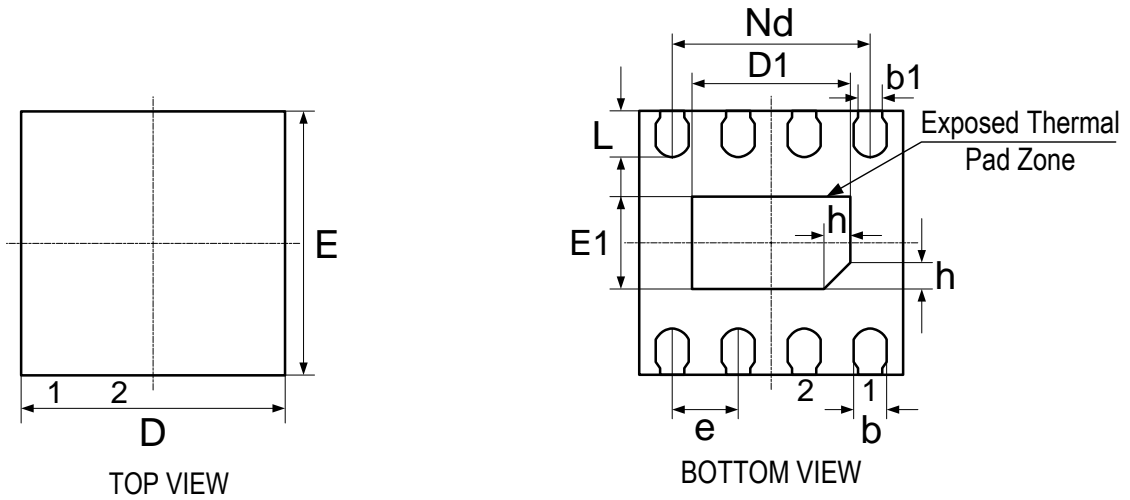

SYMBOL	DISMENSIONS IN MILLIMETERS			DISMENSIONS IN INCHES		
	MIN	NOM	MAX	MIN	NOM	MAX
A	0.700	0.750	0.800	0.028	0.030	0.031
A1	-	0.020	0.050	-	0.001	0.002
b	0.200	0.250	0.300	0.008	0.010	0.012
b1	0.180 Bsc.			0.007 Bsc.		
c	0.180	0.200	0.250	0.007	0.008	0.010
D	1.900	2.000	2.100	0.075	0.079	0.083
D2	1.100	1.200	1.300	0.043	0.047	0.051
Nd	1.500 Bsc.			0.059 Bsc.		
E	1.900	2.000	2.100	0.075	0.079	0.083
E1	0.600	0.700	0.800	0.024	0.028	0.031
e	0.500 Bsc.			0.020 Bsc.		
L	0.300	0.350	0.400	0.012	0.014	0.016
h	0.150	0.200	0.250	0.006	0.008	0.010

DFNWB2×2-8L Suggest Pad Layout

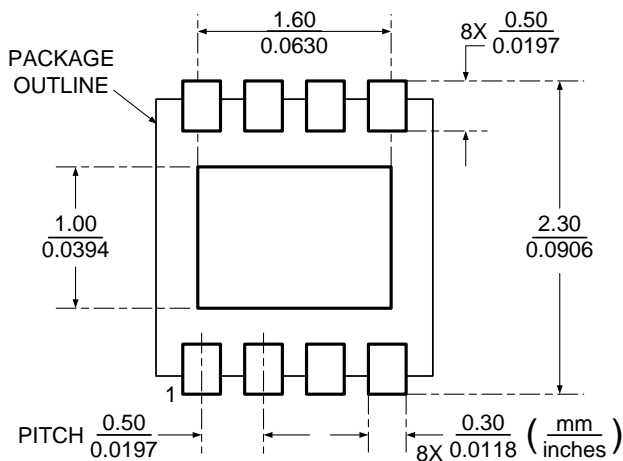

NOTE:

- Controlling dimension: in millimeters.
- General tolerance:  $\pm 0.05$ mm.
- The pad layout is for reference purposes only.

10 Mechanical Information

10.5 SOP14 Mechanical Information

Outline Dimensions

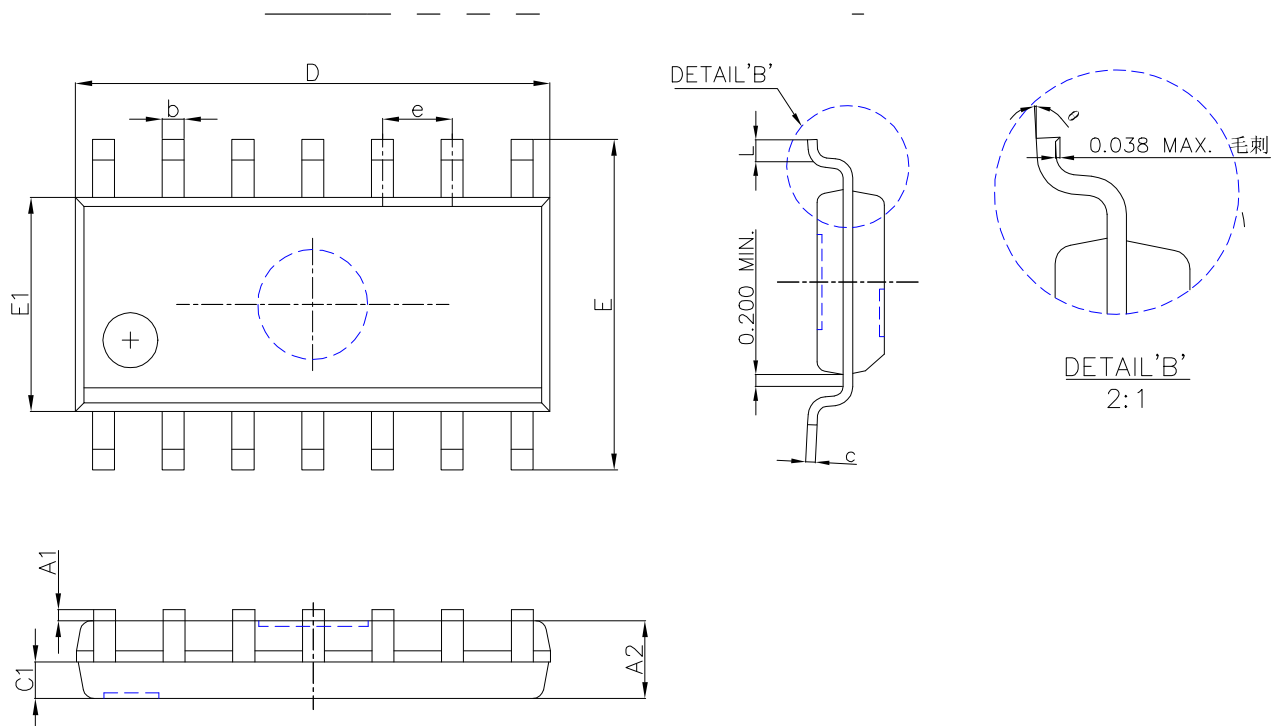

SYMBOL	DISMENSIONS IN MILLIMETERS			DISMENSIONS IN INCHES		
	MIN	NOM	MAX	MIN	NOM	MAX
D	8.630	8.730	8.830	0.340	0.344	0.348
b	0.406 Typ.			0.016 Typ.		
e	1.270 Typ.			0.050 Typ.		
E1	3.850	3.950	4.050	0.152	0.155	0.159
E	5.840	6.040	6.240	0.230	0.238	0.246
A2	1.350	1.450	1.550	0.053	0.057	0.061
C1	0.550	0.650	0.750	0.022	0.026	0.030
A1	0.100	0.200	0.300	0.004	0.008	0.012
c	0.203 Typ.			0.008 Typ.		
L	0.350	0.550	0.750	0.014	0.022	0.030
θ	0°	2°	8°	0°	2°	8°

10 Mechanical Information

10.6 TSSOP14 Mechanical Information

Outline Dimensions

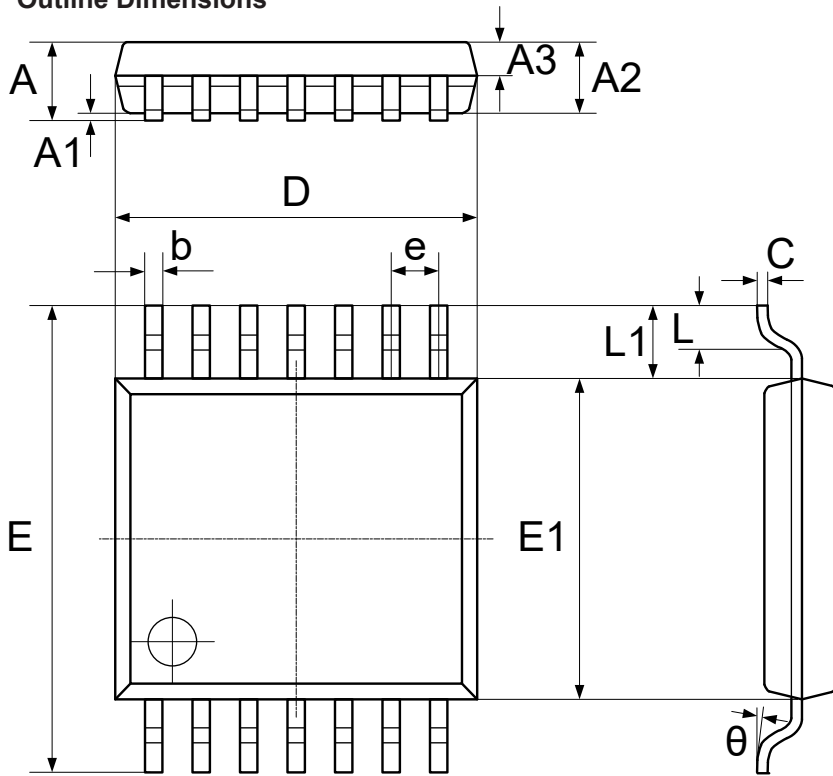

Symbol	Dimensions In Millimeters		Dimensions In Inches	
	Min	Max	Min	Max
A	-	1.200	-	0.047
A1	0.050	0.150	0.002	0.006
A2	0.900	1.050	0.035	0.041
A3	0.390	0.490	0.015	0.019
b	0.200	0.290	0.008	0.011
C	0.130	0.180	0.005	0.007
D	4.860	5.060	0.191	0.199
E	6.200	6.600	0.244	0.260
E1	4.300	4.500	0.169	0.177
e	0.650 TYP.		0.026 TYP.	
L1	1.000 REF.		0.039 REF.	
L	0.450	0.750	0.018	0.030
theta	0°	8°	0°	8°

TSSOP14 Suggest Pad Layout

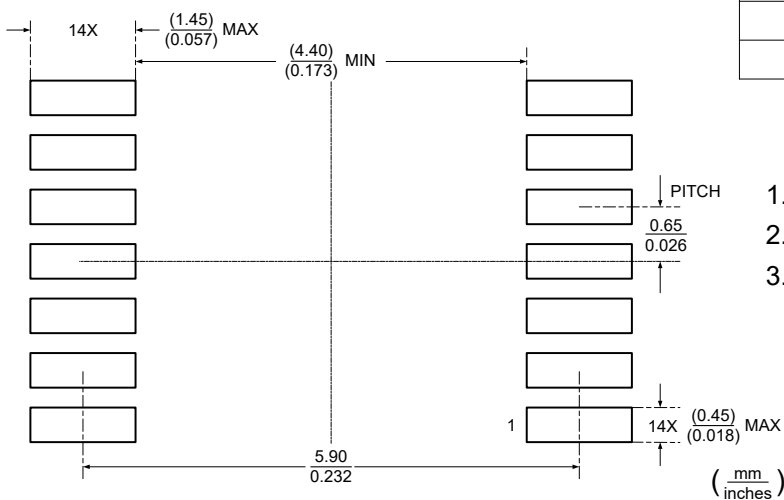

NOTE:

1. Controlling dimension: in millimeters.
2. General tolerance: ±0.05mm.
3. The pad layout is for reference purposes only.

# 11 Packaging Information

## 11.1 SOT-23-5L Tape and Reel Information

### SOT-23-5L Tape and Reel Information

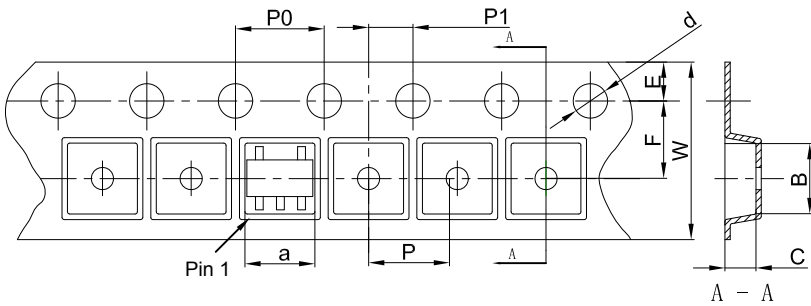

**Packaging Description:**

SOT-23-5L parts are shipped in tape. The carrier tape is made from a dissipative (carbon filled) polycarbonate resin. The cover tape is a multilayer film (Heat Activated Adhesive in nature) primarily composed of polyester film, adhesive layer, sealant, and anti-static sprayed agent. These reeled parts in standard option are shipped with 3,000 units per 7" or 18.0cm diameter reel. The reels are clear in color and is made of polystyrene plastic (anti-static coated).

Dimensions are in millimeter										
Pkg type	a	B	C	d	E	F	P0	P	P1	W
SOT-23-5L	3.17	3.23	1.37	Ø1.55	1.75	3.50	4.00	4.00	2.00	8.00

### SOT-23-5L Tape Leader and Trailer

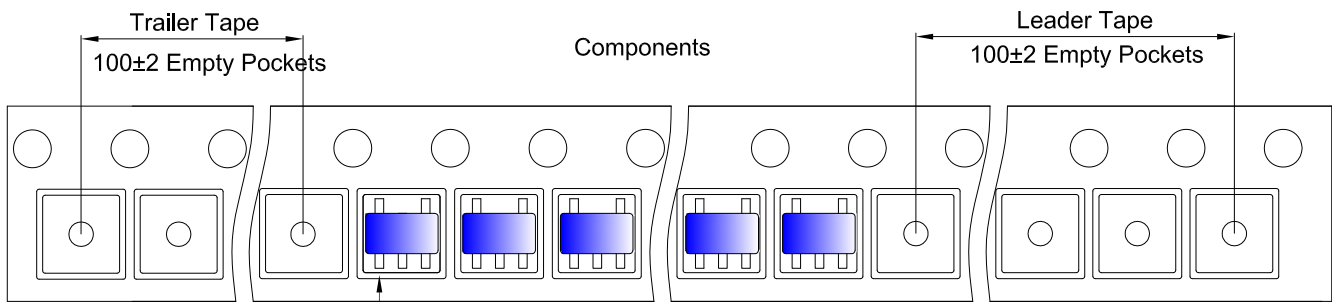

### SOT-23-5L Reel

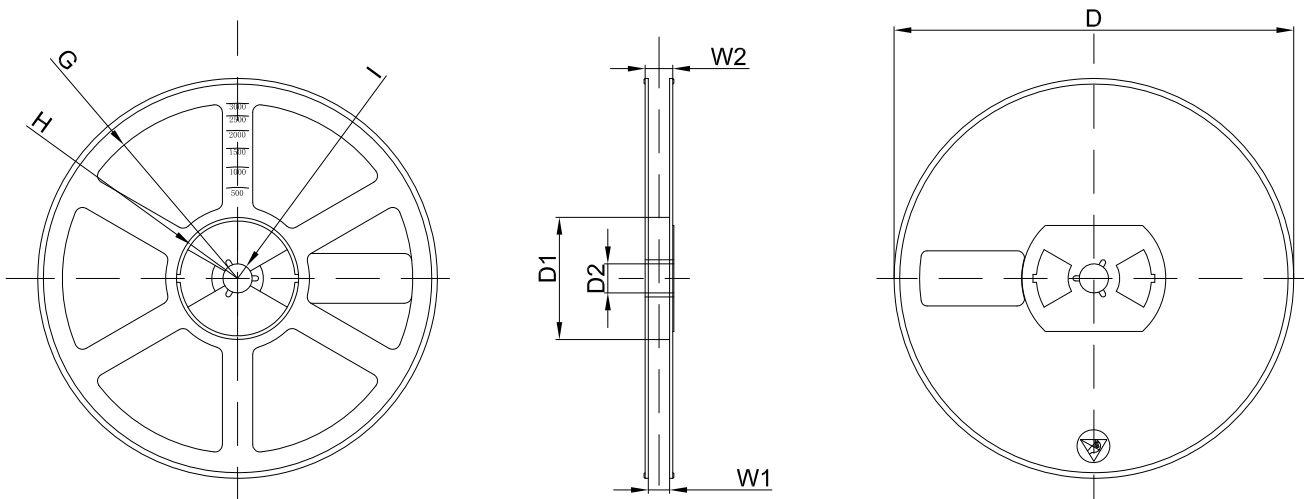

Dimensions are in millimeter								
Reel Option	D	D1	D2	G	H	I	W1	W2
7" Dia	Ø180.00	60.00	13.00	R78.00	R25.60	R6.50	9.50	13.10

REEL	Reel Size	Box	Box Size(mm)	Carton	Carton Size(mm)	G.W.(kg)
3000 pcs	7 inch	30,000 pcs	203×203×195	120,000 pcs	438×438×220	

# 11 Packaging Information

## 11.2 SOP8 Tape and Reel Information

### Embossed Carrier Tape

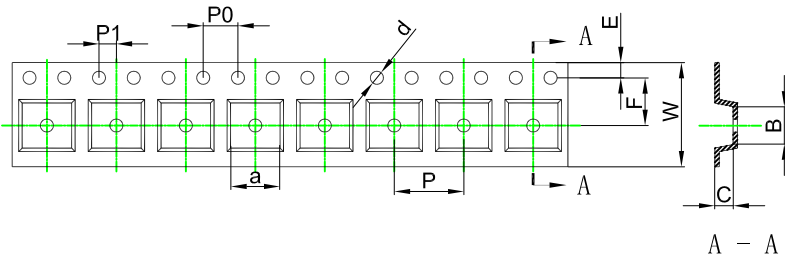

**Packaging Description:**

SOP8 parts are shipped in tape. The carrier tape is made from a dissipative (carbon filled) polycarbonate resin. The cover tape is a multilayer film (Heat Activated Adhesive in nature) primarily composed of polyester film, adhesive layer, sealant, and anti-static sprayed agent. These reeled parts in standard option are shipped with 2,500 units per 13" or 33cm diameter reel. The reels are clear in color and is made of polystyrene plastic (anti-static coated).  
**ALL DIM IN mm**

Dimensions are in millimeter										
Pkg type	a	B	C	d	E	F	P0	P	P1	W
SOP8	6.40	5.40	2.10	Ø1.50	1.75	5.50	4.00	8.00	2.00	12.00

### Tape Leader and Trailer

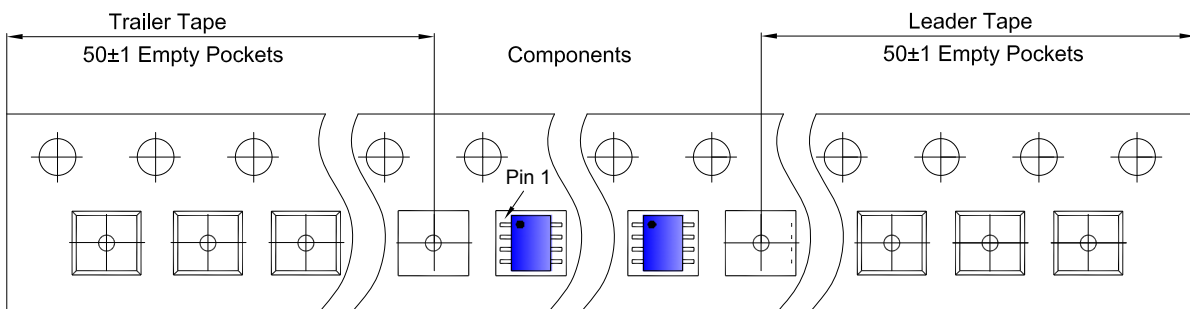

### Reel

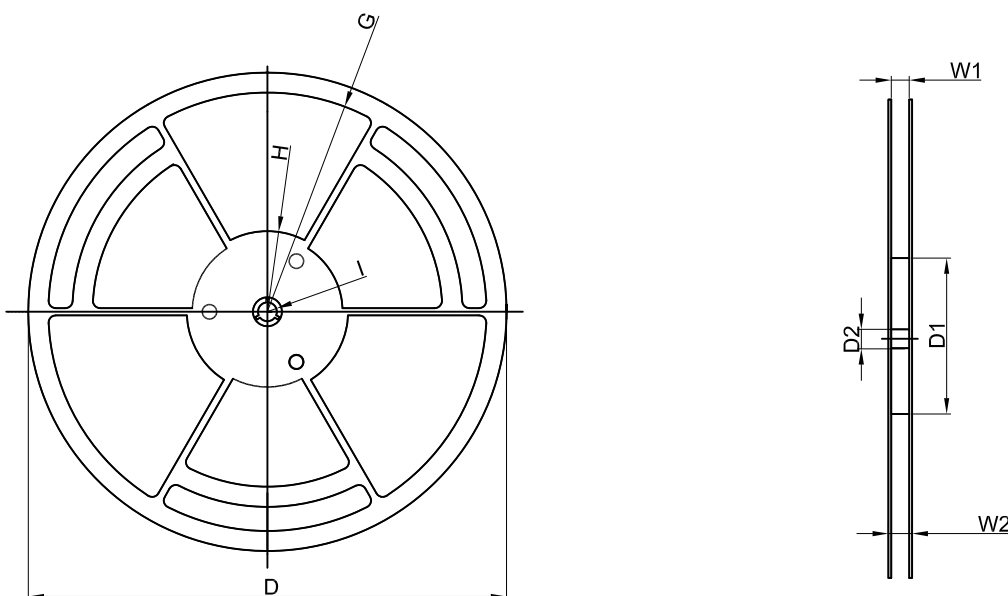

Dimensions are in millimeter								
Reel Option	D	D1	D2	G	H	I	W1	W2
13" Dia	Ø330.00	100.00	13.00	R151.00	R56.00	R6.50	12.40	17.60

REEL	Reel Size	Box	Box Size(mm)	Carton	Carton Size(mm)	G.W.(kg)
4,000 pcs	13 inch	8,000 pcs	360×360×65	64,000 pcs	565×380×390	

## 12 Notes and Revision History

### 12.1 Associated Product Family and Others

To view other products of the same type or IC products of other types, click the official website of JSCJ -- <https://www.jscj-elec.com> for more details.

### 12.2 Notes

#### Electrostatic Discharge Caution



This IC may be damaged by ESD. Relevant personnel shall comply with correct installation and use specifications to avoid ESD damage to the IC. If appropriate measures are not taken to prevent ESD damage, the hazards caused by ESD include but are not limited to degradation of integrated circuit performance or complete damage of integrated circuit. For some precision integrated circuits, a very small parameter change may cause the whole device to be inconsistent with its published specifications.

### 12.3 Revision History

**October 2025:** changed from rev - 1.0 to rev - 1.1: Added LMV324B-PIN for TSSOP14 package in the datasheet.

**February 2025:** released CJOA156x Series rev - 1.0.

# DISCLAIMER

## **IMPORTANT NOTICE, PLEASE READ CAREFULLY**

The information in this data sheet is intended to describe the operation and characteristics of our products. JSCJ has the right to make any modification, enhancement, improvement, correction or other changes to any content in this data sheet, including but not limited to specification parameters, circuit design and application information, without prior notice.

Any person who purchases or uses JSCJ products for design shall: 1. Select products suitable for circuit application and design; 2. Design, verify and test the rationality of circuit design; 3. Procedures to ensure that the design complies with relevant laws and regulations and the requirements of such laws and regulations. JSCJ makes no warranty or representation as to the accuracy or completeness of the information contained in this data sheet and assumes no responsibility for the application or use of any of the products described in this data sheet.

Without the written consent of JSCJ, this product shall not be used in occasions requiring high quality or high reliability, including but not limited to the following occasions: medical equipment, military facilities and aerospace. JSCJ shall not be responsible for casualties or property losses caused by abnormal use or application of this product.

Official Website: [www.jscj-elec.com](http://www.jscj-elec.com)

Copyright © JIANGSU CHANGJING ELECTRONICS TECHNOLOGY CO., LTD.