

**TO-220-3L-CB Plastic-Encapsulate MOSFET**

**CJP016SN15MK** N-Channel Power MOSFET

**Key Performance Parameters**

|                            |                              |                      |
|----------------------------|------------------------------|----------------------|
| <b>V<sub>BR(DSS)</sub></b> | <b>R<sub>DS(on)TYP</sub></b> | <b>I<sub>D</sub></b> |
| <b>150V</b>                | <b>13mΩ@10V</b>              | <b>76A</b>           |

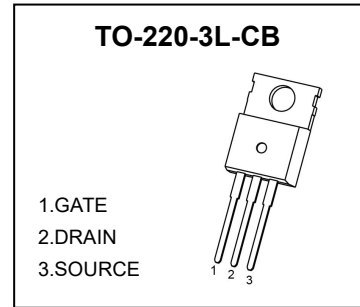

**DESCRIPTION**

The N-Channel enhancement mode power field effect transistors is using SGT technology. This advanced technology has been especially tailored to minimize on-state resistance, provide superior switching performance, and withstand high energy pulse in the avalanche and commutation mode. These devices are well suited for high efficiency fast switching applications.

**FEATURES**

- 100% Avalanche tested
- Low drain-source on-resistance
- Low gate charge
- High current capability

**APPLICATIONS**

- DC/DC
- Switching application

**MARKING**

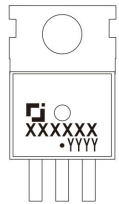

XXXXXX = 016SN15MK  
 Solid dot = Green molding compound device.  
 YYYYY = Code.

**EQUIVALENT CIRCUIT**

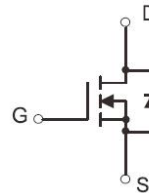

**ABSOLUTE MAXIMUM RATINGS ( T<sub>J</sub>=25°C unless otherwise specified )**

| Parameter  | Symbol                            | Value                 | Unit |
|--|-----------------------------------|-----------------------|------|
| Drain-Source Voltage                             | V <sub>DS</sub>                   | 150                   | V    |
| Gate-Source Voltage                              | V <sub>GS</sub>                   | ±20                   | V    |
| Continuous Drain Current                         | I <sub>D</sub>                    | T <sub>C</sub> =25°C  | 76   |
|  |                                   | T <sub>C</sub> =100°C | 48   |
| Pulsed Drain Current                             | I <sub>DM</sub> <sup>①②</sup>     | 304                   | A    |
| Continuous Drain Current                         | I <sub>D</sub>                    | T <sub>A</sub> =25°C  | 7.4  |
|  |                                   | T <sub>A</sub> =75°C  | 5.6  |
| Avalanche Current                                | I <sub>AS</sub> <sup>③</sup>      | 26                    | A    |
| Single Pulsed Avalanche Energy                   | E <sub>AS</sub> <sup>③</sup>      | 169                   | mJ   |
| Power Dissipation                                | P <sub>D</sub> <sup>①</sup>       | 208                   | W    |
| Operating Junction and Storage Temperature Range | T <sub>J</sub> , T <sub>stg</sub> | -55~+150              | °C   |

**Thermal Characteristics**

| Parameter                                   | Symbol                        | Value |      | Unit |
|---|-------------------------------|-------|------|------|
|   |                               | Typ   | Max  |      |
| Thermal Resistance from Junction to Case    | R <sub>θJC</sub>              | 0.4   | 0.6  | °C/W |
| Thermal Resistance from Junction to Ambient | R <sub>θJA</sub> <sup>⑥</sup> | 45    | 67.5 | °C/W |

# Typical Characteristics

## ELECTRICAL CHARACTERISTICS (T<sub>J</sub>=25°C unless otherwise specified)

### Static Characteristics

| Parameter                               | Symbol                           | Test Condition   | Value                 |     |      | Unit |    |
|---|----------------------------------|--|-----------------------|-----|------|------|----|
|   |                                  |  | Min                   | Typ | Max  |      |    |
| Drain-source breakdown voltage          | V <sub>(BR)DSS</sub>             | V <sub>GS</sub> =0V, I <sub>D</sub> =250μA               | 150                   | -   | -    | V    |    |
| Zero gate voltage drain current         | I <sub>DSS</sub>                 | V <sub>DS</sub> =150V, V <sub>GS</sub> =0V               | T <sub>J</sub> =25°C  | -   | -    | 1.0  | μA |
|   |                                  |  | T <sub>J</sub> =125°C | -   | -    | 100  |    |
| Gate-body leakage current               | I <sub>GSS</sub>                 | V <sub>GS</sub> =±20V, V <sub>DS</sub> =0V               | -                     | -   | ±100 | nA   |    |
| Gate-threshold voltage                  | V <sub>GS(th)</sub>              | V <sub>DS</sub> =V <sub>GS</sub> , I <sub>D</sub> =250μA | 2.0                   | 3.0 | 4.0  | V    |    |
| Static drain-source on-state resistance | R <sub>Ds(on)</sub> <sup>④</sup> | V <sub>GS</sub> =10V, I <sub>D</sub> =20A                | T <sub>J</sub> =25°C  | -   | 13   | 16   | mΩ |
|   |                                  |  | T <sub>J</sub> =125°C | -   | 25   | 31   |    |
| Forward transconductance                | g <sub>FS</sub>                  | V <sub>DS</sub> =5V, I <sub>D</sub> =20A                 | -                     | 66  | -    | S    |    |

### Dynamic Characteristics<sup>⑤</sup>

|                              |                     |   |   |      |   |    |
|------------------------------|---------------------|---|---|------|---|----|
| Input capacitance            | C <sub>iss</sub>    | V <sub>GS</sub> =0V, V <sub>DS</sub> =75V,<br>f=1MHz                                    | - | 2529 | - | pF |
| Output capacitance           | C <sub>oss</sub>    |   | - | 200  | - |    |
| Reverse transfer capacitance | C <sub>rss</sub>    |   | - | 7    | - |    |
| Gate resistance              | R <sub>g</sub>      | f=1MHz  | - | 0.6  | - | Ω  |
| Total gate charge            | Q <sub>g</sub>      | V <sub>GS</sub> =10V, V <sub>DS</sub> =75V, I <sub>D</sub> =20A                         | - | 31.4 | - | nC |
| Gate charge at threshold     | Q <sub>G(th)</sub>  |   | - | 7.1  | - |    |
| Gate-source charge           | Q <sub>gs</sub>     |   | - | 10.1 | - |    |
| Gate-drain charge            | Q <sub>gd</sub>     |   | - | 4.4  | - |    |
| Turn-on delay time           | t <sub>d(on)</sub>  | V <sub>DD</sub> =75V, V <sub>GS</sub> =10V,<br>I <sub>D</sub> =20A, R <sub>g</sub> =10Ω | - | 19   | - | ns |
| Turn-on rise time            | t <sub>r</sub>      |   | - | 19   | - |    |
| Turn-off delay time          | t <sub>d(off)</sub> |   | - | 36   | - |    |
| Turn-off fall time           | t <sub>f</sub>      |   | - | 23   | - |    |

### Reverse Diode Characteristics

|   |                               |  |   |     |     |    |
|---|-------------------------------|--|---|-----|-----|----|
| Drain-source diode forward voltage            | V <sub>SD</sub> <sup>④</sup>  | V <sub>GS</sub> =0V, I <sub>S</sub> =20A   | - | -   | 1.2 | V  |
| Continuous drain-source diode forward current | I <sub>S</sub> <sup>①</sup>   |  | - | -   | 76  | A  |
| Pulsed drain-source diode forward current     | I <sub>SM</sub> <sup>①②</sup> |  | - | -   | 304 | A  |
| Reverse recovery time                         | t <sub>rr</sub>               | V <sub>DD</sub> =75V, I <sub>S</sub> =20A, | - | 58  | -   | ns |
| Reverse recovery charge                       | Q <sub>rr</sub>               | di/dt=100A/μs                              | - | 170 | -   | nC |

Notes:

- ①.T<sub>C</sub>=25°C Limited only by maximum temperature allowed.
- ②.P<sub>w</sub>≤10μs, Duty cycle ≤1%.
- ③.EAS condition: V<sub>DD</sub>=75V, V<sub>GS</sub>=10V, L=0.5mH, R<sub>g</sub>=25Ω Starting T<sub>J</sub>=25°C.
- ④.Pulse Test : Pulse Width ≤380μs, duty cycle ≤2%.
- ⑤.Guaranteed by design, not subject to production.
- ⑥.Device mounted in a still air environment with T<sub>A</sub>=25°C.

# Typical Characteristics

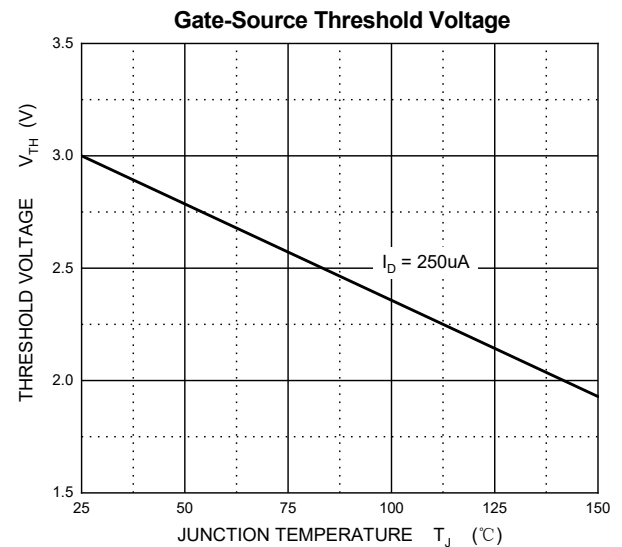
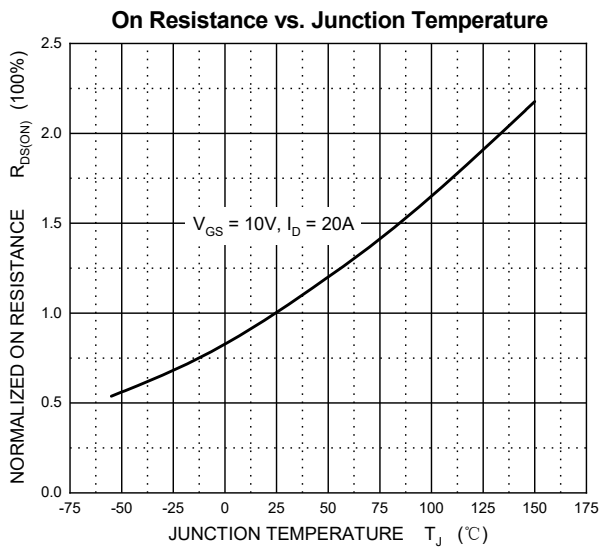
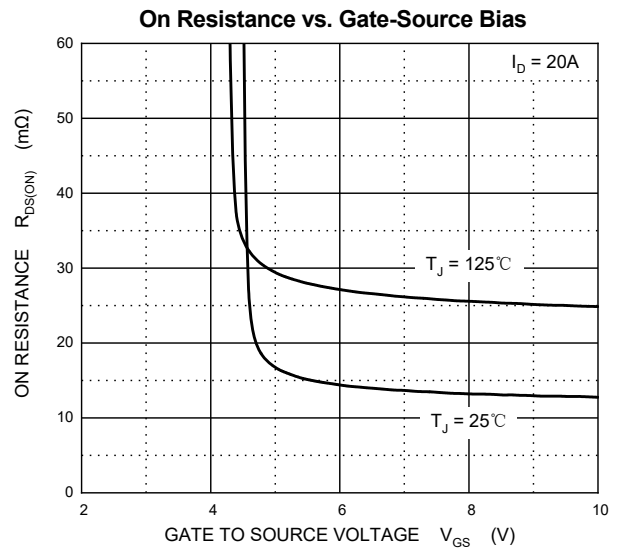
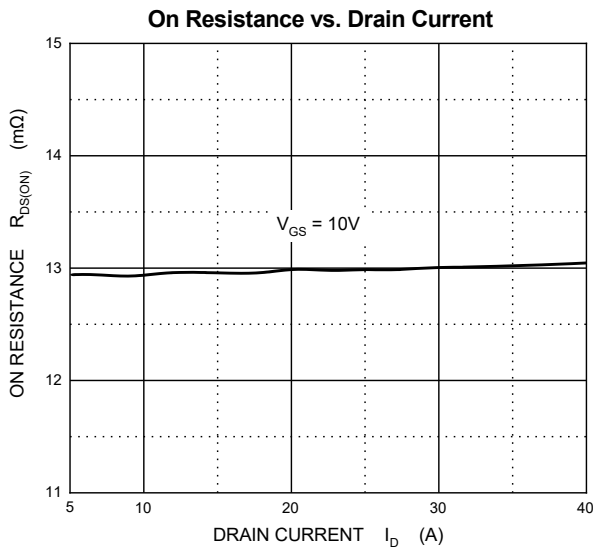
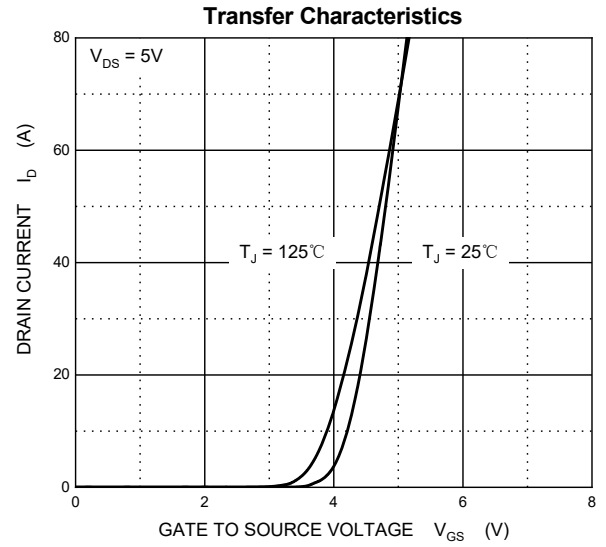
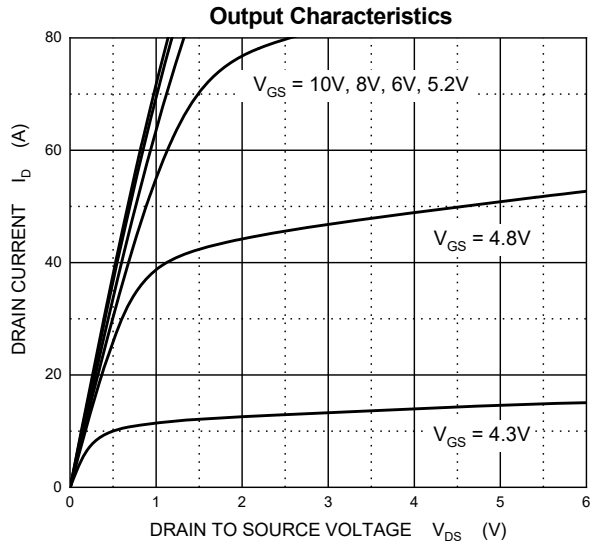

# Typical Characteristics

**Typical Capacitances**

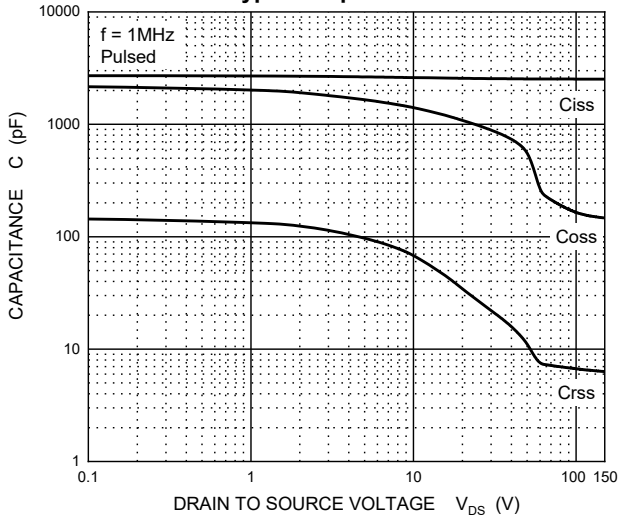

**Gate Charge**

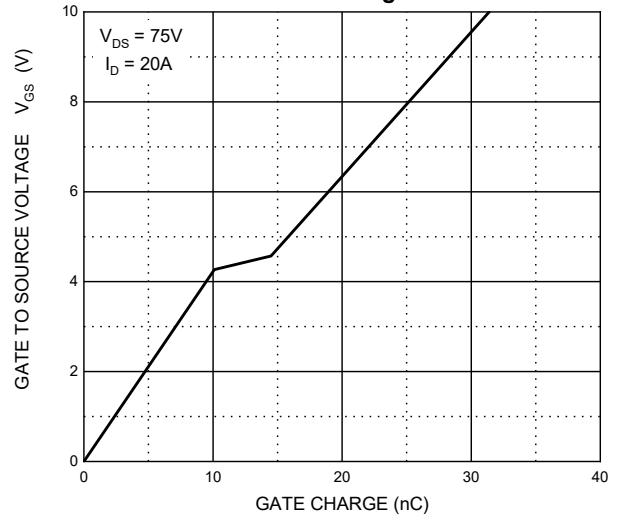

**Source-Drain Diode Forward Characteristics**

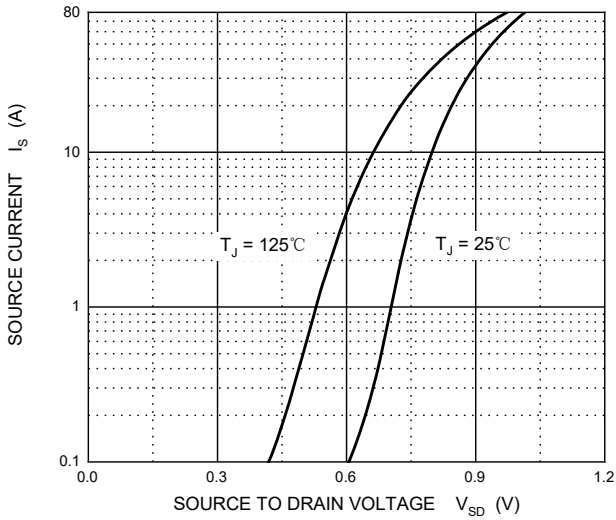

**Drain-Source Breakdown Voltage**

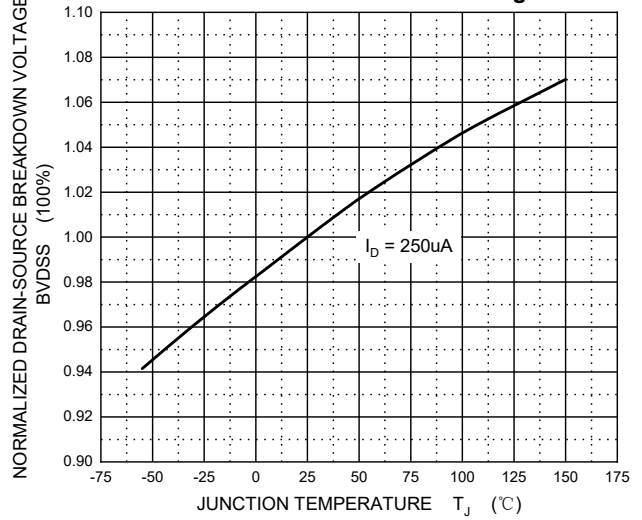

**Maximum Safe Operating Area**

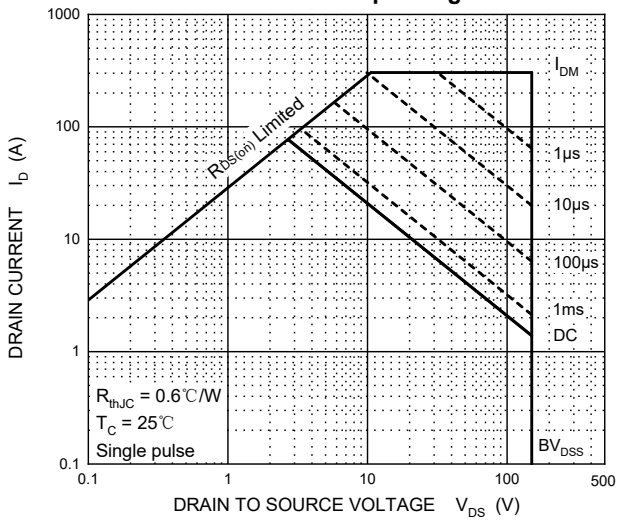

**Transient Thermal Impedance, Junction-Case**

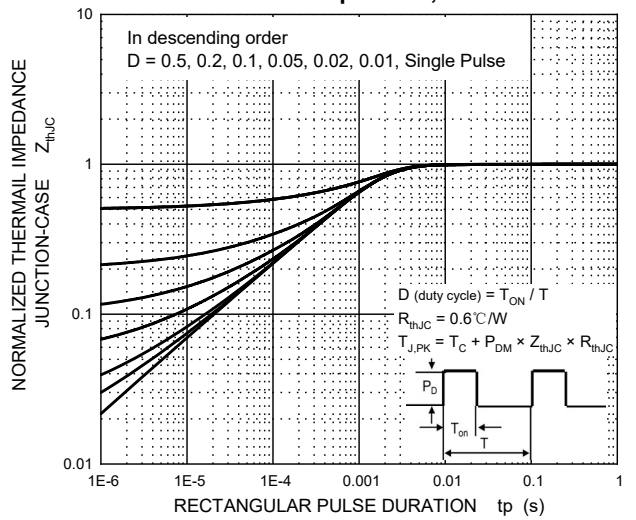

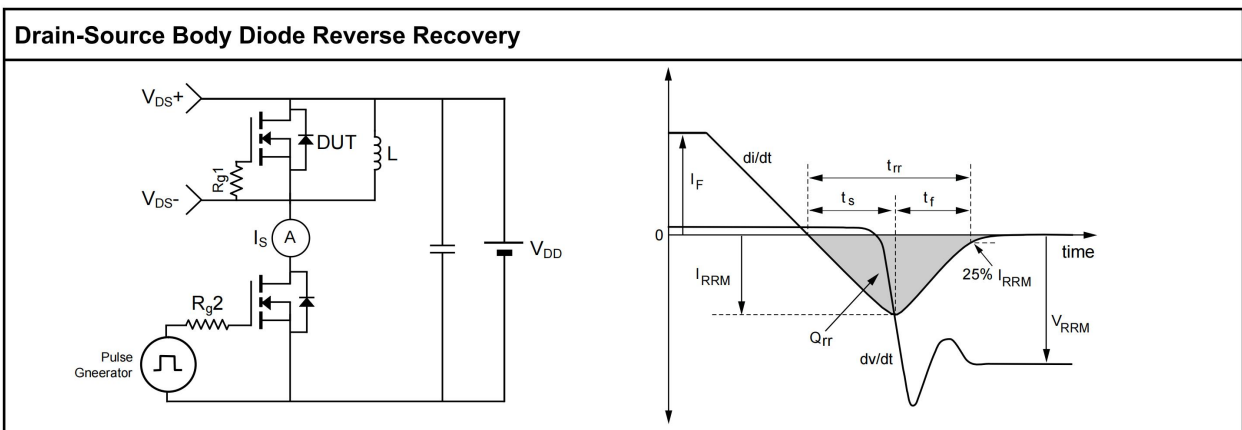
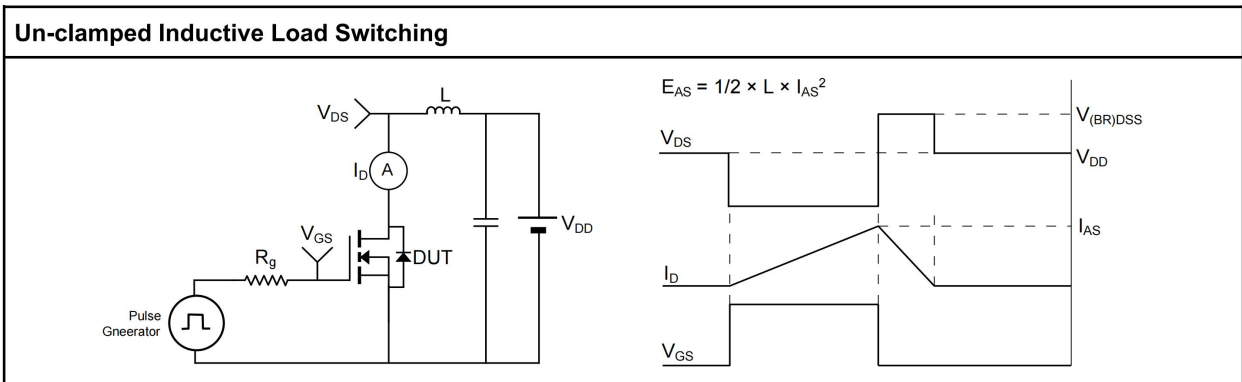
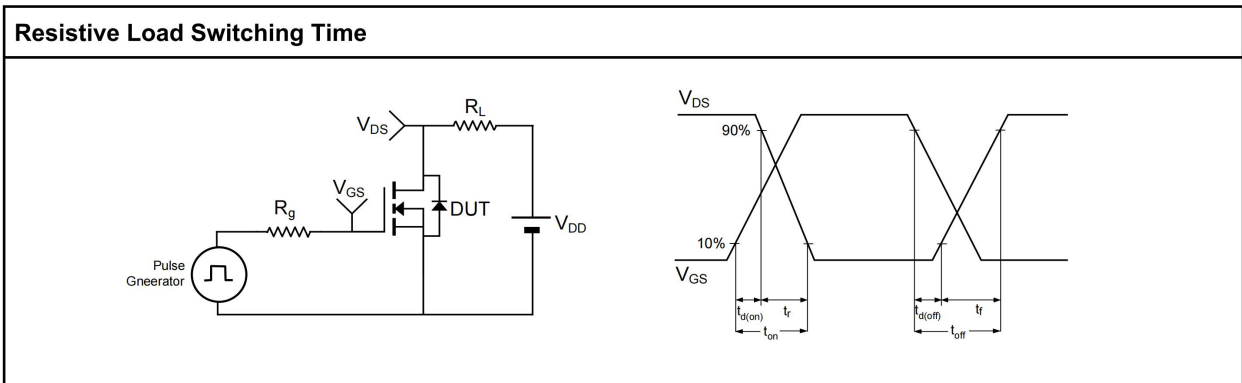
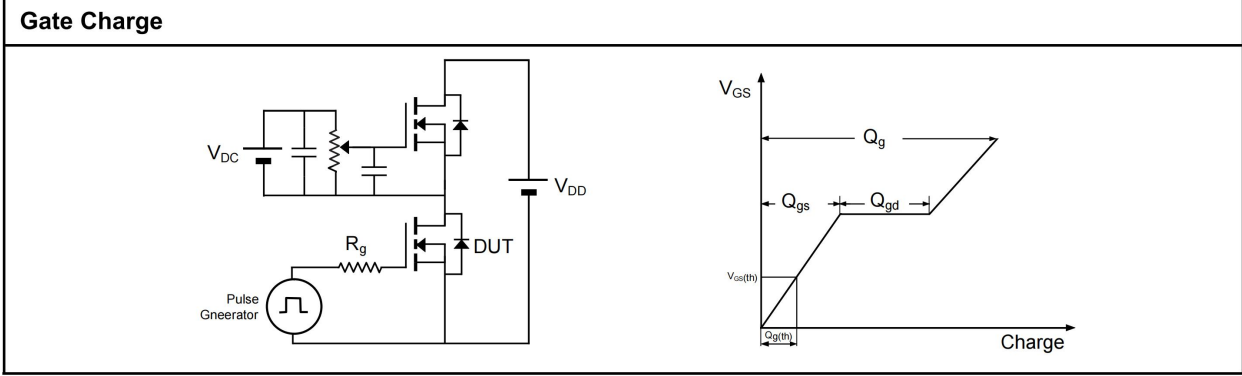

## TO-220-3L-CB Package Outline Dimensions

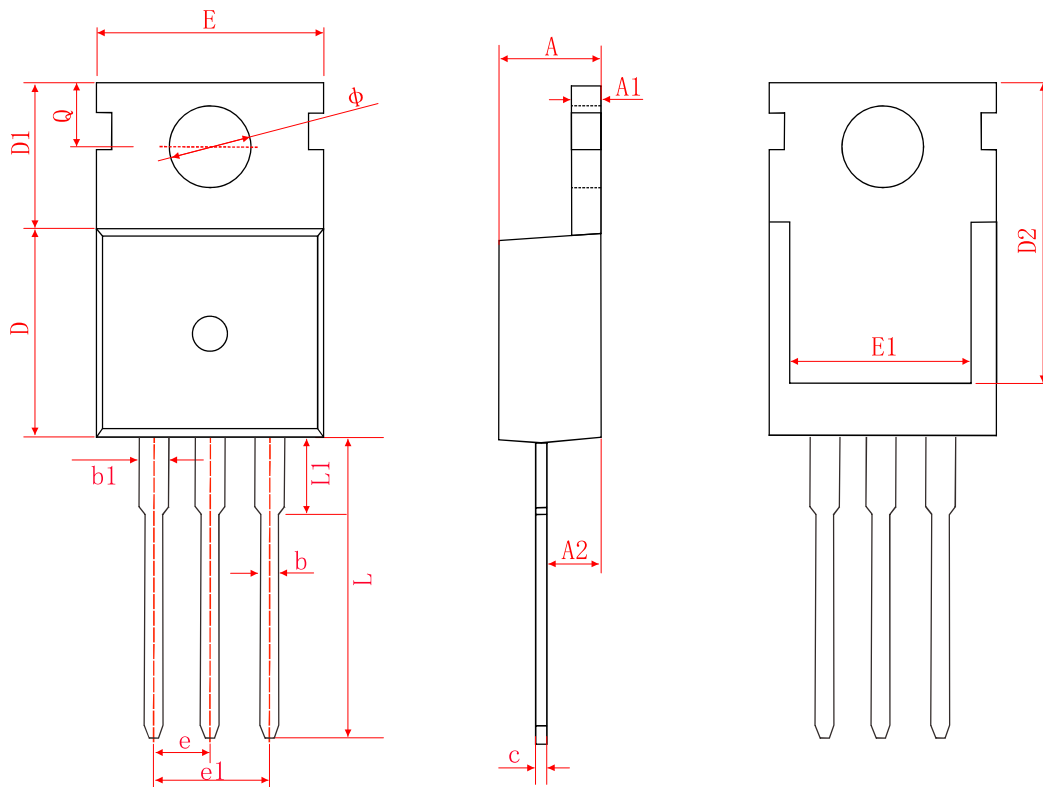

| Symbol | Dimensions In Millimeters |       | Dimensions In Inches |       |
|--------|---------------------------|-------|----------------------|-------|
|        | Min                       | Max   | Min                  | Max   |
| A      | 4.40                      | 4.60  | 0.173                | 0.181 |
| A1     | 1.25                      | 1.35  | 0.049                | 0.053 |
| A2     | 2.30                      | 2.50  | 0.091                | 0.098 |
| b      | 0.75                      | 0.85  | 0.030                | 0.033 |
| b1     | 1.25                      | 1.42  | 0.049                | 0.056 |
| c      | 0.45                      | 0.55  | 0.018                | 0.022 |
| D      | 9.10                      | 9.30  | 0.358                | 0.366 |
| D1     | 6.40                      | 6.60  | 0.252                | 0.260 |
| D2     | 13.07                     | 13.47 | 0.515                | 0.530 |
| e      | 2.54 TYP                  |       | 0.100 TYP            |       |
| e1     | 5.08 TYP                  |       | 0.200 TYP            |       |
| E      | 9.80                      | 10.15 | 0.386                | 0.400 |
| E1     | 7.80                      | 8.20  | 0.307                | 0.323 |
| Q      | 2.70                      | 2.90  | 0.106                | 0.114 |
| L      | 13.00                     | 13.45 | 0.512                | 0.530 |
| L1     | -                         | 3.40  |                      | 0.134 |
| Φ      | 3.50                      | 3.70  | 0.138                | 0.146 |