



## TO-220-3L Plastic-Encapsulate MOSFETS

### CJP03N90M1 N-Channel Power MOSFET

$V_{(BR)DSS}$	$R_{DS(on)TYP}$	$I_D$
900V	4.4Ω@10V	3A

#### GENERAL DESCRIPTION

This advanced high voltage MOSFET is designed to stand high energy in the avalanche mode and switch efficiently. This new high energy device also offers a drain-to-source diode fast recovery time. Designed for high voltage, high speed switching applications such as power supplies, converters, power motor controls and bridge circuits.

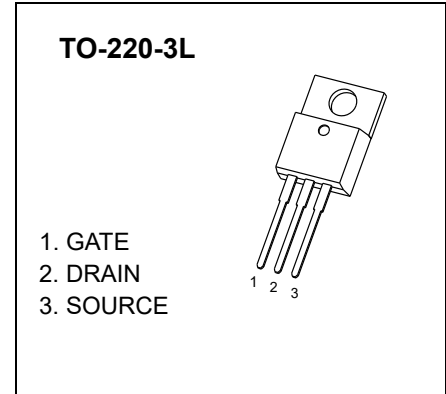

#### FEATURE

- High Current Rating
- Lower Capacitance
- Lower Total Gate Charge
- Tighter  $V_{SD}$  Specifications
- Avalanche Energy Specified
- Fast Switching Capability

#### MARKING



03N90M1 = Device code.  
Solid dot = Green molding compound device,  
if none, the normal device  
XXXX=Code

#### EQUIVALENT CIRCUIT

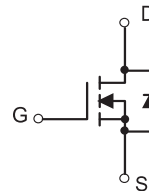

#### MAXIMUM RATINGS ( $T_J=25^\circ\text{C}$ unless otherwise noted)

Parameter	Symbol	Value	Unit
Drain-Source Voltage	$V_{DS}$	900	V
Gate-Source Voltage	$V_{GS}$	±30	V
Continuous Drain Current	$I_D^{①}$	3	A
Pulsed Drain Current	$I_{DM}^{①②}$	12	A
Single Pulsed Avalanche Energy	$E_{AS}^{③}$	150	mJ
Power Dissipation	$P_D^{①}$	96	W
Thermal Resistance from Junction to Ambient	$R_{\theta JA}^{⑥}$	62.5	$^\circ\text{C/W}$
Thermal Resistance from Junction to Case	$R_{\theta JC}^{①}$	1.3	$^\circ\text{C/W}$
Operating and Storage Temperature Range	$T_J, T_{STG}$	-55 ~ +150	$^\circ\text{C}$

# MOSFET ELECTRICAL CHARACTERISTICS

$T_J=25^{\circ}\text{C}$  unless otherwise specified

Parameter	Symbol	Test Condition	Min	Typ	Max	Unit	
<b>Off characteristics</b>							
Drain-source breakdown voltage	$V_{(BR)DSS}$	$V_{GS} = 0V, I_D = 1mA$	900	-	-	V	
Zero gate voltage drain current	$I_{DSS}$	$V_{DS}=900V, V_{GS}=0V$	$T_J=25^{\circ}\text{C}$	-	-	25	$\mu\text{A}$
			$T_J=125^{\circ}\text{C}$	-	-	100	
Gate-body leakage current	$I_{GSS}$	$V_{DS} = 0V, V_{GS} = \pm 30V$	-	-	$\pm 100$	nA	
<b>On characteristics</b> <sup>④</sup>							
Gate-threshold voltage	$V_{GS(th)}$	$V_{DS} = V_{GS}, I_D = 250\mu\text{A}$	2.0	3.5	4.0	V	
Static drain-source on-resistance	$R_{DS(on)}$	$V_{GS} = 10V, I_D = 1.5A$	-	4.8	5.5	$\Omega$	
<b>Dynamic characteristics</b> <sup>⑤</sup>							
Input capacitance	$C_{iss}$	$V_{DS} = 50V, V_{GS} = 0V, f = 1\text{MHz}$	-	526	-	pF	
Output capacitance	$C_{oss}$		-	32	-		
Reverse transfer capacitance	$C_{rss}$		-	2.4	-		
Gate resistance	$R_g$	$f = 1\text{MHz}$	-	4	-	$\Omega$	
<b>Switching characteristics</b> <sup>⑤</sup>							
Total gate charge	$Q_g$	$V_{DS} = 50V, V_{GS} = 10V, I_D = 3A$	-	12	-	nC	
Gate-source charge	$Q_{gs}$		-	3	-		
Gate-drain charge	$Q_{gd}$		-	4	-		
Turn-on delay time	$t_{d(on)}$	$V_{DD} = 450V, V_{GS} = 10V, R_G = 10\Omega, I_D = 3A$	-	7	-	ns	
Turn-on rise time	$t_r$		-	6	-		
Turn-off delay time	$t_{d(off)}$		-	17	-		
Turn-off fall time	$t_f$		-	11	-		
<b>Drain-Source Diode Characteristics</b>							
Drain-source diode forward voltage	$V_{SD}$ <sup>④</sup>	$V_{GS} = 0V, I_S = 3A$	-	-	1.2	V	
Maximum continuous drain-source diode forward current	$I_S$ <sup>①</sup>		-	-	3	A	
Maximum pulsed drain-source diode forward current	$I_{SM}$ <sup>①②</sup>		-	-	12	A	
Reverse recovery time	$t_{rr}$	$dI_F/dt = 100A/\mu\text{s}, I_S = 3A, V_{DD} = 50V$	-	328	-	ns	
Reverse recovery charge	$Q_{rr}$		-	1885	-	nC	

## Notes :

- $T_C=25^{\circ}\text{C}$  Limited only by maximum temperature allowed.
- $P_W \leq 10\mu\text{s}$ , Duty cycle  $\leq 1\%$ .
- EAS condition:  $V_{DD}=50V, V_{GS}=10V, L=10\text{mH}, R_g=25\Omega$  Starting  $T_J = 25^{\circ}\text{C}$ .
- Pulse Test : Pulse Width  $\leq 300\mu\text{s}$ , duty cycle  $\leq 2\%$ .
- Guaranteed by design, not subject to production.
- The value of  $R_{\theta JA}$  is measured with the device in a still air environment with  $T_a=25^{\circ}\text{C}$ .

# Typical Characteristics ( $T_J = 25^\circ\text{C}$ , unless otherwise specified)

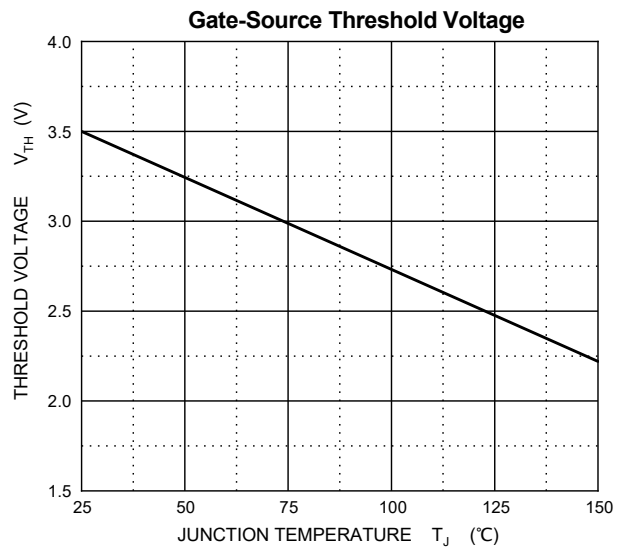
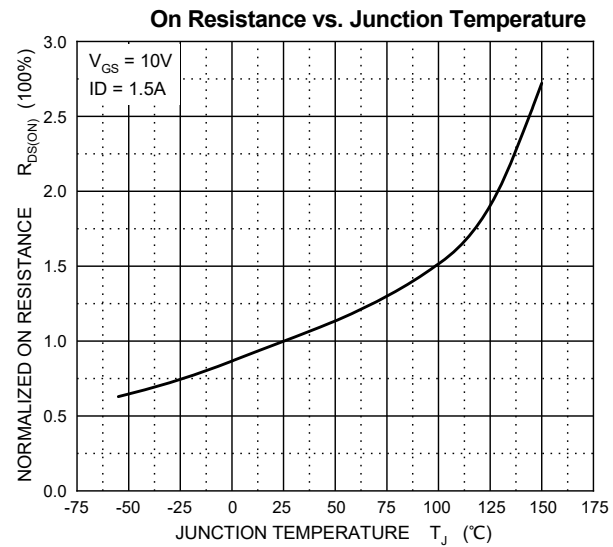
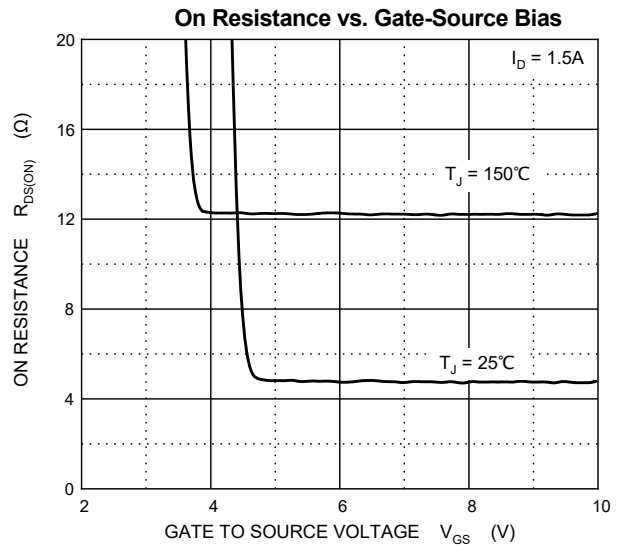
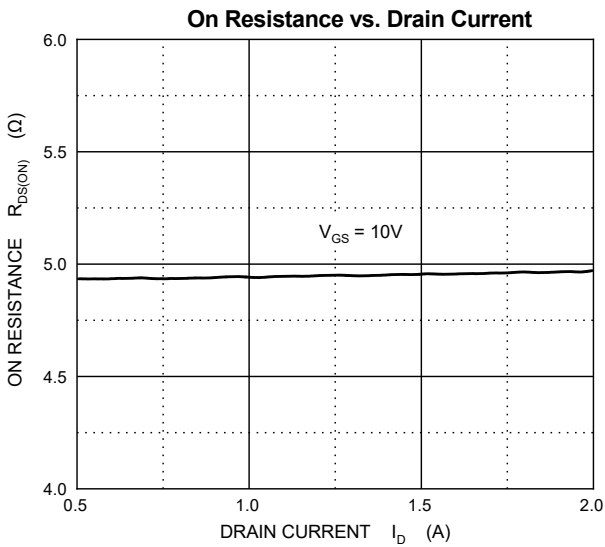
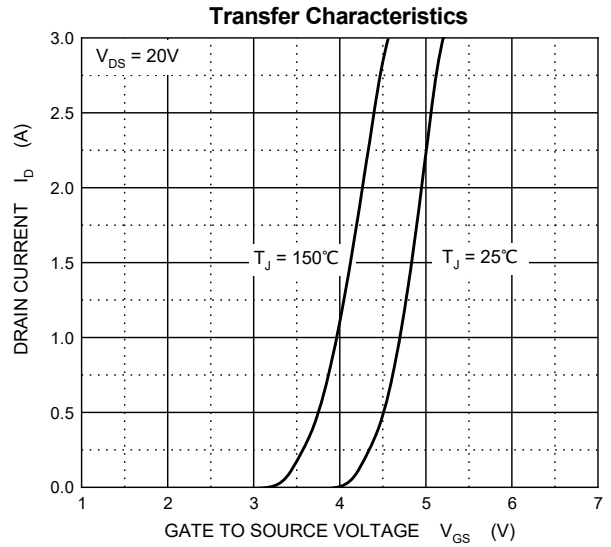
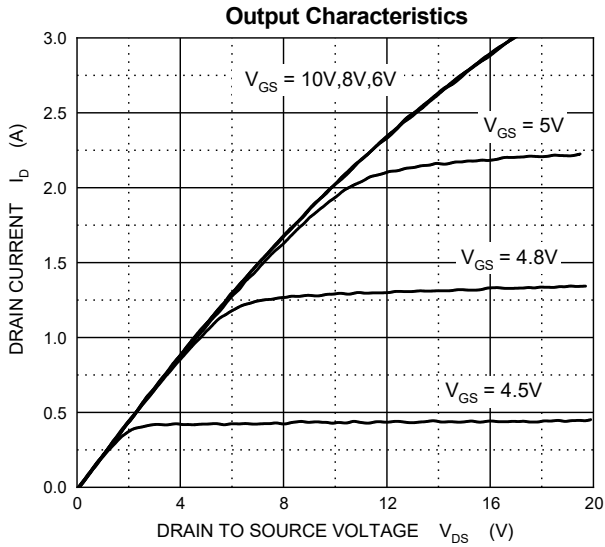

# Typical Characteristics (T<sub>J</sub> = 25°C, unless otherwise specified)

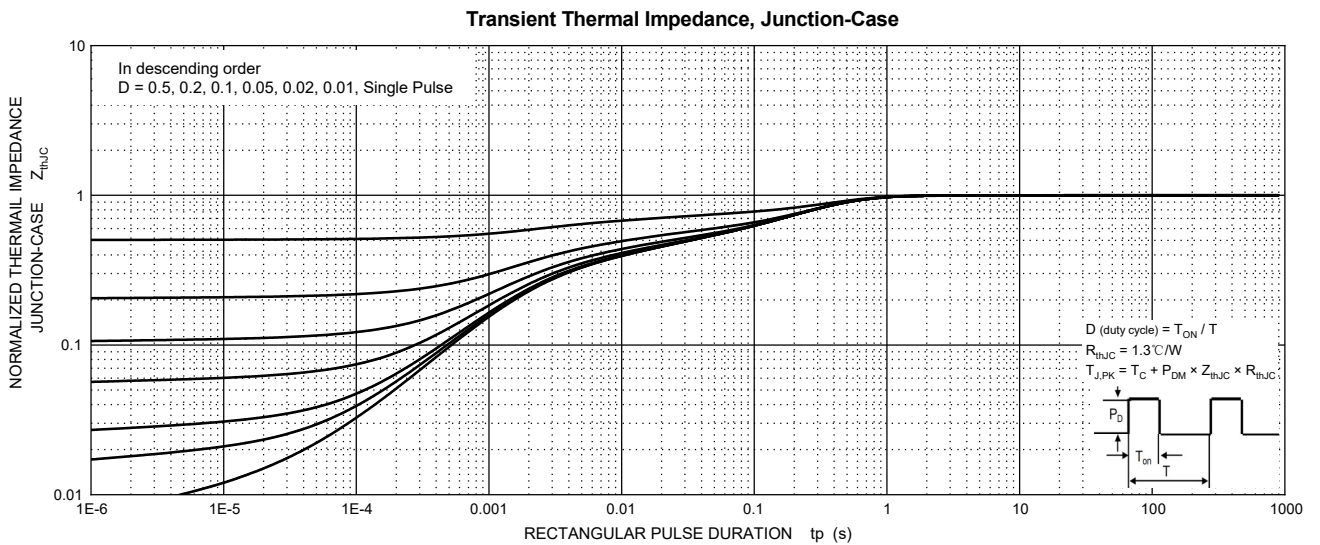
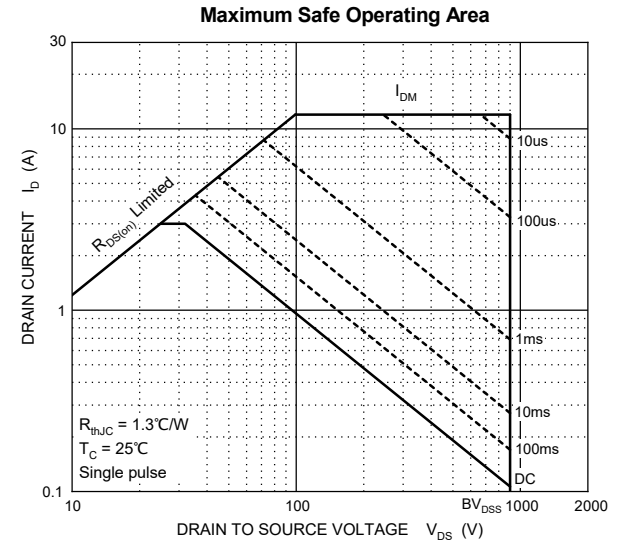
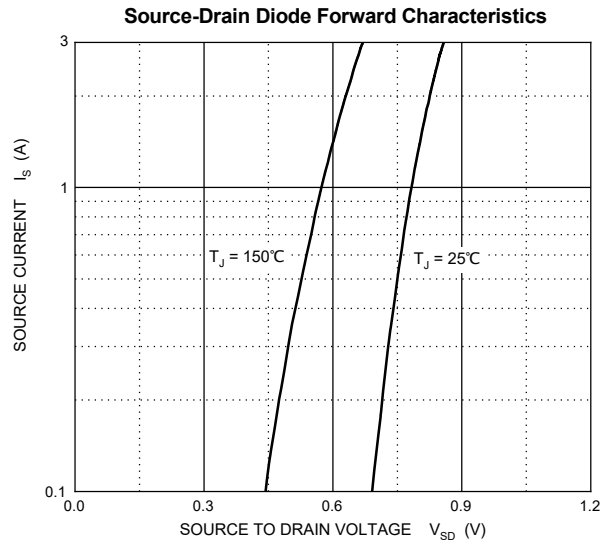
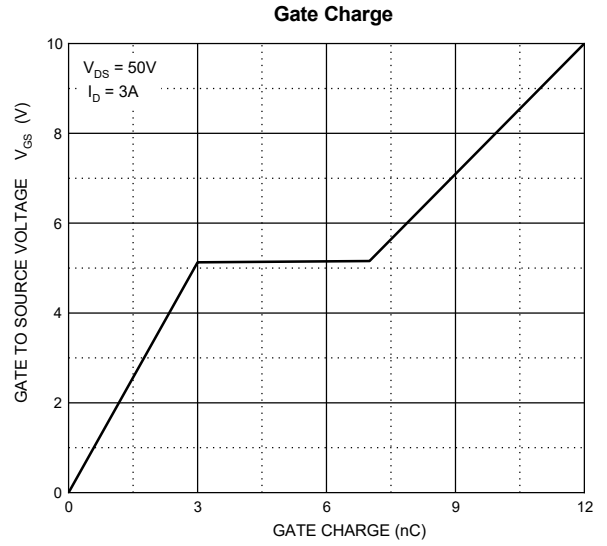
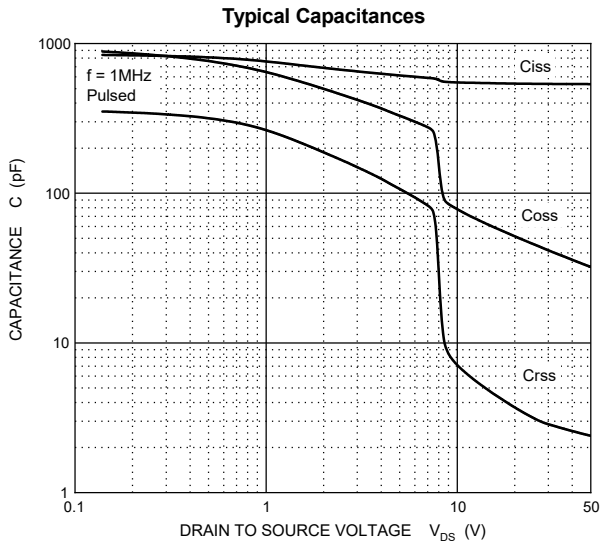

# TO-220-3L Package Outline Dimensions

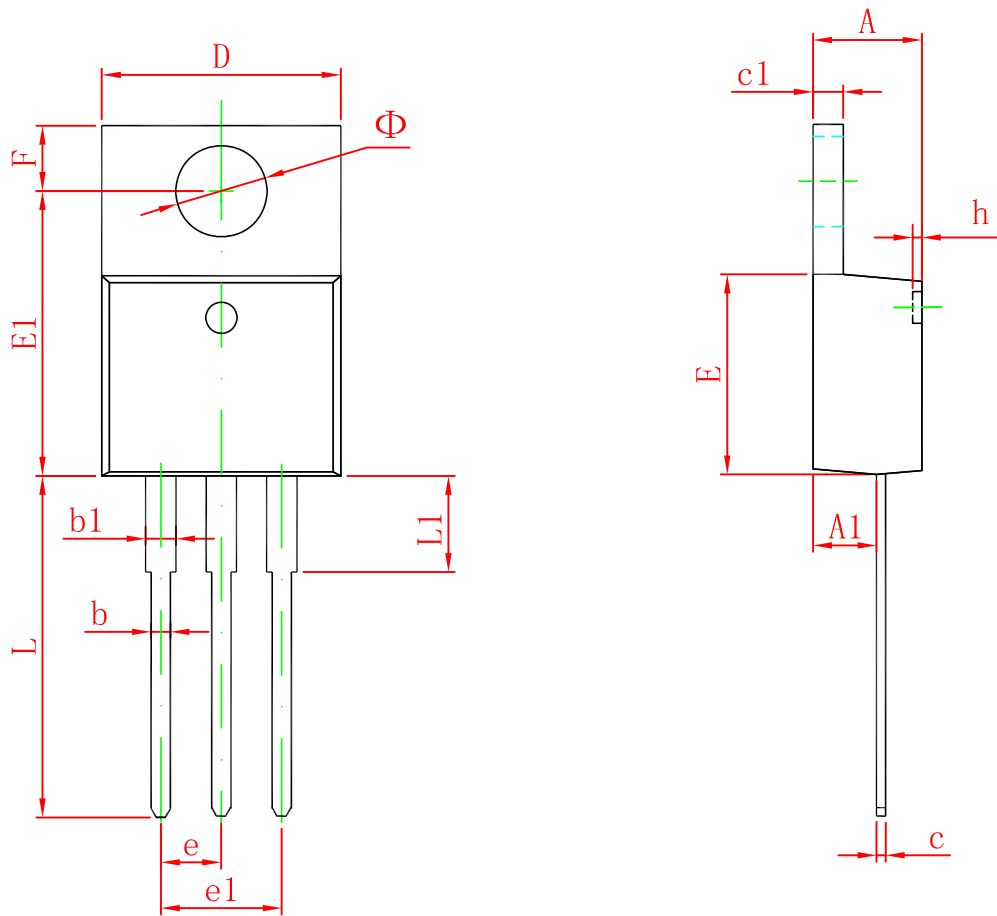

Symbol	Dimensions In Millimeters		Dimensions In Inches	
	Min	Max	Min	Max
A	4.470	4.670	0.176	0.184
A1	2.520	2.820	0.099	0.111
b	0.710	0.910	0.028	0.036
b1	1.170	1.370	0.046	0.054
c	0.310	0.530	0.012	0.021
c1	1.170	1.370	0.046	0.054
D	10.010	10.310	0.394	0.406
E	8.500	8.900	0.335	0.350
E1	12.060	12.460	0.475	0.491
e	2.540 TYP		0.100 TYP	
e1	4.980	5.180	0.196	0.204
F	2.590	2.890	0.102	0.114
h	0.000	0.300	0.000	0.012
L	13.400	13.800	0.528	0.543
L1	3.560	3.960	0.140	0.156
$\Phi$	3.735	3.935	0.147	0.155