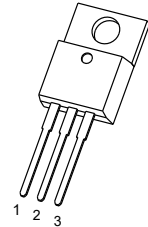

**TO-220-3L Plastic-Encapsulate MOSFETS****CJP07N50M1 N-Channel Power MOSFET**

$V_{(BR)DSS}$	$R_{DS(on)TYP}$	I_D
500V	0.6Ω@10V	7A

GENERAL DESCRIPTION

This advanced high voltage MOSFET is designed to stand high energy in the avalanche mode and switch efficiently. This new high energy device also offers a drain-to-source diode fast recovery time. Designed for high voltage, high speed switching applications such as power supplies, converters, power motor controls and bridge circuits.

TO-220-3L

1. GATE
2. DRAIN
3. SOURCE

FEATURE

- High Current Rating
- Lower Capacitance
- Lower Total Gate Charge
- Tighter V_{SD} Specifications
- Avalanche Energy Specified
- Fast Switching Capability

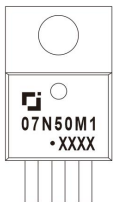
MARKING

07N50M1 = Device code.
Solid dot = Green molding compound device,
if none, the normal device
XXXX=Code

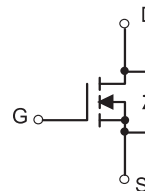
EQUIVALENT CIRCUIT**MAXIMUM RATINGS ($T_J=25^\circ\text{C}$ unless otherwise noted)**

Parameter	Symbol	Value	Unit
Drain-Source Voltage	V_{DS}	500	V
Gate-Source Voltage	V_{GS}	±30	V
Continuous Drain Current	I_D ①	7	A
Pulsed Drain Current	I_{DM} ①②	28	A
Single Pulsed Avalanche Energy	E_{AS} ③	400	mJ
Power Dissipation	P_D ①	139	W
Thermal Resistance from Junction to Ambient	$R_{\theta JA}$ ⑥	55	°C/W
Thermal Resistance from Junction to Case	$R_{\theta JC}$ ①	0.9	°C/W
Operating and Storage Temperature Range	T_J, T_{STG}	-55 ~+150	°C

MOSFET ELECTRICAL CHARACTERISTICS

$T_J=25^{\circ}\text{C}$ unless otherwise specified

Parameter	Symbol	Test Condition	Min	Typ	Max	Unit	
Off characteristics							
Drain-source breakdown voltage	$V_{(BR)DSS}$	$V_{GS} = 0V, I_D = 250\mu A$	500	-	-	V	
Zero gate voltage drain current	I_{DSS}	$V_{DS}=500V, V_{GS}=0V$	$T_J=25^{\circ}\text{C}$	-	-	1.0	μA
			$T_J=125^{\circ}\text{C}$	-	-	100	
Gate-body leakage current	I_{GSS}	$V_{DS} = 0V, V_{GS} = \pm 30V$	-	-	± 100	nA	
On characteristics ^④							
Gate-threshold voltage	$V_{GS(th)}$	$V_{DS} = V_{GS}, I_D = 250\mu A$	2.0	3.1	4.0	V	
Static drain-source on-resistance	$R_{DS(on)}$	$V_{GS} = 10V, I_D = 3.5A$	-	0.6	0.8	Ω	
Dynamic characteristics ^⑤							
Input capacitance	C_{iss}	$V_{DS} = 50V, V_{GS} = 0V, f = 1\text{MHz}$	-	1067	-	pF	
Output capacitance	C_{oss}		-	75	-		
Reverse transfer capacitance	C_{rss}		-	9.0	-		
Gate resistance	R_g	$f = 1\text{MHz}$	-	2.5	-	Ω	
Switching characteristics ^⑤							
Total gate charge	Q_g	$V_{DS} = 400V, V_{GS} = 10V, I_D = 3A$	-	23	-	nC	
Gate-source charge	Q_{gs}		-	5	-		
Gate-drain charge	Q_{gd}		-	7	-		
Turn-on delay time	$t_{d(on)}$	$V_{DD} = 250V, V_{GS} = 10V, R_G = 10\Omega, I_D = 7A$	-	10	-	ns	
Turn-on rise time	t_r		-	11	-		
Turn-off delay time	$t_{d(off)}$		-	33	-		
Turn-off fall time	t_f		-	14	-		
Drain-Source Diode Characteristics							
Drain-source diode forward voltage	V_{SD} ^④	$V_{GS} = 0V, I_S = 7A$	-	-	1.2	V	
Maximum continuous drain-source diode forward current	I_S ^①		-	-	7	A	
Maximum pulsed drain-source diode forward current	I_{SM} ^{①②}		-	-	28	A	
Reverse recovery time	t_{rr}	$dI_F/dt = 100A/\mu s, I_S = 7A, V_{DD} = 50V$	-	228	-	ns	
Reverse recovery charge	Q_{rr}		-	1820	-	nC	

Notes :

- $T_C=25^{\circ}\text{C}$ Limited only by maximum temperature allowed.
- $P_{W} \leq 10\mu s$, Duty cycle $\leq 1\%$.
- EAS condition: $V_{DD}=50V, V_{GS}=10V, L=10mH, R_g=25\Omega$ Starting $T_J = 25^{\circ}\text{C}$.
- Pulse Test : Pulse Width $\leq 300\mu s$, duty cycle $\leq 2\%$.
- Guaranteed by design, not subject to production.
- The value of $R_{\theta JA}$ is measured with the device in a still air environment with $T_a=25^{\circ}\text{C}$.

Typical Characteristics ($T_J = 25^\circ\text{C}$, unless otherwise specified)

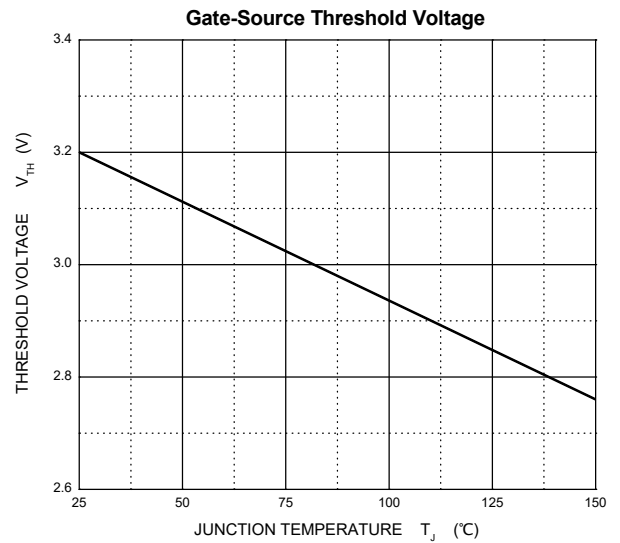
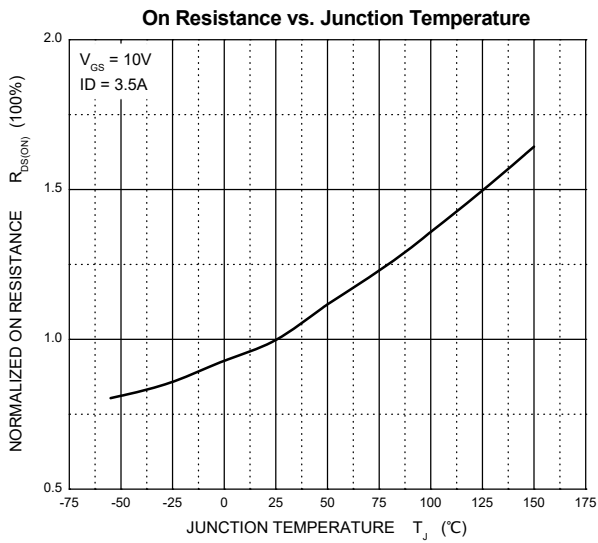
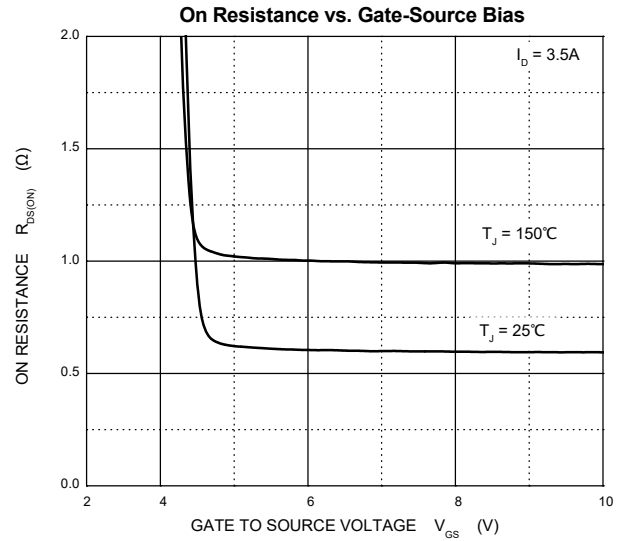
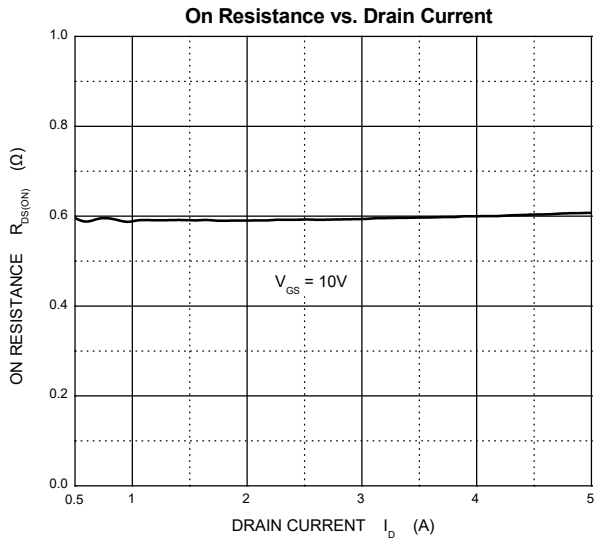
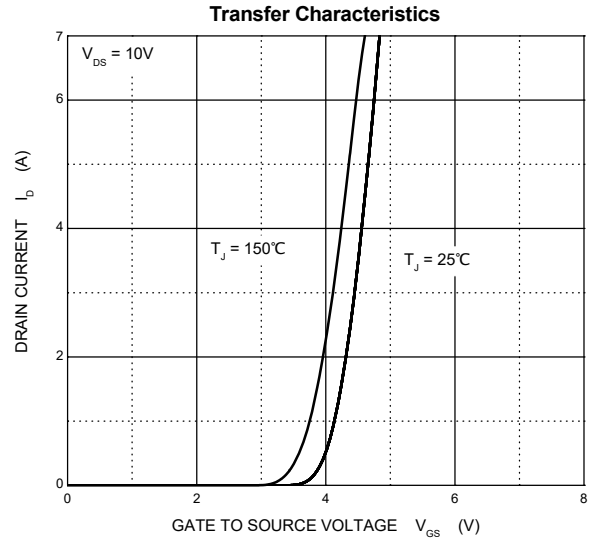
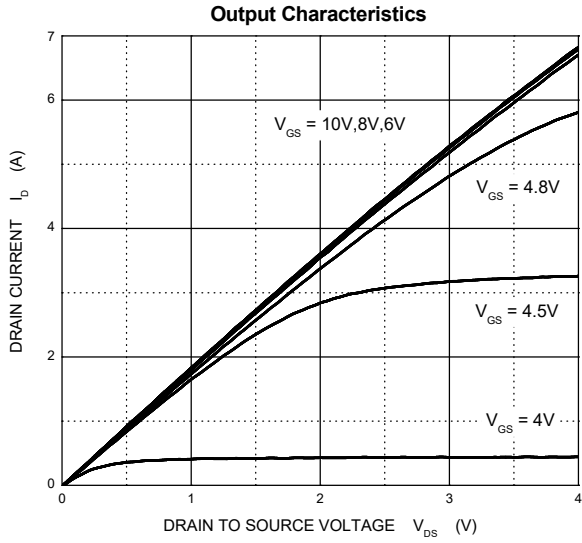

Typical Characteristics ($T_J = 25^\circ\text{C}$, unless otherwise specified)

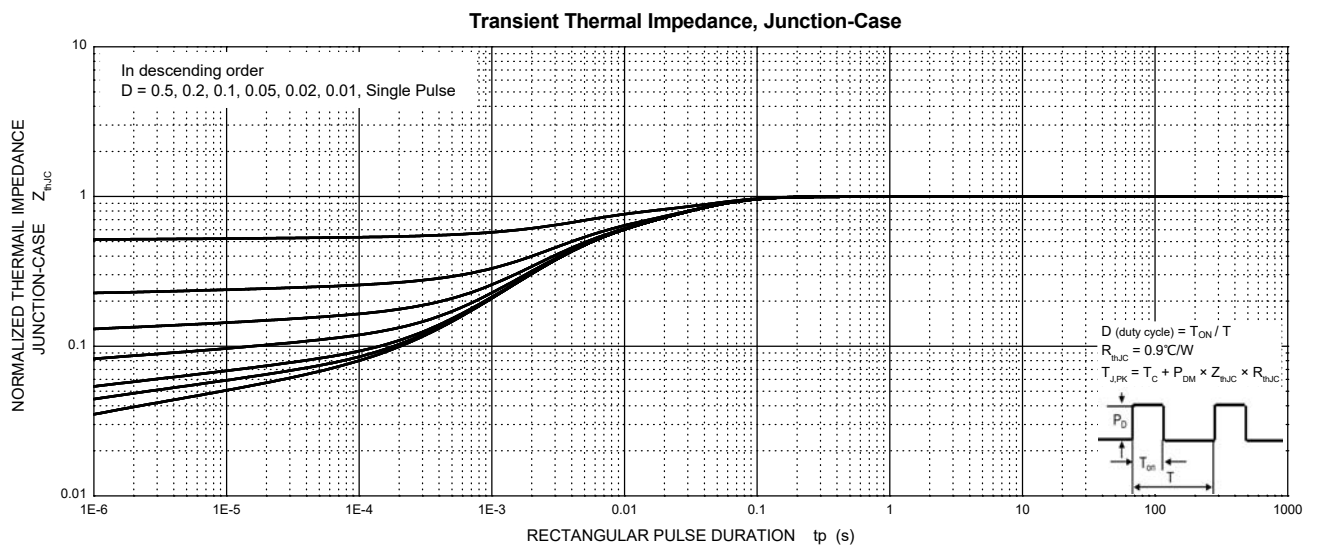
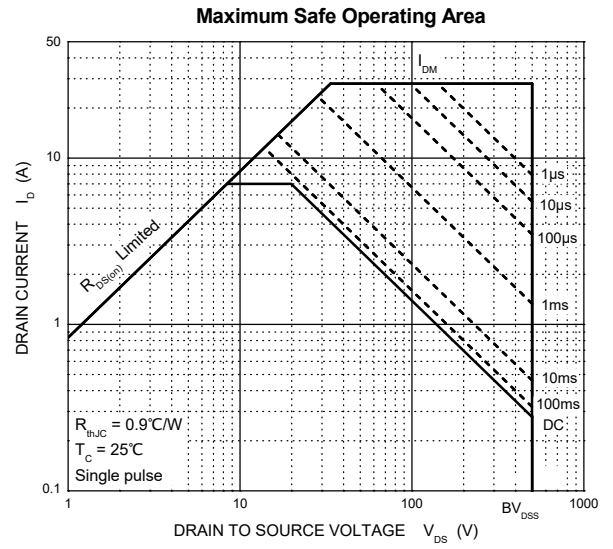
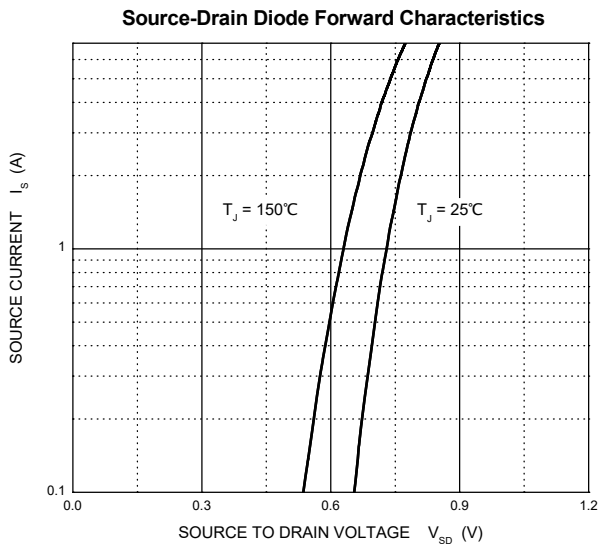
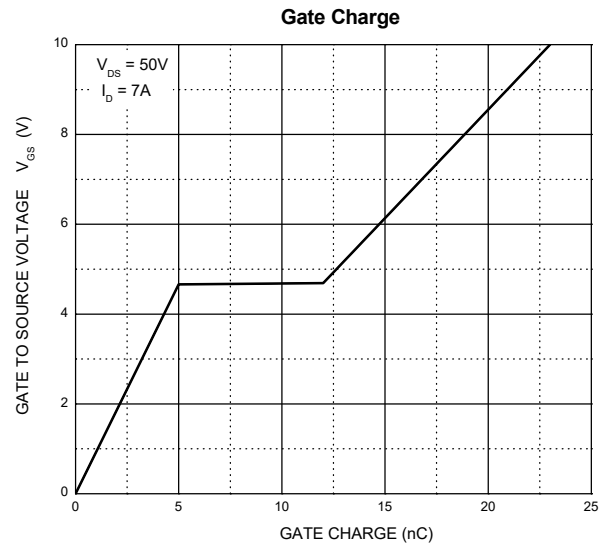
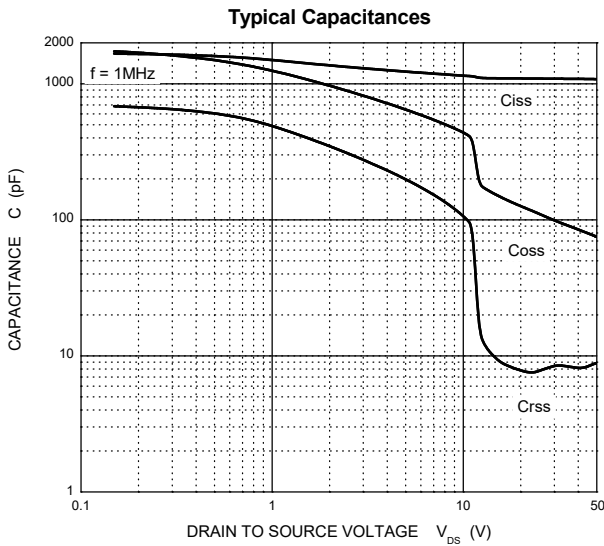

TO-220-3L Package Outline Dimensions

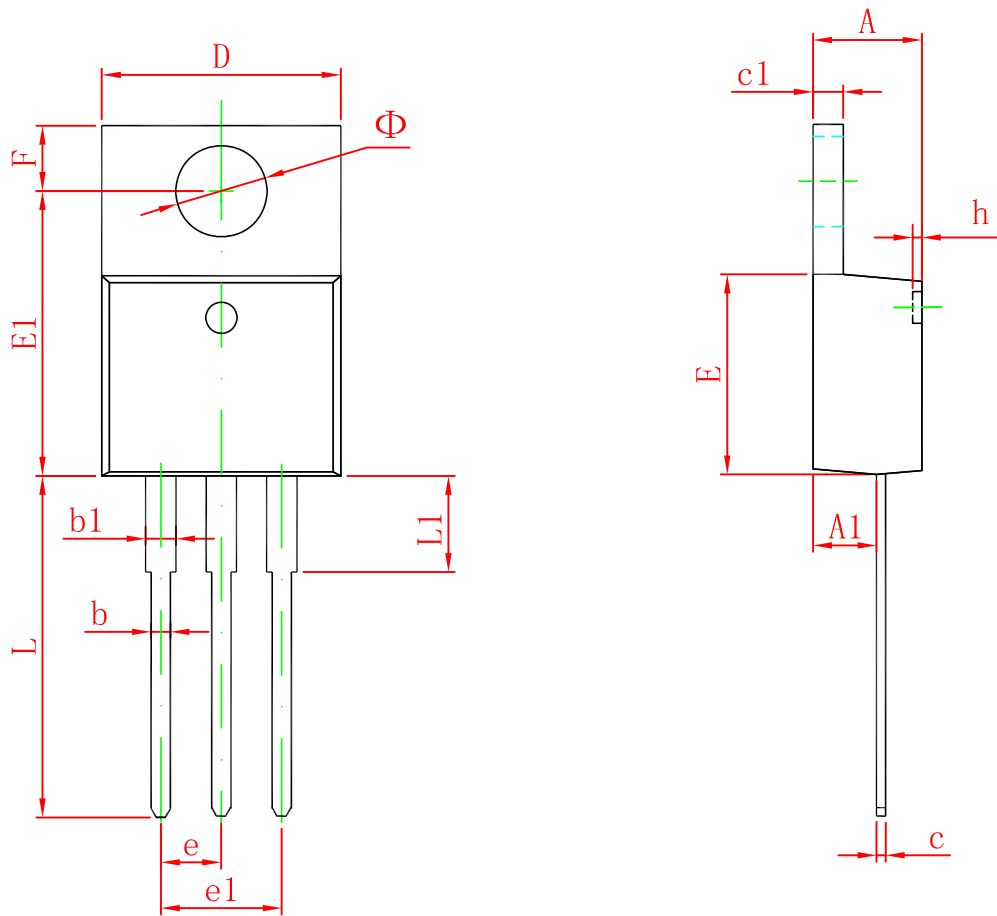

Symbol	Dimensions In Millimeters		Dimensions In Inches	
	Min	Max	Min	Max
A	4.470	4.670	0.176	0.184
A1	2.520	2.820	0.099	0.111
b	0.710	0.910	0.028	0.036
b1	1.170	1.370	0.046	0.054
c	0.310	0.530	0.012	0.021
c1	1.170	1.370	0.046	0.054
D	10.010	10.310	0.394	0.406
E	8.500	8.900	0.335	0.350
E1	12.060	12.460	0.475	0.491
e	2.540 TYP		0.100 TYP	
e1	4.980	5.180	0.196	0.204
F	2.590	2.890	0.102	0.114
h	0.000	0.300	0.000	0.012
L	13.400	13.800	0.528	0.543
L1	3.560	3.960	0.140	0.156
Φ	3.735	3.935	0.147	0.155