



CJTS010X

Logic

1 Introduction

The CJTS010X is a X-bit, dual supply translating transceiver with auto direction sensing, that enables bidirectional voltage level translation. It features two 1-bit input-output ports (A and B), one output enable input (OE) and two supply pins ($V_{CC(A)}$ and $V_{CC(B)}$). $V_{CC(A)}$ can be supplied at any voltage between 1.65V and 3.6V. $V_{CC(B)}$ can be supplied at any voltage between 2.3V and 5.5V. This flexibility makes the device suitable for translating between any of the voltage nodes (1.8V, 2.5V, 3.3V and 5.0V). Pins A and OE are referenced to $V_{CC(A)}$ and pin B is referenced to $V_{CC(B)}$. A LOW level at pin OE causes the outputs to assume a high-impedance OFF-state. This device is fully specified for partial power-down applications using I_{OFF} . The I_{OFF} circuitry disables the output, preventing the damaging backflow current through the device when it is powered down.

2 Available Packages

PART NUMBER	PACKAGE
CJTS0101	SOT-23-6L
	SOT-363
CJTS0102	TSSOP8(3x3)
	VSSOP8
	DFN1.35x1-8L
CJTS0103	QFN1.8x1.4-10L
CJTS0104	SOP14
	TSSOP14
	QFN3.5x3.5-14L
CJTS0108	TSSOP20

Note: For all available packages, please refer to the part Orderable Information.

3 Features

- Wide supply voltage range:
 - $V_{CC(A)}$: 1.65V to 3.6V
 - $V_{CC(B)}$: 2.3V to 5.5V
- Maximum data rates:
 - Push-pull: 50 Mbps
 - Open-drain: 2 Mbps
- I_{OFF} circuitry provides partial Power-down mode operation
- Inputs accept voltages up to 5.5V
- Specified from -40°C to +125°C

4 Applications

- Handsets
- Smartphones
- Tablets
- Desktop PCs

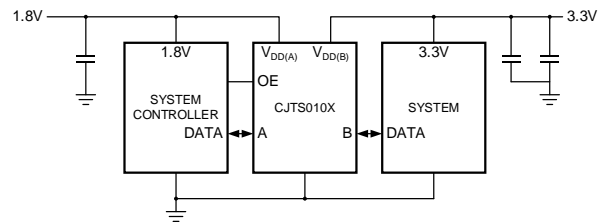

Typical operating circuit

5 Orderable Information

DEVICE	PACKAGE	OP TEMP	ECO PLAN	MSL	PACKING OPTION	SORT
CJTS0101M6N	SOT-23-6L	-40~125°C	RoHS & Green	Level 3 168HR	Tape and Reel 3000 Units/Reel	Active
CJTS0101R6N	SOT-363	-40~125°C	RoHS & Green	Level 3 168HR	Tape and Reel 3000 Units/Reel	Active
CJTS0102BAN	TSSOP8(3x3)	-40~125°C	RoHS & Green	Level 3 168HR	Tape and Reel 3000 Units/Reel	Active
CJTS0102VAN	VSSOP8	-40~125°C	RoHS & Green	Level 3 168HR	Tape and Reel 3000 Units/Reel	Active
CJTS0102DMN	DFN1.35x1-8L	-40~125°C	RoHS & Green	Level 3 168HR	Tape and Reel 5000 Units/Reel	Active
CJTS0103QPN	QFN1.8x1.4-10L	-40~125°C	RoHS & Green	Level 3 168HR	Tape and Reel 3000 Units/Reel	Active
CJTS0104ADN	SOP14	-40~125°C	RoHS & Green	Level 3 168HR	Tape and Reel 4000 Units/Reel	Active
CJTS0104BDN	TSSOP14	-40~125°C	RoHS & Green	Level 3 168HR	Tape and Reel 5000 Units/Reel	Active
CJTS0104QIN	QFN3.5x3.5-14L	-40~125°C	RoHS & Green	Level 3 168HR	Tape and Reel 5000 Units/Reel	Active
CJTS0108BGN	TSSOP20	-40~125°C	RoHS & Green	Level 3 168HR	Tape and Reel 4000 Units/Reel	Active

Note:

ECO PLAN: For the RoHS and Green certification standards of this product, please refer to the official report provided by JSCJ.

MSL: Moisture Sensitivity Level. Determined according to JEDEC industry standard classification.

SORT: Specifically defined as follows:

Active: Recommended for new products;

Customized: Products manufactured to meet the specific needs of customers;

Preview: The device has been released and has not been fully mass produced. The sample may or may not be available;

NoRD: It is not recommended to use the device for new design. The device is only produced for the needs of existing customers;

Obsolete: The device has been discontinued.

6 Pin Configuration and Marking Information

6.1 Pin Configuration

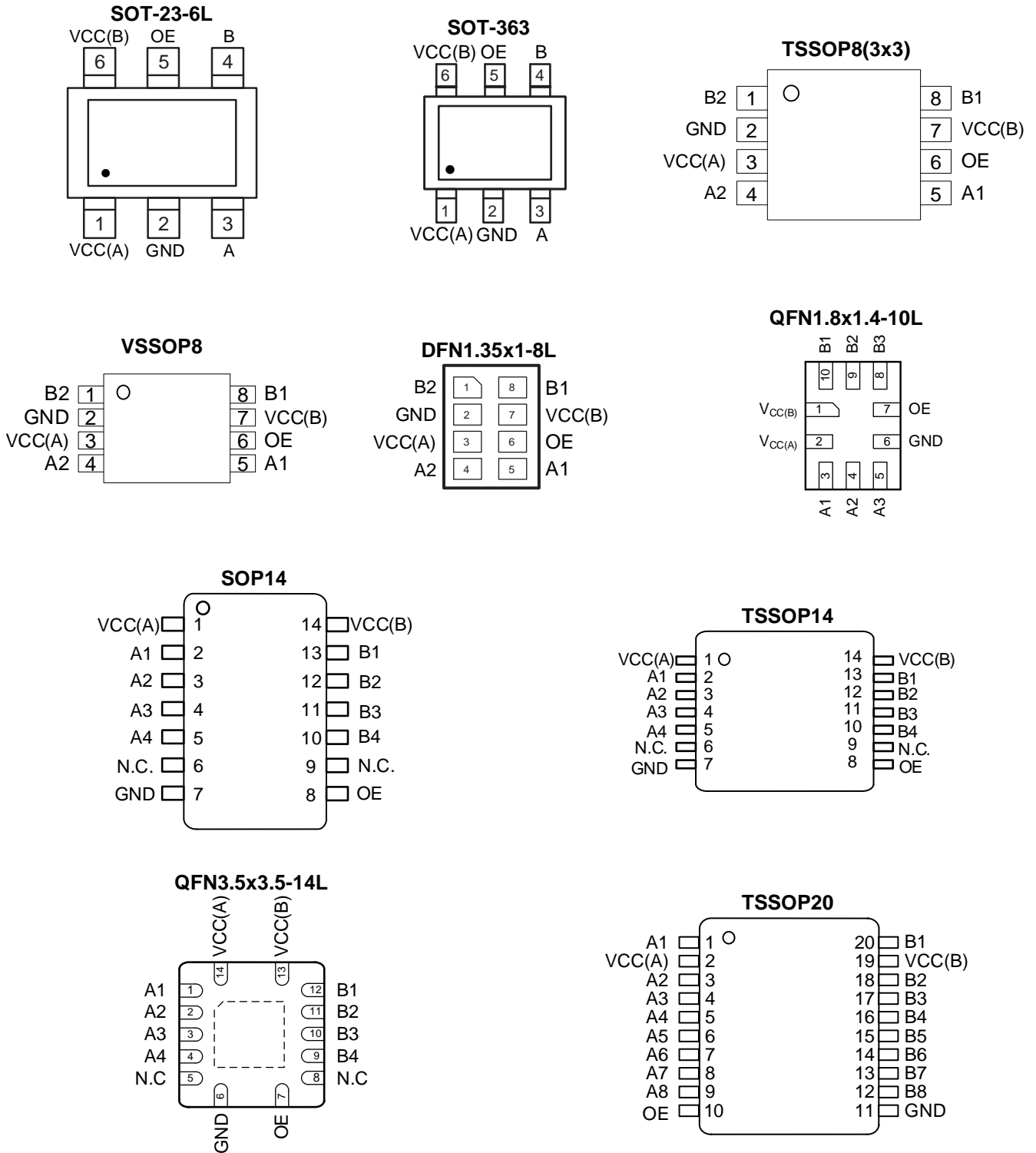

Figure 6-1 Pin configuration

6.2 Pin Function
6.2.1 SOT-23-6L/SOT-363

PIN		I/O ⁽¹⁾	DESCRIPTION
No.	NAME		
1	VCC(A)	P	Supply voltage A
2	GND	G	Ground (0V)
3	A	I/O	Data input or output (referenced to VCC(A))
4	B	I/O	Data input or output (referenced to VCC(B))
5	OE	I	Output enable input (active HIGH; referenced to VCC(A))
6	VCC(B)	P	Supply voltage B

(1) I-Input, O-Output, P-Power, G-Ground

6.2.2 TSSOP8(3x3)/VSSOP8/DFN1.35x1-8L

PIN		I/O ⁽¹⁾	DESCRIPTION
No.	NAME		
1	B2	I/O	Data input or output (referenced to VCC(B))
2	GND	G	Ground (0V)
3	VCC(A)	P	Supply voltage A
4	A2	I/O	Data input or output (referenced to VCC(A))
5	A1	I/O	Data input or output (referenced to VCC(A))
6	OE	I	Output enable input (active HIGH; referenced to VCC(A))
7	VCC(B)	P	Supply voltage B
8	B1	I/O	Data input or output (referenced to VCC(B))

(1) I-Input, O-Output, P-Power, G-Ground

6.2.3 QFN1.8x1.4-10L

PIN		I/O ⁽¹⁾	DESCRIPTION
No.	NAME		
1	VCC(B)	P	Supply voltage B
2	VCC(A)	P	Supply voltage A
3	A1	I/O	Data input or output (referenced to VCC(A))
4	A2	I/O	Data input or output (referenced to VCC(A))
5	A3	I/O	Data input or output (referenced to VCC(A))
6	GND	G	Ground (0V)
7	OE	I	Output enable input (active HIGH; referenced to VCC(A))
8	B3	I/O	Data input or output (referenced to VCC(B))
9	B2	I/O	Data input or output (referenced to VCC(B))
10	B1	I/O	Data input or output (referenced to VCC(B))

(1) I-Input, O-Output, P-Power, G-Ground

6.2.4 SOP14/TSSOP14

PIN		I/O ⁽¹⁾	DESCRIPTION
No.	NAME		
1	VCC(A)	P	Supply voltage A
2	A1	I/O	Data input or output (referenced to VCC(A))
3	A2	I/O	Data input or output (referenced to VCC(A))
4	A3	I/O	Data input or output (referenced to VCC(A))
5	A4	I/O	Data input or output (referenced to VCC(A))
6	N.C.	-	Not connected
7	GND	G	Ground (0V)
8	OE	I	Output enable input (active HIGH; referenced to VCC(A))
9	N.C.	-	Not connected
10	B4	I/O	Data input or output (referenced to VCC(B))
11	B3	I/O	Data input or output (referenced to VCC(B))
12	B2	I/O	Data input or output (referenced to VCC(B))
13	B1	I/O	Data input or output (referenced to VCC(B))
14	VCC(B)	P	Supply voltage B

(1) I-Input, O-Output, P-Power, G-Ground

6.2.5 QFN3.5x3.5-14L

PIN		I/O ⁽¹⁾	DESCRIPTION
No.	NAME		
1	A1	I/O	Data input or output (referenced to VCC(A))
2	A2	I/O	Data input or output (referenced to VCC(A))
3	A3	I/O	Data input or output (referenced to VCC(A))
4	A4	I/O	Data input or output (referenced to VCC(A))
5	N.C.	-	Not connected
6	GND	G	Ground (0V)
7	OE	I	Output enable input (active HIGH; referenced to VCC(A))
8	N.C.	-	Not connected
9	B4	I/O	Data input or output (referenced to VCC(B))
10	B3	I/O	Data input or output (referenced to VCC(B))
11	B2	I/O	Data input or output (referenced to VCC(B))
12	B1	I/O	Data input or output (referenced to VCC(B))
13	VCC(B)	P	Supply voltage B
14	VCC(A)	P	Supply voltage A

(1) I-Input, O-Output, P-Power, G-Ground

6.2.6 TSSOP20

PIN		I/O ⁽¹⁾	DESCRIPTION
No.	NAME		
1	A1	I/O	Data input or output (referenced to VCC(A))
2	VCC(A)	P	Supply voltage A
3	A2	I/O	Data input or output (referenced to VCC(A))
4	A3	I/O	Data input or output (referenced to VCC(A))
5	A4	I/O	Data input or output (referenced to VCC(A))
6	A5	I/O	Data input or output (referenced to VCC(A))
7	A6	I/O	Data input or output (referenced to VCC(A))
8	A7	I/O	Data input or output (referenced to VCC(A))
9	A8	I/O	Data input or output (referenced to VCC(A))
10	OE	I	Output enable input (active HIGH; referenced to VCC(A))
11	GND	G	Ground (0V)
12	B8	I/O	Data input or output (referenced to VCC(B))
13	B7	I/O	Data input or output (referenced to VCC(B))
14	B6	I/O	Data input or output (referenced to VCC(B))
15	B5	I/O	Data input or output (referenced to VCC(B))
16	B4	I/O	Data input or output (referenced to VCC(B))
17	B3	I/O	Data input or output (referenced to VCC(B))
18	B2	I/O	Data input or output (referenced to VCC(B))
19	VCC(B)	P	Supply voltage B
20	B1	I/O	Data input or output (referenced to VCC(B))

(1) I-Input, O-Output, P-Power, G-Ground

6.3 Marking Information

6.3.1 CJTS0101

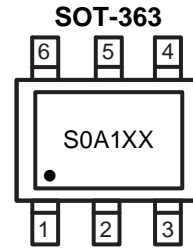
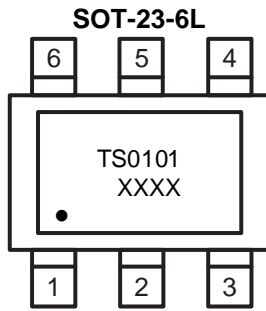

XXXX or XX: Code, indicates weekly record information.

6.3.2 CJTS0102

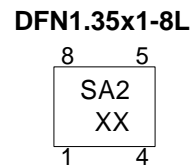
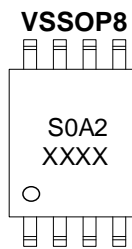
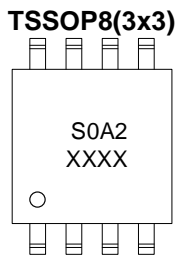

XXXX or XX: Code, indicates weekly record information.

6.3.3 CJTS0103

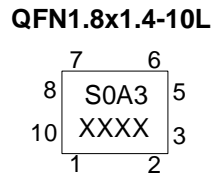

XXXX: Code, indicates weekly record information.

6.3.4 CJTS0104

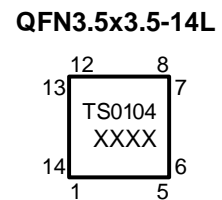
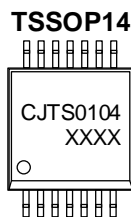
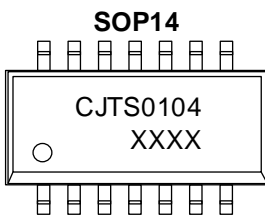

XXXX: Code, indicates weekly record information.

6.3.5 CJTS0108

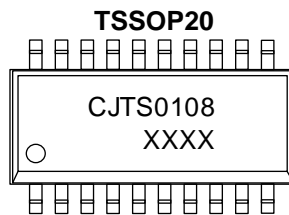

XXXX: Code, indicates weekly record information.

7 Specifications

7.1 Absolute Maximum Ratings

$T_{amb}=25^{\circ}\text{C}$, all voltage referenced to GND, unless otherwise specified.

SYMBOL	PARAMETER	CONDITIONS	MIN.	MAX.	UNIT
$V_{CC(A)}$	Supply voltage A	-	-0.5	+6.5	V
$V_{CC(B)}$	Supply voltage B	-	-0.5	+6.5	V
V_I	Input voltage	OE ⁽¹⁾	-0.5	+6.5	V
		A, B port; Power-down or 3-state mode ⁽¹⁾	-0.5	+6.5	V
		A, B port; Active mode ^{(1) (2) (3)}	-0.5	$V_{CCi}+0.5$	V
V_O	Output voltage	A, B port; Power-down or 3-state mode ⁽¹⁾	-0.5	+6.5	V
		A, B port; Active mode ^{(1) (3) (4)}	-0.5	$V_{CCo}+0.5$	V
I_{IK}	Input clamping current	$V_I < 0V$	-50	-	mA
I_{OK}	Output clamping current	$V_O < 0V$	-50	-	mA
I_O	Output current	$V_O = 0V$ to V_{CCo} ⁽⁴⁾	-	± 50	mA
I_{CC}	Supply current	$I_{CC(A)}$ or $I_{CC(B)}$	-	100	mA
I_{GND}	Ground current	-	-100	-	mA
T_{stg}	Storage temperature	-	-65	+150	$^{\circ}\text{C}$
P_{tot}	Total power dissipation	-	-	500	mW
T_L	Soldering temperature	10s	-	260	$^{\circ}\text{C}$

(1) The minimum input and minimum output voltage ratings may be exceeded if the input and output current ratings are observed.

(2) V_{CCo} is the supply voltage associated with the output.

(3) $V_{CCi}+0.5V$ or $V_{CCo}+0.5V$ should not exceed 6.5V.

(4) V_{CCo} is the supply voltage associated with the output.

7.2 Recommended Operating Conditions

SYMBOL	PARAMETER	CONDITIONS		MIN.	TYP.	MAX.	UNIT
$V_{CC(A)}$	Supply voltage A	-		1.65	-	3.6	V
$V_{CC(B)}$	Supply voltage B	-		2.3	-	5.5	V
V_I	Input voltage	OE		0	-	5.5	V
		Power-down or 3-state mode	A port	0	-	3.6	V
			B port	0	-	5.5	V
		Active mode	A, B port	0	-	V_{CCI}	V
V_O	Output voltage	Power-down or 3-state mode	A port	0	-	3.6	V
			B port	0	-	5.5	V
		Active mode	A, B port	0	-	V_{CCO}	V
T_{amb}	Ambient temperature	-		-40	-	+125	°C
$\Delta t/\Delta V$	Input transition rise and fall rate	A or B port; Push-pull driving	$V_{CC(A)}=1.65V$ to $3.6V$; $V_{CC(B)}=2.3V$ to $5.5V$	-	-	10	ns/V
		OE input	$V_{CC(A)}=1.65V$ to $3.6V$; $V_{CC(B)}=2.3V$ to $5.5V$	-	-	10	ns/V

- (1) The A and B sides of an unused I/O pair must be held in the same state, both at V_{CCI} or both at GND.
- (2) $V_{CC(A)}$ must be less than or equal to $V_{CC(B)}$.
- (3) V_{CCI} is the supply voltage associated with the input.
- (4) V_{CCO} is the supply voltage associated with the output.

7.3 Electrical Characteristics
7.3.1 DC Characteristics 1
 $T_{amb}=25^{\circ}\text{C}$, voltages are referenced to GND (ground=0V), unless otherwise specified.

SYMBOL	PARAMETER	CONDITIONS		MIN.	TYP.	MAX.	UNIT		
V_{OL}	LOW-level output voltage	A port; $V_I \leq 0.15\text{V}$; $V_{CC(B)}=1.65\text{V}$ to 5.5V ; $V_{CC(A)}=1.65\text{V}$; $I_O=-135\mu\text{A}$		-	0.25	-	V		
I_I	Input leakage current	OE input; $V_I=0\text{V}$ to 3.6V ; $V_{CC(A)}=1.65\text{V}$ to 3.6V ; $V_{CC(B)}=2.3\text{V}$ to 5.5V		-	-	± 1	μA		
I_{OZ}	OFF-state output current	A or B port; $V_O=0\text{V}$ or V_{CCO} ; $V_{CC(A)}=1.65\text{V}$ to 3.6V ; $V_{CC(B)}=2.3\text{V}$ to 5.5V		-	-	± 1	μA		
I_{OFF}	Power-off leakage current	A port; V_I or $V_O=0\text{V}$ to 3.6V ; $V_{CC(A)}=0\text{V}$; $V_{CC(B)}=0\text{V}$ to 5.5V		-	-	± 1	μA		
		B port; V_I or $V_O=0\text{V}$ to 5.5V ; $V_{CC(B)}=0\text{V}$; $V_{CC(A)}=0\text{V}$ to 3.6V		-	-	± 1	μA		
C_I	Input capacitance	OE input; $V_{CC(A)}=3.3\text{V}$; $V_{CC(B)}=3.3\text{V}$		-	2.6	-	pF		
$C_{I/O}$	Input/output capacitance	A port; $V_{CC(A)}=3.3\text{V}$; $V_{CC(B)}=3.3\text{V}$	Enabled	-	9	-	pF		
			Disabled	-	5.2	-	pF		
		B port; $V_{CC(A)}=3.3\text{V}$; $V_{CC(B)}=3.3\text{V}$	Enabled	-	10.5	-	pF		
			Disabled	-	9	-	pF		
$I_{CC(A)}$	Supply current	$V_{CC(A)}=1.8\text{V}$	$V_{CC(B)}=2.5\text{V}$	-	0.1	-	μA		
			$V_{CC(B)}=3.3\text{V}$	-	0.1	-	μA		
			$V_{CC(B)}=5.0\text{V}$	-	0.1	-	μA		
		$V_{CC(A)}=2.5\text{V}$	$V_{CC(B)}=2.5\text{V}$	-	0.1	-	μA		
			$V_{CC(B)}=3.3\text{V}$	-	0.1	-	μA		
			$V_{CC(B)}=5.0\text{V}$	-	0.1	-	μA		
		$V_{CC(A)}=3.3\text{V}$	$V_{CC(B)}=2.5\text{V}$	-	-	-	μA		
			$V_{CC(B)}=3.3\text{V}$	-	0.1	-	μA		
			$V_{CC(B)}=5.0\text{V}$	-	0.1	-	μA		
		$I_{CC(B)}$	Supply current	$V_{CC(A)}=1.8\text{V}$	$V_{CC(B)}=2.5\text{V}$	-	0.5	-	μA
					$V_{CC(B)}=3.3\text{V}$	-	1.5	-	μA
					$V_{CC(B)}=5.0\text{V}$	-	4.6	-	μA
$V_{CC(A)}=2.5\text{V}$	$V_{CC(B)}=2.5\text{V}$			-	0.1	-	μA		
	$V_{CC(B)}=3.3\text{V}$			-	0.8	-	μA		
	$V_{CC(B)}=5.0\text{V}$			-	3.8	-	μA		
$V_{CC(A)}=3.3\text{V}$	$V_{CC(B)}=2.5\text{V}$			-	-	-	μA		
	$V_{CC(B)}=3.3\text{V}$			-	0.1	-	μA		
	$V_{CC(B)}=5.0\text{V}$			-	2.8	-	μA		

Note:

- (1) $V_{CC(A)}$ must be less than or equal to $V_{CC(B)}$.
- (2) V_{CCO} is the supply voltage associated with the output.

7.3.2 DC Characteristics 2

T_{amb}=-40°C to +85°C, voltages are referenced to GND (ground=0V), unless otherwise specified.

SYMBOL	PARAMETER	CONDITIONS		MIN.	TYP.	MAX.	UNIT
V _{IH}	HIGH-level input voltage	A port	V _{CC(A)} =1.65V to 1.95V; V _{CC(B)} =2.3V to 5.5V	V _{CC(A)} -0.2	-	-	V
			V _{CC(A)} =2.3V to 3.6V; V _{CC(B)} =2.3V to 5.5V	V _{CC(A)} -0.4	-	-	V
		B port	V _{CC(A)} =1.65V to 3.6V; V _{CC(B)} =2.3V to 5.5V	V _{CC(B)} -0.4	-	-	V
		OE input	V _{CC(A)} =1.65V to 3.6V; V _{CC(B)} =2.3V to 5.5V	0.65V _{CC(A)}	-	-	V
V _{IL}	LOW-level input voltage	A or B port	V _{CC(A)} =1.65V to 3.6V; V _{CC(B)} =2.3V to 5.5V	-	-	0.15	V
		OE input	V _{CC(A)} =1.65V to 3.6V; V _{CC(B)} =2.3V to 5.5V	-	-	0.35V _{CC(A)}	V
V _{OH}	HIGH-level output voltage	A port; I _o =-20uA; V _i ≥V _{CC(B)} -0.4V	V _{CC(A)} =1.65V to 3.6V; V _{CC(B)} =2.3V to 5.5V	0.67V _{CC(A)}	-	-	V
		B port; I _o =-20uA; V _i ≥V _{CC(A)} -0.2V	V _{CC(A)} =1.65V to 3.6V; V _{CC(B)} =2.3V to 5.5V	0.67V _{CC(B)}	-	-	V
V _{OL}	LOW-level output voltage	A port; V _i ≤0.15V; V _{CC(B)} =1.65V to 5.5V	V _{CC(A)} =1.65V; I _o =-220uA	-	-	0.4	V
			V _{CC(A)} =2.3V; I _o =-300uA	-	-	0.4	V
			V _{CC(A)} =3.0V; I _o =-400uA	-	-	0.55	V
		B port; V _i ≤0.15V; V _{CC(A)} =1.65V to 3.6V	V _{CC(B)} =1.65V; I _o =-220uA	-	-	0.4	V
			V _{CC(B)} =2.3V; I _o =-300uA	-	-	0.4	V
			V _{CC(B)} =3.0V; I _o =-400uA	-	-	0.55	V
			V _{CC(B)} =4.5V; I _o =-620uA	-	-	0.55	V
I _I	Input leakage current	OE input; V _i =0V to 3.6V; V _{CC(A)} =1.65V to 3.6V; V _{CC(B)} =2.3V to 5.5V	-	-	±2	uA	
I _{oz}	OFF-state output current	A or B port; V _o =0V or V _{CCo} ; V _{CC(A)} =1.65V to 3.6V; V _{CC(B)} =2.3V to 5.5V	-	-	±2	uA	
I _{OFF}	Power-off leakage current	A port; V _i or V _o =0V to 3.6V; V _{CC(A)} =0V; V _{CC(B)} =0V to 5.5V	-	-	±2	uA	
		B port; V _i or V _o =0V to 3.6V; V _{CC(B)} =0V; V _{CC(A)} =0V to 5.5V	-	-	±2	uA	
I _{CC}	Supply current	OE=0V or V _{CC(A)} ; A _n , B _n open					
		I _{CC(A)}	V _{CC(A)} =1.65V; V _{CC(B)} =1.65V to 5.5V	-20	-	20	uA
			V _{CC(A)} =1.65V to 3.6V; V _{CC(B)} =2.3V to 5.5V	-20	-	20	uA
			V _{CC(A)} =3.6V; V _{CC(B)} =0V	-	-	20	uA
			V _{CC(A)} =0V; V _{CC(B)} =5.5V	-20	-	-	uA
		I _{CC(B)}	V _{CC(A)} =1.65V; V _{CC(B)} =1.65V to 5.5V	-	-	45	uA
			V _{CC(A)} =1.65V to 3.6V; V _{CC(B)} =2.3V to 5.5V	-	-	45	uA
			V _{CC(A)} =3.6V; V _{CC(B)} =0V	-20	-	-	uA
			V _{CC(A)} =0V; V _{CC(B)} =5.5V	-	-	20	uA
		I _{CC(A)} +I _{CC(B)}	V _{CC(A)} =1.65V; V _{CC(B)} =1.65V to 5.5V	-	-	65	uA

			$V_{CC(A)}=1.65V$ to $3.6V$; $V_{CC(B)}=2.3V$ to $5.5V$	-	-	65	μA
--	--	--	---	---	---	----	---------

Note:

- (1) $V_{CC(A)}$ must be less than or equal to $V_{CC(B)}$.
- (2) V_{CCO} is the supply voltage associated with the output.

7.3.3 DC Characteristics 3
 $T_{amb}=-40^{\circ}C$ to $+125^{\circ}C$, voltages are referenced to GND (ground=0V), unless otherwise specified.

SYMBOL	PARAMETER	CONDITIONS		MIN.	TYP.	MAX.	UNIT
V_{IH}	HIGH-level input voltage	A port	$V_{CC(A)}=1.65V$ to $1.95V$; $V_{CC(B)}=2.3V$ to $5.5V$	$V_{CC(A)}-0.2$	-	-	V
			$V_{CC(A)}=2.3V$ to $3.6V$; $V_{CC(B)}=2.3V$ to $5.5V$	$V_{CC(A)}-0.4$	-	-	V
		B port	$V_{CC(A)}=1.65V$ to $3.6V$; $V_{CC(B)}=2.3V$ to $5.5V$	$V_{CC(B)}-0.4$	-	-	V
		OE input	$V_{CC(A)}=1.65V$ to $3.6V$; $V_{CC(B)}=2.3V$ to $5.5V$	$0.65V_{CC(A)}$	-	-	V
V_{IL}	LOW-level input voltage	A or B port	$V_{CC(A)}=1.65V$ to $3.6V$; $V_{CC(B)}=2.3V$ to $5.5V$	-	-	0.15	V
		OE input	$V_{CC(A)}=1.65V$ to $3.6V$; $V_{CC(B)}=2.3V$ to $5.5V$	-	-	$0.35V_{CC(A)}$	V
V_{OH}	HIGH-level output voltage	A port; $I_o=-20\mu A$; $V_i \geq V_{CC(B)}-0.4V$	$V_{CC(A)}=1.65V$ to $3.6V$; $V_{CC(B)}=2.3V$ to $5.5V$	$0.67V_{CC(A)}$	-	-	V
		B port; $I_o=-20\mu A$; $V_i \geq V_{CC(A)}-0.2V$	$V_{CC(A)}=1.65V$ to $3.6V$; $V_{CC(B)}=2.3V$ to $5.5V$	$0.67V_{CC(B)}$	-	-	V
V_{OL}	LOW-level output voltage	A port; $V_i \leq 0.15V$; $V_{CC(B)}=1.65V$ to $5.5V$	$V_{CC(A)}=1.65V$; $I_o=-220\mu A$	-	-	0.4	V
			$V_{CC(A)}=2.3V$; $I_o=-300\mu A$	-	-	0.4	V
			$V_{CC(A)}=3.0V$; $I_o=-400\mu A$	-	-	0.55	V
		B port; $V_i \leq 0.15V$; $V_{CC(A)}=1.65V$ to $3.6V$	$V_{CC(B)}=1.65V$; $I_o=-220\mu A$	-	-	0.4	V
			$V_{CC(B)}=2.3V$; $I_o=-300\mu A$	-	-	0.4	V
			$V_{CC(B)}=3.0V$; $I_o=-400\mu A$	-	-	0.55	V
			$V_{CC(B)}=4.5V$; $I_o=-620\mu A$	-	-	0.55	V
		I_i	Input leakage current	OE input; $V_i=0V$ to $3.6V$; $V_{CC(A)}=1.65V$ to $1.95V$; $V_{CC(B)}=2.3V$ to $5.5V$		-	-
I_{OZ}	OFF-state output current	A or B port; $V_o=0V$ or V_{CCO} ; $V_{CC(A)}=1.65V$ to $1.95V$; $V_{CC(B)}=2.3V$ to $5.5V$		-	-	± 12	μA
I_{OFF}	Power-off leakage current	A port; V_i or $V_o=0V$ to $3.6V$; $V_{CC(A)}=0V$; $V_{CC(B)}=0V$ to $5.5V$		-	-	± 12	μA
		B port; V_i or $V_o=0V$ to $3.6V$; $V_{CC(B)}=0V$; $V_{CC(A)}=0V$ to $5.5V$		-	-	± 12	μA
I_{CC}	Supply current	OE=0V or $V_{CC(A)}$; An, Bn open					
		$I_{CC(A)}$	$V_{CC(A)}=1.65V$; $V_{CC(B)}=1.65V$ to $5.5V$	-5	-	20	μA
			$V_{CC(A)}=1.65V$ to $3.6V$; $V_{CC(B)}=2.3V$ to $5.5V$	-2	-	45	μA
			$V_{CC(A)}=3.6V$; $V_{CC(B)}=0V$	-	-	20	μA
			$V_{CC(A)}=0V$; $V_{CC(B)}=5.5V$	-1	-	-	μA
		$I_{CC(B)}$	$V_{CC(A)}=1.65V$; $V_{CC(B)}=1.65V$ to $5.5V$	-	-	45	μA

			$V_{CC(A)}=1.65V$ to $3.6V$; $V_{CC(B)}=2.3V$ to $5.5V$	-	-	60	uA
			$V_{CC(A)}=3.6V$; $V_{CC(B)}=0V$	-1	-	-	uA
			$V_{CC(A)}=0V$; $V_{CC(B)}=5.5V$	-	-	20	uA
		$I_{CC(A)}+I_{CC(B)}$	$V_{CC(A)}=1.65V$; $V_{CC(B)}=1.65V$ to $5.5V$	-	-	65	uA
			$V_{CC(A)}=1.65V$ to $3.6V$; $V_{CC(B)}=2.3V$ to $5.5V$	-	-	65	uA

Note:

- (1) $V_{CC(A)}$ must be less than or equal to $V_{CC(B)}$.
- (2) V_{CCO} is the supply voltage associated with the output.

7.3.4 AC Characteristics 1
 $T_{amb}=25^{\circ}C$, voltages are referenced to GND (ground=0V), unless otherwise specified.

SYMBOL	PARAMETER	CONDITIONS	$V_{CC(B)}$				UNIT
			$1.8V\pm 0.1V$	$2.5V\pm 0.2V$	$3.3V\pm 0.3V$	$5.0V\pm 0.5V$	
t_{PHL}	HIGH to LOW propagation delay	A to B	6.5	5.9	5.7	5.5	ns
t_{PLH}	LOW to HIGH propagation delay	A to B	7.1	6.3	6.2	6.6	ns
t_{PHL}	HIGH to LOW propagation delay	B to A	6.2	5.4	5.1	5	ns
t_{PLH}	LOW to HIGH propagation delay	B to A	5.6	4.1	3.6	3.2	ns
t_{en}	Enable time	OE to A; B ⁽¹⁾	200	200	200	200	ns
t_{dis}	Disable time	OE to A; No external load ⁽¹⁾⁽²⁾	12	12	12	12	ns
		OE to B; No external load ⁽²⁾	12	12	12	12	ns
		OE to A; See Figure 8-3	90	90	90	90	ns
		OE to B; See Figure 8-3	95	75	100	75	ns
t_{TLH}	LOW to HIGH output transition time	A port	6.5	5.2	4.8	4.4	ns
		B port	6.6	4.3	2.1	1.5	ns
t_{THL}	HIGH to LOW output transition time	A port	5.8	4.8	4.3	3.8	ns
		B port	3.6	2.2	1.8	1.5	ns
$t_{sk(o)}$	Output skew time	Between channels ⁽³⁾	1	1	1	1	ns
t_w	Pulse width	Data inputs	20	16.7	16.7	16.7	ns
f_{data}	Data rate	-	50	50	50	50	Mbps

- (1) t_{en} is the same as t_{PZL} and t_{PZH} ; t_{dis} is the same as t_{PLZ} and t_{PHZ} .
- (2) These values are guaranteed by design.
- (3) Skew between any two outputs of the same package switching in the same direction.

7.3.5 AC Characteristics 2

T_{amb}=-40°C to +85°C, voltages are referenced to GND (ground=0V), unless otherwise specified.

SYMBOL	PARAMETER	CONDITIONS	V _{CC(B)}								UNIT
			1.8V±0.15V		2.5V±0.2V		3.3V±0.3V		5.0V±0.5V		
			MIN.	MAX	MIN.	MAX	MIN.	MAX	MIN.	MAX	
V_{CC(A)}=1.8V±0.15V											
t _{PHL}	HIGH to LOW propagation delay	A to B	-	9.7	-	7.3	-	6.5	-	5.9	ns
t _{PLH}	LOW to HIGH propagation delay	A to B	-	11.3	-	8.4	-	7.4	-	6.5	ns
t _{PHL}	HIGH to LOW propagation delay	B to A	-	9.8	-	8.0	-	7.4	-	7.0	ns
t _{PLH}	LOW to HIGH propagation delay	B to A	-	10.2	-	7.0	-	5.8	-	5.0	ns
t _{en}	Enable time	OE to A; B ⁽¹⁾	-	200	-	200	-	200	-	200	ns
t _{dis}	Disable time	OE to A; No external load ⁽¹⁾⁽²⁾	-	13	-	13	-	13	-	13	ns
		OE to B; No external load ⁽²⁾	-	16	-	13	-	13	-	13	ns
		OE to A; See Figure 8-3	-	140	-	140	-	140	-	145	ns
		OE to B; See Figure 8-3	-	165	-	125	-	175	-	125	ns
t _{TLH}	LOW to HIGH output transition time	A port	2.2	11.9	2.0	8.6	1.9	7.8	1.9	7.2	ns
		B port	2.8	12.2	1.8	7.7	1.2	5.3	0.7	2.9	ns
t _{THL}	HIGH to LOW output transition time	A port	1.8	8.8	1.3	6.6	0.9	5.7	0.6	4.9	ns
		B port	1.3	8.3	1.0	5.4	0.9	3.9	0.7	3.0	ns
t _{sk(o)}	Output skew time	Between channels ⁽³⁾	-	1	-	1	-	1	-	1	ns
t _w	Pulse width	Data inputs	22.2	-	16.7	-	16.7	-	16.7	-	ns
f _{data}	Data rate	-	-	45	-	50	-	50	-	50	Mbps
V_{CC(A)}=2.5V±0.2V											
t _{PHL}	HIGH to LOW propagation delay	A to B	-	-	-	6.2	-	5.3	-	4.7	ns
t _{PLH}	LOW to HIGH propagation delay	A to B	-	-	-	6.8	-	5.9	-	5.2	ns
t _{PHL}	HIGH to LOW propagation delay	B to A	-	-	-	5.9	-	4.8	-	4.2	ns
t _{PLH}	LOW to HIGH propagation delay	B to A	-	-	-	6.2	-	4.6	-	3.6	ns
t _{en}	Enable time	OE to A; B ⁽¹⁾	-	-	-	200	-	200	-	200	ns
t _{dis}	Disable time	OE to A; No external	-	-	-	9	-	9	-	9	ns

		load ⁽¹⁾⁽²⁾									
		OE to B; No external load ⁽²⁾	-	-	-	11	-	9	-	9	ns
		OE to A	-	-	-	105	-	105	-	105	ns
		OE to B	-	-	-	125	-	175	-	120	ns
t _{TLH}	LOW to HIGH output transition time	A port	-	-	1.7	7.3	1.7	6.4	1.8	5.8	ns
		B port	-	-	1.8	7.3	1.3	5.4	0.8	3.3	ns
t _{THL}	HIGH to LOW output transition time	A port	-	-	1.3	5.7	0.8	4.7	0.6	3.8	ns
		B port	-	-	1.1	5.4	0.9	4.1	0.7	3.0	ns
t _{sk(o)}	Output skew time	Between channels ⁽³⁾	-	-	-	1	-	1.2	-	1	ns
t _w	Pulse width	Data inputs	-	-	14	-	11	-	11	-	ns
f _{data}	Data rate	-	-	-	-	50	-	50	-	50	Mbps
V_{CC(A)}=3.3V±0.3V											
t _{PHL}	HIGH to LOW propagation delay	A to B	-	-	-	-	-	4.9	-	4.2	ns
t _{PLH}	LOW to HIGH propagation delay	A to B	-	-	-	-	-	5.2	-	4.6	ns
t _{PHL}	HIGH to LOW propagation delay	B to A	-	-	-	-	-	4.7	-	3.8	ns
t _{PLH}	LOW to HIGH propagation delay	B to A	-	-	-	-	-	4.7	-	4.3	ns
t _{en}	Enable time	OE to A; B ⁽¹⁾	-	-	-	-	-	200	-	200	ns
t _{dis}	Disable time	OE to A; No external load ⁽¹⁾⁽²⁾	-	-	-	-	-	8	-	8	ns
		OE to B; No external load ⁽²⁾	-	-	-	-	-	8	-	8	ns
		OE to A	-	-	-	-	-	150	-	150	ns
		OE to B	-	-	-	-	-	170	-	120	ns
t _{TLH}	LOW to HIGH output transition time	A port	-	-	-	-	1.6	5.7	1.8	5.0	ns
		B port	-	-	-	-	1.5	5.4	0.9	3.9	ns
t _{THL}	HIGH to LOW output transition time	A port	-	-	-	-	1.0	4.5	0.6	3.5	ns
		B port	-	-	-	-	1.0	4.2	0.8	3.1	ns
t _{sk(o)}	Output skew time	Between channels ⁽³⁾	-	-	-	-	-	1	-	1	ns
t _w	Pulse width	Data inputs	-	-	-	-	11	-	9	-	ns
f _{data}	Data rate	-	-	-	-	-	-	50	-	50	Mbps

(1) t_{en} is the same as t_{PZL} and t_{PZH}; t_{dis} is the same as t_{PLZ} and t_{PHZ}.

(2) These values are guaranteed by design.

(3) Skew between any two outputs of the same package switching in the same direction.

7.3.6 AC Characteristics 3

Tamb=-40°C to +125°C, voltages are referenced to GND (ground=0V), unless otherwise specified.

SYMBOL	PARAMETER	CONDITIONS	V _{CC(B)}								UNIT
			1.8V±0.15V		2.5V±0.2V		3.3V±0.3V		5.0V±0.5V		
			MIN.	MAX	MIN.	MAX	MIN.	MAX	MIN.	MAX	
V_{CC(A)}=1.8V±0.15V											
t _{PHL}	HIGH to LOW propagation delay	A to B	-	12.1	-	9.1	-	8.1	-	7.4	ns
t _{PLH}	LOW to HIGH propagation delay	A to B	-	14.1	-	10.5	-	9.3	-	8.1	ns
t _{PHL}	HIGH to LOW propagation delay	B to A	-	12.3	-	10.0	-	9.3	-	8.8	ns
t _{PLH}	LOW to HIGH propagation delay	B to A	-	12.8	-	8.8	-	7.3	-	6.3	ns
t _{en}	Enable time	OE to A; B ⁽¹⁾	-	200	-	200	-	200	-	200	ns
t _{dis}	Disable time	OE to A; No external load ⁽¹⁾⁽²⁾	-	14	-	14	-	14	-	14	ns
		OE to B; No external load ⁽²⁾	-	17	-	14	-	14	-	14	ns
		OE to A; See Figure 8-3	-	140	-	140	-	140	-	145	ns
		OE to B; See Figure 8-3	-	165	-	125	-	175	-	125	ns
t _{TLH}	LOW to HIGH output transition time	A port	2.2	14.9	2.0	10.8	1.9	9.8	1.9	9.0	ns
		B port	2.8	15.3	1.8	9.6	1.2	6.6	0.7	3.6	ns
t _{THL}	HIGH to LOW output transition time	A port	1.8	11.0	1.3	8.3	0.9	7.1	0.6	6.1	ns
		B port	1.3	10.4	1.0	6.8	0.9	4.9	0.7	3.8	ns
t _{sk(o)}	Output skew time	Between channels ⁽³⁾	-	1.1	-	1.1	-	1.1	-	1.1	ns
t _w	Pulse width	Data inputs	25	-	20	-	20	-	20	-	ns
f _{data}	Data rate	-	-	40	-	50	-	50	-	50	Mbps
V_{CC(A)}=2.5V±0.2V											
t _{PHL}	HIGH to LOW propagation delay	A to B	-	-	-	7.8	-	6.6	-	5.9	ns
t _{PLH}	LOW to HIGH propagation delay	A to B	-	-	-	8.5	-	7.4	-	6.5	ns
t _{PHL}	HIGH to LOW propagation delay	B to A	-	-	-	7.4	-	6.0	-	5.3	ns
t _{PLH}	LOW to HIGH propagation delay	B to A	-	-	-	7.8	-	5.8	-	4.5	ns
t _{en}	Enable time	OE to A; B ⁽¹⁾	-	-	-	200	-	200	-	200	ns
t _{dis}	Disable time	OE to A; No external	-	-	-	10	-	10	-	10	ns

		load ⁽¹⁾⁽²⁾									
		OE to B; No external load ⁽²⁾	-	-	-	12	-	10	-	10	ns
		OE to A	-	-	-	105	-	105	-	105	ns
		OE to B	-	-	-	125	-	175	-	120	ns
t _{TLH}	LOW to HIGH output transition time	A port	-	-	1.7	9.1	1.7	8.0	1.8	7.3	ns
		B port	-	-	1.8	9.1	1.3	6.8	0.9	4.1	ns
t _{THL}	HIGH to LOW output transition time	A port	-	-	1.3	7.1	0.8	5.9	0.6	4.8	ns
		B port	-	-	1.1	6.8	0.9	5.1	0.7	3.8	ns
t _{sk(o)}	Output skew time	Between channels ⁽³⁾	-	-	-	1.1	-	1.3	-	1.1	ns
t _w	Pulse width	Data inputs	-	-	16.7	-	12.5	-	12.5	-	ns
f _{data}	Data rate	-	-	-	-	50	-	50	-	50	Mbps
V_{CC(A)}=3.3V±0.3V											
t _{PHL}	HIGH to LOW propagation delay	A to B	-	-	-	-	-	6.1	-	5.3	ns
t _{PLH}	LOW to HIGH propagation delay	A to B	-	-	-	-	-	6.5	-	5.8	ns
t _{PHL}	HIGH to LOW propagation delay	B to A	-	-	-	-	-	5.9	-	4.8	ns
t _{PLH}	LOW to HIGH propagation delay	B to A	-	-	-	-	-	5.9	-	5.4	ns
t _{en}	Enable time	OE to A; B ⁽¹⁾	-	-	-	-	-	200	-	200	ns
t _{dis}	Disable time	OE to A; No external load ⁽¹⁾⁽²⁾	-	-	-	-	-	9	-	9	ns
		OE to B; No external load ⁽²⁾	-	-	-	-	-	9	-	9	ns
		OE to A	-	-	-	-	-	150	-	150	ns
		OE to B	-	-	-	-	-	170	-	120	ns
t _{TLH}	LOW to HIGH output transition time	A port	-	-	-	-	1.6	7.1	1.8	6.3	ns
		B port	-	-	-	-	1.5	6.8	0.9	4.9	ns
t _{THL}	HIGH to LOW output transition time	A port	-	-	-	-	1.0	5.6	0.7	4.4	ns
		B port	-	-	-	-	1.0	5.3	0.8	3.9	ns
t _{sk(o)}	Output skew time	Between channels ⁽³⁾	-	-	-	-	-	1.1	-	1.1	ns
t _w	Pulse width	Data inputs	-	-	-	-	13	-	10	-	ns
f _{data}	Data rate	-	-	-	-	-	-	50	-	50	Mbps

(1) t_{en} is the same as t_{PZL} and t_{PZH}; t_{dis} is the same as t_{PLZ} and t_{PHZ}.

(2) These values are guaranteed by design.

(3) Skew between any two outputs of the same package switching in the same direction.

8 Detailed Description

8.1 Overview

The CJTS010X is an 4-bit, dual supply transceiver that enables bidirectional level translation. The device can be used as two 2-bit transceivers or as a 4-bit transceiver. It features four 2-bit input-output ports (nAn and nBn), a direction control input (nDIR), a output enable input (/nOE) and dual supply pins (V_{CC(A)} and V_{CC(B)}). Both V_{CC(A)} and V_{CC(B)} can be supplied at any voltage between 0.8V and 3.6V making the device suitable for translating between any of the low voltage nodes (0.8V, 1.2V, 1.5V, 1.8V, 2.5V and 3.3V). Pins nAn, /nOE and nDIR are referenced to V_{CC(A)} and pins nBn are referenced to V_{CC(B)}. A HIGH on nDIR allows transmission from nAn to nBn and a LOW on nDIR allows transmission from nBn to nAn. The output enable input (/nOE) can be used to disable the outputs so the buses are effectively isolated.

The device is fully specified for partial power-down applications using I_{OFF}. The I_{OFF} circuitry disables the output, preventing any damaging backflow current through the device when it is powered down. In suspend mode when either V_{CC(A)} or V_{CC(B)} are at GND level, both nAn and nBn are in the high-impedance OFF-state.

8.2 Functional Block Diagram

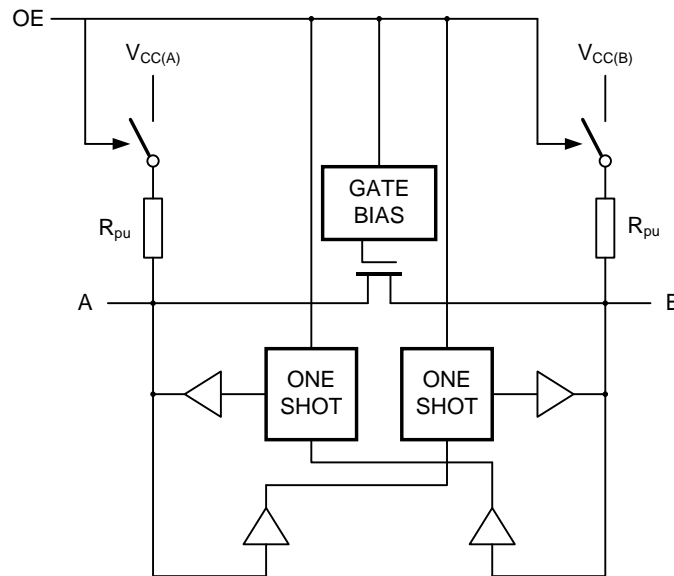

8.3 Function Table

SUPPLY VOLTAGE		INPUT	INPUT/OUTPUT	
V _{CC(A)}	V _{CC(B)}	OE	A	B
1.65V to 3.6V	2.3V to 5.5V	L	Z	Z
1.65V to 3.6V	2.3V to 5.5V	H	Input or output	Output or input
GND	2.3V to 5.5V	X	Z	Z
1.65V to 3.6V	GND	X	Z	Z

Note:

- (1) H=HIGH voltage level; L=LOW voltage level; X=don't care; Z=high-impedance OFF-state.
- (2) V_{CC(A)} must be less than or equal to V_{CC(B)}.

8.4 Testing Circuit

8.4.1 AC Testing Circuit

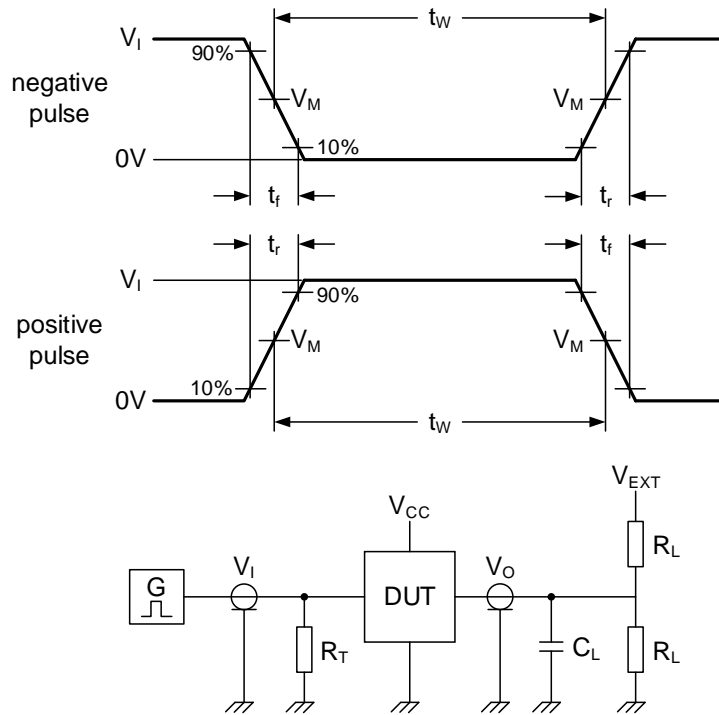

Figure 8-1 Test circuit for measuring switching times

All input pulses are supplied by generators having the following characteristics: $PRR \leq 10\text{MHz}$; $Z_o = 50\Omega$; $dV/dt \geq 1.0\text{V/ns}$.

R_L =Load resistance.

C_L =Load capacitance including jig and probe capacitance.

V_{EXT} =External voltage for measuring switching times.

8.4.2 AC Testing Waveforms

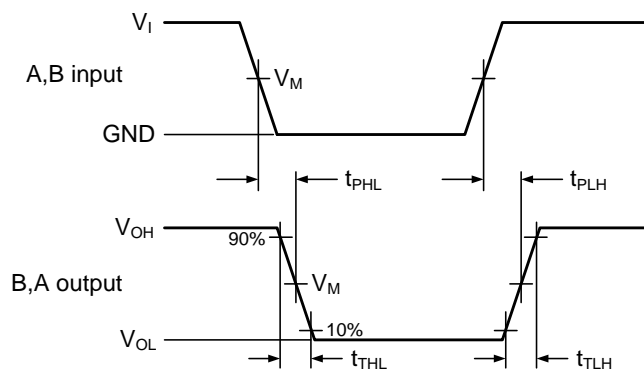

Figure 8-2 The data input (A, B) to data output (B, A) propagation delay times

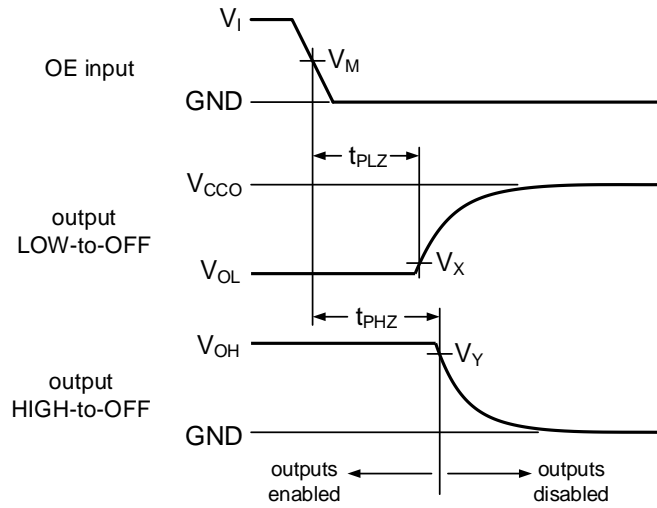
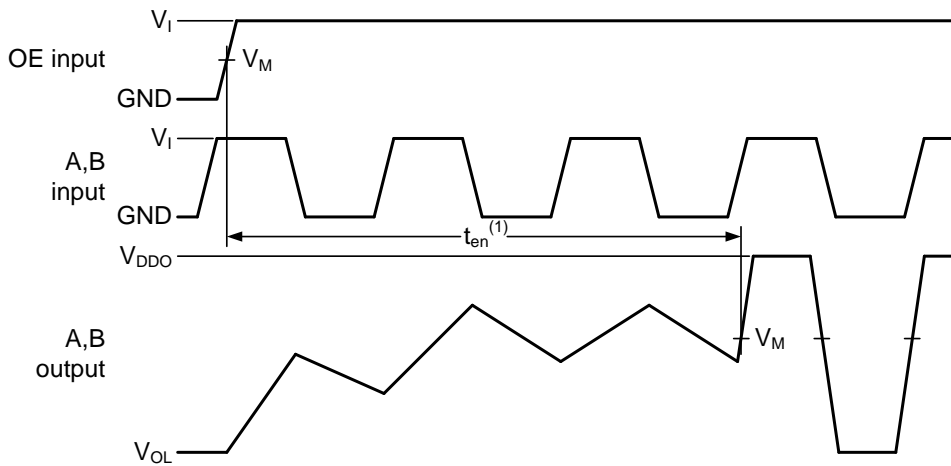

Figure 8-3 Disable times



(1) The enable time (t_{en}) indicates the amount of time the user must allow for one one-shot circuitry to become operational after OE is taken HIGH. See also Section 5.6.

Figure 8-4 Enable times

8.4.3 Measurement Points

SUPPLY VOLTAGE	INPUT	OUTPUT		
		V_M	V_X	V_Y
1.8V±0.15V	0.5V _{CCI}	0.5V _{CCO}	V _{OL} +0.15V	V _{OH} -0.15V
2.5V±0.2V	0.5V _{CCI}	0.5V _{CCO}	V _{OL} +0.15V	V _{OH} -0.15V
3.3V±0.3V	0.5V _{CCI}	0.5V _{CCO}	V _{OL} +0.3V	V _{OH} -0.3V
5.0V±0.5V	0.5V _{CCI}	0.5V _{CCO}	V _{OL} +0.3V	V _{OH} -0.3V

Note:

- (1) V_{CCI} is the supply voltage associated with the input.
- (2) V_{CCO} is the supply voltage associated with the output.

8.4.4 Test Data

SUPPLY VOLTAGE		INPUT		LOAD		V _{EXT}		
V _{CC(A)}	V _{CC(B)}	V _I	$\Delta t/\Delta V$	C _L	R _L	t _{PLH} , t _{PHL}	t _{PZH} , t _{PHZ}	t _{PZL} , t _{PLZ}
1.65V to 3.6V	2.3V to 5.5V	V _{CCI}	$\leq 1.0\text{ns/V}$	15pF	50k Ω , 1M Ω	Open	Open	2V _{CCO}

Note:

- (1) V_{CCI} is the supply voltage associated with the input.
- (2) For measuring data rate, pulse width, propagation delay and output rise and fall measurements, R_L=1M Ω .
For measuring enable and disable times, R_L=50K Ω .
- (3) V_{CCO} is the supply voltage associated with the output.

9 Typical Application Circuit and Application Note

9.1 Voltage Level-translation Applications

The CJTS010X can be used in point-to-point applications to interface between devices or systems operating at different supply voltages. The device is primarily targeted at I²C or 1-wire which use open-drain drivers, it may also be used in applications where push-pull drivers are connected to the ports, however the CJTB010X may be more suitable.

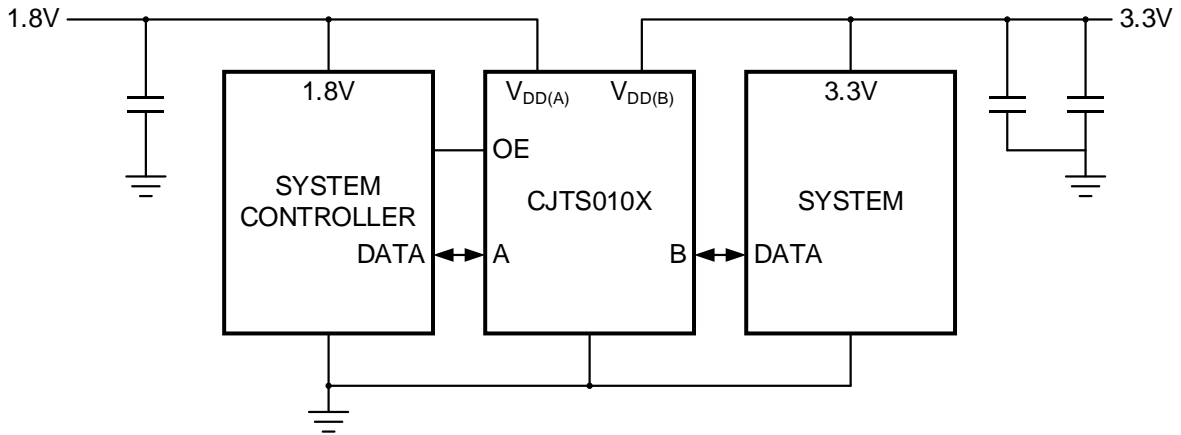

Figure 9-1 Typical operating circuit

9.2 Architecture

The architecture of the CJTS010X is shown in Figure 9-2. The device does not require an extra input signal to control the direction of data flow from A to B or B to A.

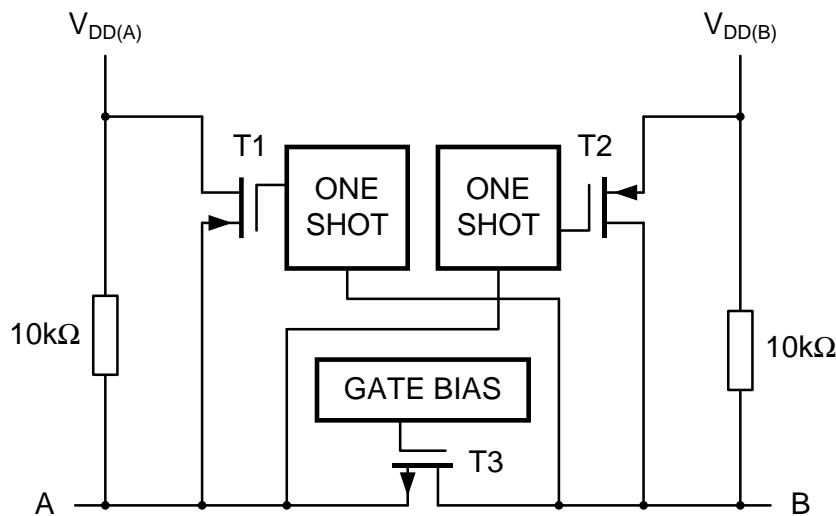

Figure 9-2 Architecture of CJTS010X I/O cell (one channel)

The CJTS010X is a "switch" type voltage translator, it employs two key circuits to enable voltage translation:

1. A pass-gate transistor (N-channel) that ties the ports together.
2. An output edge-rate accelerator that detects and accelerates rising edges on the I/O pins.

The gate bias voltage of the pass gate transistor (T3) is set at approximately one threshold voltage above the V_{CC} level of the low-voltage side. During a LOW-to-HIGH transition the output one-shot accelerates the output transition by switching on the PMOS transistors (T1, T2) bypassing the 10KΩ pull-up resistors and increasing current drive capability. The one-shot is activated once the input transition reaches approximately V_{CC}/2; it is de-activated approximately 50ns

after the output reaches $V_{CCO}/2$. During the acceleration time the driver output resistance is between approximately 50Ω and 70Ω. To avoid signal contention and minimize dynamic I_{DD} , the user should wait for the one-shot circuit to turn-off before applying a signal in the opposite direction. Pull-up resistors are included in the device for DC current sourcing capability.

9.3 Input Driver Requirements

As the CJTS010X is a switch type translator, properties of the input driver directly effect the output signal. The external open-drain or push-pull driver applied to an I/O determines the static current sinking capability of the system; the max data rate, HIGH-to-LOW output transition time (t_{THL}) and propagation delay (t_{PHL}) are dependent upon the output impedance and edge-rate of the external driver. The limits provided for these parameters in the datasheet assume a driver with output impedance below 50Ω is used.

9.4 Output Load Considerations

The maximum lumped capacitive load that can be driven is dependant upon the one-shot pulse duration. In cases with very heavy capacitive loading there is a risk that the output will not reach the positive rail within the one-shot pulse duration. To avoid excessive capacitive loading and to ensure correct triggering of the one-shot it's recommended to use short trace lengths and low capacitance connectors on CJTS010X PCB layouts. To ensure low impedance termination and avoid output signal oscillations and one-shot re-triggering, the length of the PCB trace should be such that the round trip delay of any reflection is within the one-shot pulse duration (approximately 50ns).

9.5 Power up

During operation $V_{CC(A)}$ must never be higher than $V_{CC(B)}$, however during power-up $V_{CC(A)} \geq V_{CC(B)}$ does not damage the device, so either power supply can be ramped up first. There is no special power-up sequencing required. The CJTS010X includes circuitry that disables all output ports when either $V_{CC(A)}$ or $V_{CC(B)}$ is switched off.

9.6 Enable and Disable

An output enable input (OE) is used to disable the device. Setting OE=LOW causes all I/Os to assume the high-impedance OFF-state. The disable time (t_{dis} with no external load) indicates the delay between when OE goes LOW and when outputs actually become disabled. The enable time (t_{en}) indicates the amount of time the user must allow for one one-shot circuitry to become operational after OE is taken HIGH. To ensure the high-impedance OFF-state during power-up or power-down, pin OE should be tied to GND through a pull-down resistor, the minimum value of the resistor is determined by the current-sourcing capability of the driver.

9.7 Pull-up or Pull-down Resistors on I/O Lines

The CJTS010X has the pull-up resistors dynamically change value based on whether a low or a high is being passed through the I/O line. Each A-port I/O has a pull-up resistor (R_{PUA}) to V_{CCA} and each B-port I/O has a pull-up resistor (R_{PUB}) to V_{CCB} . R_{PUA} and R_{PUB} have a value of 40kΩ when the output is driving LOW. R_{PUA} and R_{PUB} have a value of 4kΩ when the output is driving HIGH. R_{PUA} and R_{PUB} are disabled when OE=LOW. This feature provides lower static power consumption (when the I/Os are passing a LOW) and supports lower V_{OL} values for the same size pass-gate transistor and helps improve simultaneous switching performance.

10 Mechanical Information

10.1 SOT-23-6L Mechanical Information

10.1.1 SOT-23-6L Outline Dimensions

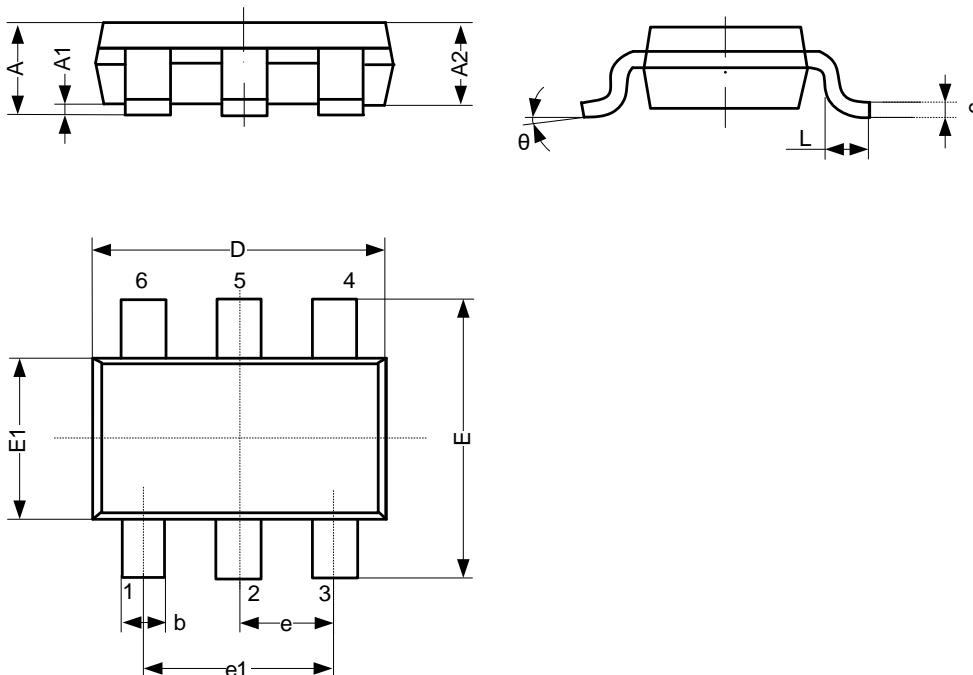

SYMBOL	Dimensions In Millimeters		
	Min.	Typ.	Max.
A	-	-	1.25
A1	0.00	-	0.12
A2	1.00	-	1.20
b	0.30	-	0.50
c	0.10	-	0.20
D	2.82	-	3.02
E	2.60	-	3.00
E1	1.50	-	1.70
e	0.95 BSC		
e1	1.80	-	2.00
L	0.30	-	0.60
θ	0°	-	8°
Unit: mm			

10.2 SOT-363 Mechanical Information

10.2.1 SOT-363 Outline Dimensions

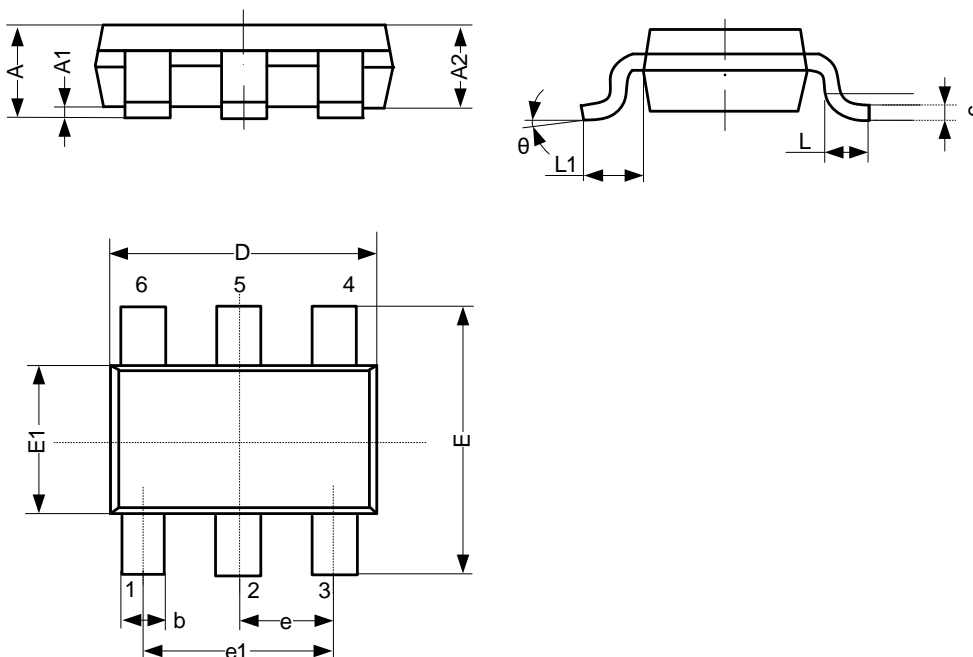

SYMBOL	Dimensions In Millimeters		
	Min.	Typ.	Max.
A	0.90	-	1.10
A1	0.00	-	0.10
A2	0.90	-	1.00
b	0.15	-	0.35
c	0.11	-	0.175
D	2.00	-	2.20
E	2.15	-	2.45
E1	1.15	-	1.35
e	0.65 BSC		
e1	1.20	-	1.40
L	0.26	-	0.46
L1	-	0.525	-
θ	0°	-	8°
Unit: mm			

10.3 TSSOP8(3x3) Mechanical Information

10.3.1 TSSOP8(3x3) Outline Dimensions

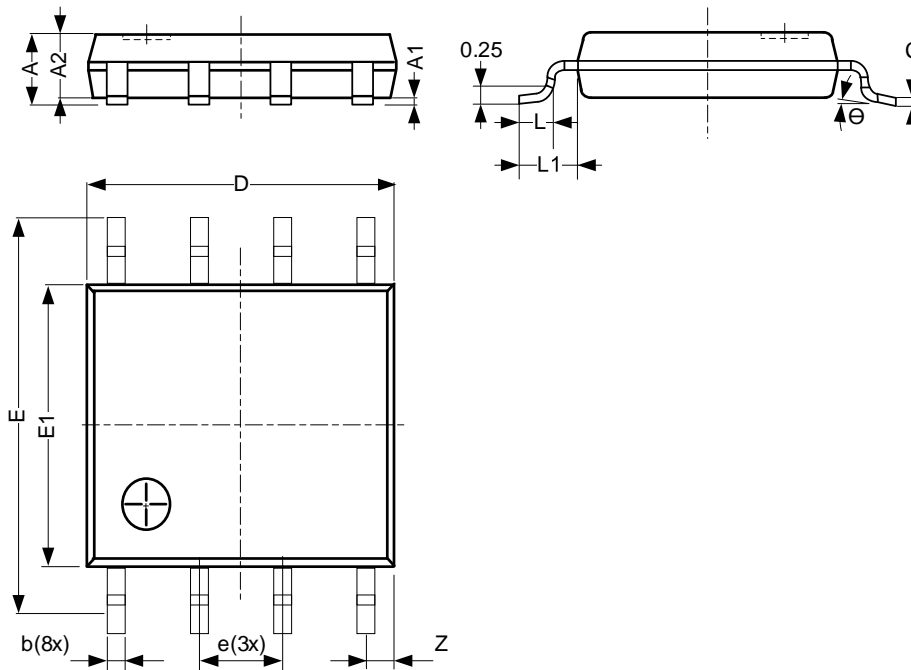

SYMBOL	Dimensions In Millimeters		
	Min.	Typ.	Max.
A	-	-	1.10
A1	0	-	0.15
A2	0.75	-	0.95
b	0.22	-	0.38
c	0.08	-	0.18
D	2.90	-	3.10
E	3.90	-	4.10
E1	2.90	-	3.10
e	0.65 BSC		
L	0.33	-	0.47
L1	-	0.50	-
Z	0.35	-	0.70
Θ	0°	-	8°
Unit: mm			

10.4 VSSOP8 Mechanical Information

10.4.1 VSSOP8 Outline Dimensions

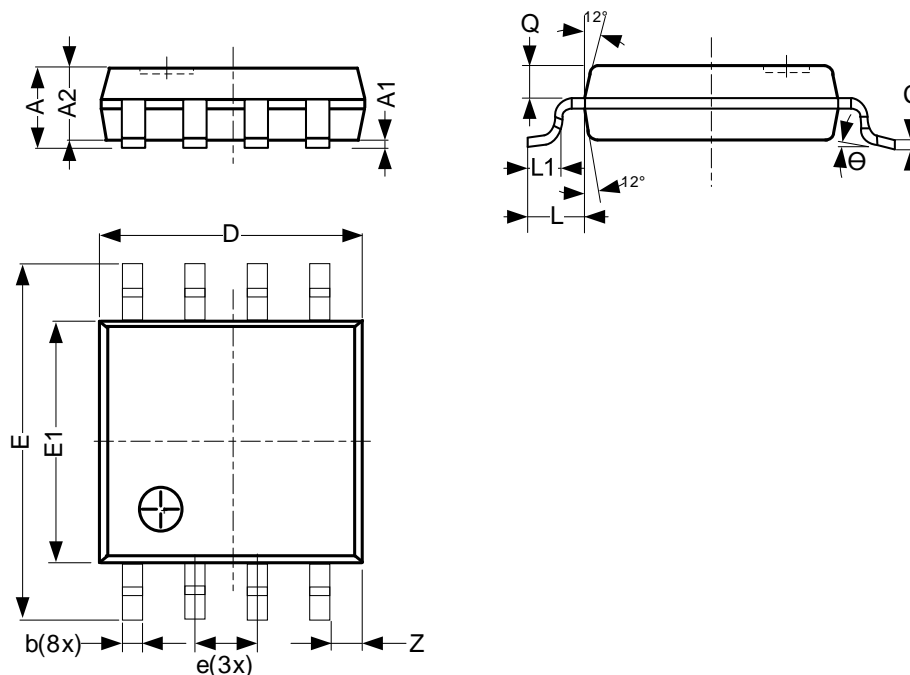

SYMBOL	Dimensions In Millimeters		
	Min.	Typ.	Max.
A	-	-	1.00
A1	0	-	0.15
A2	0.60	-	0.85
Q	0.19	-	0.21
b	0.17	-	0.27
c	0.08	-	0.23
D	1.90	-	2.10
E	3.00	-	3.20
E1	2.20	-	2.40
e	0.50 BSC		
L	-	0.40	-
L1	0.15	-	0.40
Z	0.10	-	0.40
Θ	0°	-	8°
Unit: mm			

10.5 DFN1.35x1-8L Mechanical Information

10.5.1 DFN1.35x1-8L Outline Dimensions

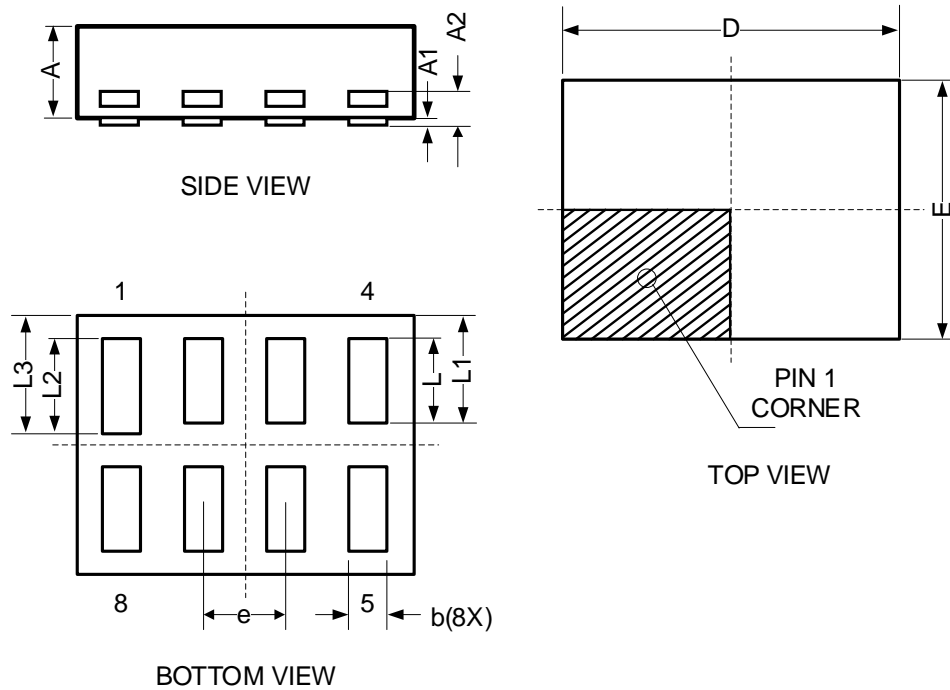

SYMBOL	Dimensions In Millimeters		
	Min.	Typ.	Max.
A	0.28	-	0.32
A1	0.00	-	0.05
A2	-	0.10	-
b	0.11	-	0.21
D	-	1.35	-
E	-	1.00	-
e	0.35 BSC		
L	0.25	-	0.35
L1	0.275	-	0.475
L2	0.30	-	0.40
L3	0.325	-	0.525
Unit: mm			

10.6 QFN1.8x1.4-10L Mechanical Information

10.6.1 QFN1.8x1.4-10L Outline Dimensions

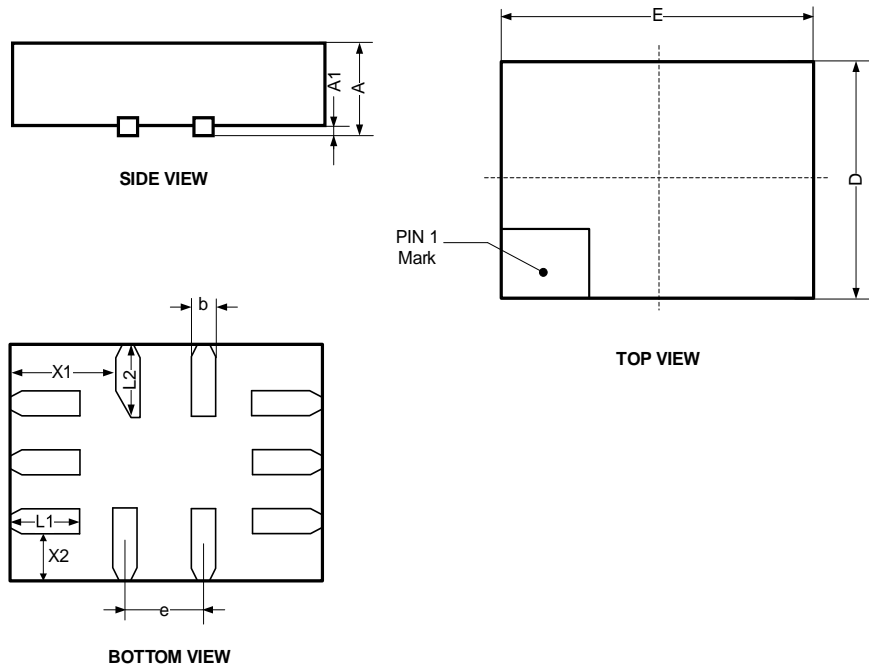

SYMBOL	Dimensions In Millimeters		
	Min.	Typ.	Max.
A	0.45	-	0.55
A1	-	0.03	-
D	1.30	-	1.50
E	1.70	-	1.90
b	0.15	-	0.25
L1	0.35	-	0.45
L2	0.45	-	0.55
e	0.40 BSC		
X1	0.55	-	0.65
X2	0.15	-	0.25
Unit: mm			

10.7 SOP14 Mechanical Information

10.7.1 SOP14 Outline Dimensions

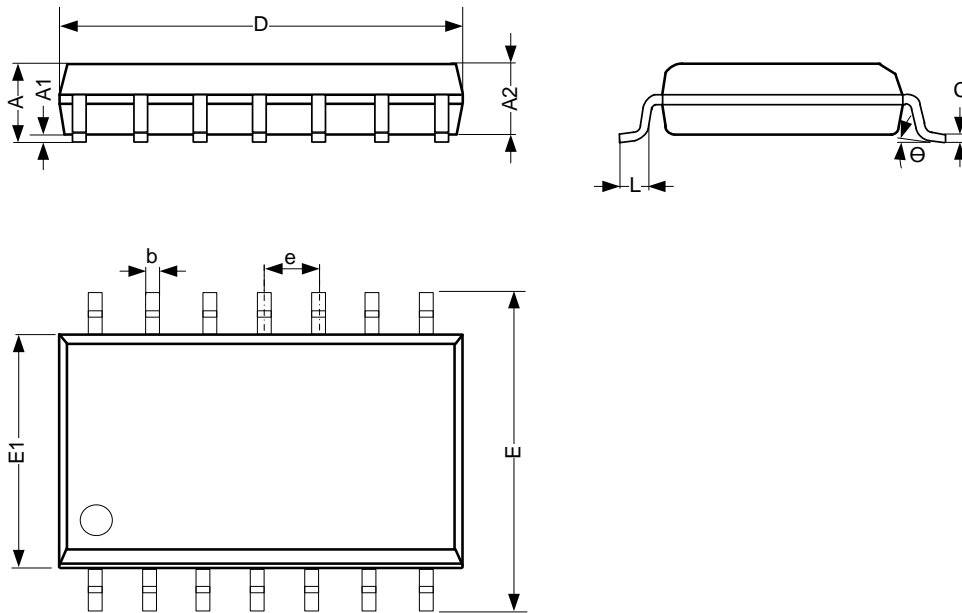

SYMBOL	Dimensions In Millimeters		
	Min.	Typ.	Max.
A	1.50	-	1.75
A1	0.05	-	0.25
A2	1.30	-	-
b	0.33	-	0.50
c	0.19	-	0.25
D	8.43	-	8.76
E	5.80	-	6.25
E1	3.75	-	4.00
e	1.27 BSC		
L	0.40	-	0.89
θ	0°	-	8°
Unit: mm			

10.8 TSSOP14 Mechanical Information

10.8.1 TSSOP14 Outline Dimensions

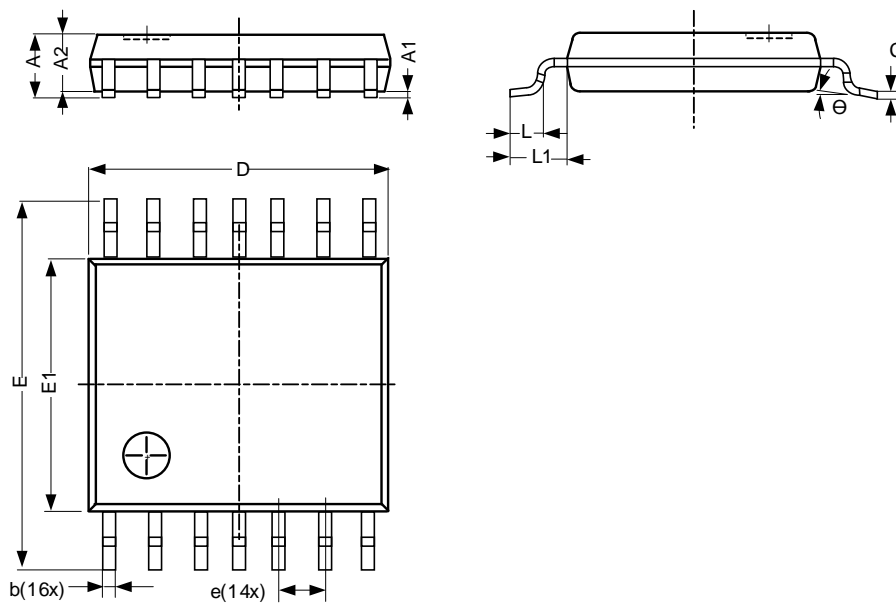

SYMBOL	Dimensions In Millimeters		
	Min.	Typ.	Max.
A	-	-	1.20
A1	0.05	-	0.15
A2	0.80	-	1.05
b	0.19	-	0.30
c	0.09	-	0.20
D	4.90	-	5.10
E	6.20	-	6.60
E1	4.30	-	4.50
e	0.65 BSC		
L	0.45	-	0.75
L1	-	1.00	-
θ	0°	-	8°
Unit: mm			

10.9 QFN3.5x3.5-14L Mechanical Information

10.9.1 QFN3.5x3.5-14L Outline Dimensions

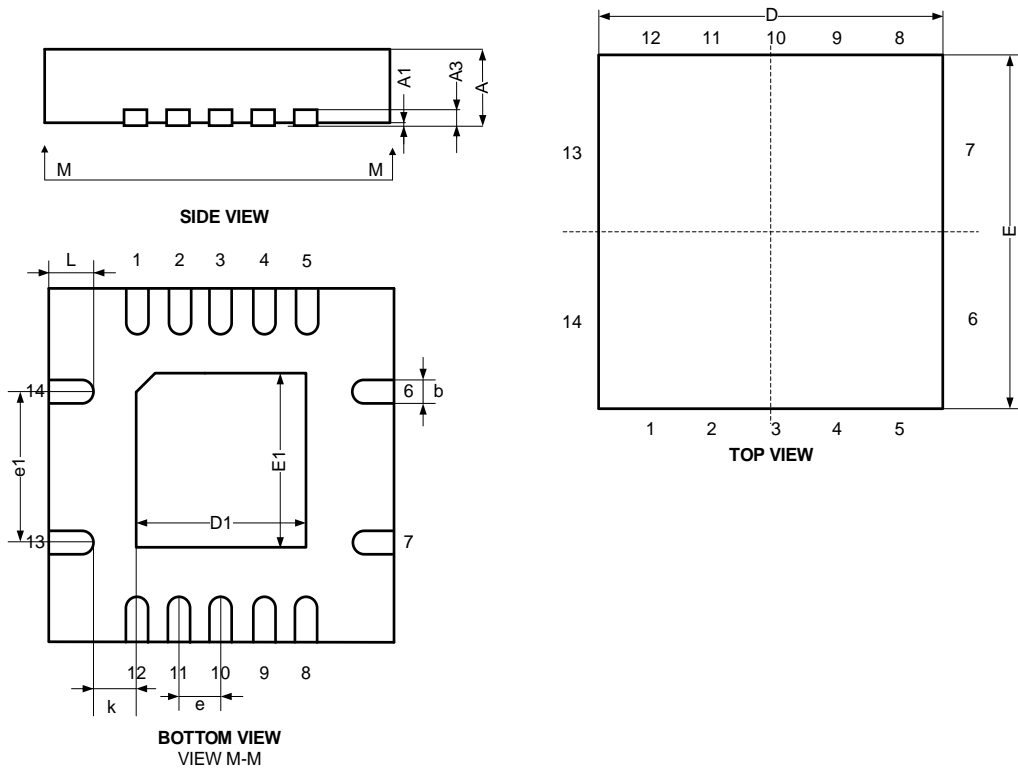

SYMBOL	Dimensions In Millimeters		
	Min.	Typ.	Max.
A	0.70	-	0.90
A1	0	-	0.05
A3	0.203 REF		
D	3.424	-	3.576
E	3.424	-	3.576
D1	1.95	-	2.15
E1	1.95	-	2.15
k	0.20	-	-
b	0.20	-	0.30
e	0.50 BSC		
e1	1.50 BSC		
L	0.324	-	0.476
Unit: mm			

10.10 TSSOP20 Mechanical Information

10.10.1 TSSOP20 Outline Dimensions

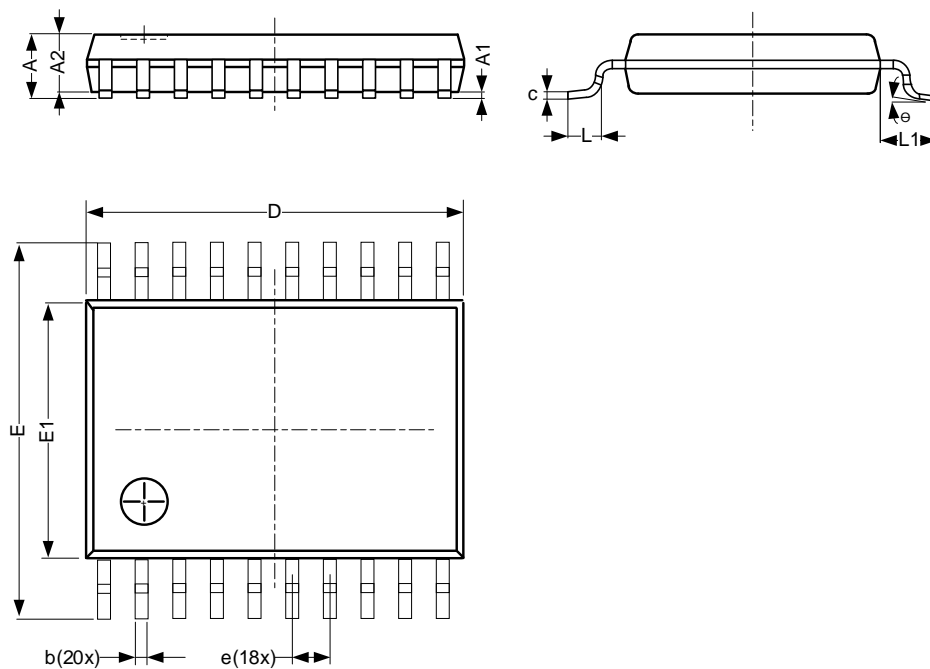

SYMBOL	Dimensions In Millimeters		
	Min.	Typ.	Max.
A	-	-	1.20
A1	0.05	-	0.15
A2	0.80	-	1.05
b	0.19	-	0.30
c	0.09	-	0.20
D	6.40	-	6.60
E	6.20	-	6.60
E1	4.30	-	4.50
e	0.65 BSC		
L	0.45	-	0.75
L1	-	1.00	-
θ	0°	-	8°
Unit: mm			

11 Notes and Revision History

11.1 Associated Product Family and Others

To view other products of the same type or IC products of other types, click the official website of JSCJ -- <https://www.jscj-elec.com> for more details.

11.2 Notes

Electrostatic Discharge Caution



This IC may be damaged by ESD. Relevant personnel shall comply with correct installation and use specifications to avoid ESD damage to the IC. If appropriate measures are not taken to prevent ESD damage, the hazards caused by ESD include but are not limited to degradation of integrated circuit performance or complete damage of integrated circuit. For some precision integrated circuits, a very small parameter change may cause the whole device to be inconsistent with its published specifications.

11.3 Revision History

January, 2026: rev -1.1A, Change TSSOP8 marking information.

April, 2026: rev -1.2A, Update package from TSSOP8 to TSSOP8(3x3).

DISCLAIMER

IMPORTANT NOTICE, PLEASE READ CAREFULLY

The information in this data sheet is intended to describe the operation and characteristics of our products. JSCJ has the right to make any modification, enhancement, improvement, correction or other changes to any content in this data sheet, including but not limited to specification parameters, circuit design and application information, without prior notice.

Any person who purchases or uses JSCJ products for design shall: 1. Select products suitable for circuit application and design; 2. Design, verify and test the rationality of circuit design; 3. Procedures to ensure that the design complies with relevant laws and regulations and the requirements of such laws and regulations. JSCJ makes no warranty or representation as to the accuracy or completeness of the information contained in this data sheet and assumes no responsibility for the application or use of any of the products described in this data sheet.

Without the written consent of JSCJ, this product shall not be used in occasions requiring high quality or high reliability, including but not limited to the following occasions: medical equipment, military facilities and aerospace. JSCJ shall not be responsible for casualties or property losses caused by abnormal use or application of this product.

Official Website: www.jscj-elec.com

Copyright © JIANGSU CHANGJING ELECTRONICS TECHNOLOGY CO., LTD