



TO-252-2L Plastic-Encapsulate MOSFETS

CJU02N60M1 N-Channel Power MOSFET

$V_{(BR)DSS}$	$R_{DS(on)MAX}$	I_D
600V	2.7Ω@10V	2A

General Description

The high voltage MOSFET uses an advanced termination scheme to provide enhanced voltage-blocking capability without degrading performance over time. In addition, this advanced MOSFET is designed to withstand high energy in avalanche and commutation modes. The new energy efficient design also offers a drain-to-source diode with a fast recovery time. Designed for high voltage, high speed switching applications in power suppliers, converters and PWM motor controls, these devices are particularly well suited for bridge circuits where diode speed and commutating safe operating areas are critical and offer additional and safety margin against unexpected voltage transients.

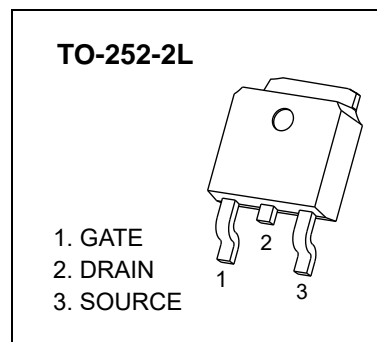

FEATURES

- Robust High Voltage Termination
- Avalanche Energy Specified
- Source-to-Drain Diode Recovery Time Comparable to a Discrete Fast Recovery Diode
- Diode is Characterized for Use in Bridge Circuits
- I_{DSS} and $V_{DS(on)}$ Specified at Elevated Temperature

MARKING

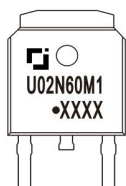

U02N60M1= Device code
 Solid dot = Green molding compound device,
 if none, the normal device
 XXXX=Code

EQUIVALENT CIRCUIT

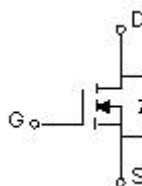

Maximum ratings ($T_a=25^\circ\text{C}$ unless otherwise noted)

Parameter	Symbol	Value	Unit
Drain-Source Voltage	V_{DS}	600	V
Gate-Source Voltage	V_{GS}	±30	
Continuous Drain Current	$I_D^{(1)}$	2	A
Pulsed Drain Current	$I_{DM}^{(2)}$	8	
Single Pulsed Avalanche Energy	$E_{AS}^{(3)}$	88	mJ
Power Dissipation	$P_D^{(1)}$	31	W
Thermal Resistance from Junction to Ambient	$R_{\theta JA}^{(6)}$	100	$^\circ\text{C}/\text{W}$
Thermal Resistance from Junction to Case	$R_{\theta JC}^{(1)}$	4	$^\circ\text{C}/\text{W}$
Operating Junction and Storage Temperature Range	T_J, T_{STG}	-55 ~+150	$^\circ\text{C}$

MOSFET ELECTRICAL CHARACTERISTICS

$T_J = 25^\circ\text{C}$ unless otherwise specified

Parameter	Symbol	Test Condition	Min	Typ	Max	Unit
Off characteristics						
Drain-source breakdown voltage	$V_{(BR)DSS}$	$V_{GS}=0V, I_D=250\mu A$	600			V
Zero gate voltage drain current	I_{DSS}	$V_{DS}=600V, V_{GS}=0V$			1.0	μA
Gate-body leakage current	I_{GSS}	$V_{DS}=0V, V_{GS}=\pm 30V$			± 100	nA
On characteristics ^④						
Gate-threshold voltage	$V_{GS(th)}$	$V_{DS}=V_{GS}, I_D=250\mu A$	2.0	3.4	4.0	V
Static drain-source on-state resistance	$R_{DS(on)}$	$V_{GS}=10V, I_D=1A$		2.7	3.7	Ω
Dynamic characteristics ^⑤						
Input capacitance	C_{iss}	$V_{DS}=25V, V_{GS}=0V,$ $f=1MHz$		322		pF
Output capacitance	C_{oss}			38		
Reverse transfer capacitance	C_{rss}			7		
Gate resistance	R_g	$f=1MHz$		5.7		Ω
Switching characteristics ^⑤						
Total gate charge	Q_g	$V_{GS}=10V,$ $V_{DS}=25V, I_D=2A$		1.6		nC
Gate-source charge	Q_{gs}			2.1		
Gate-drain charge	Q_{gd}			6.2		
Turn-on delay time	$t_{d(on)}$	$V_{DD}=25V, V_{GS}=10V,$ $R_G=18\Omega, I_D=2A$		1.8		nS
Turn-on rise time	t_r			3.2		
Turn-off delay time	$t_{d(off)}$			7.4		
Turn-off fall time	t_f			7.6		
Drain-Source Diode Characteristics						
Drain-source diode forward voltage	V_{SD} ^④	$V_{GS}=0V, I_S=2A$			1.4	V
Continuous drain-source diode forward current	I_S ^①				2.0	A
Pulsed drain-source diode forward current	I_{SM} ^②				8.0	A
Reverse recovery time	t_{rr}	$dI_F/dt = 100A/\mu s,$ $I_S = 2A, V_{DD} = 400V$		192		ns
Reverse recovery charge	Q_{rr}			1027		nC

Notes:

- $T_C=25^\circ\text{C}$ Limited only by maximum temperature allowed.
- $P_W \leq 10\mu s$, Duty cycle $\leq 1\%$.
- EAS condition: $V_{DD}=150V, V_{GS}=10V, L=10mH, R_g=25\Omega$ Starting $T_J = 25^\circ\text{C}$.
- Pulse Test : Pulse Width $\leq 300\mu s$, duty cycle $\leq 2\%$.
- Guaranteed by design, not subject to production.
- The value of $R_{\theta JA}$ is measured with the device in a still air environment with $T_A=25^\circ\text{C}$.

Typical Characteristics

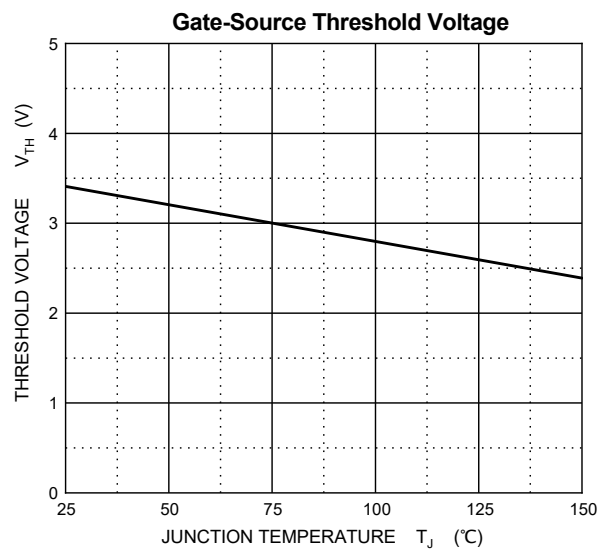
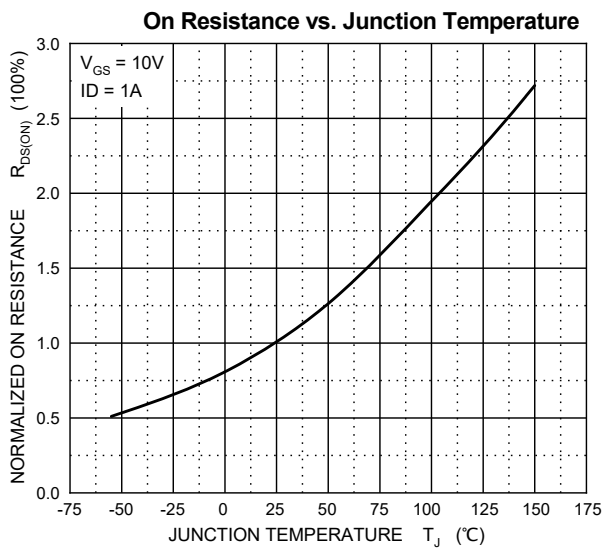
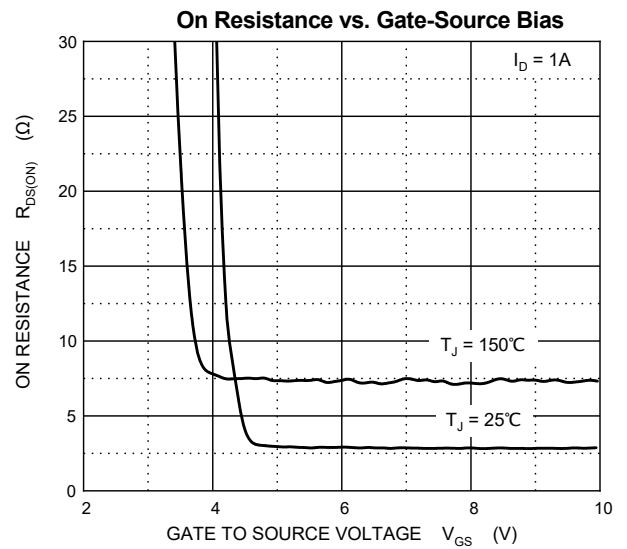
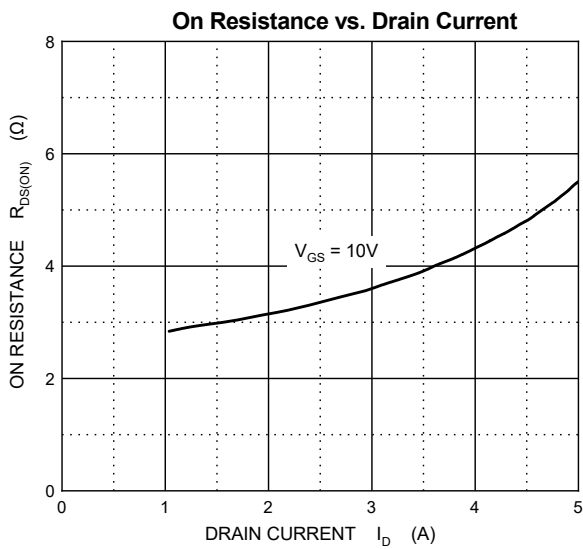
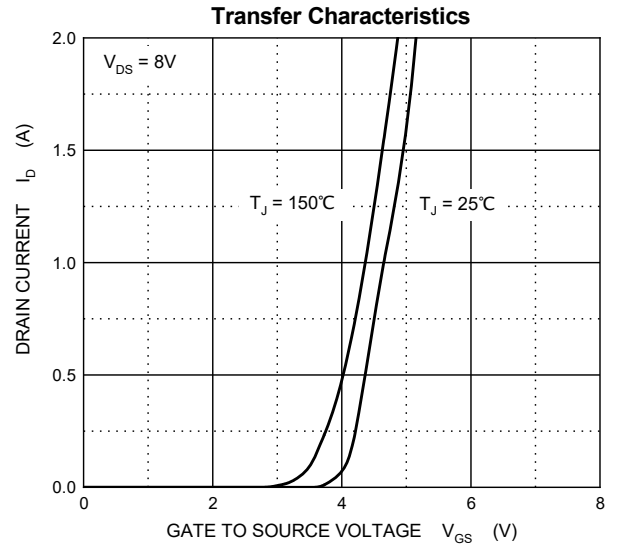
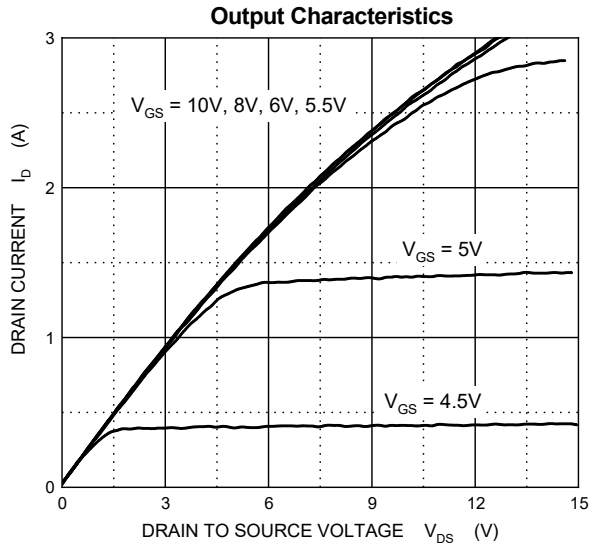

Typical Characteristics

Typical Capacitances

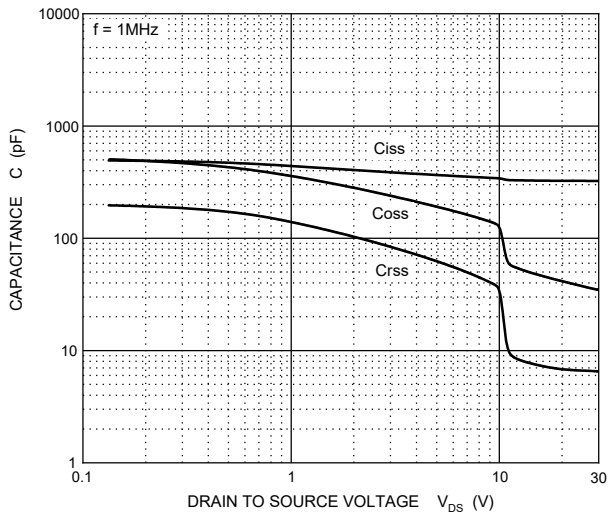

Gate Charge

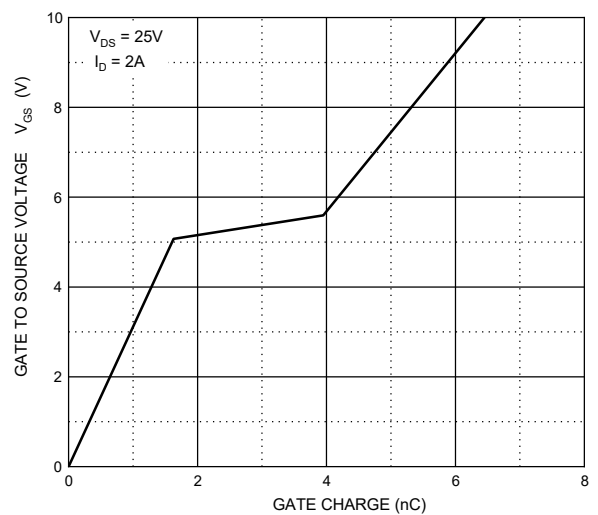

Source-Drain Diode Forward Characteristics

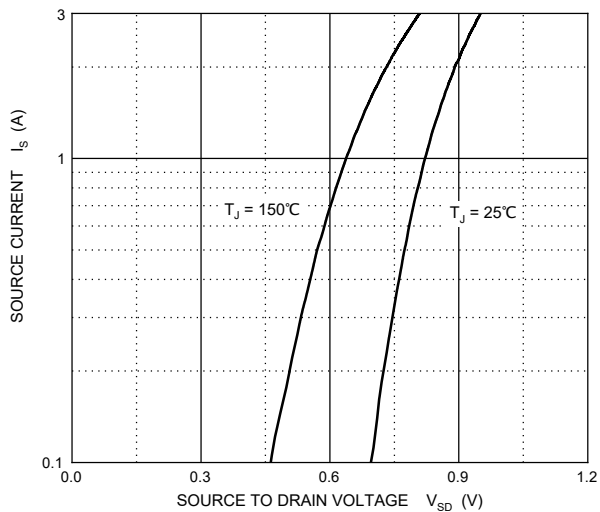

Maximum Safe Operating Area

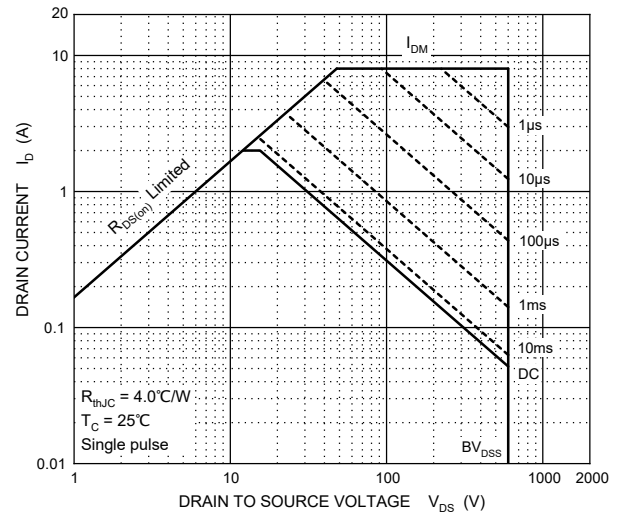

Transient Thermal Impedance, Junction-Case

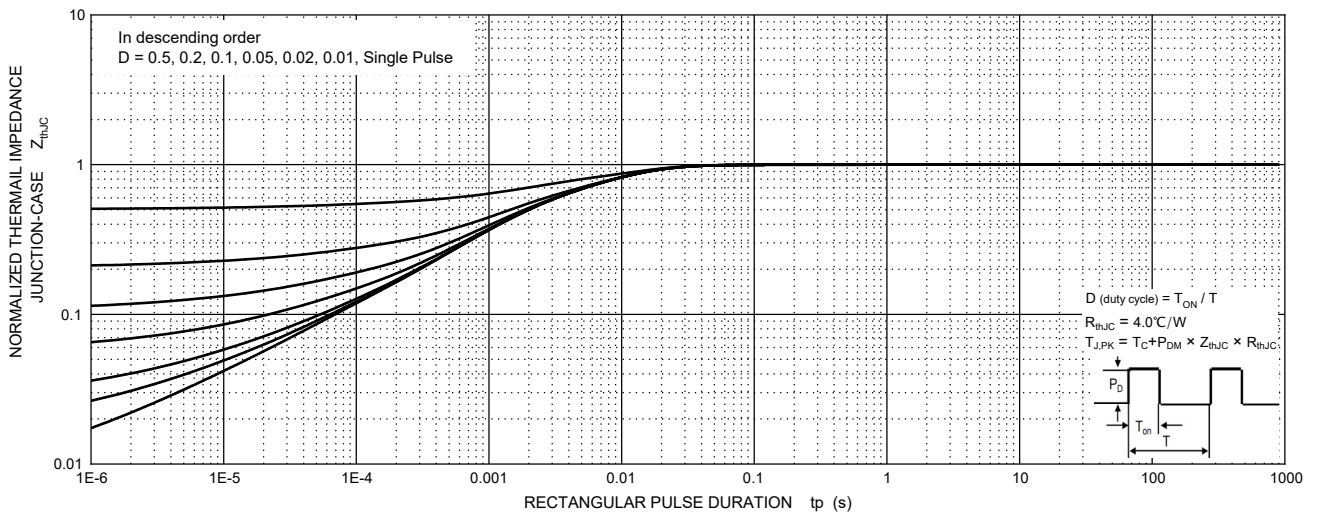

TO-252(4R)-2L Package Outline Dimensions

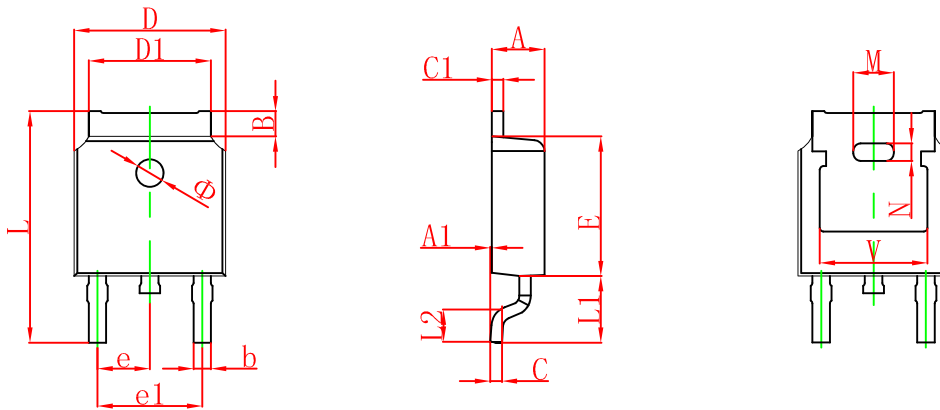

Symbol	Dimensions In Millimeters		Dimensions In Inches	
	Min.	Max.	Min.	Max.
A	2.200	2.380	0.087	0.094
A1	0.000	0.100	0.000	0.004
B	0.800	1.400	0.031	0.055
b	0.710	0.810	0.028	0.032
c	0.460	0.560	0.018	0.022
c1	0.460	0.560	0.018	0.022
D	6.500	6.700	0.256	0.264
D1	5.130	5.460	0.202	0.215
E	6.000	6.200	0.236	0.244
e	2.286 TYP.		0.090 TYP.	
e1	4.327	4.727	0.170	0.186
M	1.778REF.		0.070REF.	
N	0.762REF.		0.018REF.	
L	9.800	10.400	0.386	0.409
L1	2.9REF.		0.114REF.	
L2	1.400	1.700	0.055	0.067
V	4.830 REF.		0.190 REF.	
Φ	1.100	1.300	0.043	0.051

TO-252(4R)-2L Suggested Pad Layout

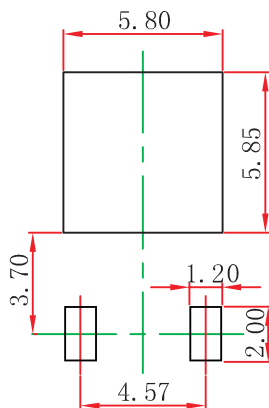

Note:

1. Controlling dimension: in millimeters.
2. General tolerance: $\pm 0.05\text{mm}$.
3. The pad layout is for reference purposes only.

NOTICE

JSCJ reserves the right to make modifications, enhancements, improvements, corrections or other changes without further notice to any product herein. JSCJ does not assume any liability arising out of the application or use of any product described herein.

TO-252-2L Tape and Reel

TO-252-2L Embossed Carrier Tape



Packaging Description:

TO-252-2L parts are shipped in tape. The carrier tape is made from a dissipative (carbon filled) polycarbonate resin. The cover tape is a multilayer film (Hear Activated Adhesive in nature) primarily composed of polyester film, adhesive layer, sealant, and anti-static sprayed agent. These reeled parts in standard option are shipped with 2500 units per 13" or 33.0 cm diameter reel. The reels are clear in color and is made of polystyrene plastic (anti-static coated).

Dimensions are in millimeter										
Pkg type	A	B	C	d	E	F	P0	P	P1	W
TO-252	6.90	10.50	2.70	Φ1.55	1.75	7.50	4.00	8.00	2.00	16.00

TO-252-2L Tape Leader and Trailer

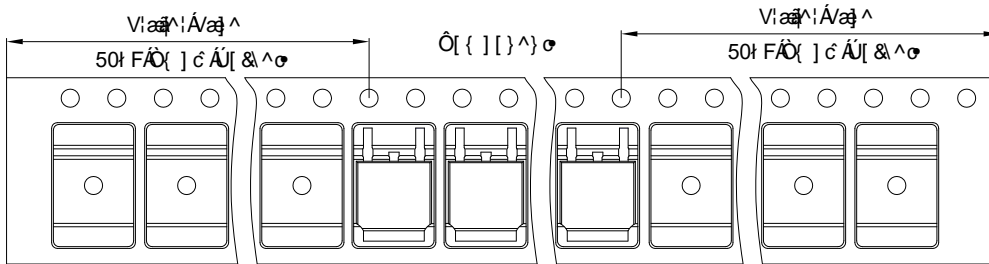

TO-252-2L Reel



Dimensions are in millimeter						
Reel	D	D1	D2	W1	W2	I
13" Dia	330.00	100.00	Φ21.00	16.40	21.40	Φ13.00

Reel	Reel Size	Box	Box Size(mm)	Carton	Carton Size(mm)
2500 pcs	13 inch	5000 pcs	360×360×65	25000 pcs	378×358×382