

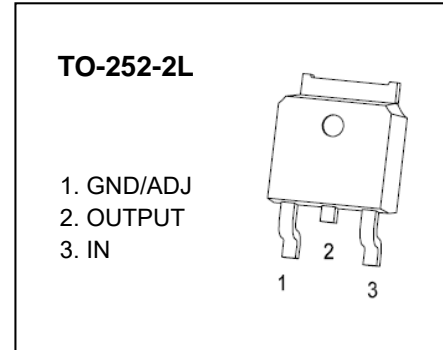

## CJU1117B-XXX

### FEATURES

- Low Dropout Voltage: 1.3V at 1A Output Current
- Trimmed Current Limit
- On-Chip Thermal Shutdown
- Three-Terminal Adjustable or Fixed 1.8V, 2.5V, 3.3V, 5V
- Operation Junction Temperature: -40 °C to 125°C



### GENERAL DESCRIPTION

The CJU1117B-XXX is a series of low dropout three-terminal regulators with a dropout of 1.3V at 1A output current.

The CJU1117B-XXX series provides current limiting and thermal shutdown. Its circuit includes a trimmed bandage. reference to assure output voltage accuracy to be within 1.5%. Current limit is trimmed to ensure specified. output current and controlled short-circuit current. On-chip thermal shutdown provides protection against any combination of overload and ambient temperature that would create excessive junction temperature.

The CJU1117B-XXX has an adjustable version, that can provide the output voltage from 1.25V to 12V with only 2 external resistors.

### APPLICATIONS

- PC Motherboard
- LCD Monitor
- Graphic Card
- DVD-Video Player
- NIC/Switch
- Telecom Modem
- ADSL Modem
- Printer and other peripheral Equipment

---

## MAXIMUM RATINGS

---

### ORDERING INFORMATION

Package	Operating Junction Temperature Range	Part NO.
TO-252-2L	-40 to 125°C	CJU1117B-ADJ
		CJU1117B-1.8
		CJU1117B-2.5
		CJU1117B-3.3
		CJU1117B-5.0

### ABSOLUTE MAXIMUM RATINGS (T<sub>a</sub>=25°C unless otherwise noted)

Parameter	Symbol	Value	Unit
Input Voltage	V <sub>i</sub>	20	V
Thermal Resistance from Junction to Ambient	R <sub>θJA</sub>	80	°C/W
Operating Ambient Temperature	T <sub>A</sub>	-40~+85	°C
Operating Junction Temperature	T <sub>j</sub>	-40~+125	°C
Storage Temperature	T <sub>stg</sub>	-40~+150	°C
Lead Temperature (Soldering, 10sec.)	T <sub>L</sub>	260°C,10s	
ESD Voltage (Machine Model)	V <sub>ESD</sub>	250	V

Note: Stresses greater than those listed under "Absolute Maximum Ratings" may cause permanent damage to the device. These are stress ratings only, and functional of the device at these or any other conditions beyond those indicated under "Recommended Operating Conditions" is not implied. Exposure to "Absolute Maximum Ratings" for extended periods may affect device reliability.

### RECOMMENDED OPERATING CONDITIONS

Parameter	Symbol	Value	Unit
Input Voltage	V <sub>i</sub>	15	V
Operating Junction Temperature	T <sub>j</sub>	-40~+125	°C

## ELECTRICAL CHARACTERISTICS

$V_{IN} \leq 10V$ ,  $T_J = 25^\circ C$  unless otherwise specified.

Parameter	Symbol	Part No.	Test Conditions	Min	Typ	Max	Unit
Reference Voltage	$V_{IROC}$	CJU1117B-ADJ	$I_{OUT} = 10mA$ , $V_{IN} = 3.23V$	1.231	1.250	1.269	V
			$10mA \leq I_{OUT} \leq 1A$ , $2.75V \leq V_{IN} - V_{OUT} \leq 13.25V$	1.225	1.250	1.275	
Output Voltage	$V_O$	CJU1117B-1.8	$I_{OUT} = 10mA$ , $V_{IN} = 3.8V$	1.773	1.8	1.827	V
			$10mA \leq I_{OUT} \leq 1A$ , $3.3V \leq V_{IN} \leq 12V$	1.764	1.8	1.836	
		CJU1117B-2.5	$I_{OUT} = 10mA$ , $V_{IN} = 4.5V$	2.463	2.5	2.538	V
			$10mA \leq I_{OUT} \leq 1A$ , $4V \leq V_{IN} \leq 12V$	2.450	2.5	2.550	
		CJU1117B-3.3	$I_{OUT} = 10mA$ , $V_{IN} = 5.3V$	3.251	3.3	3.350	V
			$10mA \leq I_{OUT} \leq 1A$ , $4.8V \leq V_{IN} \leq 12V$	3.234	3.3	3.366	
		CJU1117B-5.0	$I_{OUT} = 10mA$ , $V_{IN} = 7.0V$	4.925	5.0	5.075	V
			$10mA \leq I_{OUT} \leq 1A$ , $6.5V \leq V_{IN} \leq 12V$	4.9	5.0	5.1	
Line Regulation	LNR	CJU1117B-ADJ	$I_{OUT} = 10mA$ , $1.5V \leq V_{IN} - V_{OUT} \leq 12V$			0.2	mV
		CJU1117B-1.8	$I_{OUT} = 10mA$ , $1.5V \leq V_{IN} - V_{OUT} \leq 10.2V$			7	
		CJU1117B-2.5	$I_{OUT} = 10mA$ , $1.5V \leq V_{IN} - V_{OUT} \leq 9.5V$			7	
		CJU1117B-3.3	$I_{OUT} = 10mA$ , $1.5V \leq V_{IN} - V_{OUT} \leq 8.7V$			7	
		CJU1117B-5.0	$I_{OUT} = 10mA$ , $1.5V \leq V_{IN} - V_{OUT} \leq 7V$			10	
Load Regulation	LDR	CJU1117B-ADJ	$V_{IN} - V_{OUT} = 1.5V$ , $10mA \leq I_{OUT} \leq 1A$			0.4	mV
		CJU1117B-1.8				7.2	
		CJU1117B-2.5				10	
		CJU1117B-3.3				13.2	
		CJU1117B-5.0				20	
Dropout Voltage	$V_D$		$\Delta V_{REF} = 1\%$ , $I_{OUT} = 1.0A$		1.3	1.4	V
Adjust Pin Current	$I_{Adj}$	CJU1117B-ADJ	$V_{IN} = 5V$ , $10mA \leq I_{OUT} \leq 0.8A$		55	120	$\mu A$
Minimum Load Current	$I_L$		$2.75V \leq V_{IN} - V_{OUT} \leq 12V$ (ADJ only)		2	10	$\mu A$
Quiescent Current	$I_q$		$V_{IN} = 12V$ (ADJ except)		2	5	mA
Ripple Rejection	PSRR		$f = 10kHz$ , $C_{OUT} = 22\mu F$ Tantalum, $V_{IN} - V_{OUT} = 3V$ , $I_{OUT} = 1A$	60	70		dB
Temperature Stability					0.5		%
Long-Term Stability			$T_A = 125^\circ C$ , 1000hrs		0.3		%
RMS Output Noise (% of VOUT)			$T_A = 25^\circ C$ , $10Hz \leq f \leq 10kHz$		0.003		%
Thermal Shutdown Hysteresis					25		$^\circ C$

\* With package soldering to copper area over backside ground plane or internal power plane  $R_{\theta JA}$  can vary from  $46^\circ C/W$  to  $>90^\circ C/W$  depending on mounting technique and the size of the copper area

# FUNCTIONAL BLOCK and TYPICAL APPLICATION

## FUNCTIONAL BLOCK DIAGRAM

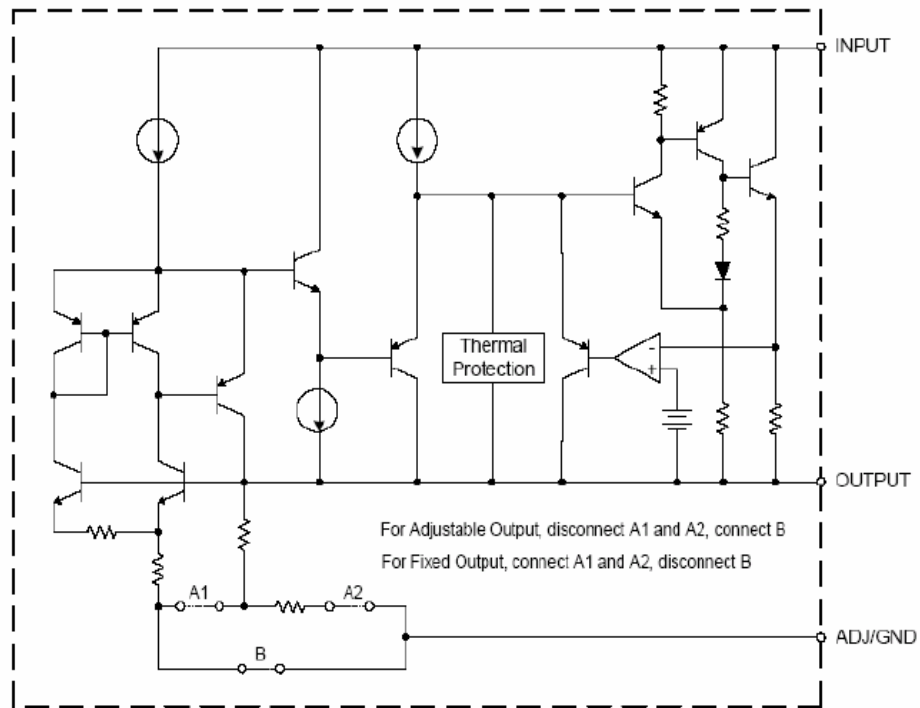

## TYPICAL APPLICATION CIRCUIT

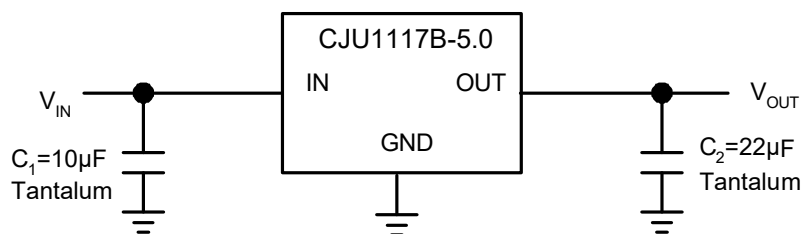
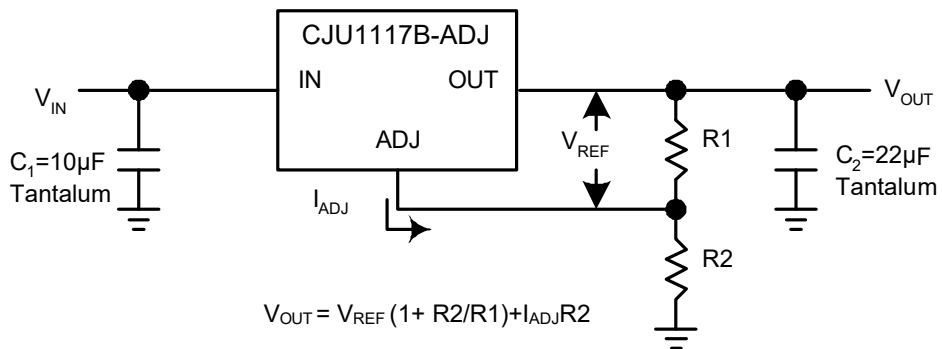

# TYPICAL PERFORMANCE CHARACTERISTICS

**Dropout Voltage vs. Output Current**

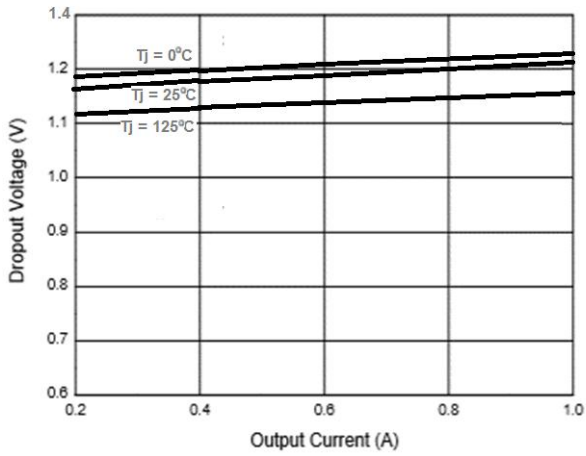

**Dropout Voltage vs. Junction Temperature**

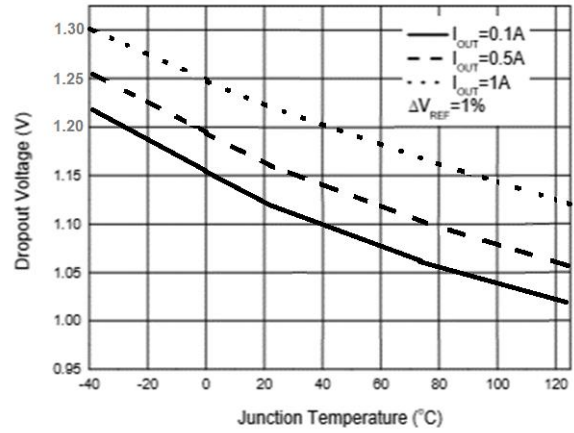

**Load Regulation vs. Junction Temperature**

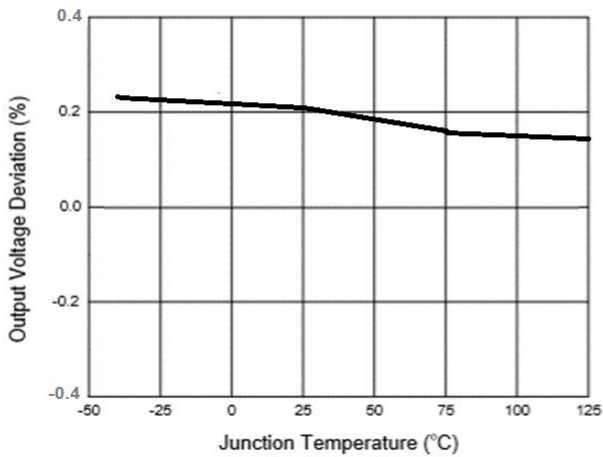

**Reference Voltage vs. Junction Temperature**

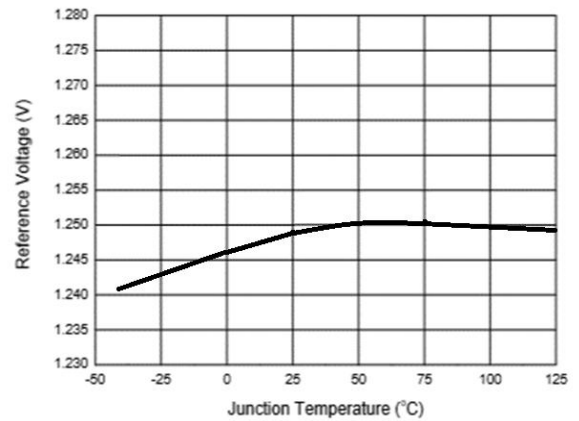

**Output Voltage vs. Junction Temperature**

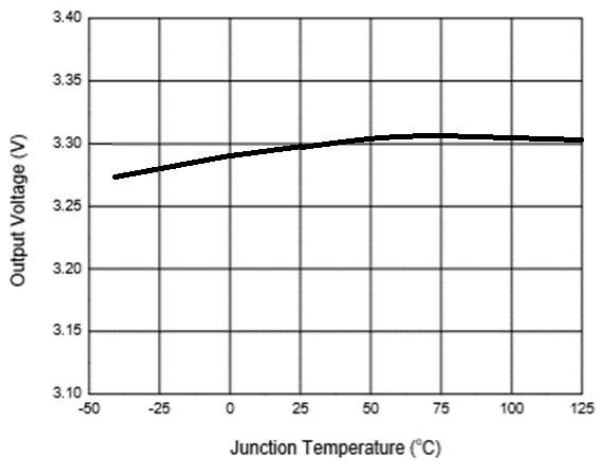

**Minimum Load Current vs. Junction Temperature**

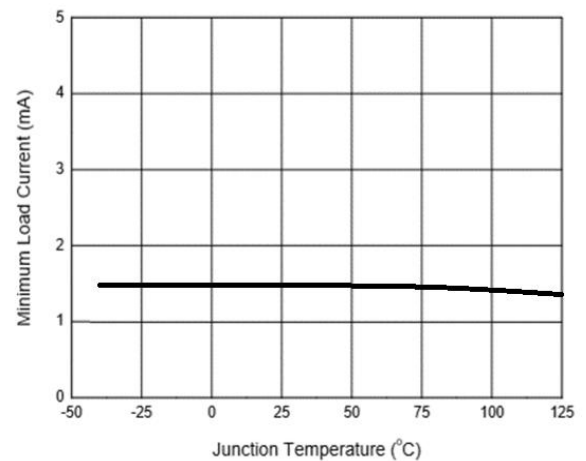

# TYPICAL PERFORMANCE CHARACTERISTICS

### Adjust Pin Current vs. Junction Temperature

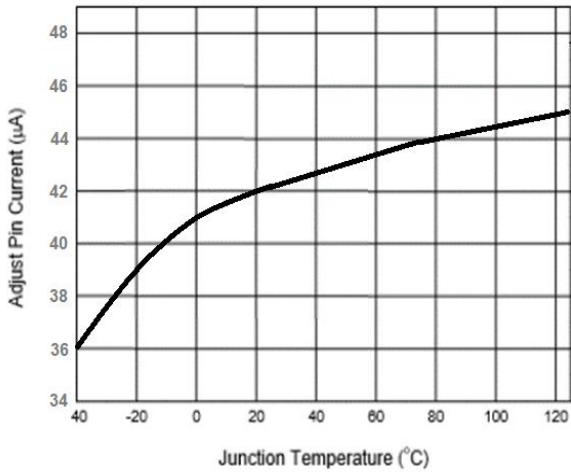

### Short-circuit Current vs. Junction Temperature

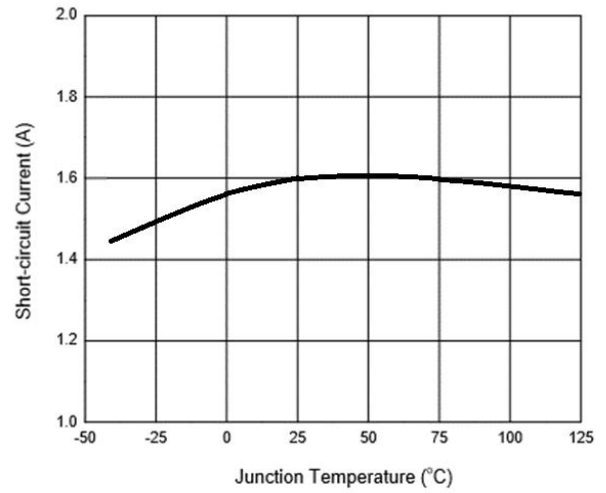

### Ripple Rejection vs. Frequency

$V_{in}=V_{out}+2.5\text{ V}$ ,  $I_{out}=100\text{ mA}$ ,  $C_{out}=10\mu\text{F}$

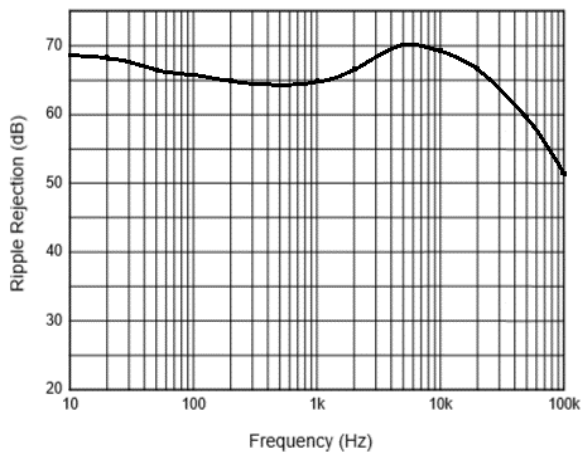

## TO-252(4R)-2L Package Outline Dimensions

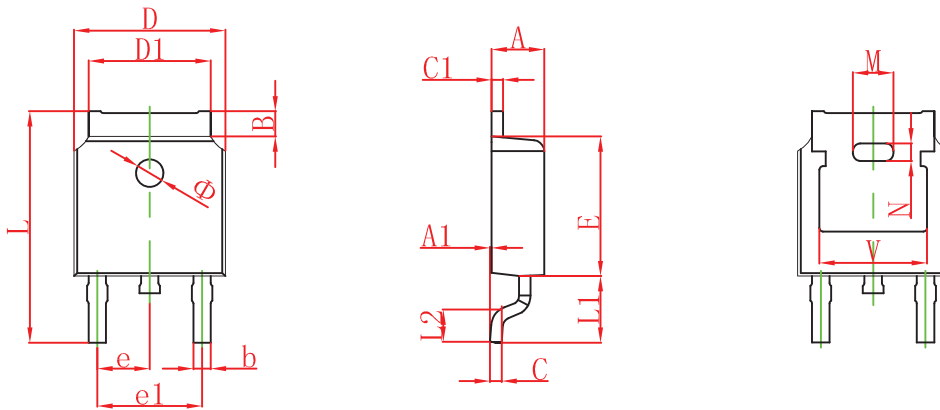

Symbol	Dimensions In Millimeters		Dimensions In Inches	
	Min.	Max.	Min.	Max.
A	2.200	2.380	0.087	0.094
A1	0.000	0.100	0.000	0.004
B	0.800	1.400	0.031	0.055
b	0.710	0.810	0.028	0.032
c	0.460	0.560	0.018	0.022
c1	0.460	0.560	0.018	0.022
D	6.500	6.700	0.256	0.264
D1	5.130	5.460	0.202	0.215
E	6.000	6.200	0.236	0.244
e	2.286 TYP.		0.090 TYP.	
e1	4.327	4.727	0.170	0.186
M	1.778REF.		0.070REF.	
N	0.762REF.		0.018REF.	
L	9.800	10.400	0.386	0.409
L1	2.9REF.		0.114REF.	
L2	1.400	1.700	0.055	0.067
V	4.830 REF.		0.190 REF.	
Φ	1.100	1.300	0.043	0.051

## TO-252(4R)-2L Suggested Pad Layout

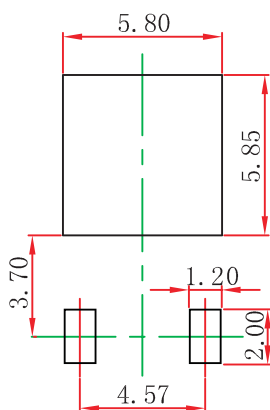

### Note:

1. Controlling dimension: in millimeters.
2. General tolerance:  $\pm 0.05\text{mm}$ .
3. The pad layout is for reference purposes only.

### NOTICE

JSCJ reserves the right to make modifications, enhancements, improvements, corrections or other changes without further notice to any product herein. JSCJ does not assume any liability arising out of the application or use of any product described herein.

# To-252(4R)-2L Tape and Reel

## TO-252 Embossed Carrier Tape

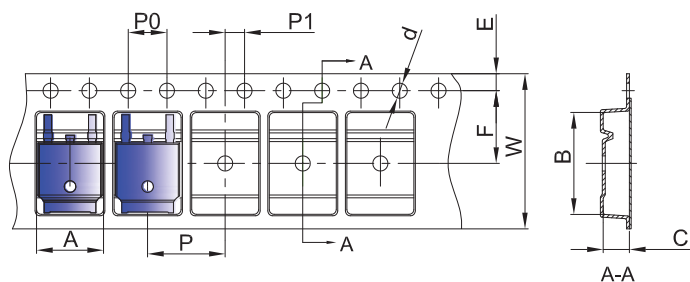

### Packaging Description:

TO-252 parts are shipped in tape. The carrier tape is made from a dissipative (carbon filled) polycarbonate resin. The cover tape is a multilayer film (Heat Activated Adhesive in nature) primarily composed of polyester film, adhesive layer, sealant, and anti-static sprayed agent. These reeled parts in standard option are shipped with 25,00 units per 13" or 33.0 cm diameter reel. The reels are clear in color and is made of polystyrene plastic (anti-static coated).

Dimensions are in millimeter										
Pkg type	A	B	C	d	E	F	P0	P	P1	W
TO-252	6.90	10.50	2.70	Ø1.55	1.75	7.50	4.00	8.00	2.00	16.00

## TO-252 Tape Leader and Trailer

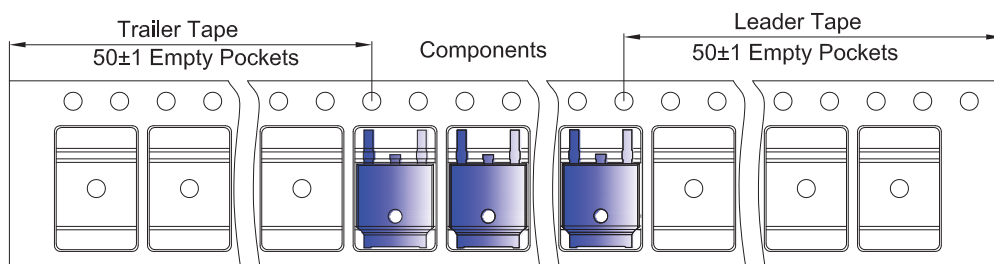

## TO-252 Reel

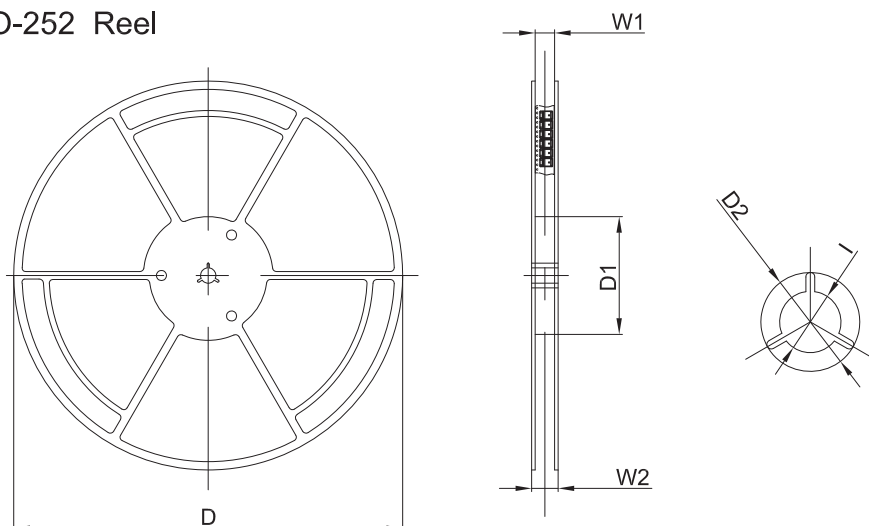

Dimensions are in millimeter						
Reel Option	D	D1	D2	W1	W2	I
13" Dia	330.00	100.00	Ø21.00	16.40	21.00	Ø13.00

REEL	Reel Size	Box	Box Size(mm)	Carton	Carton Size(mm)	G.W.(kg)
2,500 pcs	13inch	2,500 pcs	340×336×29	25,000 pcs	353×346×365	