

TO-252-2L Plastic-Encapsulate MOSFET

CJU5R0N03MJ N-Channel Power MOSFET

Key Performance Parameters

V_{BR(DSS)}	R_{DS(on)TYP}	I_D
30V	4.0mΩ@10V	80A
	6.6mΩ@4.5V	

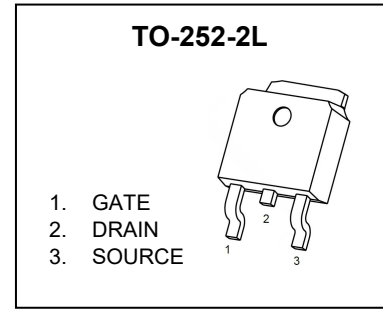

DESCRIPTION

The N-Channel enhancement mode power field effect transistors is using trench technology. This advanced technology has been especially tailored to minimize on-state resistance, provide superior switching performance, and withstand high energy pulse in the avalanche and commutation mode. These devices are well suited for high efficiency fast switching applications.

FEATURES

- 100% Avalanche tested
- Low drain-source on-resistance
- Low gate charge
- High current capability

APPLICATIONS

- DC/DC
- Switching application

MARKING

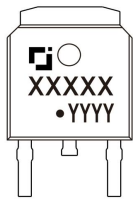

XXXXX = 5R0N03MJ
 Solid dot = Pin1 indicator.
 YY = Code.

EQUIVALENT CIRCUIT

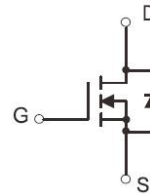

ABSOLUTE MAXIMUM RATINGS (T_J=25°C unless otherwise specified)

Parameter		Symbol	Value	Unit
Drain-Source Voltage		V _{DS}	30	V
Gate-Source Voltage		V _{GS}	±20	V
Continuous Drain Current	T _C =25°C	I _D	80	A
	T _C =100°C		50	
Pulsed Drain Current		I _{DM} ^{①②}	320	A
Continuous Drain Current	T _A =25°C	I _D	13.9	A
	T _A =75°C		10.7	
Avalanche Current		I _{AS} ^③	16	A
Single Pulsed Avalanche Energy		E _{AS} ^③	64	mJ
Power Dissipation		P _D ^①	56.8	W
Operating Junction and Storage Temperature Range		T _J , T _{stg}	-55~+150	°C

Thermal Characteristics

Parameter	Symbol	Value		Unit
		Typ	Max	
Thermal Resistance from Junction to Case	R _{θJC}	1.45	2.2	°C/W
Thermal Resistance from Junction to Ambient	R _{θJA} ^⑥	48	72	°C/W

Typical Characteristics

ELECTRICAL CHARACTERISTICS (T_J=25°C unless otherwise specified)

Static Characteristics

Parameter	Symbol	Test Condition	Value			Unit	
			Min	Typ	Max		
Drain-source breakdown voltage	V _{(BR)DSS}	V _{GS} =0V, I _D =250μA	30	-	-	V	
Zero gate voltage drain current	I _{DSS}	V _{DS} =30V, V _{GS} =0V	T _J =25°C	-	-	1.0	μA
			T _J =125°C	-	-	100	
Gate-body leakage current	I _{GSS}	V _{GS} =±20V, V _{DS} =0V	-	-	±100	nA	
Gate-threshold voltage	V _{GS(th)}	V _{DS} =V _{GS} , I _D =250μA	1.0	1.6	2.0	V	
Static drain-source on-state resistance	R _{DS(on)} ^④	V _{GS} =10V, I _D =15A	T _J =25°C	-	4.0	5.0	mΩ
			T _J =125°C	-	6.4	8.0	
		V _{GS} =4.5V, I _D =10A	-	6.6	8.3		
Forward transconductance	g _{FS}	V _{DS} =5V, I _D =15A	-	46	-	S	

Dynamic Characteristics^⑤

Input capacitance	C _{iss}	V _{GS} =0V, V _{DS} =15V, f=1MHz	-	1547	-	pF
Output capacitance	C _{oss}		-	199	-	
Reverse transfer capacitance	C _{rss}		-	189	-	
Gate resistance	R _g	f=1MHz	-	7	-	Ω
Total gate charge	Q _g	V _{GS} =4.5V, V _{DS} =15V, I _D =15A	-	17.4	-	nC
Total gate charge	Q _g	V _{GS} =10V, V _{DS} =15V, I _D =15A	-	36.1	-	
Gate charge at threshold	Q _{G(th)}		-	2.5	-	
Gate-source charge	Q _{gs}		-	4.3	-	
Gate-drain charge	Q _{gd}		-	8.6	-	
Turn-on delay time	t _{d(on)}	V _{DD} =15V, V _{GS} =10V, I _D =15A, R _g =3Ω	-	3.6	-	ns
Turn-on rise time	t _r		-	7.0	-	
Turn-off delay time	t _{d(off)}		-	61.8	-	
Turn-off fall time	t _f		-	26.7	-	

Reverse Diode Characteristics

Drain-source diode forward voltage	V _{SD} ^④	V _{GS} =0V, I _S =15A	-	-	1.2	V
Continuous drain-source diode forward current	I _S ^①		-	-	80	A
Pulsed drain-source diode forward current	I _{SM} ^{①②}		-	-	320	A
Reverse recovery time	t _{rr}	V _{DD} =15V, I _S =15A,	-	10.5	-	ns
Reverse recovery charge	Q _{rr}	di/dt=100A/μs	-	5.3	-	nC

Notes:

- ①. T_C=25°C Limited only by maximum temperature allowed.
- ②. P_W≤10μs, Duty cycle ≤1%.
- ③. EAS condition: V_{DD}=15V, V_{GS}=10V, L=0.5mH, R_g=25Ω Starting T_J=25°C.
- ④. Pulse Test : Pulse Width ≤380μs, duty cycle ≤2%.
- ⑤. Guaranteed by design, not subject to production.
- ⑥. Device mounted on 1 in² FR-4 board with 2oz. double-sided Copper, in a still air environment with T_A=25°C.

Typical Characteristics

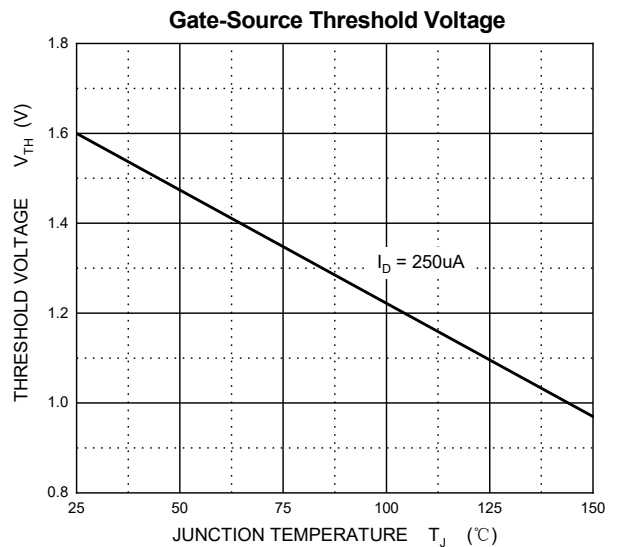
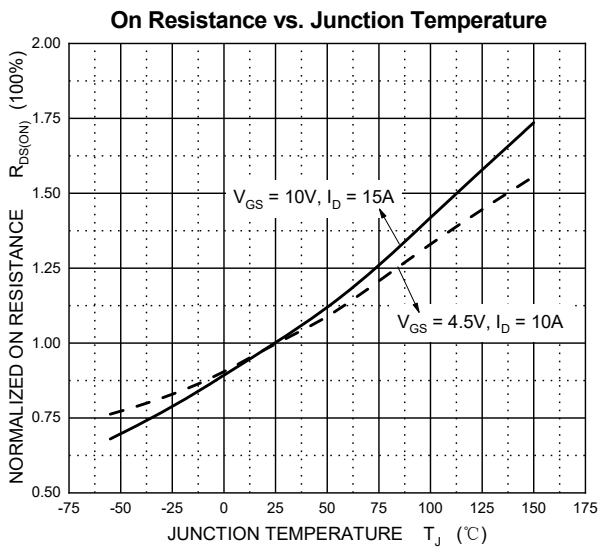
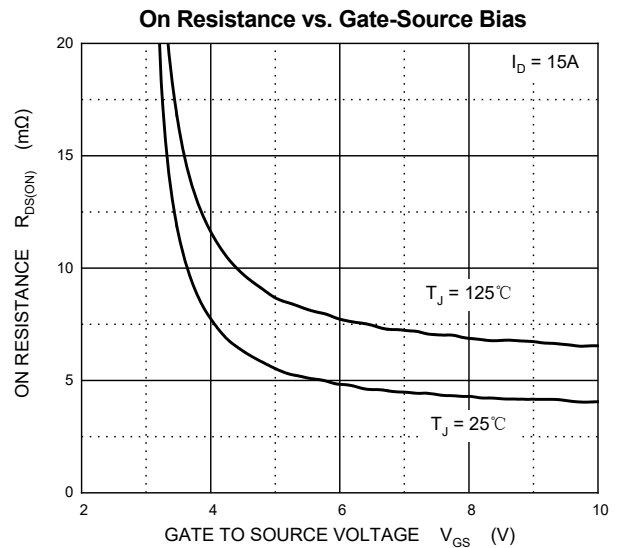
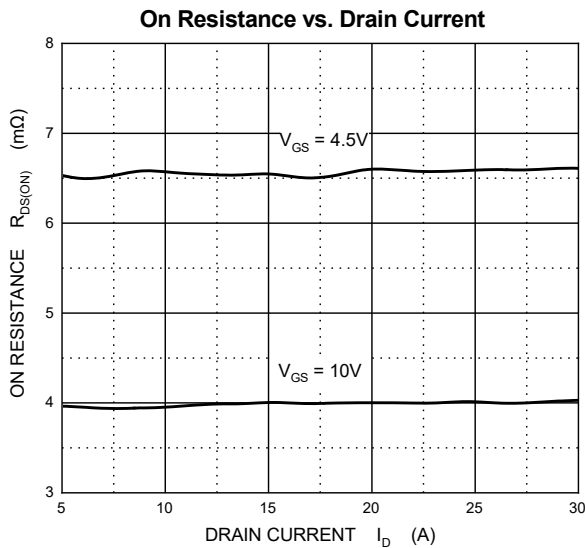
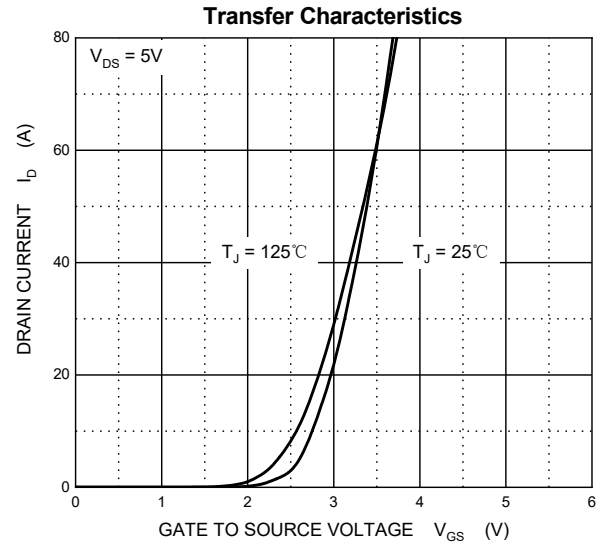
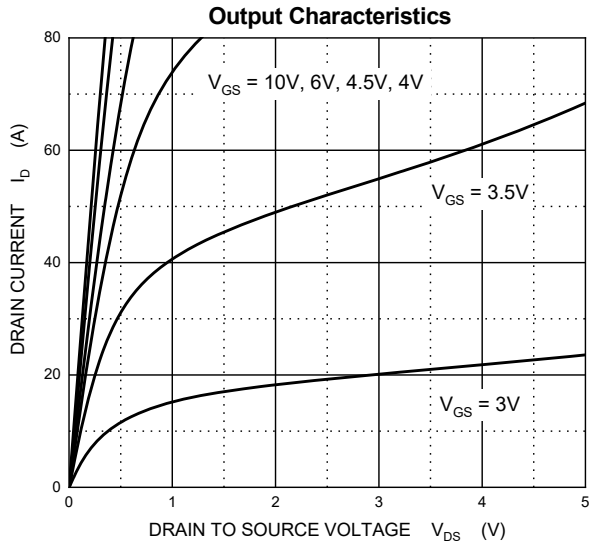

Typical Characteristics

Typical Capacitances

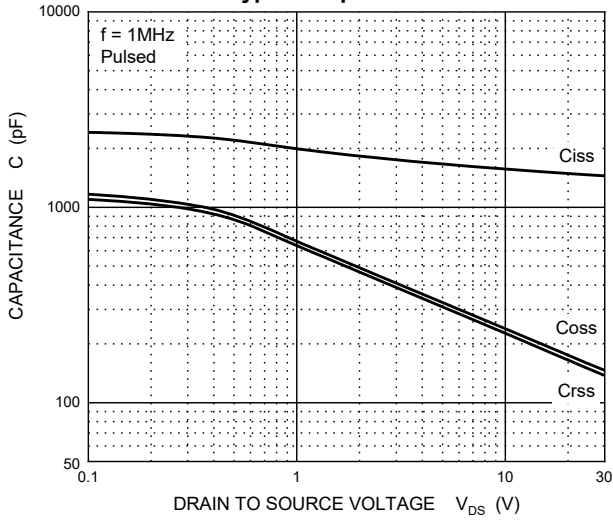

Gate Charge

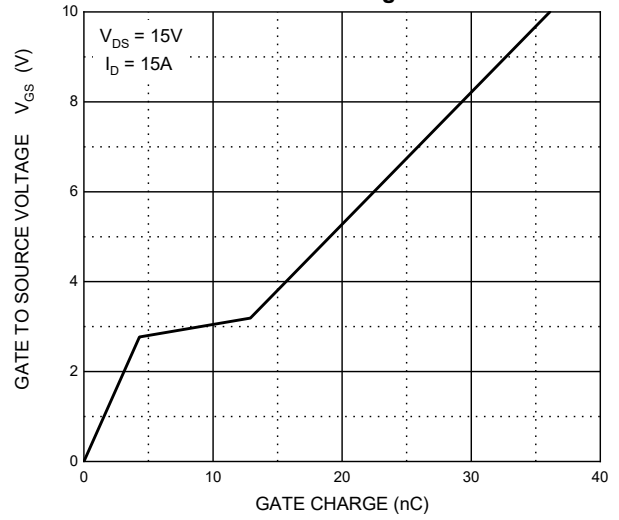

Source-Drain Diode Forward Characteristics

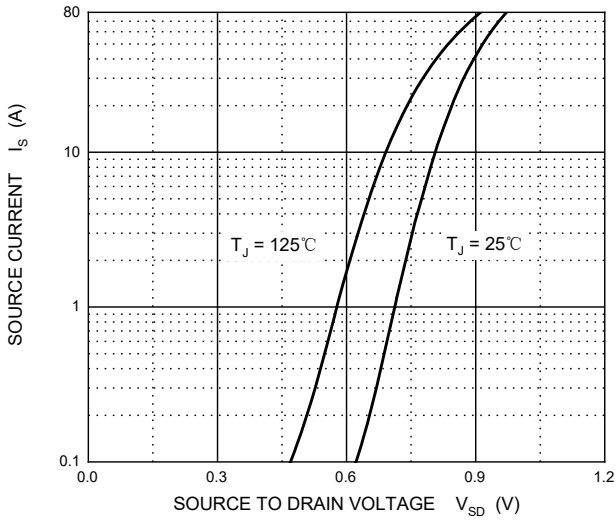

Drain-Source Breakdown Voltage

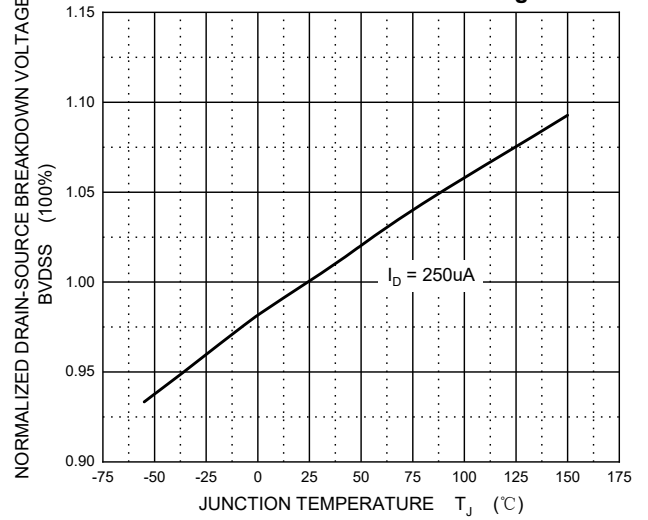

Maximum Safe Operating Area

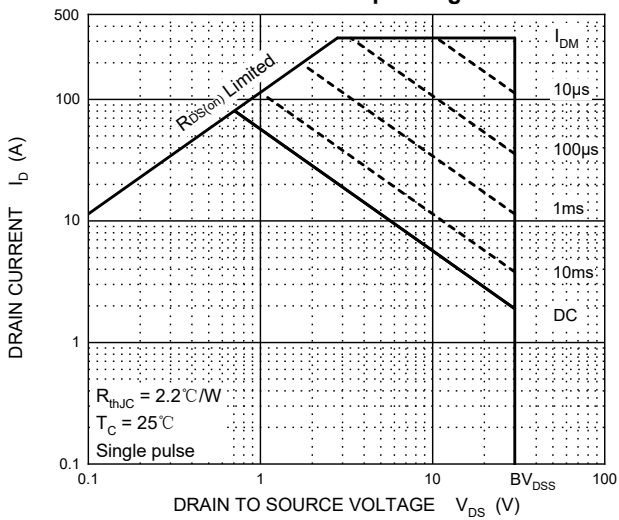

Transient Thermal Impedance, Junction-Case

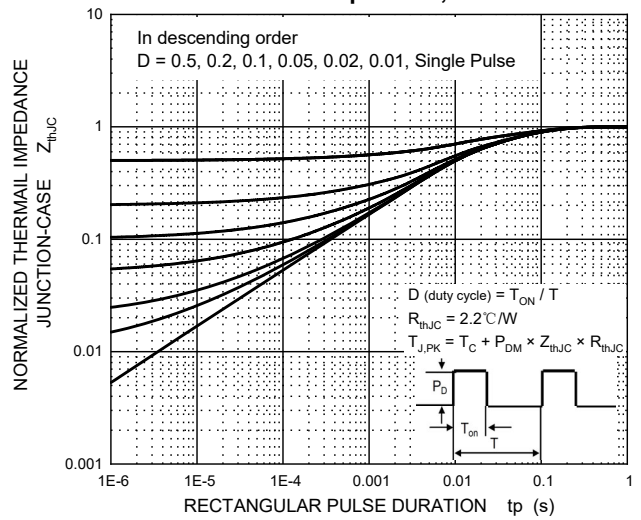

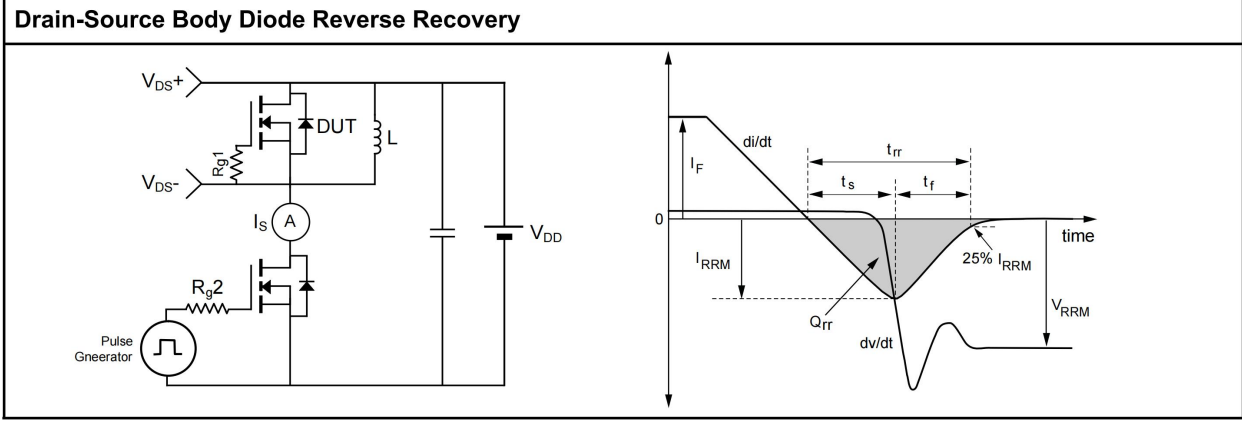
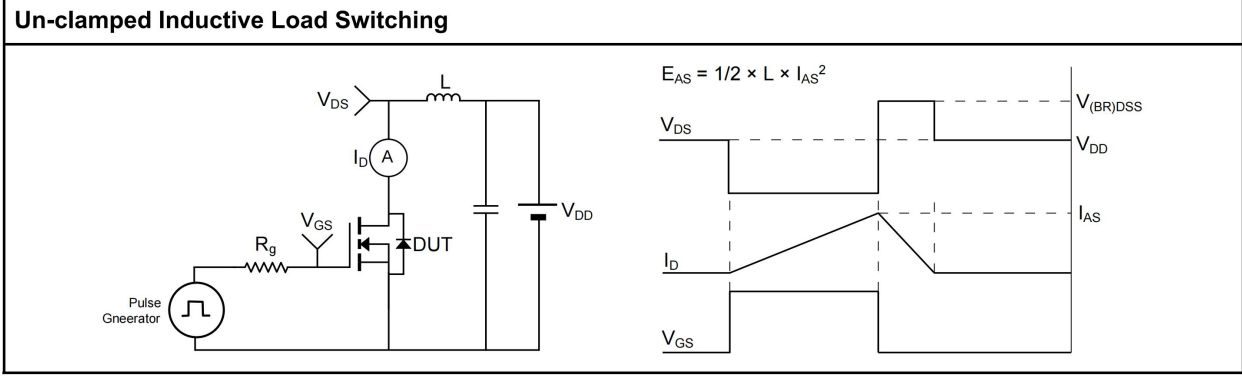
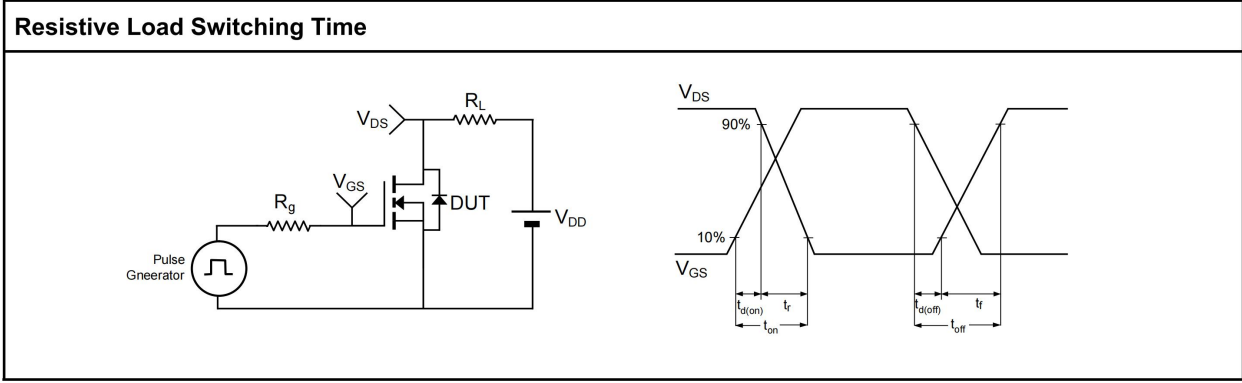
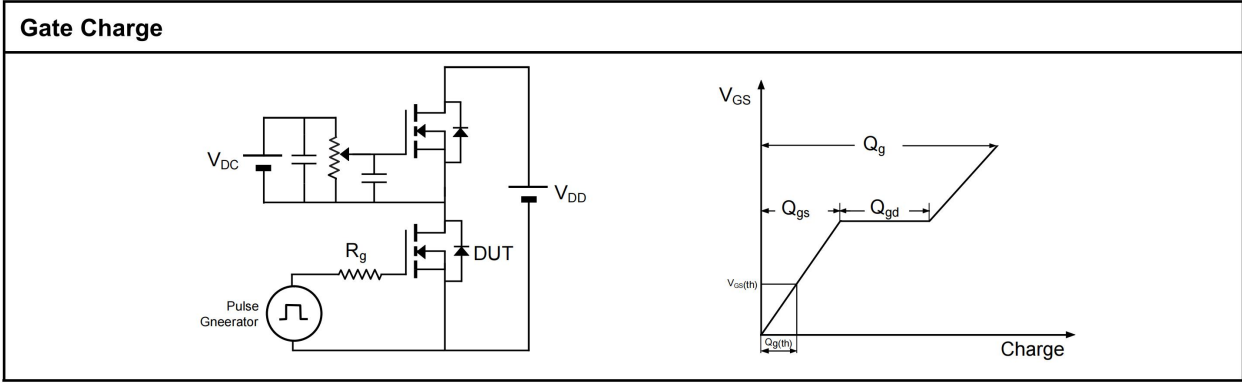

TO-252-2L Package Outline Dimensions

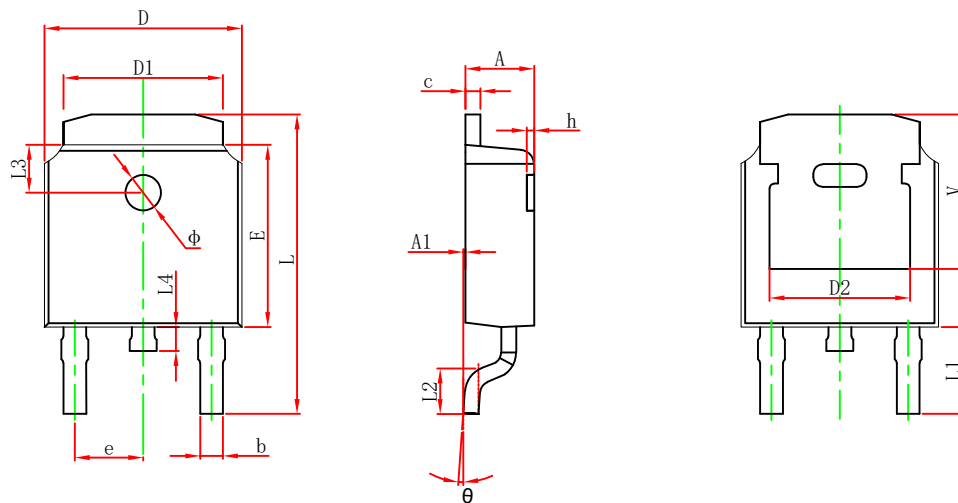

Symbol	Dimensions In Millimeters		Dimensions In Inches	
	Min.	Max.	Min.	Max.
A	2.200	2.400	0.087	0.094
A1	0.000	0.127	0.000	0.005
b	0.635	0.770	0.025	0.030
c	0.460	0.580	0.018	0.023
D	6.500	6.700	0.256	0.264
D1	5.100	5.460	0.201	0.215
D2	4.830 REF.		0.190 REF.	
E	6.000	6.200	0.236	0.244
e	2.186	2.386	0.086	0.094
L	9.712	10.312	0.382	0.406
L1	2.900 REF.		0.114 REF.	
L2	1.400	1.700	0.055	0.067
L3	1.600 REF.		0.063 REF.	
L4	0.600	1.000	0.024	0.039
Φ	1.100	1.300	0.043	0.051
θ	0°	8°	0°	8°
h	0.000	0.300	0.000	0.012
V	5.250 REF.		0.207 REF.	

TO-252-2L Suggested Pad Layout

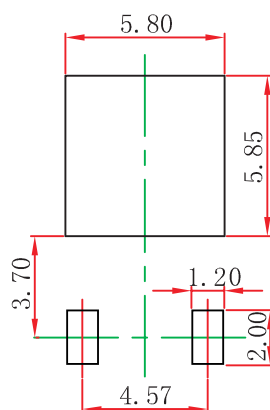

Note:

1. Controlling dimension: in millimeters.
2. General tolerance: $\pm 0.05\text{mm}$.
3. The pad layout is for reference purposes only.

NOTICE

JSCJ reserves the right to make modifications, enhancements, improvements, corrections or other changes without further notice to any product herein. JSCJ does not assume any liability arising out of the application or use of any product described herein.

TO-252-2L Tape and Reel

TO-252-2L Embossed Carrier Tape

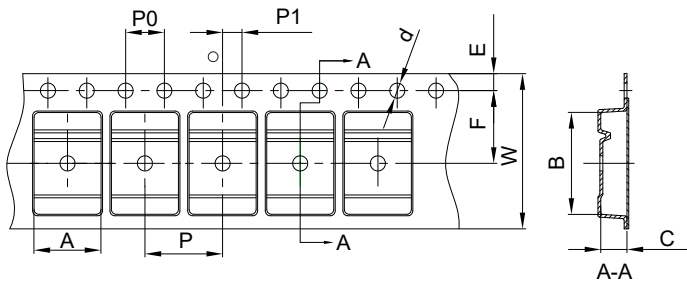

Packaging Description:

TO-252-2L parts are shipped in tape. The carrier tape is made from a dissipative (carbon filled) polycarbonate resin. The cover tape is a multilayer film (Hear Activated Adhesive in nature) primarily composed of polyester film, adhesive layer, sealant, and anti-static sprayed agent. These reeled parts in standard option are shipped with 2500 units per 13" or 33.0 cm diameter reel. The reels are clear in color and is made of polystyrene plastic (anti-static coated).

Dimensions are in millimeter										
Pkg type	A	B	C	d	E	F	P0	P	P1	W
TO-252	6.90	10.50	2.70	Φ1.55	1.75	7.50	4.00	8.00	2.00	16.00

TO-252-2L Tape Leader and Trailer

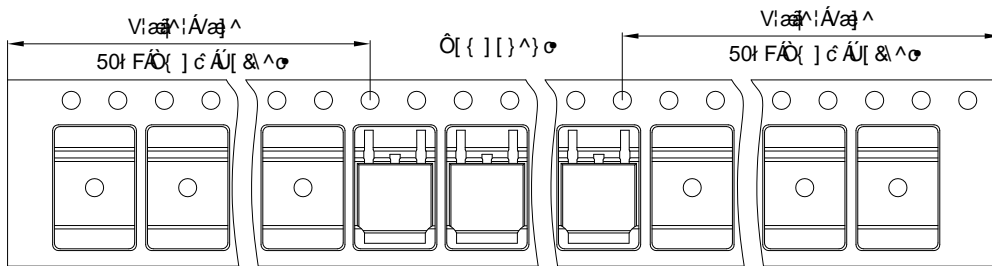

TO-252-2L Reel

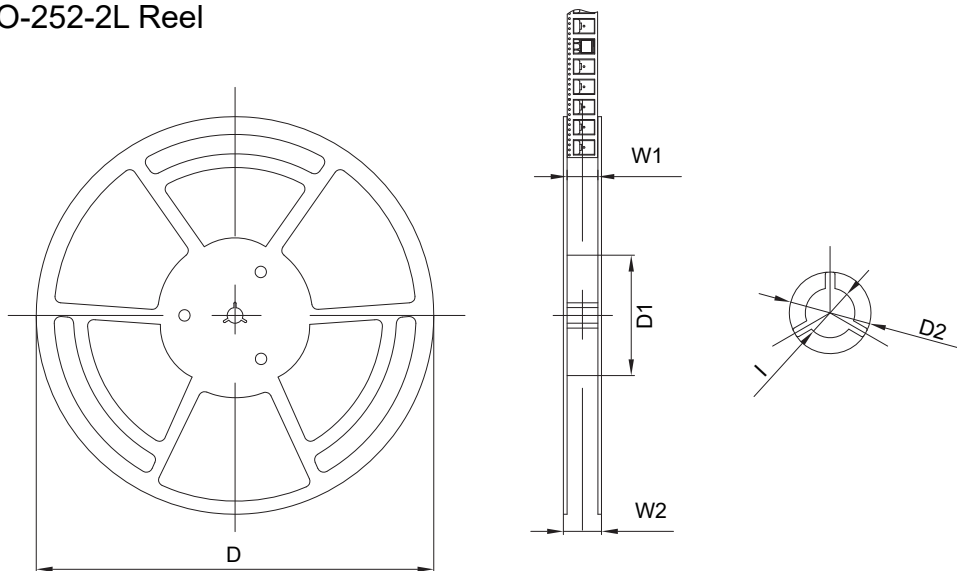

Dimensions are in millimeter						
Reel	D	D1	D2	W1	W2	l
13" Dia	330.00	100.00	Φ21.00	16.40	21.40	Φ13.00

Reel	Reel Size	Box	Box Size(mm)	Carton	Carton Size(mm)
2500 pcs	13 inch	5000 pcs	360×360×65	25000 pcs	378×358×382