

TO-247-A Plastic-Encapsulate MOSFET

CJWT035SN20MK N-Channel Power MOSFET

Key Performance Parameters

V_{BR(DSS)}	R_{DS(on)TYP}	I_D
200V	29mΩ@10V	55A

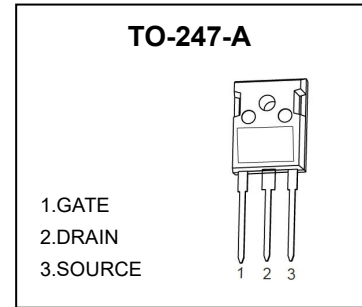

DESCRIPTION

The N-Channel enhancement mode power field effect transistors is using SGT technology. This advanced technology has been especially tailored to minimize on-state resistance, provide superior switching performance, and withstand high energy pulse in the avalanche and commutation mode. These devices are well suited for high efficiency fast switching applications.

FEATURES

- 100% Avalanche tested
- Low drain-source on-resistance
- Low gate charge
- High current capability

APPLICATIONS

- DC/DC
- Switching application

MARKING



XXXXXX = 035SN20MK
 Solid dot = Green molding compound device.
 YYYY = Code.

EQUIVALENT CIRCUIT

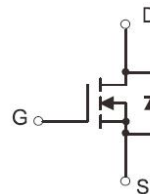

ABSOLUTE MAXIMUM RATINGS (T_J=25°C unless otherwise specified)

Parameter	Symbol	Value	Unit
Drain-Source Voltage	V _{DS}	200	V
Gate-Source Voltage	V _{GS}	±20	V
Continuous Drain Current	I _D	T _C =25°C	55
		T _C =100°C	35
Pulsed Drain Current	I _{DM} ^{①②}	220	A
Continuous Drain Current	I _D	T _A =25°C	7.1
		T _A =75°C	5.5
Avalanche Current	I _{AS} ^③	20	A
Single Pulsed Avalanche Energy	E _{AS} ^③	100	mJ
Power Dissipation	P _D ^①	278	W
Operating Junction and Storage Temperature Range	T _J , T _{stg}	-55~+150	°C

Thermal Characteristics

Parameter	Symbol	Value		Unit
		Typ	Max	
Thermal Resistance from Junction to Case	R _{θJC}	0.30	0.45	°C/W
Thermal Resistance from Junction to Ambient	R _{θJA} ^⑥	30	45	°C/W

Typical Characteristics

ELECTRICAL CHARACTERISTICS (T_J=25°C unless otherwise specified)

Static Characteristics

Parameter	Symbol	Test Condition	Value			Unit	
			Min	Typ	Max		
Drain-source breakdown voltage	V _{(BR)DSS}	V _{GS} =0V, I _D =250μA	200	-	-	V	
Zero gate voltage drain current	I _{DSS}	V _{DS} =200V, V _{GS} =0V	T _J =25°C	-	-	1.0	μA
			T _J =125°C	-	-	100	
Gate-body leakage current	I _{GSS}	V _{GS} =±20V, V _{DS} =0V	-	-	±100	nA	
Gate-threshold voltage	V _{GS(th)}	V _{DS} =V _{GS} , I _D =250μA	2.0	3.2	4.0	V	
Static drain-source on-state resistance	R _{Ds(on)} ^④	V _{GS} =10V, I _D =20A	T _J =25°C	-	29	35	mΩ
			T _J =125°C	-	60	73	
Forward transconductance	g _{FS}	V _{DS} =5V, I _D =20A	-	43	-	S	

Dynamic Characteristics^⑤

Input capacitance	C _{iss}	V _{GS} =0V, V _{DS} =100V, f=1MHz	-	1527	-	pF
Output capacitance	C _{oss}		-	141	-	
Reverse transfer capacitance	C _{rss}		-	8	-	
Gate resistance	R _g	f=1MHz	-	4.6	-	Ω
Total gate charge	Q _g	V _{GS} =10V, V _{DS} =100V, I _D =20A	-	18.7	-	nC
Gate charge at threshold	Q _{G(th)}		-	4.7	-	
Gate-source charge	Q _{gs}		-	6.8	-	
Gate-drain charge	Q _{gd}		-	2.7	-	
Turn-on delay time	t _{d(on)}	V _{DD} =100V, V _{GS} =10V, I _D =20A, R _g =10Ω	-	21	-	ns
Turn-on rise time	t _r		-	21	-	
Turn-off delay time	t _{d(off)}		-	28	-	
Turn-off fall time	t _f		-	33	-	

Reverse Diode Characteristics

Drain-source diode forward voltage	V _{SD} ^④	V _{GS} =0V, I _S =20A	-	-	1.2	V
Continuous drain-source diode forward current	I _S ^①		-	-	55	A
Pulsed drain-source diode forward current	I _{SM} ^{①②}		-	-	220	A
Reverse recovery time	t _{rr}	V _{DD} =100V, I _S =20A,	-	106	-	ns
Reverse recovery charge	Q _{rr}	di/dt=100A/μs	-	393	-	nC

Notes:

- ①.T_C=25°C Limited only by maximum temperature allowed.
- ②.P_w≤10μs, Duty cycle ≤1%.
- ③.EAS condition: V_{DD}=100V, V_{GS}=10V, L=0.5mH, R_g=25Ω Starting T_J=25°C.
- ④.Pulse Test : Pulse Width ≤380μs, duty cycle ≤2%.
- ⑤.Guaranteed by design, not subject to production.
- ⑥.Device mounted in a still air environment with T_A=25°C.

Typical Characteristics

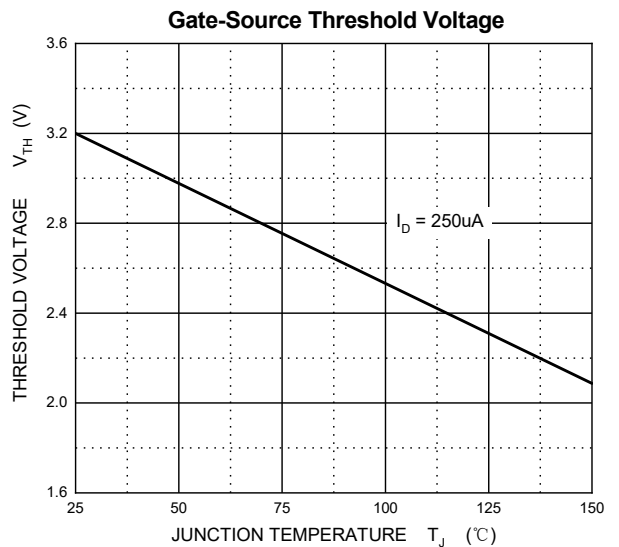
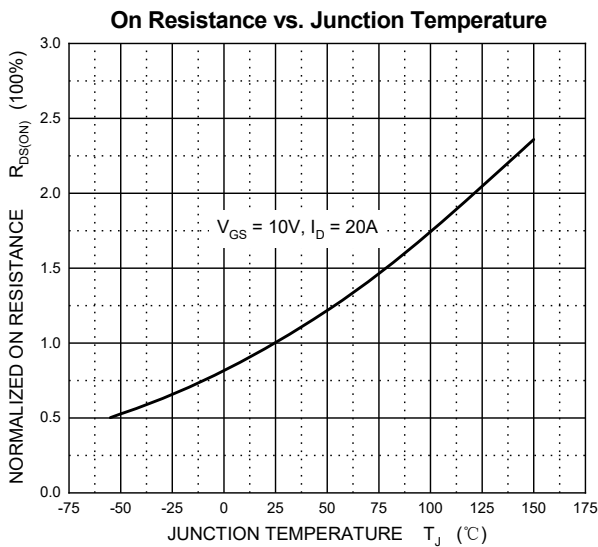
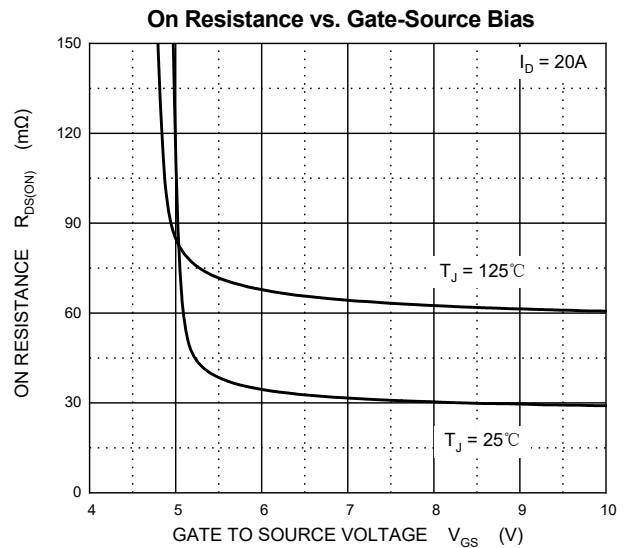
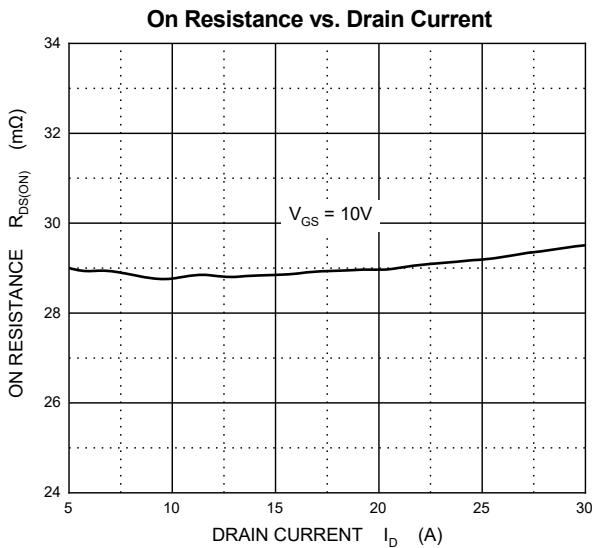
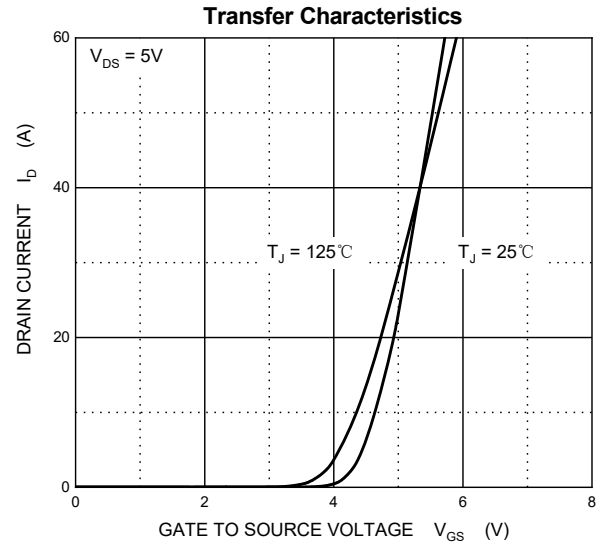
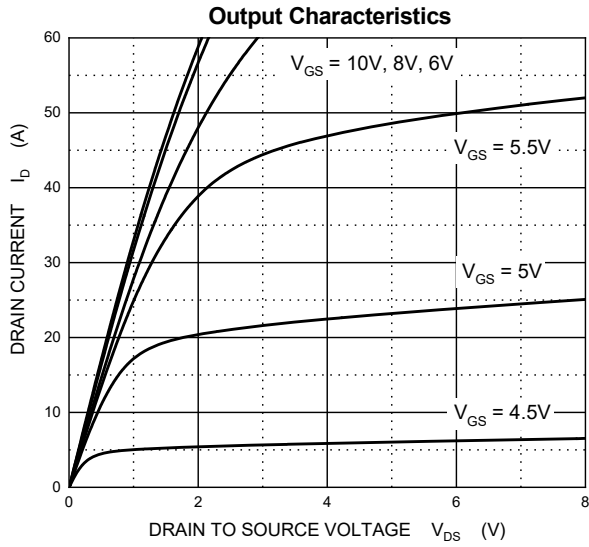

Typical Characteristics

Typical Capacitances

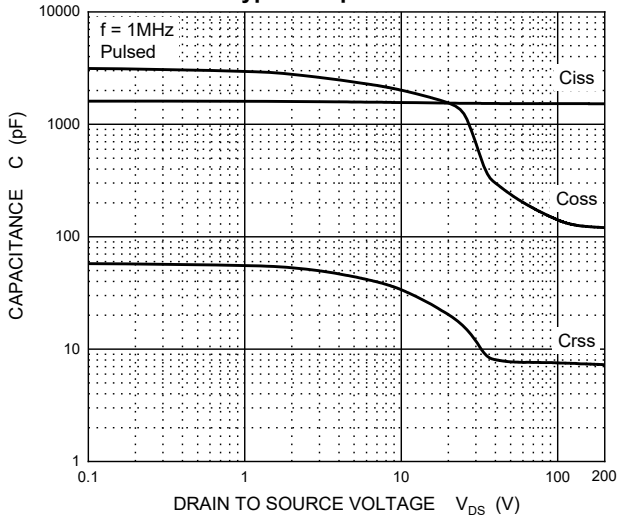

Gate Charge

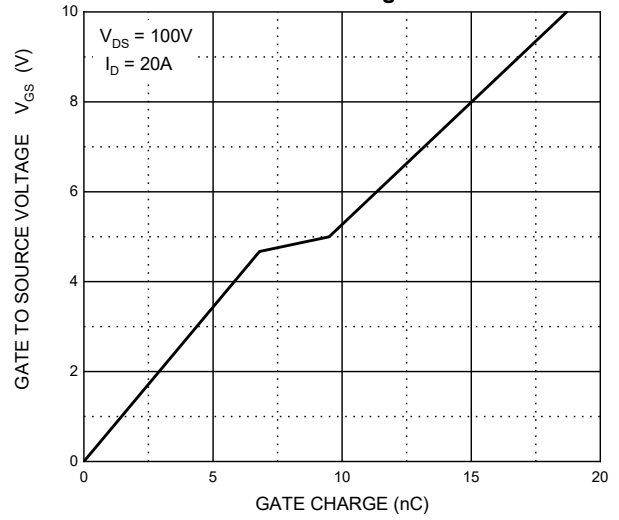

Source-Drain Diode Forward Characteristics

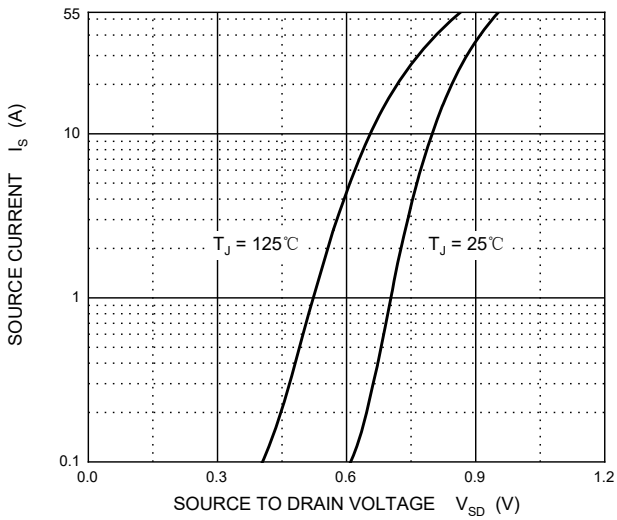

Drain-Source Breakdown Voltage

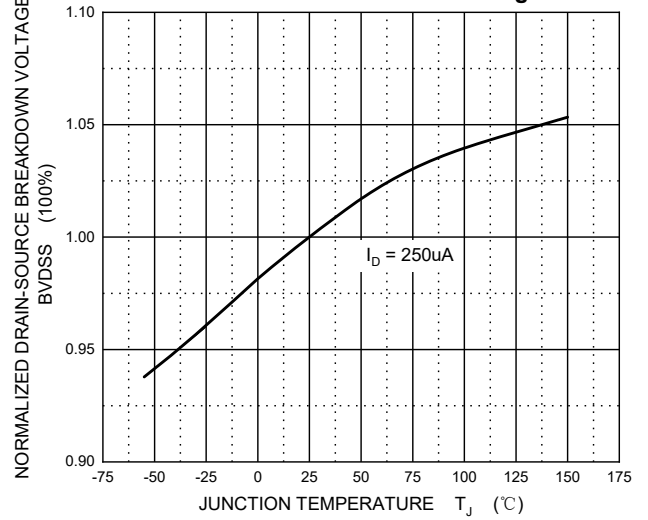

Maximum Safe Operating Area

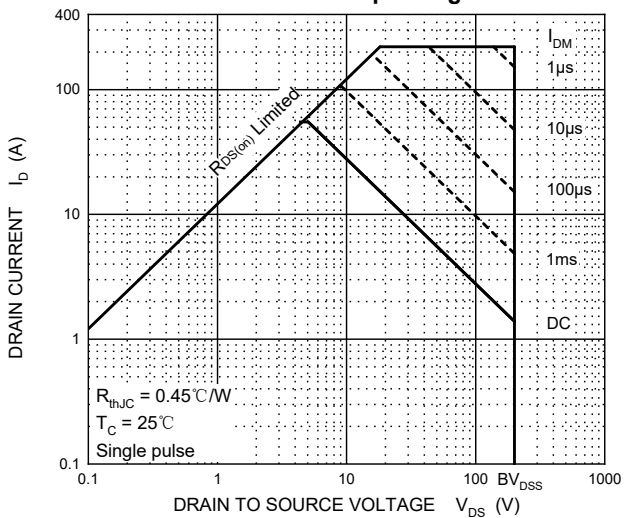

Transient Thermal Impedance, Junction-Case

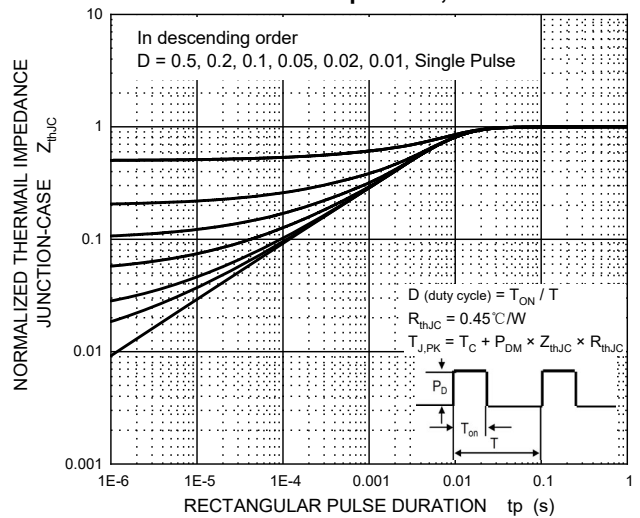

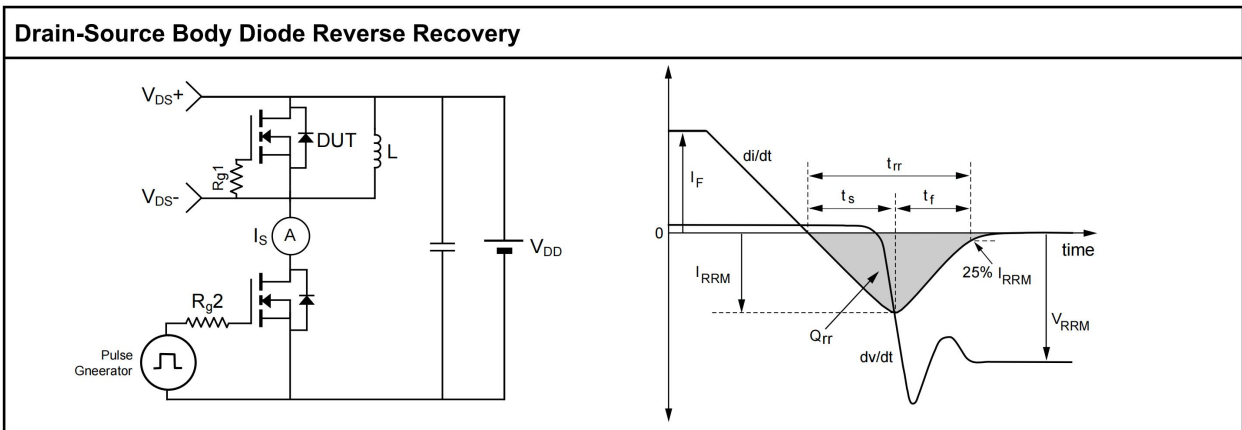
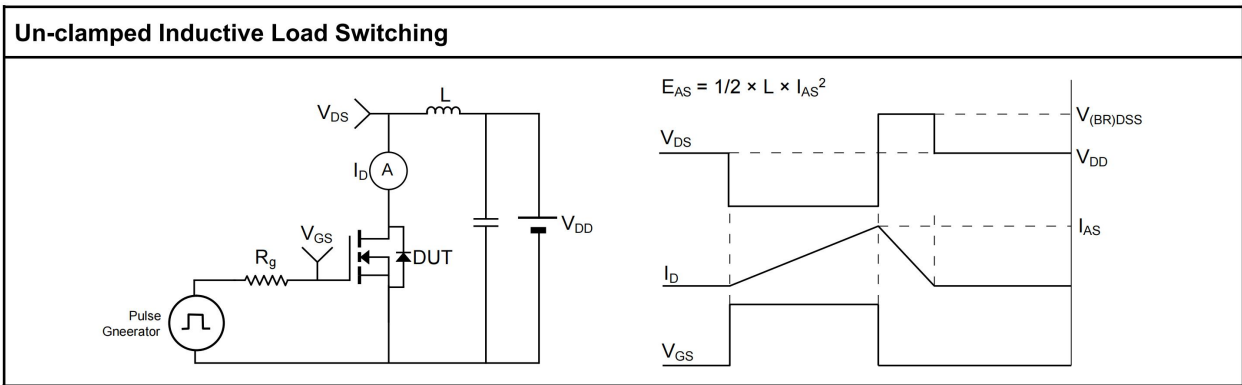
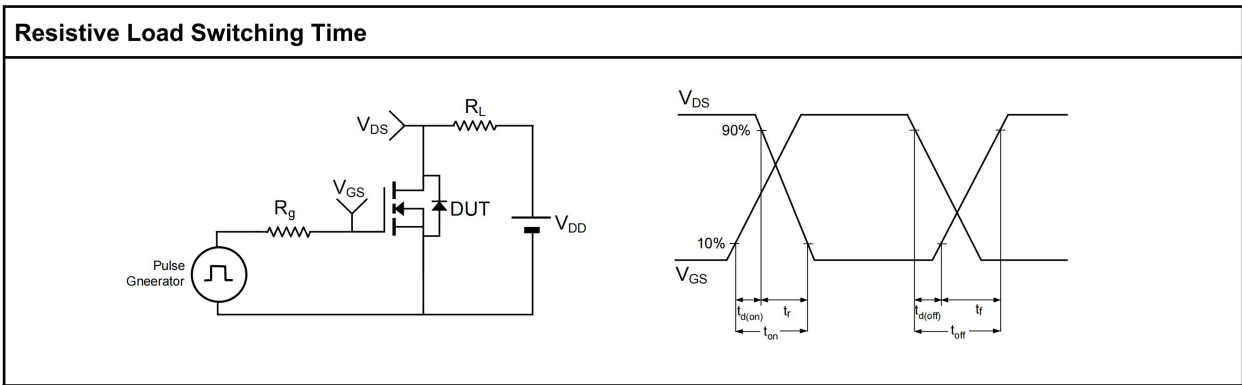
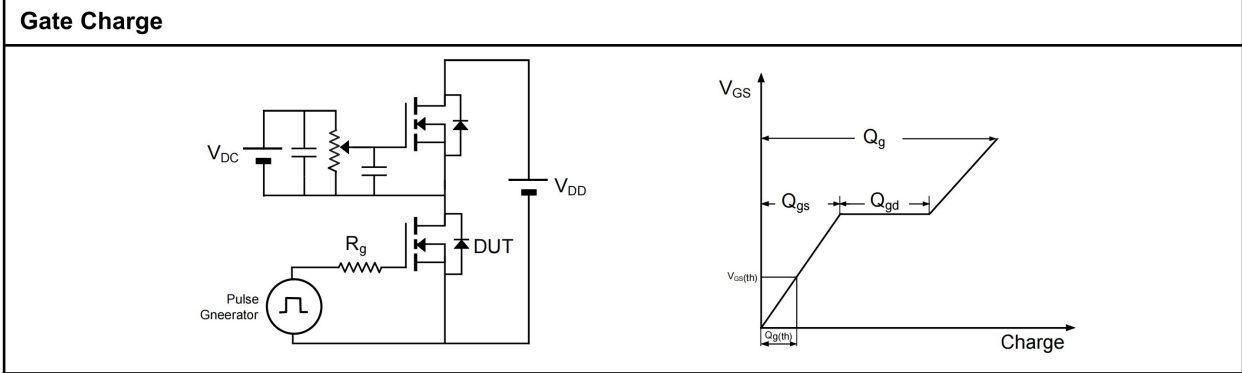

TO-247-A Package Outline Dimensions

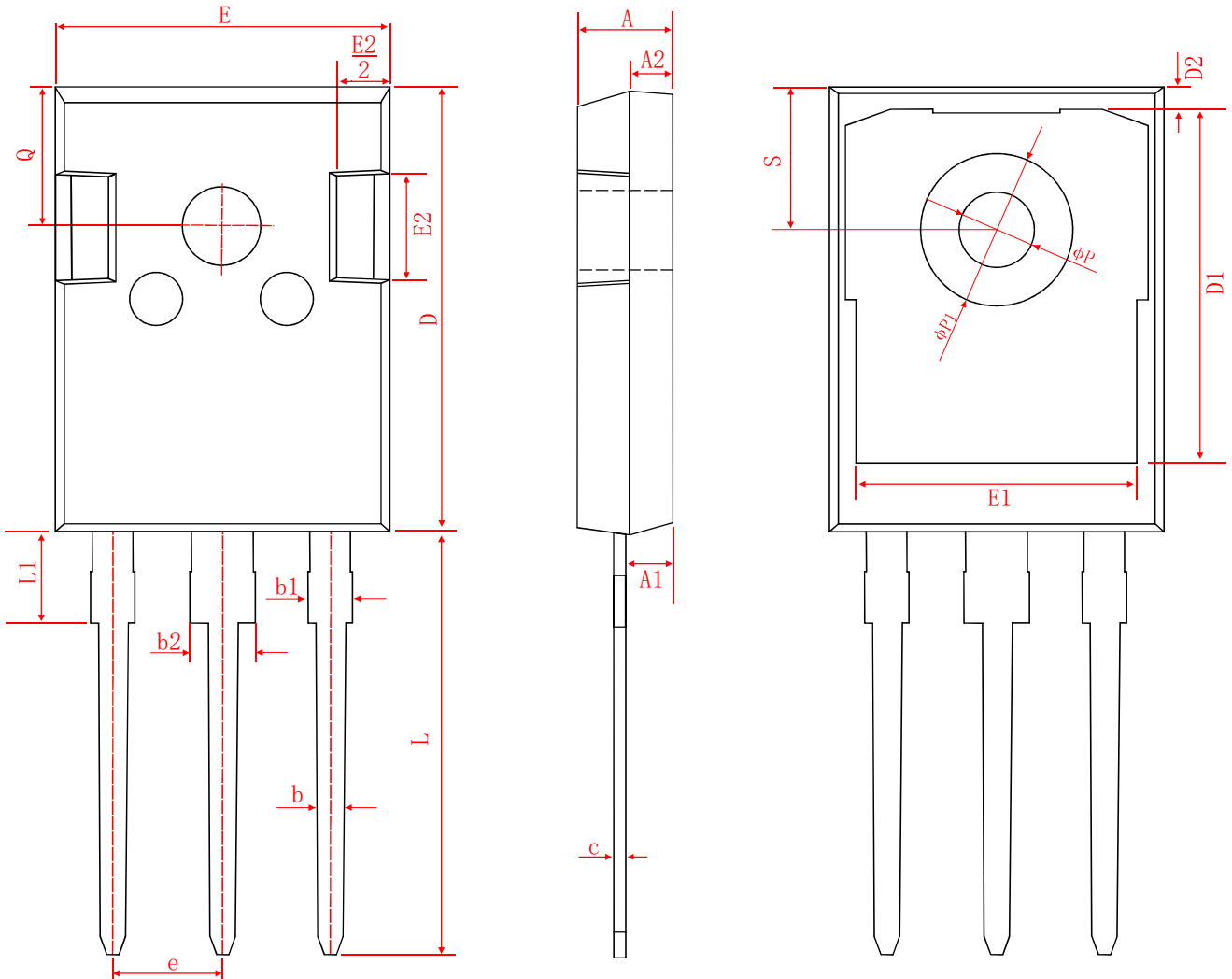

Symbol	Dimensions In Millimeters		Dimensions In Inches	
	Min	Max	Min	Max
A	4.90	5.10	0.193	0.201
A1	2.31	2.51	0.091	0.099
A2	1.90	2.10	0.075	0.083
b	1.15	1.25	0.045	0.049
b1	1.95	2.25	0.077	0.089
b2	2.95	3.25	0.116	0.128
c	0.55	0.65	0.022	0.026
D	20.90	21.10	0.823	0.831
D1	16.35	16.75	0.644	0.659
D2	1.05	1.35	0.041	0.053
e	5.44 TYP.		0.214 TYP.	
E	15.70	15.90	0.618	0.626
E1	13.10	13.40	0.516	0.528
E2	4.90	5.10	0.193	0.201
Q	5.60	6.00	0.220	0.236
S	6.05	6.25	0.238	0.246
L	19.80	20.15	0.780	0.793
L1		4.30		0.169
ΦP	3.45	3.65	0.136	0.144
ΦP1	7.03	7.33	0.277	0.289