



TO-247-2L Plastic-Encapsulate Diode

CSDW30H65 Silicon Carbide Schottky Diode

MAIN CHARACTERISTICS

I_o	30A ($T_c \leq 130^\circ\text{C}$)
V_{RRM}	650V
T_j	175 °C
$V_{F(\text{typ})}$	1.42V (@ $T_j=25^\circ\text{C}$) 1.86V (@ $T_j=175^\circ\text{C}$)

FEATURES

- Zero Reverse Recovery Current
- Zero Forward Recovery Voltage
- Temperature-independent performance
- High-speed switching
- Low switching loss
- Low Leakage Current

Application

- Industrial Power Supplies
- Power factor correction
- Motor drive traction
- EV charging station
- Solar Inverters

MARKING

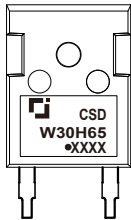

CSDW30H65= Device code
Solid dot = Green molding compound device
if none, the normal device
XXXX = Code

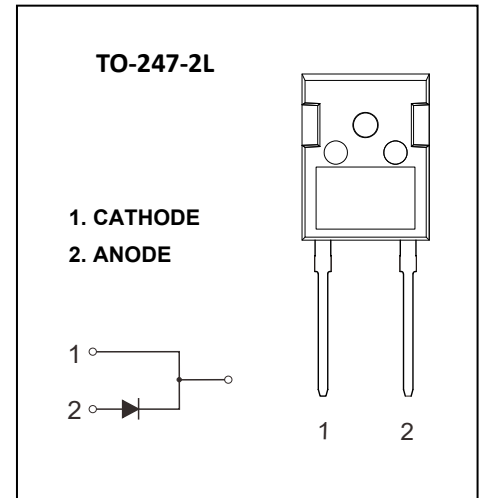

MAXIMUM RATINGS ($T_j=25^\circ\text{C}$ unless otherwise noted)

Symbol	Parameter	Value	Unit	
V_{RRM}	Peak repetitive reverse voltage	650	V	
V_{RWM}	Working peak reverse voltage			
V_R	DC blocking voltage			
$I_{F(AV)}$	Average Forward Current	$T_c \leq 25^\circ\text{C}$	63	A
		$T_c \leq 100^\circ\text{C}$	42	A
		$T_c \leq 130^\circ\text{C}$	30	A
I_{FSM}	Non-Repetitive peak forward surge current (10 ms half sine wave)	200	A	
$\int i^2 dt$	$\int i^2 dt$ value ($t_p=10\text{ms}$)	200	A ² s	
P_D	Power dissipation	197	W	
$R_{\theta JC}$	Thermal Resistance From Junction to Case	0.76	°C/W	
T_j	Junction temperature	-55~175	°C	
T_{stg}	Storage temperature	-55~175	°C	

Typical Characteristics

ELECTRICAL CHARACTERISTICS ($T_j=25^\circ\text{C}$ unless otherwise specified)

Parameter	Symbol	Test conditions	Min	Typ	Max	Unit
Reverse voltage	$V_{(BR)}$	$I_R=100\mu\text{A}$	650			V
Reverse current	I_R	$V_R=650\text{V}$	$T_j=25^\circ\text{C}$	2	20	μA
			$T_j=175^\circ\text{C}$	15	200	μA
Forward voltage	V_F	$I_F=30\text{A}$	$T_j=25^\circ\text{C}$	1.42	1.8	V
			$T_j=175^\circ\text{C}$	1.86	2.4	V
Total capacitance	C	$V_R=0\text{V}, f=1\text{MHz}$		1516		pF
		$V_R=200\text{V}, f=1\text{MHz}$		142		pF
		$V_R=400\text{V}, f=1\text{MHz}$		141		pF
Total capacitive charge	Q_C	$V_R=400\text{V}$ $Q_C = \int_0^{V_R} C(V) dV$		85		nC
Capacitance Stored Energy	E_C	$V_R=400\text{V}$ $E_C = \int_0^{V_R} C(V) \cdot V dV$		14		μJ

Typical Characteristics

Forward Characteristics

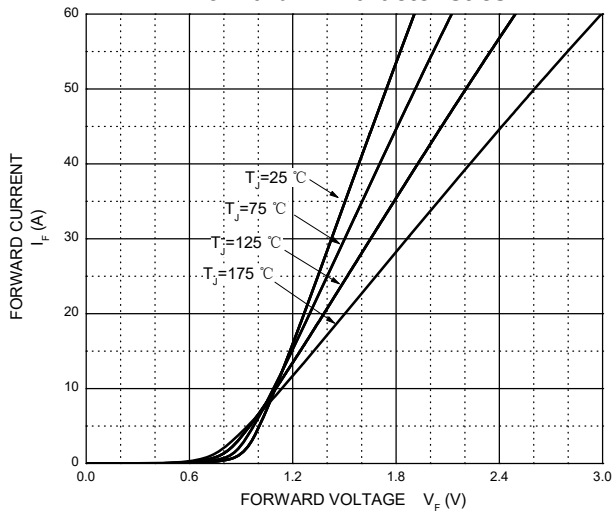

Reverse Characteristics

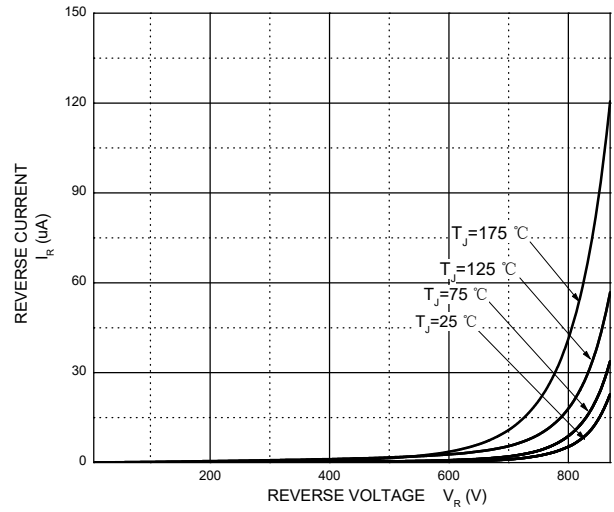

Capacitance Characteristics Per Diode

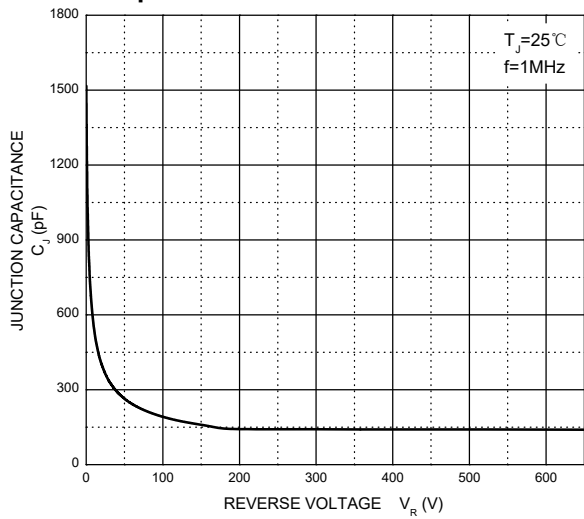

Total Capacitive Charge vs. Reverse Voltage

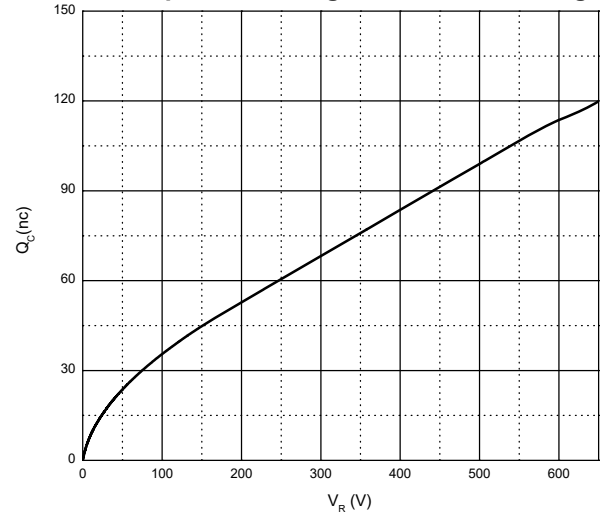

Capacitance Stored Energy

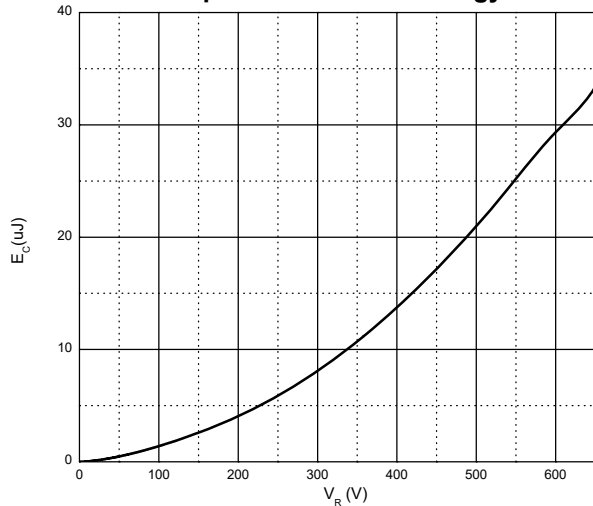

Power Derating Curve

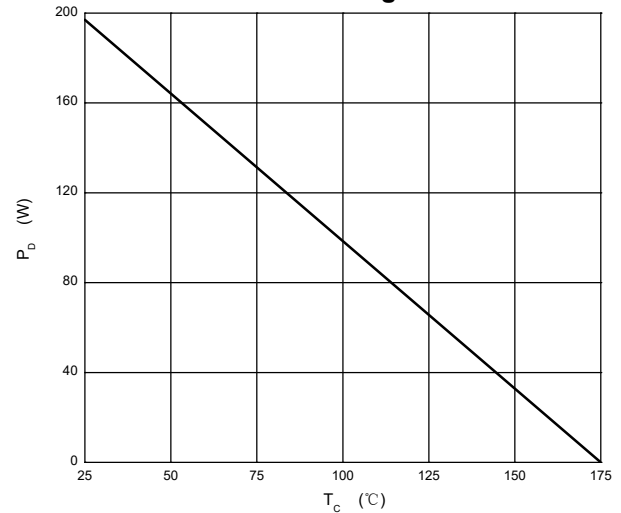

Typical Characteristics

Current Derating

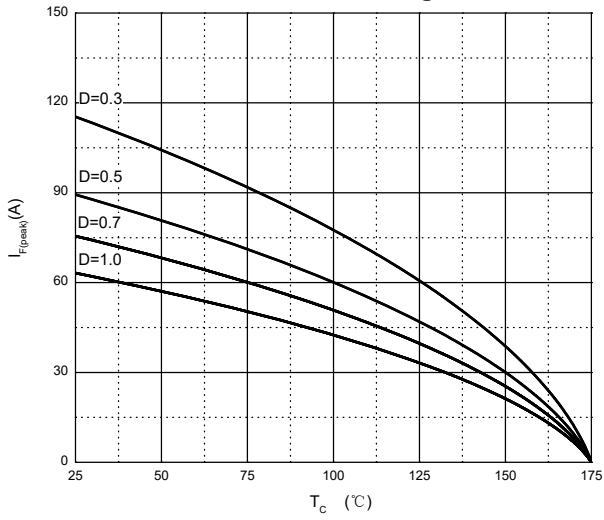

CSDW30H65 Transient Thermal Impedance, Junction-Case

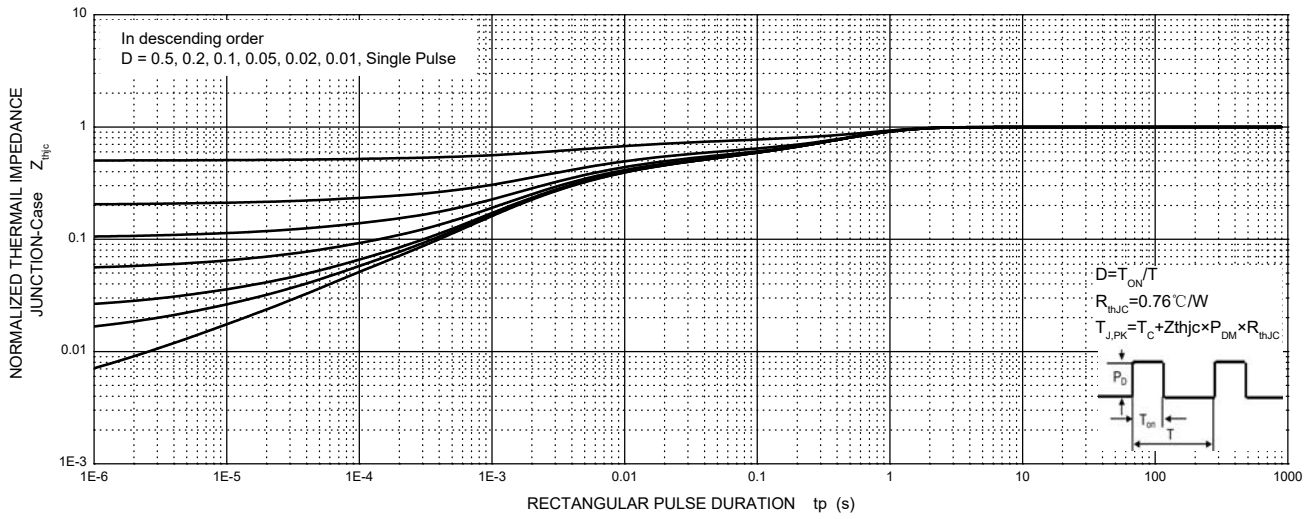

TO-247-2L PACKAGE OUTLINE DIMENSIONS

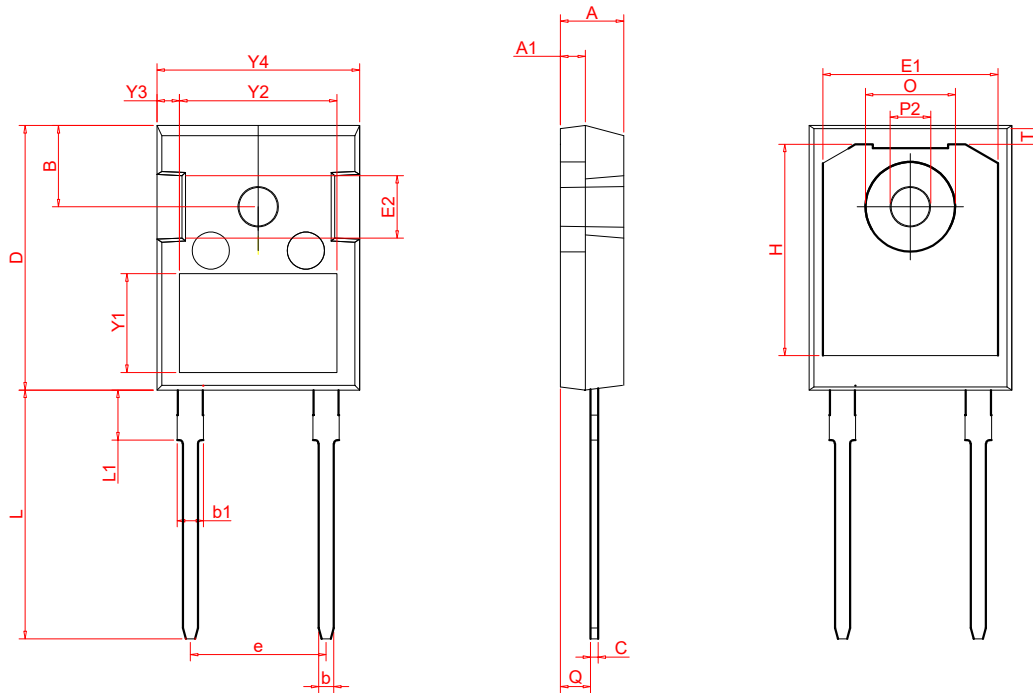

Symbol	Dimensions In Millimeters		Dimensions In Inches	
	Min	Max	Min	Max
A	4.70	5.30	0.185	0.209
A1	1.70	2.30	0.067	0.091
C	0.45	0.75	0.018	0.030
Q	2.20	2.60	0.087	0.102
O	7.10	7.40	0.280	0.291
P2	3.45	3.75	0.136	0.148
L	19.00	21.00	0.748	0.827
L1	4.20	4.50	0.165	0.177
b	1.00	1.40	0.039	0.055
b1	1.80	2.25	0.071	0.089
e	10.65	10.95	0.419	0.431
D	20.95	21.35	0.825	0.841
Y1	7.60	8.10	0.299	0.319
Y2	11.00	13.00	0.433	0.512
Y3	1.75	2.25	0.069	0.089
Y4	16.00	16.40	0.630	0.646
E2	4.60	4.90	0.181	0.193
T	1.35REF		0.053REF	
H	16.25REF		0.640REF	
E1	14.00REF		0.551REF	
B	6.55REF		0.258REF	