



DS52\$-40A1 Schottky Barrier Diode

FEATURES

- Small surface mounting type
- Low I_R
- High reliability

MARKING: D1

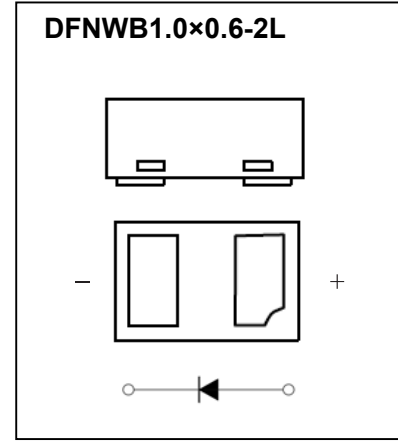

Maximum Ratings and Electrical Characteristics, Single Diode @ $T_A=25^\circ\text{C}$

Parameter	Symbol	Limit	Unit
DC reverse voltage	V_R	40	V
Mean rectifying current	I_o	0.2	A
Non-repetitive peak forward surge current@ $t=8.3\text{ms}$	I_{FSM}	1	A
Power Dissipation	P_D	100	mW
Thermal resistance from junction to ambient	$R_{\theta JA}$	1000	$^\circ\text{C}/\text{W}$
Operating Junction Temperature Range	T_J	-40 ~ +125	$^\circ\text{C}$
Storage Temperature Range	T_{STG}	-55 ~ +150	

Electrical Ratings @ $T_A=25^\circ\text{C}$

Parameter	Symbol	Min	Typ	Max	Unit	Conditions
Forward voltage	V_F			0.39 0.55	V	$I_F=10\text{mA}$ $I_F=100\text{mA}$
Reverse current	I_R			1 10	μA	$V_R=10\text{V}$ $V_R=40\text{V}$

Typical Characteristics

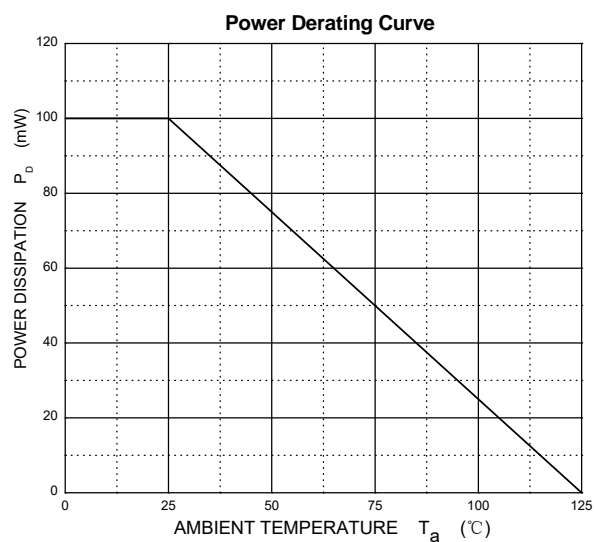
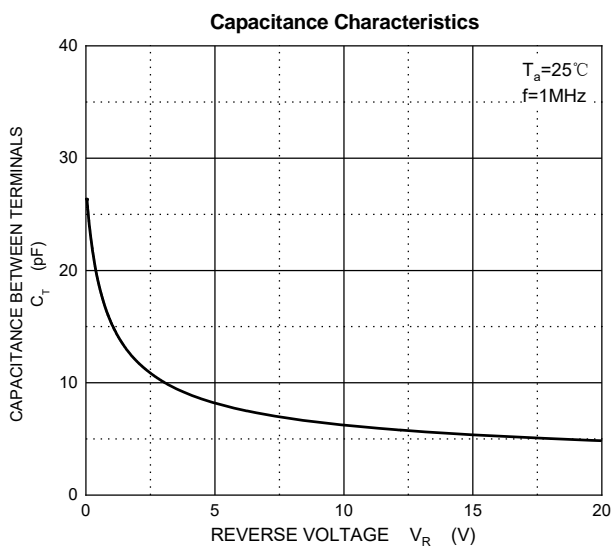
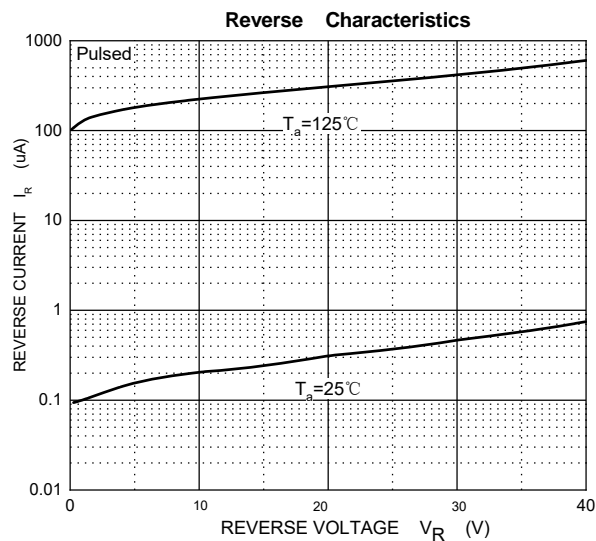
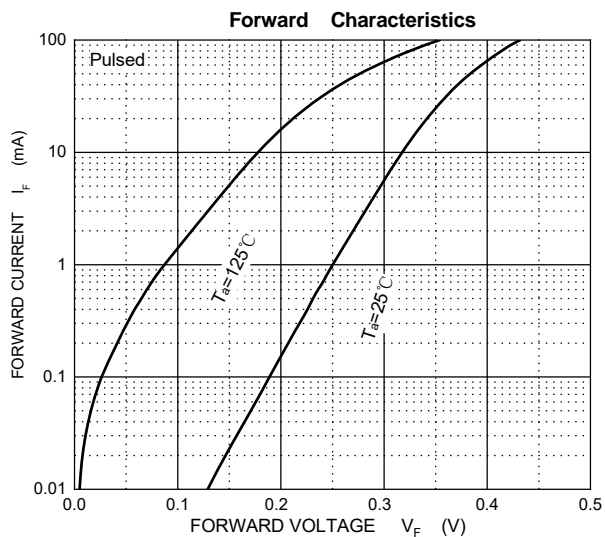

DFNWB1.0x 0.6-2L Package Outline Dimensions

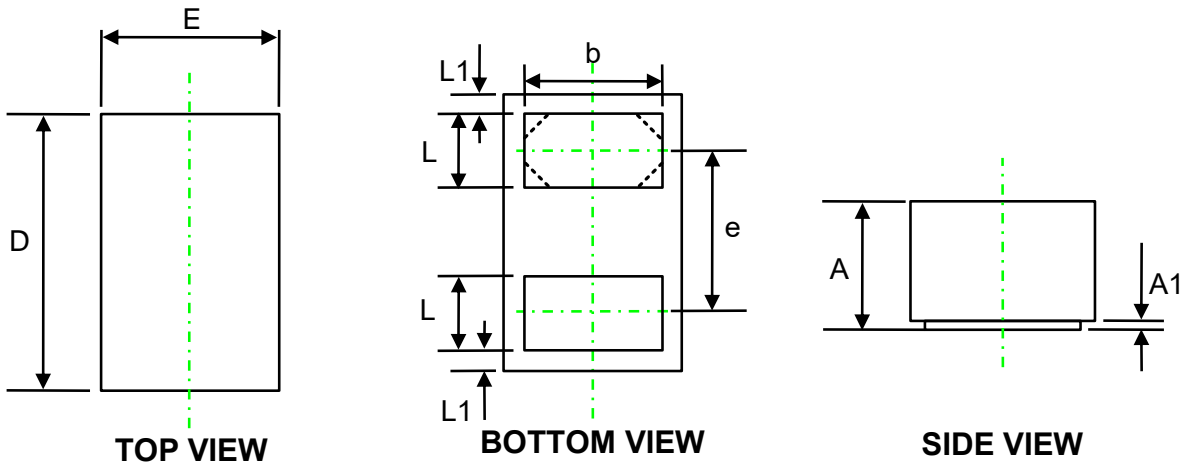

Symbol	Dimensions In Millimeters (mm)		
	Min.	Typ.	Max.
A	0.40	0.45	0.50
A1	0.00	0.03	0.05
D	0.95	1.00	1.08
E	0.55	0.60	0.68
b	0.40	0.50	0.60
e	-	0.65	-
L	0.20	0.25	0.30
L1	0.05 REF.		

DFNWB1.0x 0.6-2L Suggested Pad Layout

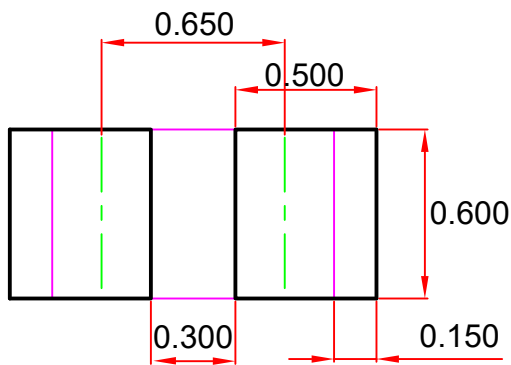

Note:
 1. Controlling dimension: in millimeters.
 2. General tolerance: ± 0.050 mm.
 3. The pad layout is for reference purposes only.

NOTICE

JSCJ reserves the right to make modifications, enhancements, improvements, corrections or other changes without further notice to any product herein. JSCJ does not assume any liability arising out of the application or use of any product described herein.

DFN/FBP(1.0×0.6×0.5) Embossed Carrier Tape

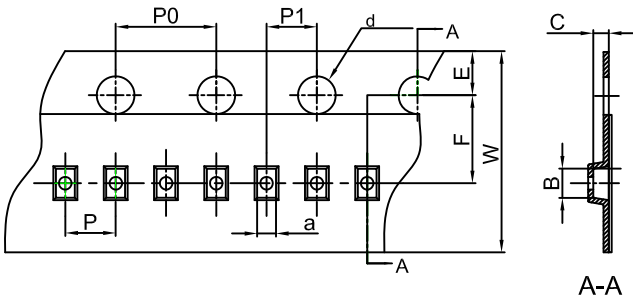

Packaging Description:
DFN/FBP(1.0×0.6×0.5) parts are shipped in tape. The carrier tape is made from a dissipative (carbon filled) polycarbonate resin. The cover tape is a multilayer film (Heat Activated Adhesive in nature) primarily composed of polyester film, adhesive layer, sealant, and anti-static sprayed agent. These reeled parts in standard option are shipped with 10,000 units per 7" or 17.8cm diameter reel. The reels are clear in color and is made of polystyrene plastic (anti-static coated).

Dimensions are in millimeter										
Pkg type	a	B	C	d	E	F	P0	P	P1	W
DFN/FBP(1.0×0.6×0.5)	0.66	1.15	0.66	Ø1.50	1.75	3.50	4.00	2.00	2.00	8.00

DFN/FBP(1.0×0.6×0.5) Tape Leader and Trailer

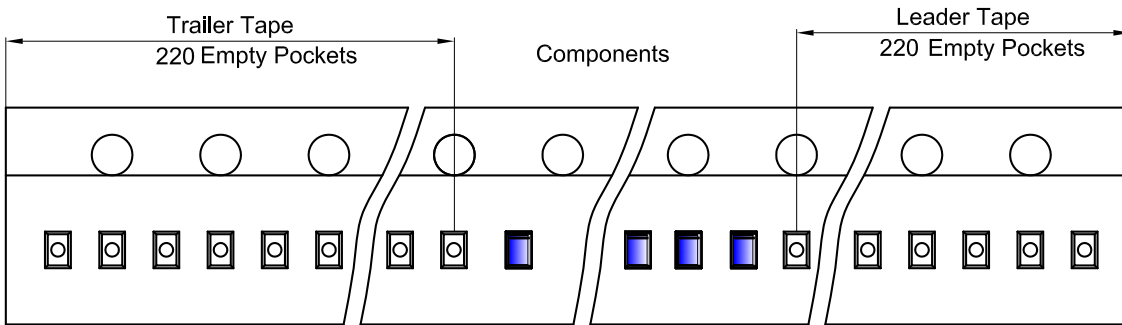

DFN/FBP(1.0×0.6×0.5) Reel

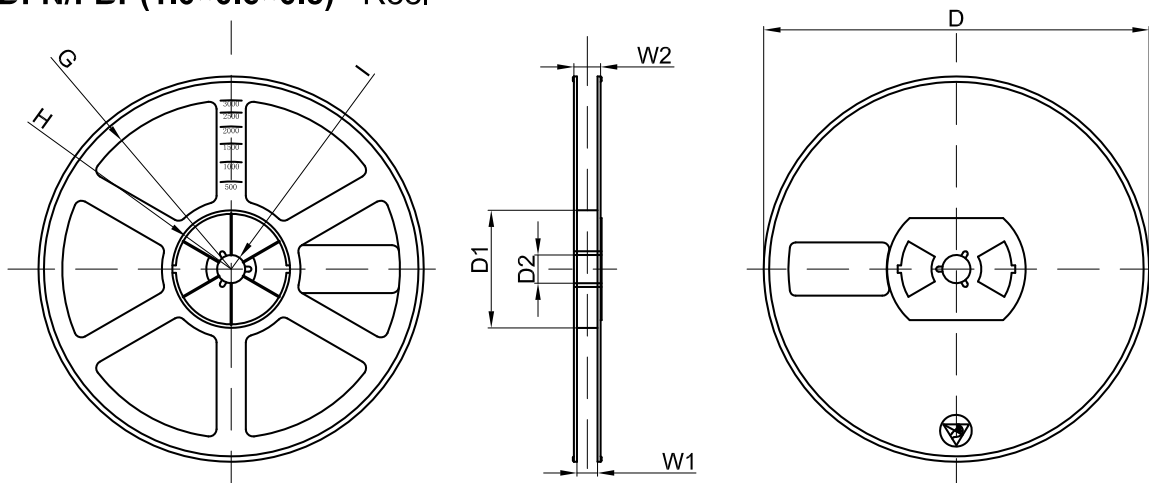

Dimensions are in millimeter								
Reel Option	D	D1	D2	G	H	I	W1	W2
7" Dia	Ø178.00	54.40	13.00	R78.00	R25.60	R6.50	9.50	12.30

REEL	Reel Size	Box	Box Size(mm)	Carton	Carton Size(mm)	G.W.(kg)
10000 pcs	7 inch	150,000 pcs	203×203×195	600,000 pcs	438×438×220	