



WBFBP-02C Plastic-Encapsulate Diodes

DW52C2V7LED02-DW52C43LED02

ZENER DIODE

FEATURES

- Ultra-Small Leadless Surface Mount Package
- Ideally Suited for Automated Assembly Processes

Marking:

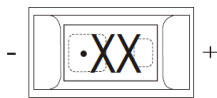

XX= Device code, see table on page2 the marking code

The marking bar indicates the cathode

Solid dot = Cathode point.

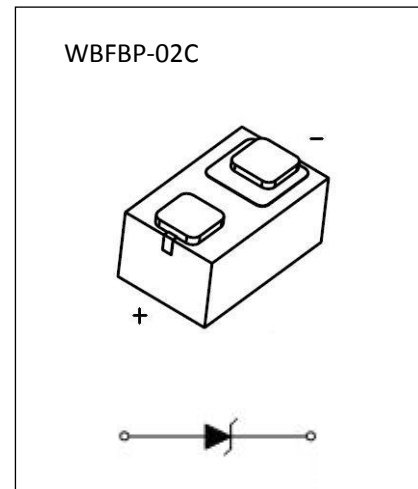

Maximum Ratings ($T_a=25^{\circ}\text{C}$ unless otherwise specified)

Characteristic	Symbol	Value	Unit
Forward Voltage (Note 1) @ $I_F=10\text{mA}$	V_F	0.9	V
Power Dissipation	P_D	100	mW
Thermal Resistance, Junction to Ambient Air	$R_{\theta JA}$	1250	$^{\circ}\text{C}/\text{W}$
Operation Junction and Storage Temperature Range	T_J, T_{STG}	-55 ~ +150	$^{\circ}\text{C}$

Notes:

- 1.Short duration pulse test used to minimize self-heating effect.

ELECTRICAL CHARACTERISTICS

$T_a=25^{\circ}\text{C}$ unless otherwise specified

Type Number	Marking Code	Zener Voltage Range (Note1)				Maximum Zener Impedance (Note 2)			Maximum Reverse Current (Note1)		Typical Temperature Coefficient @I _{ZTC}		Test Current I _{ZTC}
		V _Z @I _{ZT}			I _{ZT}	ZZT@I _{ZT}	ZZK@I _{ZK}	I _{ZK}	I _R	V _R	mV/°C		
		Nom(V)	Min(V)	Max(V)	mA	Ω		mA	uA	V	Min	Max	
DW52C2V4LED02	WX	2.4	2.2	2.6	5	100	600	1.0	50	1.0	-3.5	0	5
DW52C2V7LED02	W1	2.7	2.5	2.9	5	100	600	1.0	20	1.0	-3.5	0	5
DW52C3V0LED02	W2	3.0	2.8	3.2	5	95	600	1.0	10	1.0	-3.5	0	5
DW52C3V3LED02	W3	3.3	3.1	3.5	5	95	600	1.0	5	1.0	-3.5	0	5
DW52C3V6LED02	W4	3.6	3.4	3.8	5	90	600	1.0	5	1.0	-3.5	0	5
DW52C3V9LED02	W5	3.9	3.7	4.1	5	90	600	1.0	3	1.0	-3.5	0	5
DW52C4V3LED02	W6	4.3	4.0	4.6	5	90	600	1.0	3	1.0	-3.5	0	5
DW52C4V7LED02	W7	4.7	4.4	5.0	5	80	500	1.0	3	2.0	-3.5	0.2	5
DW52C5V1LED02	9Y	5.1	4.8	5.4	5	60	480	1.0	2	2.0	-2.7	1.2	5
DW52C5V6LED02	9A	5.6	5.2	6.0	5	40	400	1.0	1	2.0	-2.0	2.5	5
DW52C6V2LED02	9B	6.2	5.8	6.6	5	10	150	1.0	3	4.0	0.4	3.7	5
DW52C6V8LED02	9C	6.8	6.4	7.2	5	15	80	1.0	2	4.0	1.2	4.5	5
DW52C7V5LED02	9D	7.5	7.0	7.9	5	15	80	1.0	1	5.0	2.5	5.3	5
DW52C8V2LED02	9E	8.2	7.7	8.7	5	15	80	1.0	0.7	5.0	3.2	6.2	5
DW52C9V1LED02	9F	9.1	8.5	9.6	5	15	100	1.0	0.5	6.0	3.8	7.0	5
DW52C10LED02	9G	10	9.4	10.6	5	20	150	1.0	0.2	7.0	4.5	8.0	5
DW52C11LED02	9H	11	10.4	11.6	5	20	150	1.0	0.1	8.0	5.4	9.0	5
DW52C12LED02	9J	12	11.4	12.7	5	25	150	1.0	0.1	8.0	6.0	10.0	5
DW52C13LED02	9K	13	12.4	14.1	5	30	170	1.0	0.1	8.0	7.0	11.0	5
DW52C15LED02	9L	15	13.8	15.6	5	30	200	1.0	0.1	10.5	9.2	13.0	5
DW52C16LED02	9M	16	15.3	17.1	5	40	200	1.0	0.1	11.2	10.4	14.0	5
DW52C18LED02	9N	18	16.8	19.1	5	45	225	1.0	0.1	12.6	12.4	16.0	5
DW52C20LED02	9P	20	18.8	21.2	5	55	225	1.0	0.1	14.0	14.4	18.0	5
DW52C22LED02	9R	22	20.8	23.3	5	55	250	1.0	0.1	15.4	16.4	20.0	5
DW52C24LED02	9S	24	22.8	25.6	5	70	250	1.0	0.1	16.8	18.4	22.0	5
DW52C27LED02	9T	27	25.1	28.9	2	80	300	0.5	0.1	18.9	21.4	25.3	2
DW52C30LED02	9U	30	28.0	32.0	2	80	300	0.5	0.1	21.0	24.4	29.4	2
DW52C33LED02	9V	33	31.0	35.0	2	80	325	0.5	0.1	23.1	27.4	33.4	2
DW52C36LED02	9W	36	34.0	38.0	2	90	350	0.5	0.1	25.2	36.5	45.5	5
DW52C39LED02	9X	39	37.0	41.0	2	130	350	0.5	0.1	27.3	36.8	49.8	5
DW52C43LED02	9Z	43	40.0	46.0	5	100	700	1.0	0.1	32.0	10.0	12.0	5

Notes:

1.Short duration pulse test used to minimize self-heating effect.

2.f=1MHz

Typical Characteristics

Zener Characteristics (V_z Up to 10 V)

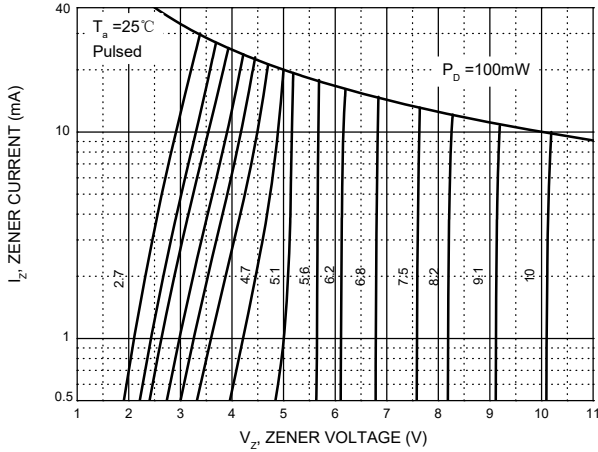

Zener Characteristics (11 V to 43 V)

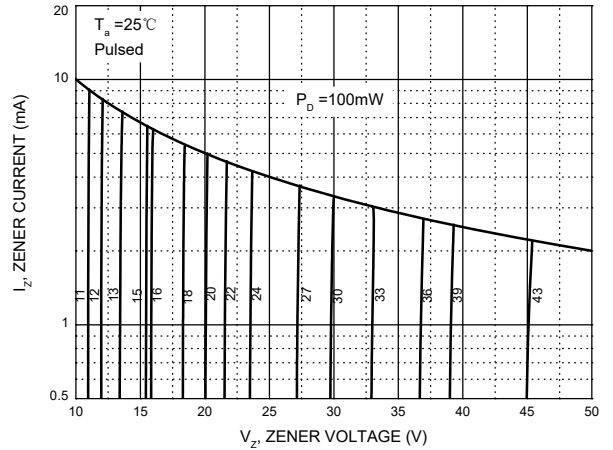

Temperature Coefficients

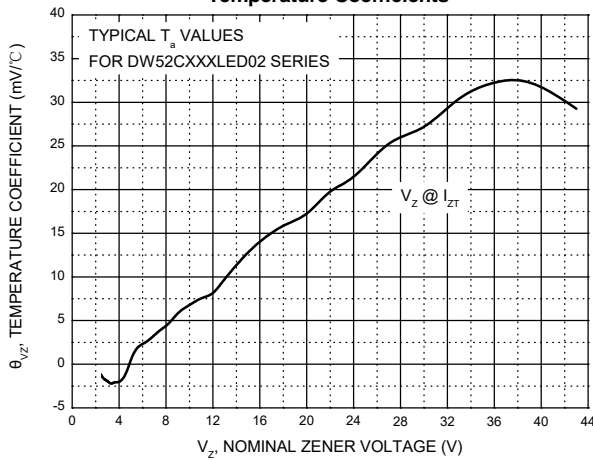

Typical Leakage Current

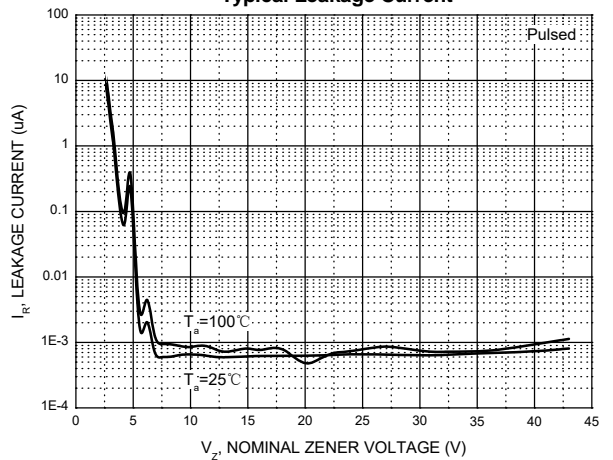

Typical Capacitance

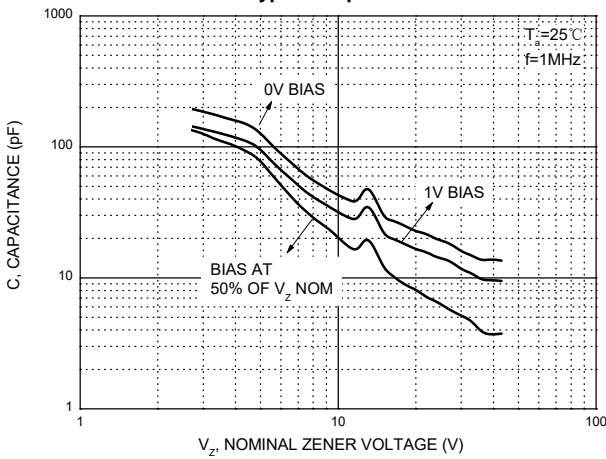

Effect of Zener Voltage on Zener Impedance

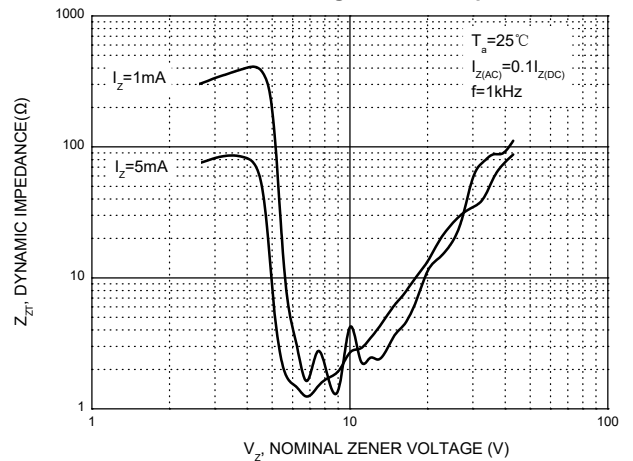

Power Derating Curve

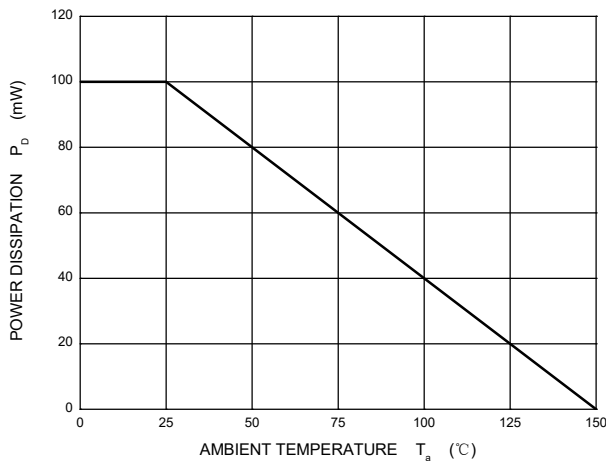

WBFBP-02C Package Outline Dimensions

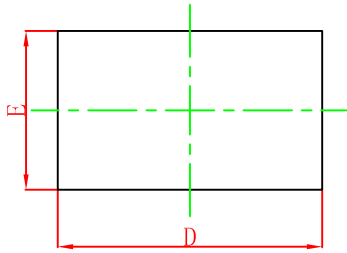

TOP VIEW

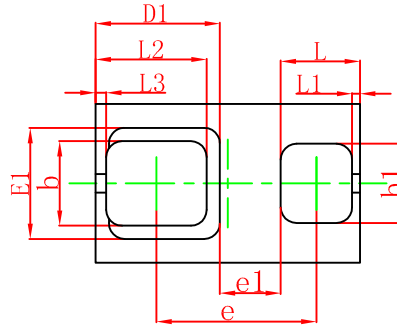

BOTTOM VIEW

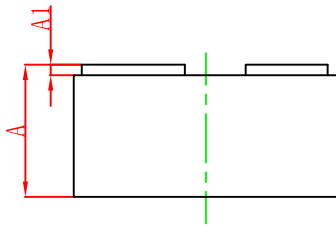

SIDE VIEW

Symbol	Dimensions In Millimeters		Dimensions In Inches	
	Min.	Max.	Min.	Max.
A	0.450	0.550	0.018	0.022
A1	0.010	0.100	0.000	0.004
D	0.950	1.050	0.037	0.041
E	0.550	0.650	0.022	0.026
D1	0.470REF.		0.019REF.	
E1	0.420REF.		0.017REF.	
b	0.270	0.370	0.011	0.015
b1	0.250	0.350	0.010	0.014
e	0.555	0.655	0.022	0.026
e1	0.230REF.		0.009REF.	
L	0.250	0.350	0.010	0.014
L1	0.030REF.		0.001REF.	
L2	0.370	0.470	0.015	0.019
L3	0.040REF.		0.002REF.	

WBFBP-02C Suggested Pad Layout

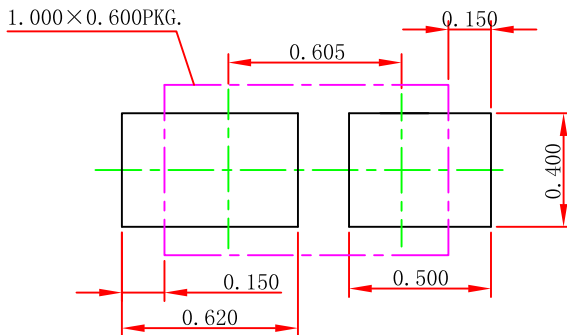

Note:

1. Controlling dimension: in millimeters.
2. General tolerance: ± 0.050 mm.
3. The pad layout is for reference purposes only.

NOTICE

JSCJ reserves the right to make modifications, enhancements, improvements, corrections or other changes without further notice to any product herein. JSCJ does not assume any liability arising out of the application or use of any product described herein.

DFN/FBP(1.0X0.6) Tape and Reel

DFN/FBP(1.0×0.6) Embossed Carrier Tape

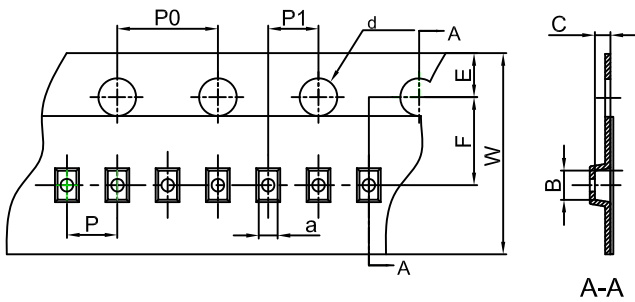

Packaging Description:

DFN/FBP(1.0×0.6) parts are shipped in tape. The carrier tape is made from a dissipative (carbon filled) polycarbonate resin. The cover tape is a multilayer film (Heat Activated Adhesive in nature) primarily composed of polyester film, adhesive layer, sealant, and anti-static sprayed agent. These reeled parts in standard option are shipped with 10,000 units per 7" or 17.8cm diameter reel. The reels are clear in color and is made of polystyrene plastic (anti-static coated).

Dimensions are in millimeter										
Pkg type	a	B	C	d	E	F	P0	P	P1	W
DFN/FBP(1.0×0.6)	0.66	1.15	0.66	∅1.50	1.75	3.50	4.00	2.00	2.00	8.00

DFN/FBP(1.0×0.6) Tape Leader and Trailer

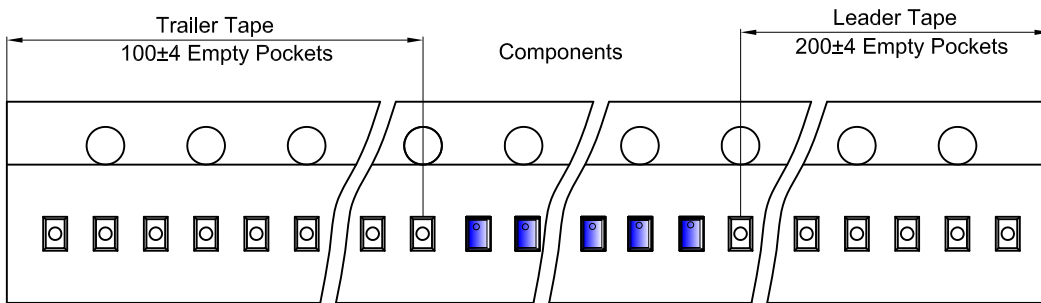

DFN/FBP(1.0×0.6) Reel

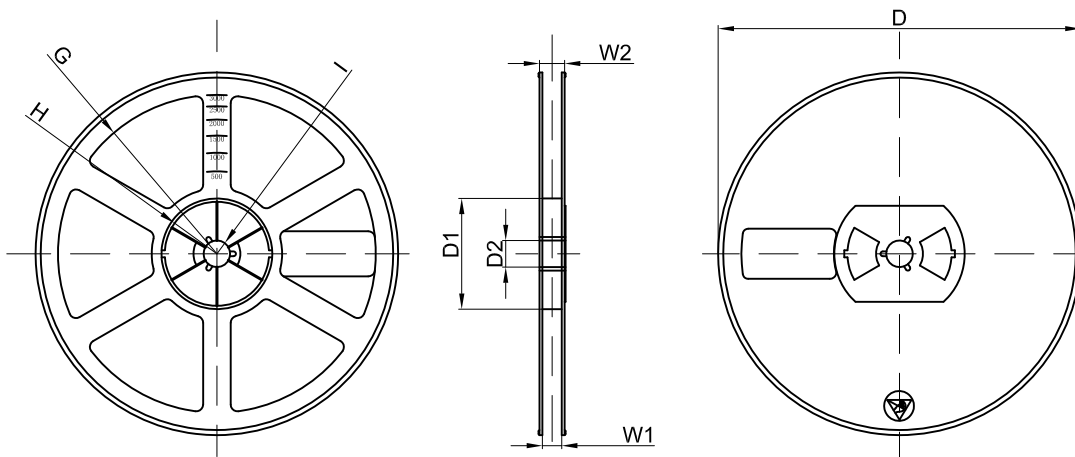

Dimensions are in millimeter								
Reel Option	D	D1	D2	G	H	I	W1	W2
7" Dia	∅178.00	54.40	13.00	R78.00	R25.60	R6.50	9.50	12.30

REEL	Reel Size	Box	Box Size(mm)	Carton	Carton Size(mm)	G.W.(kg)
10000 pcs	7 inch	150,000 pcs	203×203×195	600,000 pcs	438×438×220	