

DO-15 Plastic-Encapsulate Diodes

HER151 THRU HER158 High Efficient Rectifier Diodes

Features

- $I_{F(AV)}$ 1.5A
- V_{RRM} 50V-1000V
- High surge current capability
- Polarity: Color band denotes cathode

Applications

- Rectifier

Marking

- HER15X
X : From 1 To 8

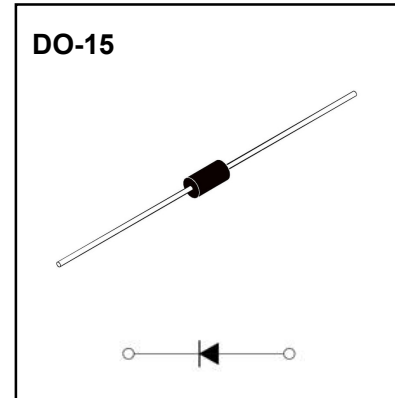

Limiting Values(Absolute Maximum Rating)

Item	Symbol	Unit	Test Conditions	HER15							
				1	2	3	4	5	6	7	8
Repetitive Peak Reverse Voltage	V_{RRM}	V		50	100	200	300	400	600	800	1000
Maximum RMS Voltage	V_{RMS}	V		35	70	140	210	280	420	560	700
Maximum DC Blocking Voltage	V_{DC}	V		50	100	200	300	400	600	800	1000
Average Forward Current	$I_{F(AV)}$	A	60Hz Half-sine wave, Resistance load, $T_L=50\text{ }^\circ\text{C}$	1.5							
Surge(Non-repetitive)Forward Current	I_{FSM}	A	60Hz Half-sine wave, 1 cycle, $T_a=25\text{ }^\circ\text{C}$	50							
Operation Junction and Storage Temperature Range	T_J, T_{STG}	$^\circ\text{C}$		-55 ~ +150							

Electrical Characteristics ($T=25\text{ }^\circ\text{C}$ Unless otherwise specified)

Item	Symbol	Unit	Test Condition	HER15							
				1	2	3	4	5	6	7	8
Maximum Peak Forward Voltage	V_F	V	$I_F=1.5A$	1.0		1.3		1.7			
Maximum Peak Reverse Current	I_{RRM1}	μA	$V_{RM}=V_{RRM}$	$T_J=25\text{ }^\circ\text{C}$							
	I_{RRM2}			$T_J=125\text{ }^\circ\text{C}$							
Maximum reverse recovery time	t_{rr}	ns	$I_F=0.5A, I_R=1.0A, I_{rr}=0.25A$	50					75		
Typical junction capacitance	C_J	pF	Measured at 1MHz and applied reverse voltage of 4.0V D.C.	30					20		
Typical Thermal Resistance	$R_{\theta J-A}$	$^\circ\text{C/W}$	Between junction and ambient	50							
	$R_{\theta J-L}$		Between junction and lead	25							

Notes:

Thermal resistance from junction to ambient at 0.375"(9.5mm)lead length,P.C.B. mounted

Typical Characteristics

FIG.1: FORWARD CURRENT DERATING CURVE

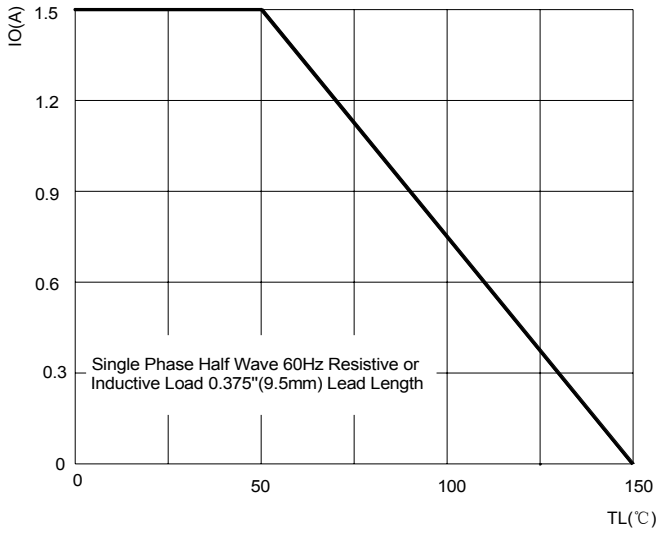

FIG.2: MAXIMUM NON-REPETITIVE FORWARD URGE CURRENT

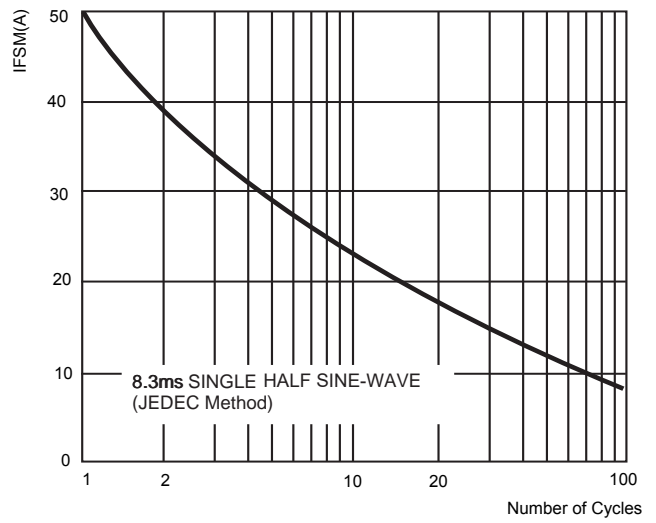

FIG.3: TYPICAL FORWARD CHARACTERISTICS

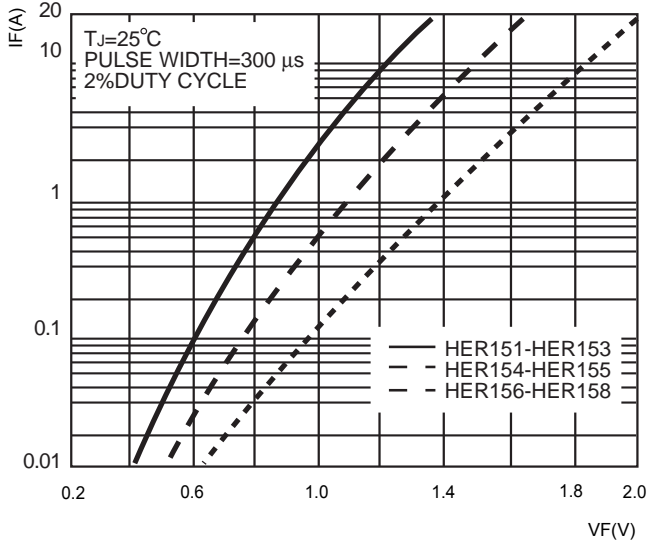

FIG.4: TYPICAL REVERSE CHARACTERISTICS

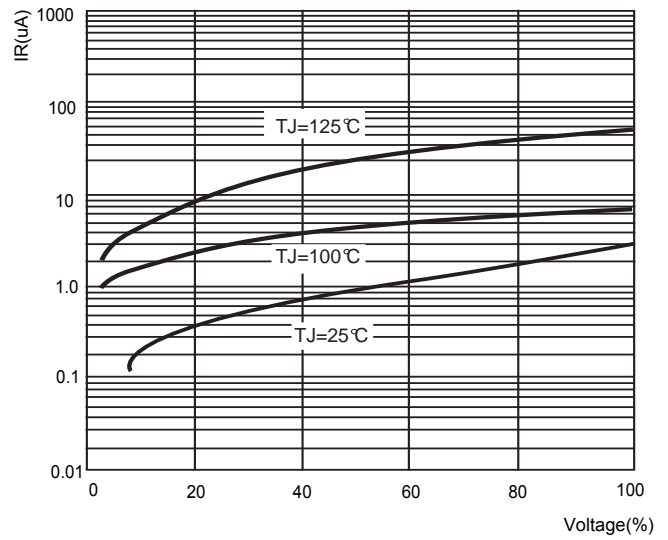
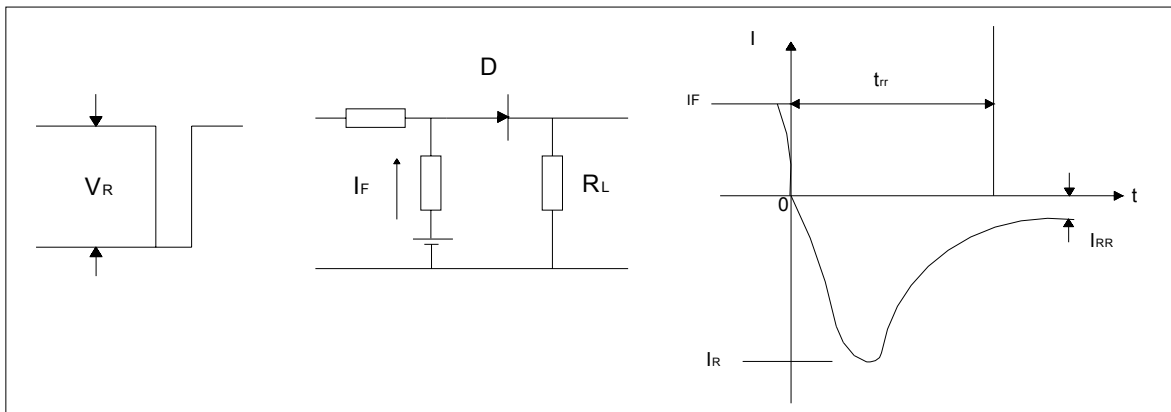
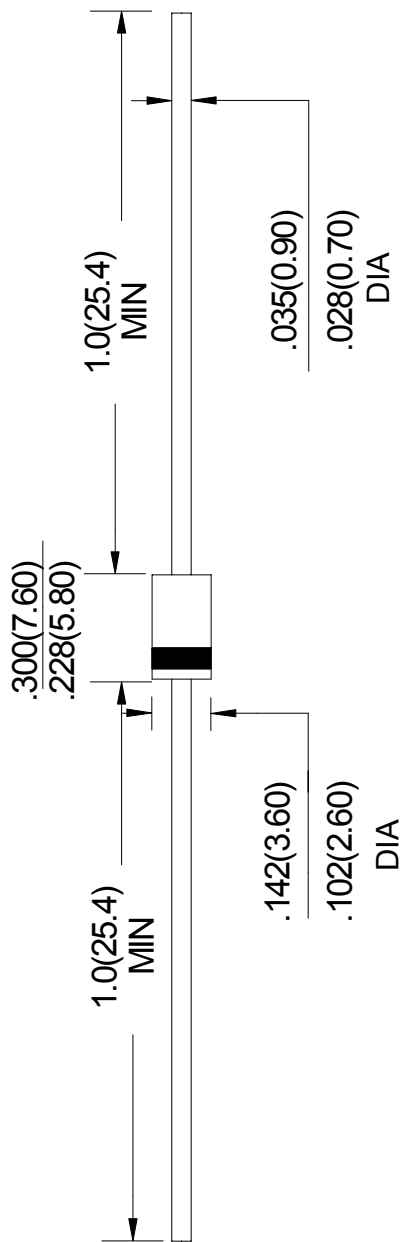

FIG.5: Diagram of circuit and Testing wave form of reverse recovery time



DO-15 Package Outline Dimensions



Unit: in inches (millimeters)

NOTICE

JSCJ reserves the right to make modifications, enhancements, improvements, corrections or other changes without further notice to any product herein. JSCJ does not assume any liability arising out of the application or use of any product described herein.

Ammo Box Packaging Specifications For Axial Lead Rectifiers

Axial lead devices are packed in accordance with EIA standard RS-296-D and specifications given below

COMPONENT OUTLINE	COMPONENT PITCH A	INNER TAPE PITCH B	CUMULATIVE PITCH TOLERANCE
	$\pm 0.5\text{mm}(.020'')$	$+0.5\text{mm}(.020'')$	
R-1	5.0mm	26.0mm	2.0mm/20pitch
R-1	5.0mm	52.4mm	2.0mm/10pitch
A-405	5.0mm	26.0mm	2.0mm/20pitch
A-405	5.0mm	52.4mm	2.0mm/10pitch
DO-34/DO-35	5.0mm	26.0mm	2.0mm/20pitch
DO-34/DO-35	5.0mm	52.4mm	2.0mm/10pitch
DO-41	5.0mm	26.0mm	2.0mm/20pitch
DO-41	5.0mm	52.4mm	2.0mm/10pitch
DO-15	5.0mm	52.4mm	2.0mm/10pitch
DO-27	10.0mm	52.4mm	2.0mm/10pitch
R-6	10.0mm	52.4mm	2.0mm/10pitch

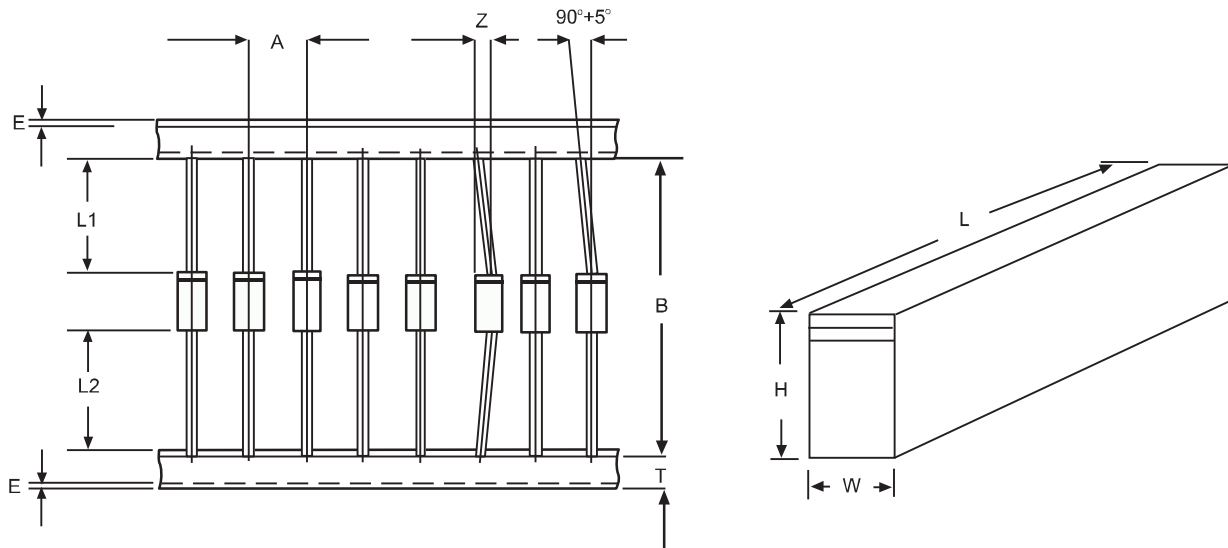

ITEM	SYMBOL	SPECIFICATIONS(mm)	SPECIFICATIONS(inch)
Component alignment	Z	1.2max	0.048max
Tape width	T	6.0 ± 0.4	0.236 ± 0.016
Exposed adhesive	E	0.8max	0.032max
Body eccentricity	IL1-L2I	1.0max	0.040max
Box length	L	255.0 ± 5.0	10.04 ± 0.197
Box width	W	78.0 ± 5.0	3.07 ± 0.197
Box height	H	150.0 ± 5.0	5.91 ± 0.197

NOTE: Each component lead shall be sandwiched between tapes for A minimum of 3.2mm(0.126'')