



## JRC4558 Dual Channel Operational Amplifier

### 1 Introduction

JRC4558 is a low noise, high gain, dual channel operational amplifier, which is internally compensated and built on a single silicon chip by using advanced epitaxial technology. It is suitable for single power supply with wide power supply voltage range, and also suitable for dual power supply working mode. Under the recommended working conditions, the power supply current is independent of the power supply voltage. The application range of JRC4558 includes active filter, compensation amplifier, audio preamplifier, equalization amplifier, and various linear amplifiers in electronic instruments.

### 2 Available Package

PART NUMBER	PACKAGE
JRC4558	SOP-8

**Note:** For more detailed packaging information, see the part *Pin Configuration and Function* and the part *Mechanical Information*.

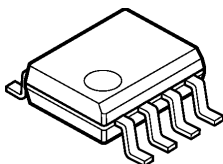

SOP-8

Figure 2-1. JRC4558 Package

### 3 Features

- Internal Frequency Compensation
- Operating Voltage:  $\pm 4 \sim \pm 18V$
- High DC Voltage Gain: 100dB (Typ.)
- High Input Impedance:  $5M\Omega$  (Typ.)
- Unit Gain Bandwidth: 3.5MHz
- Low Input Bias Current
- Low Input Offset Voltage and Current
- Norm of Power Supply
- Large Swing of Output Voltage:  
 $0 \sim (V_{CC} - 1.5V)$

### 4 Applications

- Active Filter
- Compensation Amplifier
- Audio Preamplifier
- Electronic Instruments

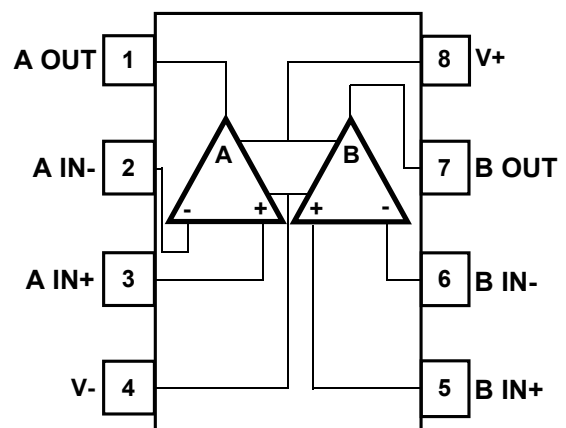

Figure 3-1. Logic Function Diagram

## 5 Pin Configuration and Marking Information

### 5.1 Pin Configuration and Function

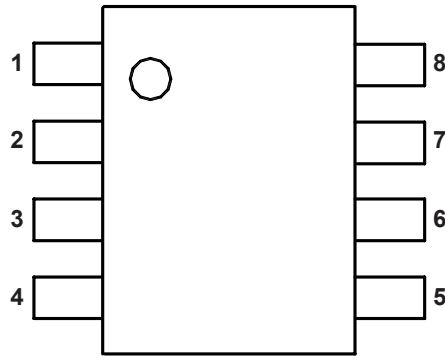

Figure 5-1. SOP-8 Package Top View

PIN NAME	JRC4558	I / O	DESCRIPTION
	SOP-8		
OUT A	1	O	Output of operational amplifier A.
A IN-	2	I	Negative input of of operational amplifier A.
A IN+	3	I	Positive input of of operational amplifier A.
V-	4	Power-	Negative power supply.
B IN+	5	I	Positive input of of operational amplifier B.
B IN-	6	I	Negative input of of operational amplifier B.
B OUT	7	O	Output of operational amplifier B.
V+	8	Power+	Positive power supply.

### 5.2 Marking Information



## 6 Specifications

### 6.1 Absolute Maximum Ratings<sup>(1)</sup>

(over operating free-air temperature range, unless otherwise specified)

CHARACTERISTIC			SYMBOL	VALUE	UNIT
Power supply voltage <sup>(2)</sup>			V+ / V-	±18V	V
Input pin voltage <sup>(2)</sup>			V <sub>IN</sub>	±15V	
Differential Input Voltage <sup>(2)</sup>			V <sub>IN DIF</sub>	±18V	
Maximum power dissipation	JRC4558	SOP-8	P <sub>D Max</sub>	Internally Limited <sup>(3)</sup>	W
Maximum junction temperature			T <sub>J Max</sub>	150	°C
Storage temperature			T <sub>stg</sub>	-65 ~ 150	°C
Soldering temperature & time			T <sub>solder</sub>	260°C, 10s	-

(1) Stresses greater than those listed under *Absolute Maximum Ratings* may cause permanent damage to the device. These are stress ratings only, and functional of the device at these or any other conditions beyond those indicated under *Recommended Operating Conditions* is not implied. Exposure to absolute maximum ratings for extended periods may affect device reliability.

(2) All voltages are with respect to network ground terminal.

(3) Refer to *Thermal Information* for details.

### 6.2 Recommended Operating Conditions<sup>(4)</sup>

PARAMETER	SYMBOL	MIN.	NOM.	MAX.	UNIT
Operating power supply voltage	V+ / V-	±4		±18	V
Operating junction temperature	T <sub>J</sub>	-40	-	125	°C
Operating ambient temperature	T <sub>A</sub>	-40	-	85 <sup>(5)</sup>	°C

(4) JSCJ recommends that the operating conditions of the devices used by the user should not exceed the rated values in the *Recommended Operating Conditions* to ensure the stability of the normal operation of the equipment and the reliability of long-term operation. Although working beyond the rated range of the recommended conditions does not mean that the device will fail, it is still necessary to fully evaluate the possible risks caused by working beyond the rated range of the recommended conditions.

(5) JSCJ recommends that the operating junction temperature (OP T<sub>J</sub>) of the device should not exceed the rated value of the recommended operating conditions.

## 6 Specifications

### 6.3 Thermal Information

THERMAL METRIC <sup>(6)</sup>	SYMBOL	JRC4558	UNIT
		SOP-8	
Junction-to-ambient thermal resistance	$R_{\theta JA}$	150.0	°C/W
Reference maximum power dissipation for continuous operation	$P_{D Ref}$	0.83	W

(6) All numbers are typical, and apply for packages soldered directly onto a PCB board in still air.

### 6.4 Electrical Characteristics

JRC4558 ( $T_A = 25^\circ\text{C}$ , unless otherwise specified)

CHARACTERISTIC		SYMBOL	TEST CONDITIONS	MIN.	TYP. <sup>(7)</sup>	MAX.	UNIT
Power Supply Current		$I_{CC}$	$R_L = \infty$	-	3.5	5.7	mA
Input Offset Voltage		$V_{IO}$	$R_S < 10\text{k}\Omega$	-	2.0	6	mV
Input Offset Current		$I_{IO}$	$V_{CM} = 0\text{V}$	-	5.0	200	nA
Input Bias Current		$I_{BIAS}$	$V_{CM} = 0\text{V}$	-	30	500	nA
Input Current	Source	$I_{SOURCE}$	-	40	-	80	mA
	Sink	$I_{SINK}$	-	-80	-	-50	
Input Common Mode Voltage		$V_{IN(R)}$	-	-	$\pm 12$	$\pm 13$	V
Large Signal Voltage Gain		$G_V$	$V_{OUT P-P} = \pm 10\text{V}, R_L < 2\text{k}\Omega$	80	100	-	dB
Output Voltage Swing		$V_{OUT P-P}$	$R_L > 10\text{k}\Omega$	$\pm 12$	$\pm 14$	-	V
			$R_L > 2\text{k}\Omega$	$\pm 10$	$\pm 13$	-	
Common Mode Rejection Ratio		CMRR	$R_S < 10\text{k}\Omega$	70	95	-	dB
Power Supply Rejection Ratio		PSRR	$R_S < 10\text{k}\Omega$	75	100	-	dB
Conversion Rate		SR	-	-	1.5	-	V / $\mu\text{s}$
Gain Bandwidth Product		GBP	-	-	3.5	-	MHz

**Note:**

(7) Typical numbers are at 25°C and represent the most likely norm.

## 6 Specifications

### 6.5 Typical Characteristics

JRC4558 ( $T_A = 25^\circ\text{C}$ , unless otherwise specified)

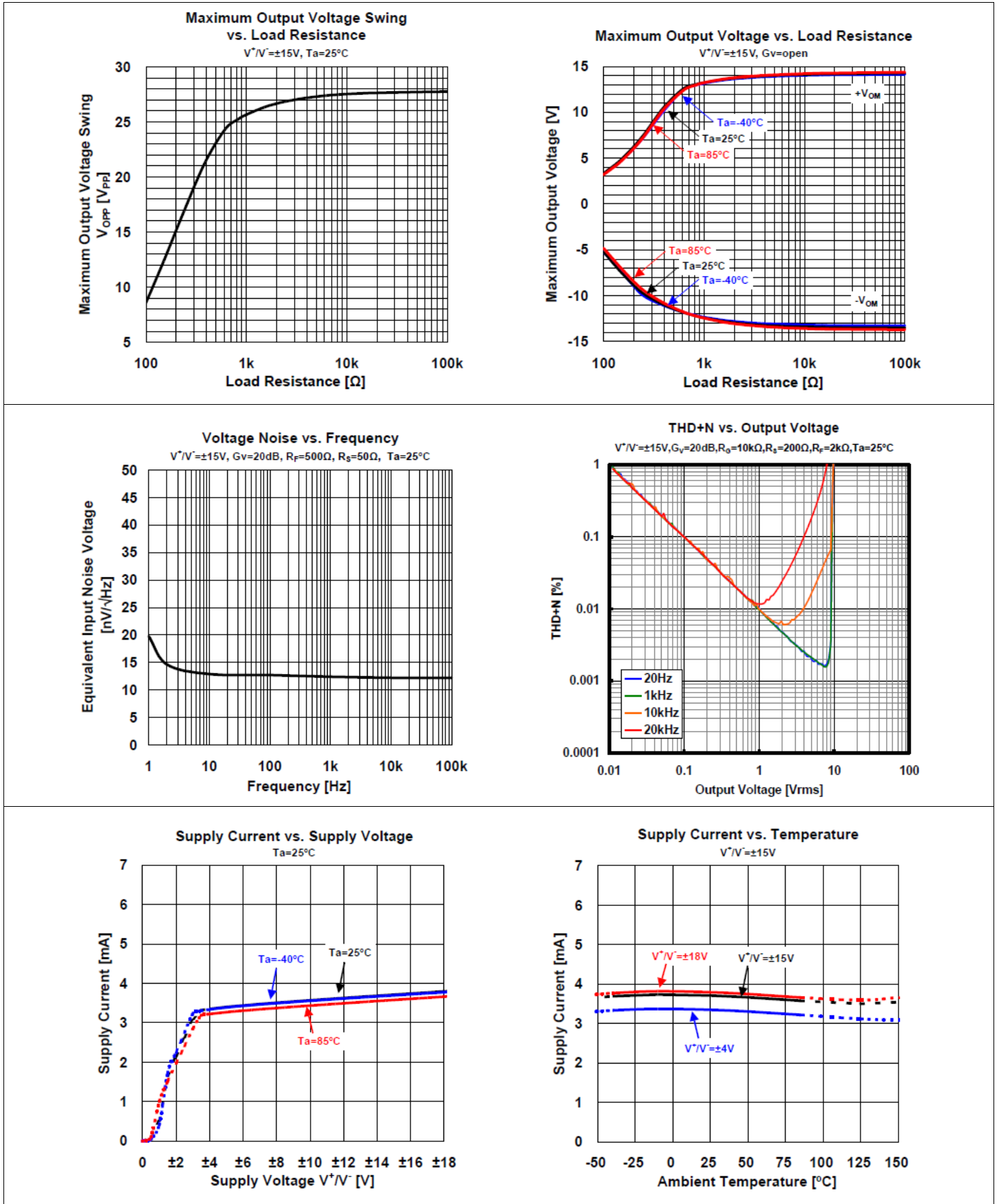

## 6 Specifications

### 6.5 Typical Characteristics (continued)

JRC4558 ( $T_A = 25^\circ\text{C}$ , unless otherwise specified)

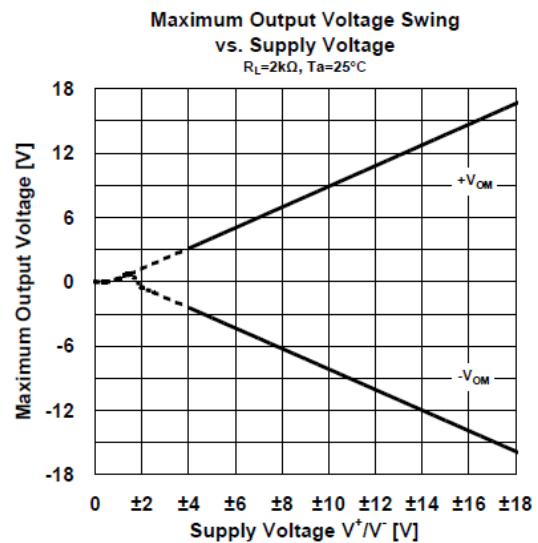
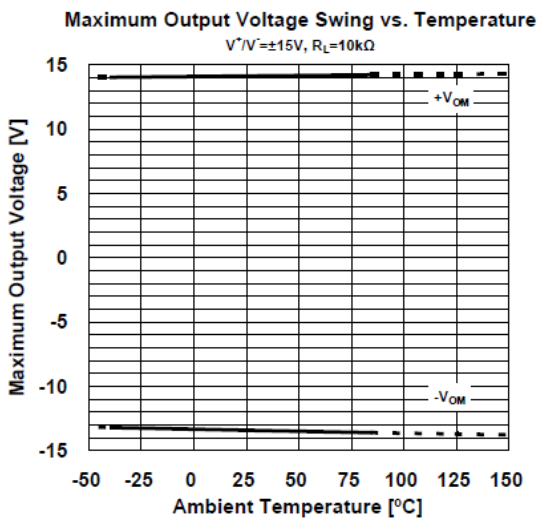
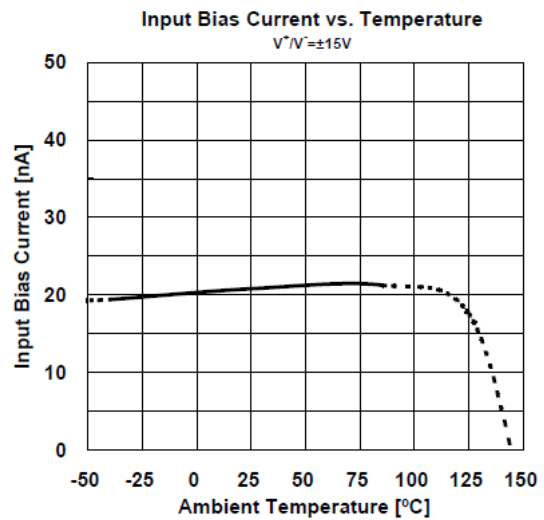
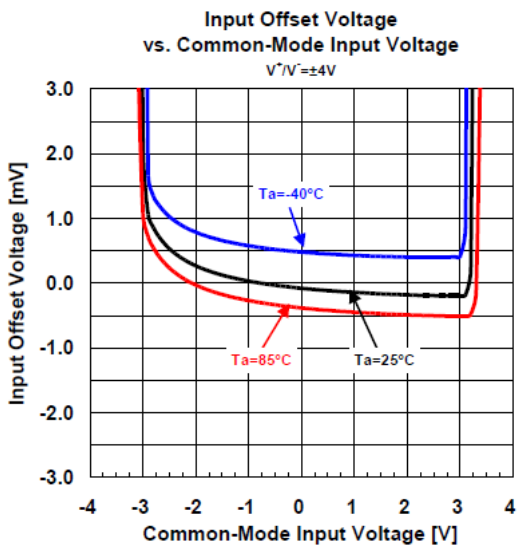
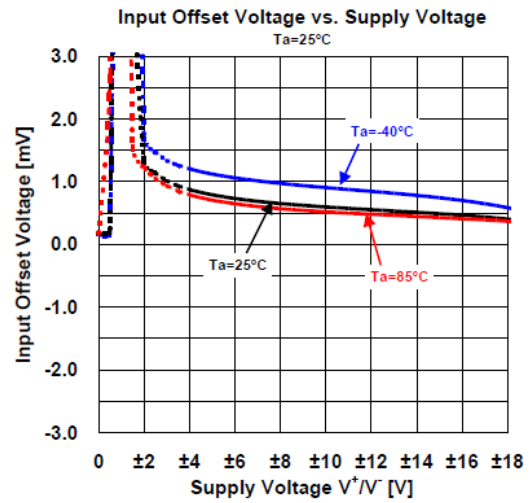
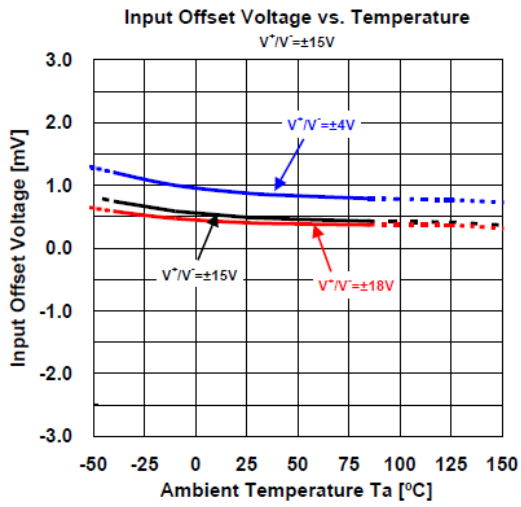

## 6 Specifications

### 6.5 Typical Characteristics (continued)

JRC4558 ( $T_A = 25^\circ\text{C}$ , unless otherwise specified)

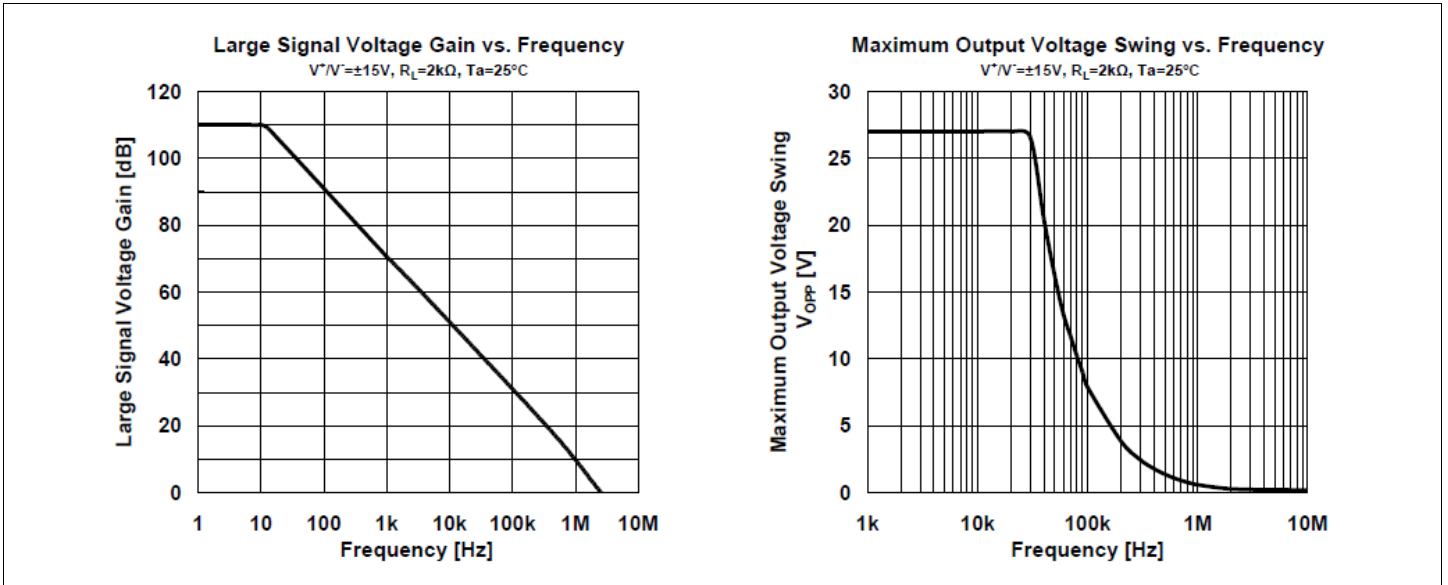

### 6.6 Representative Schematic Diagram

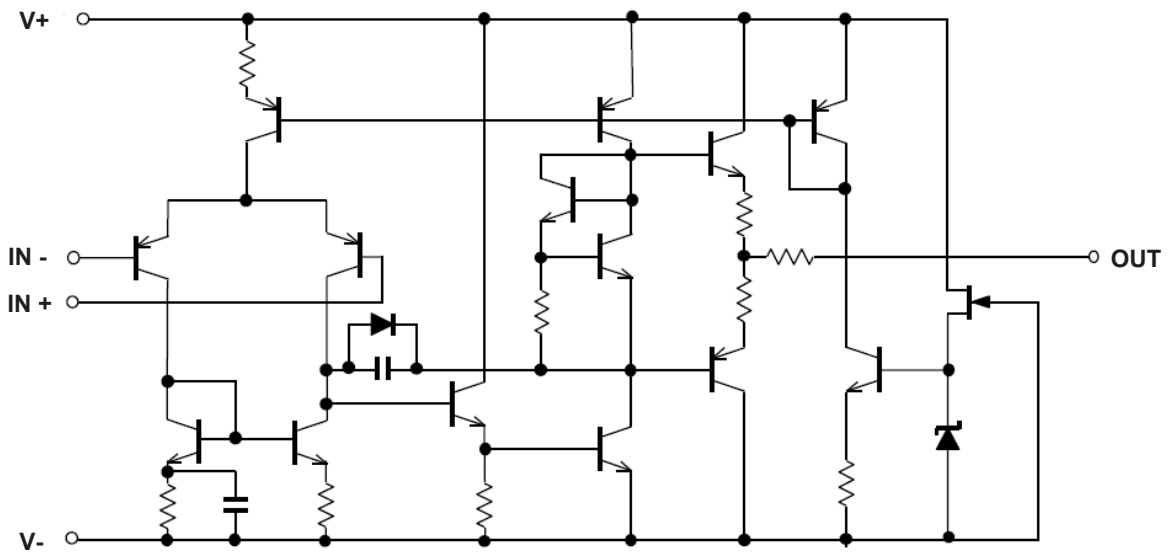

(for single operational amplifier)

7 Mechanical Information

SOP-8 Package Mechanical Information

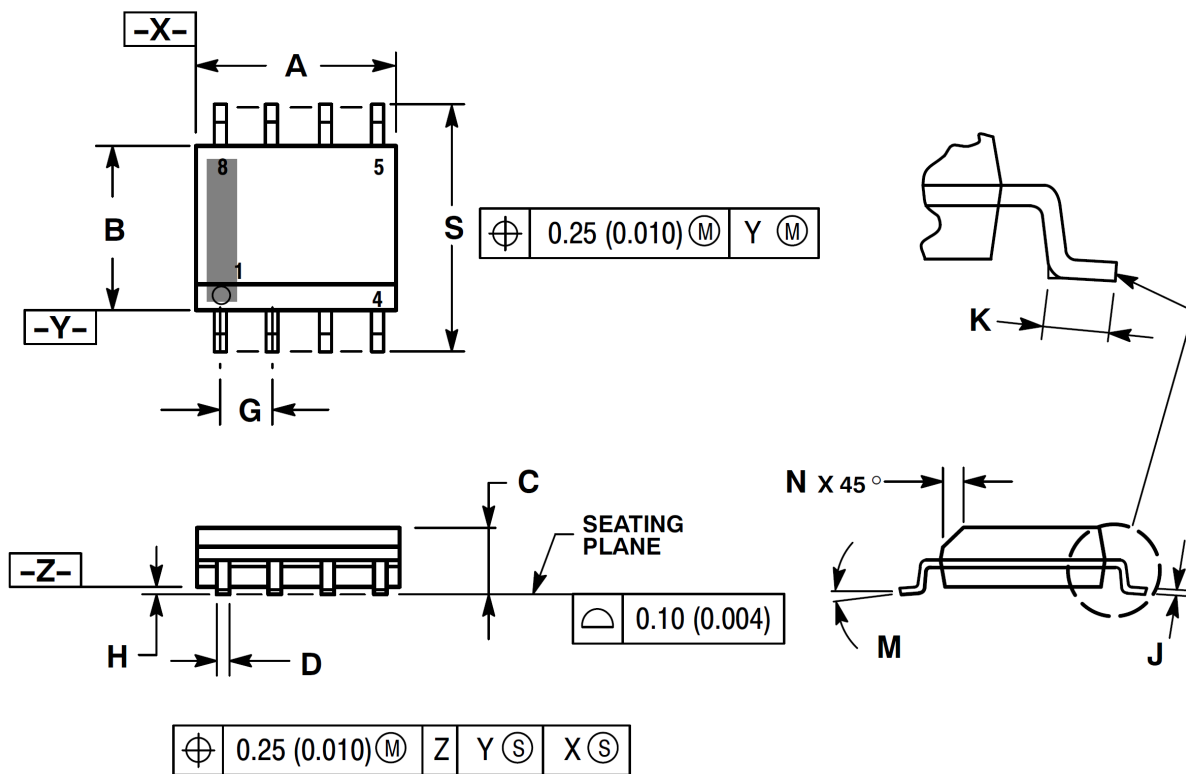

SYMBOL	DIMENSIONS IN MILLIMETERS			DIMENSIONS IN INCHES		
	MIN	NOM	MAX	MIN	NOM	MAX
A	4.800	-	5.000	0.189	-	0.197
B	3.800	-	4.000	0.150	-	0.157
C	1.350	-	1.750	0.053	-	0.069
D	0.330	-	0.510	0.013	-	0.020
G	1.270 Bsc.			0.050 Bsc.		
H	0.100	-	0.250	0.004	-	0.010
J	0.190	-	0.250	0.007	-	0.010
K	0.400	-	1.270	0.016	-	0.050
M	0°	-	8°	0°	-	8°
N	0.250	-	0.500	0.010	-	0.020
S	5.800	-	6.200	0.228	-	0.244

## 8 Notes and Revision History

### 8.1 Associated Product Family and Others

To view other products of the same type or IC products of other types, please click the official website of JSCJ -- <https://www.jscj-elec.com> for more details.

### 8.2 Notes

#### Electrostatic Discharge Caution



This IC may be damaged by ESD. Relevant personnel shall comply with correct installation and use specifications to avoid ESD damage to the IC. If appropriate measures are not taken to prevent ESD damage, the hazards caused by ESD include but are not limited to degradation of integrated circuit performance or complete damage of integrated circuit. For some precision integrated circuits, a very small parameter change may cause the whole device to be inconsistent with its published specifications.

### 8.3 Revision History

August 2022, released JRC4558 rev - 1.0.

# DISCLAIMER

## **IMPORTANT NOTICE, PLEASE READ CAREFULLY**

The information in this data sheet is intended to describe the operation and characteristics of our products. JSCJ has the right to make any modification, enhancement, improvement, correction or other changes to any content in this data sheet, including but not limited to specification parameters, circuit design and application information, without prior notice.

Any person who purchases or uses JSCJ products for design shall: 1. Select products suitable for circuit application and design; 2. Design, verify and test the rationality of circuit design; 3. Procedures to ensure that the design complies with relevant laws and regulations and the requirements of such laws and regulations. JSCJ makes no warranty or representation as to the accuracy or completeness of the information contained in this data sheet and assumes no responsibility for the application or use of any of the products described in this data sheet.

Without the written consent of JSCJ, this product shall not be used in occasions requiring high quality or high reliability, including but not limited to the following occasions: medical equipment, military facilities and aerospace. JSCJ shall not be responsible for casualties or property losses caused by abnormal use or application of this product.

Official Website: [www.jscj-elec.com](http://www.jscj-elec.com)

Copyright © JIANGSU CHANGJING ELECTRONICS TECHNOLOGY CO., LTD.