

## LM317C Adjustable Three-Terminal Regulator

### 1 Introduction

The LM317C is a three terminal positive voltage regulator with maximum 1.5A current output and adjustable output. The voltage regulator is very easy to use, which only needs two external resistors to set the output voltage, and the output voltage can be set in the range of 1.25V to 37V. In addition, the LM317C is also designed to integrate internal current limiting, thermal shutdown and safe working area compensation, which makes it relatively difficult to damage and basically prevent the burning of circuit fuses.

The LM317C serves a variety of applications, including local voltage stabilization and card voltage stabilization. It can also be used to make a programmable voltage regulator, or as a precision current regulator by connecting a fixed resistance between the adjustment point and the output.

### 2 Available Packages

PART NUMBER	PACKAGE
LM317C	SOT-223
	TO-220-3L
	TO-252-2L
	TO-263-2L

### 3 Features

- The output current exceeds 1.5A
- The output is adjustable from 1.25V to 37V
- Internal thermal overload protection
- Temperature independent internal short circuit current limit
- Output transistor safe working area compensation
- Commonly used TO-252 package, as well as other forms of three pin package
- Avoid preparing multiple fixed voltages

### 4 Applications

- Ethernet Switch, Public Server, Private Switch (PBX)
- Base Station
- Desktop Computer
- IP Telephone: Wired and Wireless
- Motor Control
- Refrigerator, Air Conditioner, Washing Machine
- Security Camera, Digital Sign
- Signal or Waveform Generator
- Substation Control, Power Quality Meter

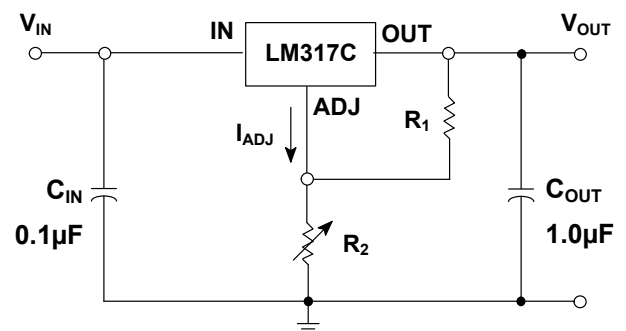

Typical Application Circuits

Please carefully read the notice at the end of this data sheet about product use, data sheet changes and important statements.

**5 Orderable Information**

MODEL	DEVICE	PACKAGE	OP T <sub>J</sub>	ECO PLAN	MSL	PACKING OPTION	SORT
LM317C	-	SOT-223	-40 ~ 125°C	RoHS & Green	Level 3 168 HR	Tape and Reel 2500 Units / Reel	Active
	-	TO-220-3L	-40 ~ 125°C	RoHS & Green	N / A for Pkg Type	Tube 50 Units / Rail	Active
	-	TO-252-2L	-40 ~ 125°C	RoHS & Green	Level 3 168 HR	Tape and Reel 2500 Units / Reel	Active
	-	TO-263-2L	-40 ~ 125°C	RoHS & Green	N / A for Pkg Type	Tape and Reel 800 Units / Reel	Active
Others	-	-	-	-	-	-	Customized

**Note:**

**ECO PLAN:** For the RoHS and Green certification standards of this product, please refer to the official report provided by JSCJ.

**MSL:** Moisture Sensitivity Level. Determined according to JEDEC industry standard classification.

**SORT:** Specifically defined as follows:

Active: Recommended for new products;

Customized: Products manufactured to meet the specific needs of customers;

Preview: The device has been released and has not been fully mass produced. The sample may or may not be available;

NoRD: It is not recommended to use the device for new design. The device is only produced for the needs of existing customers;

Obsolete: The device has been discontinued.

## 6 Pin Configuration and Marking Information

### 6.1 Pin Configuration and Function

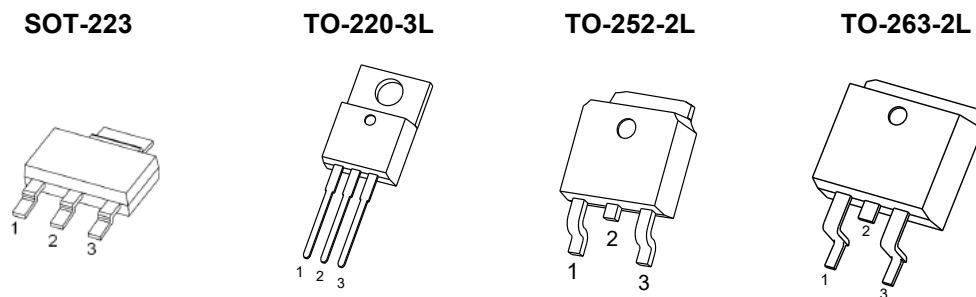
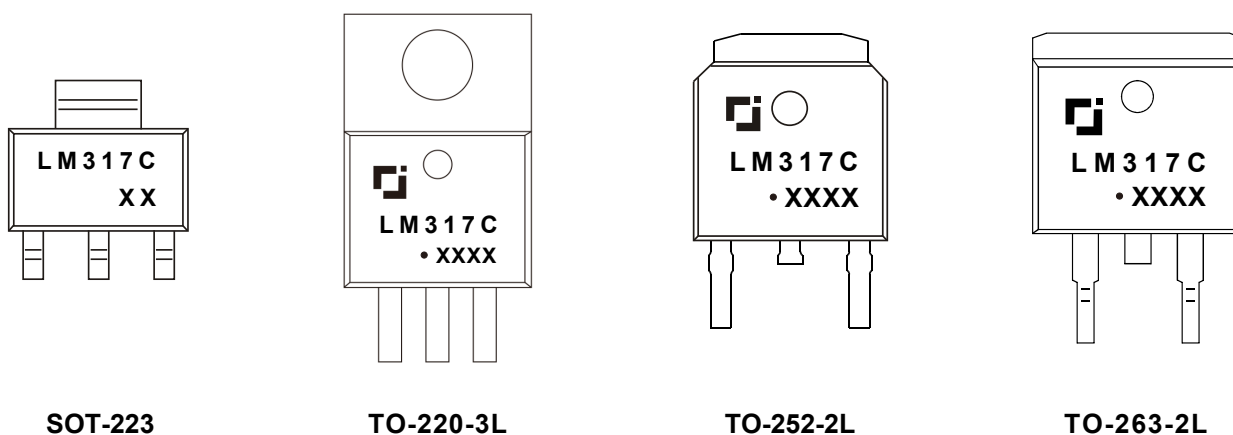

Figure 6-1. Package Top View

PIN NAME	LM317C				I / O	DESCRIPTION
	SOT-223	TO-220-3L	TO-252-2L	TO-263-2L		
IN	3	3	3	3	I	Supply input pin.
ADJ	1	1	1	1	-	Adjustment pin. Connect to a resistor divider to set $V_{OUT}$ .
OUT	2	2	2	2	O	Voltage output pin.

### 6.2 Marking Information



"LM317C" : Device number.

"XX" & "XXXX" : Code. Indicates weekly record information of production.

" . " : Green molding compound device.

## 7 Specifications

### 7.1 Absolute Maximum Ratings

(over operating free-air temperature range, unless otherwise specified)<sup>(1)</sup>

CHARACTERISTIC		SYMBOL	VALUE	UNITS
Maximum Input-to-output differential voltage		$V_{IN} - V_{OUT}$	40	V
Programmable output voltage range		$V_{OUT}$	37	
Maximum power dissipation	LM317C	SOT-223	Internally Limited <sup>(2)</sup>	W
		TO-220-3L		
		TO-252-2L		
		TO-263-2L		
Maximum junction temperature		$T_{J Max}$	150	°C
Storage temperature		$T_{stg}$	-65 ~ 150	°C
Soldering temperature & time		$T_{solder}$	260°C, 10s	-

(1) Stresses beyond those listed under *Absolute Maximum Ratings* may cause permanent damage to the device. These are stress ratings only, which do not imply functional operation of the device at these or any other conditions beyond those indicated under *Recommended Operating Conditions*. Exposure to absolute-maximum rated conditions for extended periods may affect device reliability.

(2) Refer to *Thermal Information* for details.

### 7.2 Recommended Operating Conditions

PARAMETER	SYMBOL	MIN.	NOM.	MAX.	UNIT
Input-to-output differential voltage	$V_{IN} - V_{OUT}$	3.0	-	40	V
Programmable output voltage	$V_{OUT}$	1.25	-	37	V
Output current range	$I_{OUT}$	0.01	-	1.5	A
Operating junction temperature	$T_J$	-40	-	125	°C
Operating ambient temperature	$T_A$	-	-(3)	-	°C

(3) It is necessary to ensure that the operating junction temperature of the device does not exceed the rated value of the recommended operating conditions when using the device for design.

## 7 Specifications

### 7.3 ESD Ratings

ESD RATINGS		SYMBOL	VALUE	UNIT
Electrostatic discharge <sup>(4)</sup>	Human body model	V <sub>ESD-HBM</sub>	2000	V
	Machine model	V <sub>ESD-MM</sub>	200	

(4) ESD testing is conducted in accordance with the relevant specifications formulated by the Joint Electronic Equipment Engineering Commission (JEDEC). The human body mode (HBM) electrostatic discharge test is based on the JESD22-114D test standard, using a 100pF capacitor and discharging to each pin of the device through a resistance of 1.5kΩ. The electrostatic discharge test in mechanical mode (MM) is based on the JESD22-A115-A test standard and uses a 200pF capacitor to discharge directly to each pin of the device.

### 7.4 Thermal Information

THERMAL METRIC <sup>(5)</sup>	SYMBOL	LM317C		UNIT
Junction-to-ambient thermal resistance	R <sub>θJA</sub>	<b>SOT-223</b>	<b>TO-220-3L</b>	°C/W
		100.0	66.7	
		<b>TO-252-2L</b>	<b>TO-263-2L</b>	
		80.0	62.5	
Junction-to-case thermal resistance	R <sub>θJC</sub>	<b>SOT-223</b>	<b>TO-220-3L</b>	°C/W
		27.0	5.5	
		<b>TO-252-2L</b>	<b>TO-263-2L</b>	
		14.5	5.5	
Maximum power dissipation for continuous operation	P <sub>D Ref</sub>	<b>SOT-223</b>	<b>TO-220-3L</b>	W
		1.00	1.50	
		<b>TO-252-2L</b>	<b>TO-263-2L</b>	
		1.25	1.60	

(5) Thermal metric is measured in still air with T<sub>A</sub> = 25°C and installed on a 1 in<sup>2</sup> FR-4 board covered with 2 ounces of copper.

## 7 Specifications

### 7.5 Electrical Characteristics

LM317C ( $V_{IN} - V_{OUT} = 5.0V$ ,  $I_{OUT} = 500mA$ ,  $C_{IN} = 1\mu F$ ,  $C_{OUT} = 1\mu F$ , unless otherwise specified)

CHARACTERISTIC	SYMBOL	TEST CONDITIONS <sup>(6)</sup>		MIN.	TYP. <sup>(7)</sup>	MAX.	UNIT	
Line regulation	LNR <sup>(8)</sup>	$V_{IN} - V_{OUT} = 3.0$ to $40V$		$T_J = 25^\circ C$	-	0.01	0.04	%V
				$T_J = 0$ to $125^\circ C$	-	0.02	0.07	
Load regulation	LDR	$I_{OUT} = 10$ to $1500mA$	$V_{OUT} < 5.0V$	$T_J = 25^\circ C$	-	5.0	25	mV
				$T_J = 0$ to $125^\circ C$	-	20	70	
			$V_{OUT} \geq 5.0V$	$T_J = 25^\circ C$	-	0.1	0.5	%· $V_{OUT}$
				$T_J = 0$ to $125^\circ C$	-	0.3	1.5	
ADJUST terminal current	$I_{ADJ}$	-		$T_J = 25^\circ C$	-	50	100	$\mu A$
Change in ADJUST terminal current	$\Delta I_{ADJ}$	$V_{IN} - V_{OUT} = 2.5$ to $40V$ $I_{OUT} = 10$ to $1500mA$		$T_J = 25^\circ C$	-	0.2	5.0	$\mu A$
Reference voltage	$V_{REF}$	$V_{IN} - V_{OUT} = 3.0$ to $40V$ $I_{OUT} = 10$ to $1500mA$		$T_J = 25^\circ C$	1.20	1.25	1.30	V
Line regulation of reference voltage	LNR $V_{REF}$	$V_{IN} - V_{OUT} = 3.0$ to $40V$		$T_J = 25^\circ C$	-	0.02	0.07	%V
Load regulation of reference voltage	LDR $V_{REF}$	$I_{OUT} = 10$ to $1500mA$	$V_{OUT} < 5.0V$	$T_J = 25^\circ C$	-	20	70	mV
			$V_{OUT} \geq 5.0V$	$T_J = 25^\circ C$	-	0.3	1.5	%· $V_{OUT}$
Output voltage temperature stability	$\Delta V_{OUT} / V_{OUT}$	-		$T_J = 0$ to $125^\circ C$	-	1.0	-	%
Minimum load current to maintain regulation	$I_{OUT MIN}$	$V_{IN} - V_{OUT} = 40V$		$T_J = 0$ to $125^\circ C$	-	3.5	10	mA
Maximum output current	$I_{OUT MAX}$	$V_{IN} - V_{OUT} \leq 15V$		$T_J = 0$ to $125^\circ C$	1.5	2.2	-	A
		$V_{IN} - V_{OUT} = 40V$		$T_J = 25^\circ C$	0.15	0.4	-	
Output noise voltage (percentage of $V_{OUT}$ )	eN	$f = 10$ to $10kHz$		$T_J = 25^\circ C$	-	0.003	-	%
Ripple rejection	RR	$f = 100Hz$	$C_{ADJ}^{(9)} = 0\mu F$	$T_A = 25^\circ C$	-	60	-	dB
			$C_{ADJ}^{(9)} = 10\mu F$		-	65	-	
		$f = 1kHz$	$C_{ADJ}^{(9)} = 0\mu F$		-	64	-	
			$C_{ADJ}^{(9)} = 10\mu F$		-	75	-	

**Note:**

(6) Pulse testing techniques are used to maintain the junction temperature as close to the ambient temperature as possible.

(7) Typical numbers represent the most likely norm.

(8) The line regulation is calculated by the following formula:

$$LNR = \frac{\Delta V_{OUT}}{V_{OUT} \times \Delta V_{IN}}$$

where,  $\Delta V_{OUT}$  is the variation of the output voltage,  $\Delta V_{IN}$  is the variation of the input voltage.

(9)  $C_{ADJ}$  is connected between the ADJ terminal and GND.

7 Specifications

7.6 Typical Characteristics

LM317C ( $C_{IN} = 0.1\mu F$ ,  $C_{OUT} = 1\mu F$ , unless otherwise specified)

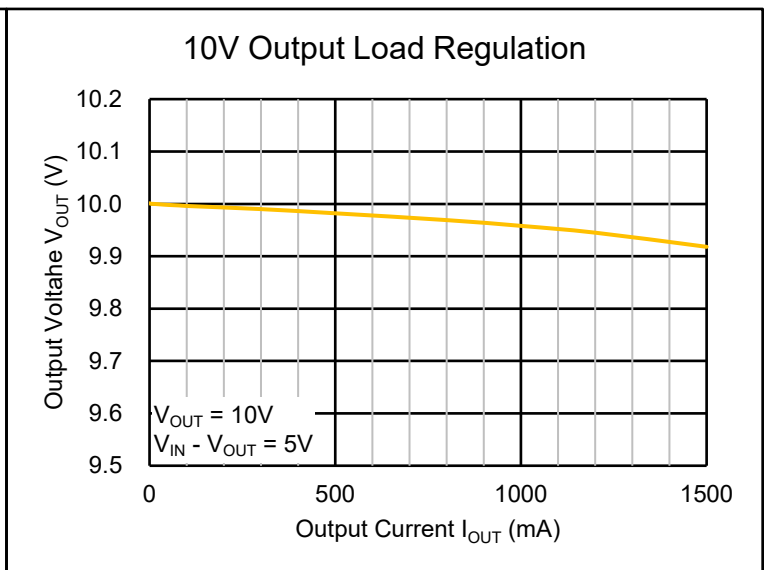
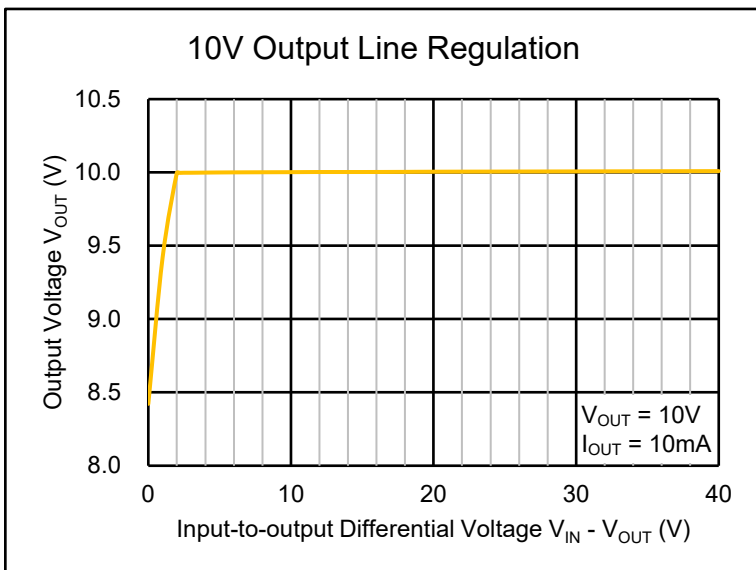
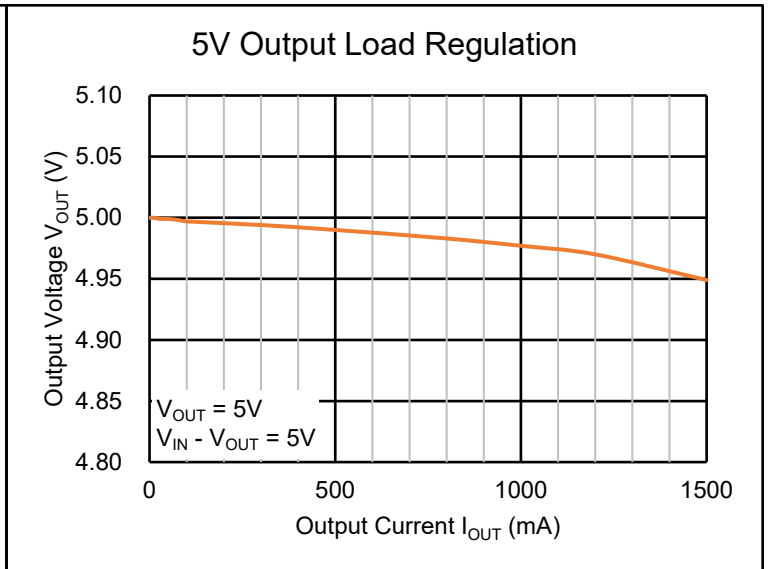
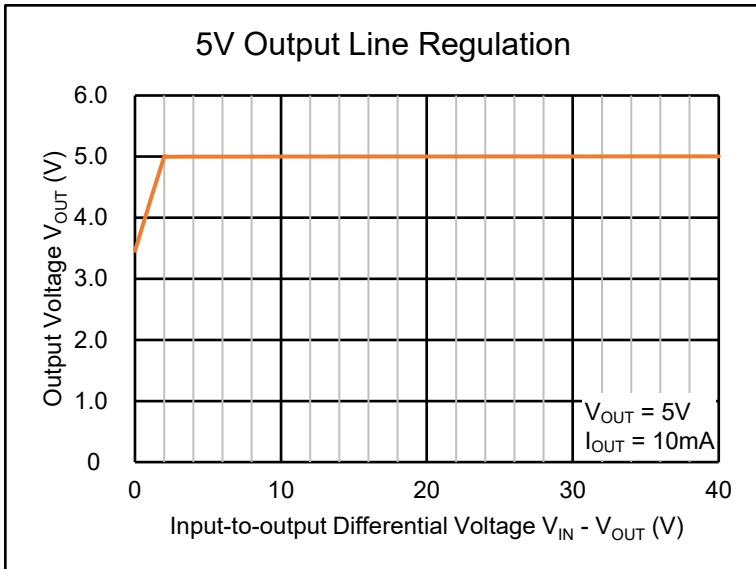
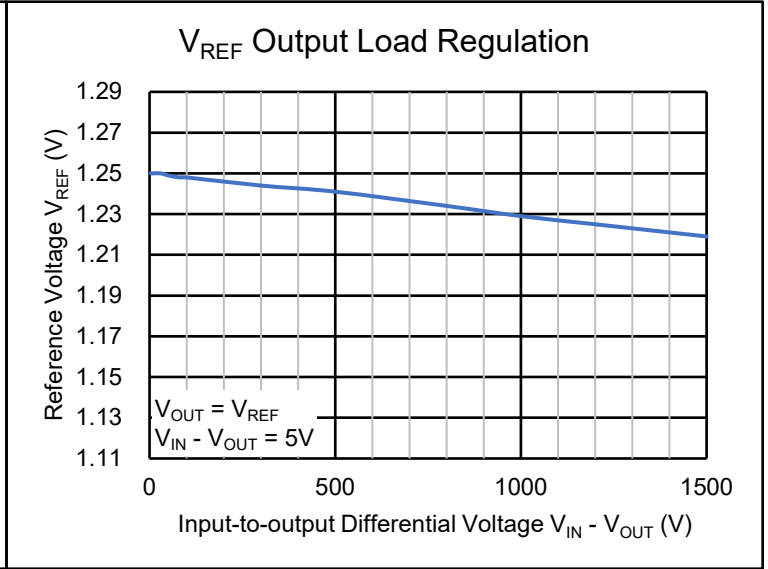
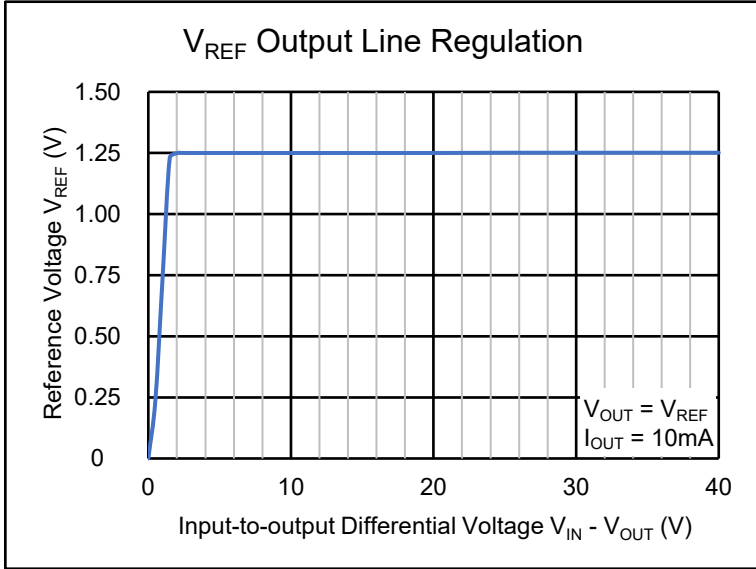

7 Specifications

7.6 Typical Characteristics (continued)

LM317C ( $C_{IN} = 0.1\mu F$ ,  $C_{OUT} = 1\mu F$ , unless otherwise specified)

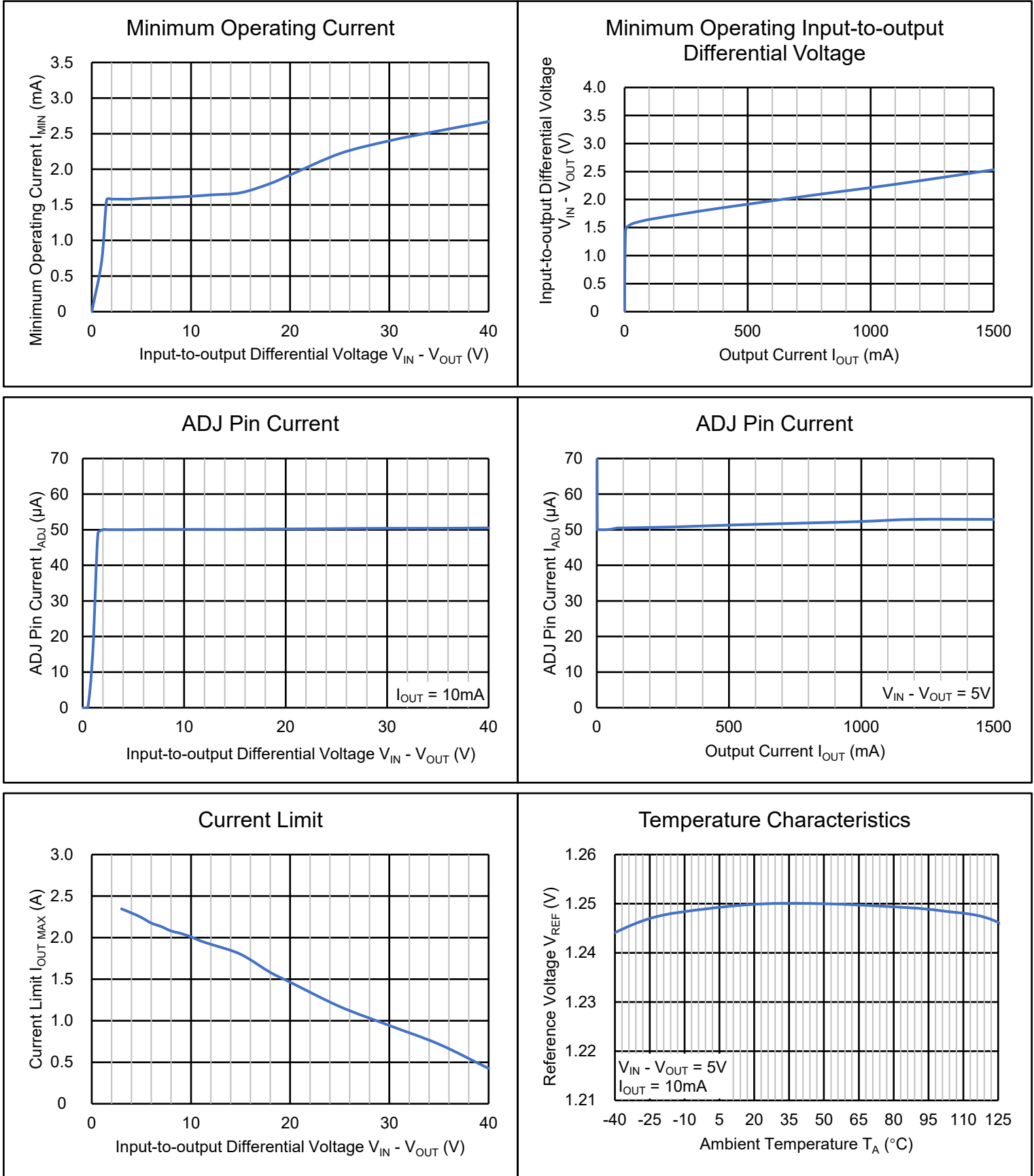

## 7 Specifications

### 7.6 Typical Characteristics (continued)

LM317C ( $C_{IN} = 0.1\mu\text{F}$ ,  $C_{OUT} = 1\mu\text{F}$ , unless otherwise specified)

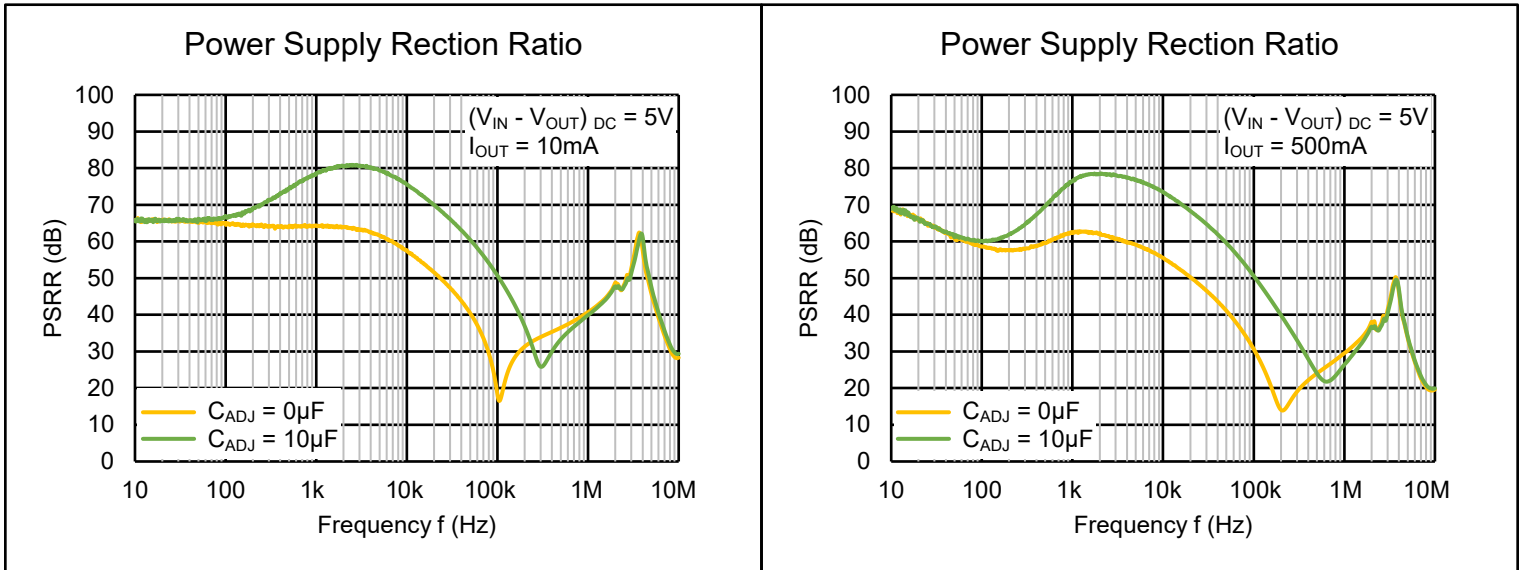

Load Transient ( $V_{OUT} = 10\text{V}$ ,  $V_{IN} - V_{OUT} = 5\text{V}$ ,  $I_{OUT} = 10 \sim 1000\text{mA}$ ,  $\text{CH}_2: V_{OUT}$ ,  $\text{CH}_4: I_{OUT}$ )

$C_{ADJ} = 0\mu\text{F}$

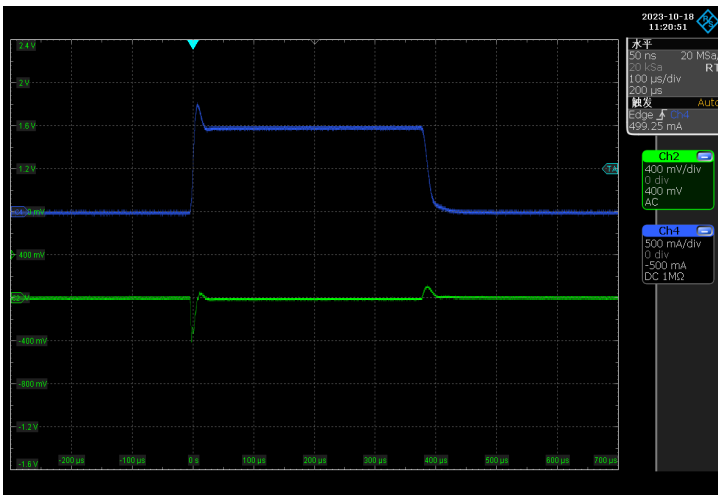

$C_{ADJ} = 10\mu\text{F}$

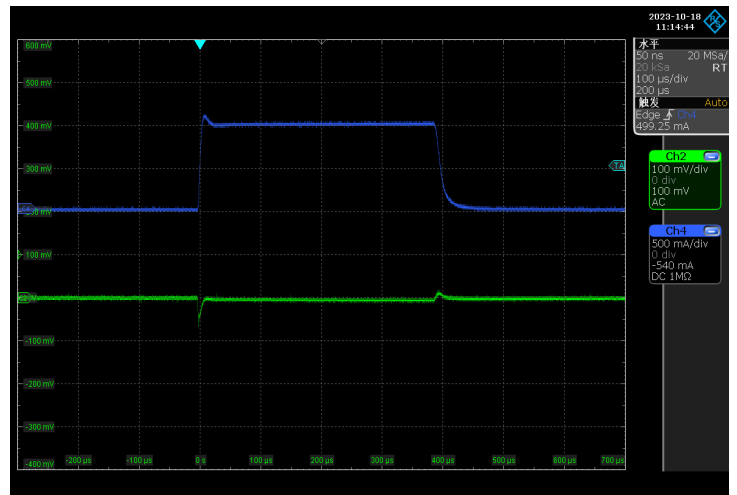

Power up Response ( $V_{OUT} = 10\text{V}$ ,  $V_{IN} = 0 \sim (V_{OUT} + 5\text{V})$ ,  $C_{ADJ} = 10\mu\text{F}$ ,  $\text{CH}_1: V_{IN}$ ,  $\text{CH}_2: V_{OUT}$ )

$I_{OUT} = 10\text{mA}$

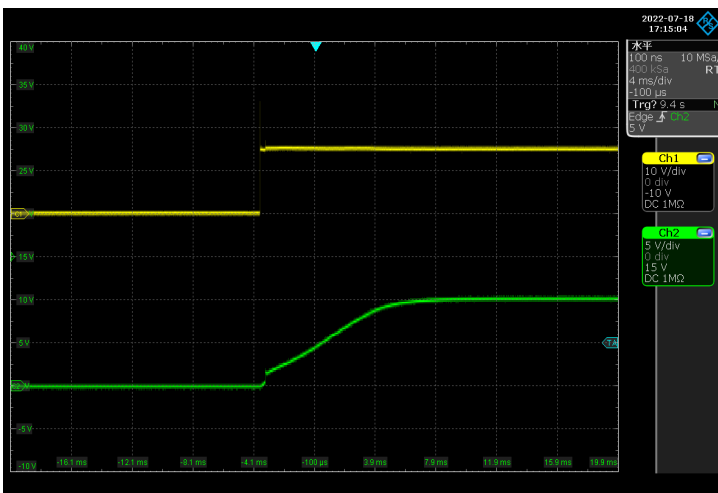

$I_{OUT} = 1000\text{mA}$

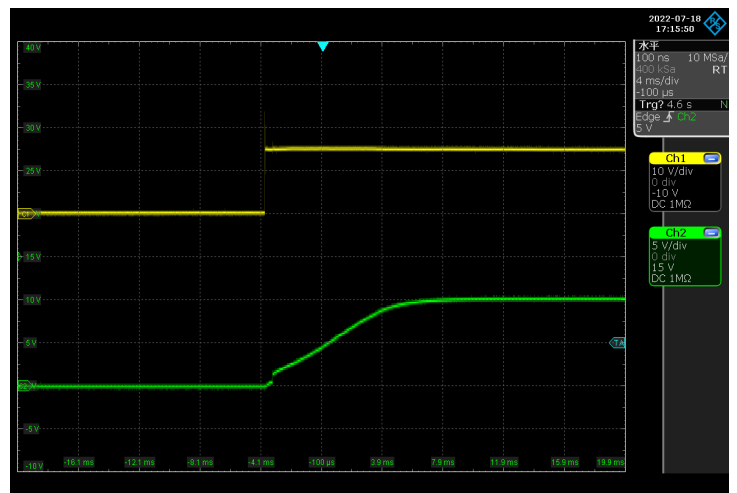

## 8 Detailed Description

### 8.1 Description

The LM317C is a three terminal positive voltage regulator with adjustable output. By setting two peripheral resistors, the output voltage range of the device can be set from 1.25V to 37V, and the current up to 1.5A can be provided. The LM317C integrates current limiting, thermal overload protection and safe operation area protection internally, and corresponding capacitors can be added to improve transient response. Therefore, the device is very easy to use, which is difficult to achieve with a standard three terminal regulator.

### 8.2 Representative Schematic Diagram

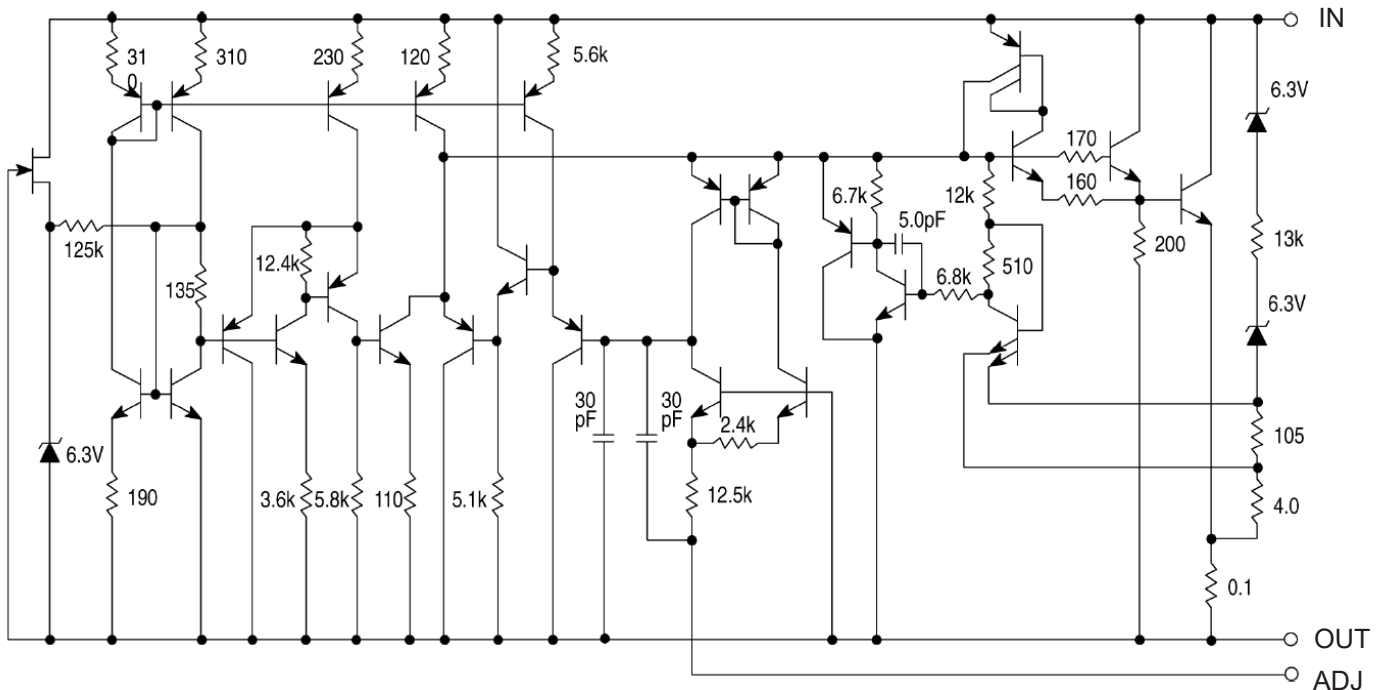

LM317C contains 29 transistors.

### 8.3 Feature Description

#### Comprehensive Overload Protection

The LM317C is internally integrated with current limit and thermal shutdown protection. When the output current is large or the junction temperature is higher than the rated range of the data sheet to a certain extent, the LM317C will enter the protection state and shut down the device to prevent accidental damage to the device. After the output current or junction temperature decreases to a certain extent, the LM317C will be released from the protection state and output normally.

When the output is short circuited, the LM317C will also enter the protection state and maintain the current at a low level. If the short circuit is removed, the LM317C will release the protection status and output normally.

## 8 Detailed Description

### 8.3 Feature Description (continued)

#### Minimum Operating Current

The LM317C needs to provide bias current between OUT and ADJ to make the device work normally. The load or feedback must consume this minimum current for regulation, otherwise the output may be too high. Refer to the *Electrical Characteristics* for the minimum load current required to maintain regulation.

#### Minimum Operating Voltage Difference

The LM317C requires a voltage difference ( $V_{IN} - V_{OUT}$ ) of at least 3V between input and output before it can operate in the normal working state, otherwise the device may not maintain the normal output state.

#### Programmable Feedback

The device will provide 1.25V (typical value) bias voltage between OUT and ADJ, and the output voltage or current (not both) can be easily programmed through external resistance. For current regulation applications, a single resistor with a resistance value of  $(1.25V / I_{OUT})$  and a rated power greater than  $((1.25V)^2 / R)$  shall be used. For voltage regulation applications, two resistors set the output voltage.

#### Normal Operation

The LM317C is a three terminal positive voltage regulator with adjustable output. During normal operation, the LM317C will maintain a reference voltage  $V_{REF}$  of 1.25V between OUT and ADJ. This reference voltage  $V_{REF}$  is converted from  $R_1$  to programming current  $I_{PROG}$  (see Figure 8-1), which flows to ground through  $R_2$ . The regulated output voltage is given by the following formula:

$$V_{OUT} = V_{REF} \times \left( 1 + \frac{R_2}{R_1} \right) + I_{ADJ} \times R_2$$

As an error term in the formula,  $I_{ADJ}$  is designed to be less than 100 $\mu$ A and keep constant. Therefore, in most applications, this item can be negligible.

Since the LM317C requires the minimum operating current and the minimum operating voltage difference for normal operation, the corresponding conditions shall be met in the circuit design.

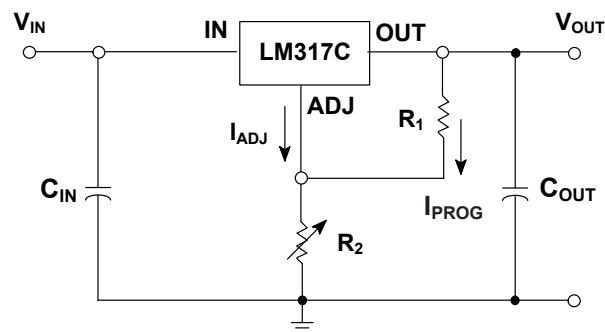

Figure 8-1. Basic Normal Operation

## 9 Application and Implementation

### 9.1 Application Information

#### Load Regulation

Following the following design recommendations can help the LM317C achieve better load regulation. The switching resistor  $R_1$  shall be connected as close to the voltage regulator as possible to minimize the voltage drop of the line effectively connected in series with the reference voltage and avoid poor adjustment rate. The grounding terminal of  $R_2$  can be returned close to the load grounding terminal to provide remote grounding sampling and improve the load adjustment rate.

#### External Capacitors

A  $0.1\mu\text{F}$  disc or  $1.0\mu\text{F}$  tantalum input bypass capacitor  $C_{IN}$  is recommended to reduce the sensitivity to input line impedance. The adjustment terminal may be bypassed to ground to improve ripple rejection.

A  $C_{ADJ}$  of  $10\mu\text{F}$  (between OUT and GND) is recommended to improve ripple rejection. It prevents amplification of the ripple as the output voltage is adjusted higher.

Although the LM317C is stable with no output capacitance, like any feedback circuit, certain values of external capacitance can cause excessive ringing. An output capacitance  $C_{OUT}$  in the form of a  $1.0\mu\text{F}$  tantalum or  $25\mu\text{F}$  aluminum electrolytic capacitor on the output swamps this effect and insures stability. The  $C_{IN}$  and  $C_{OUT}$  should be placed as close to the corresponding device pins as possible.

When the LM317C is used as a reference voltage source instead of a peripheral resistor, it is recommended to use an input capacitor of  $1.0\mu\text{F}$  or more to obtain better voltage stability.

#### Protection Diodes

When external capacitors are used with any IC regulator it is sometimes necessary to add protection diodes to prevent the capacitors from discharging through low current points into the regulator. Figure 9-1 shows the LM317C with the recommended protection diodes for output voltages in excess of 25V or high capacitance values ( $C_{OUT} > 25\mu\text{F}$ ,  $C_{ADJ} > 10\mu\text{F}$ ). Diode  $D_1$  prevents  $C_{OUT}$  from discharging through the IC during an input short circuit. Diode  $D_2$  protects against capacitor  $C_{ADJ}$  discharging through the IC during an output short circuit. The combination of diodes  $D_1$  and  $D_2$  prevents  $C_{ADJ}$  from discharging through the IC during an input short circuit.

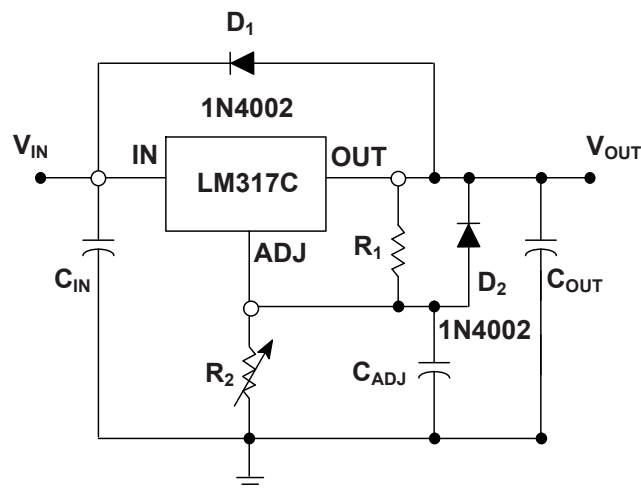

Figure 9-1. Voltage Regulator with Protection Diodes

9 Application and Implementation

9.2 System Example

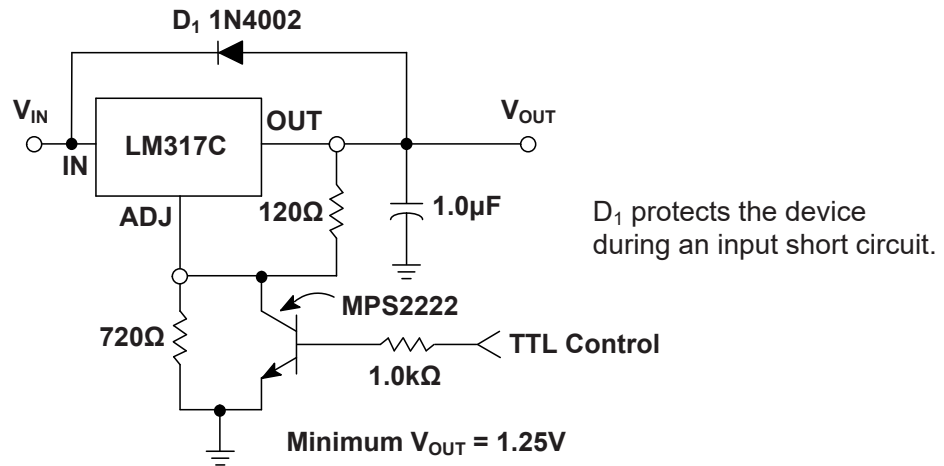

Figure 9-2. 5V Electronic Shutdown Regulator

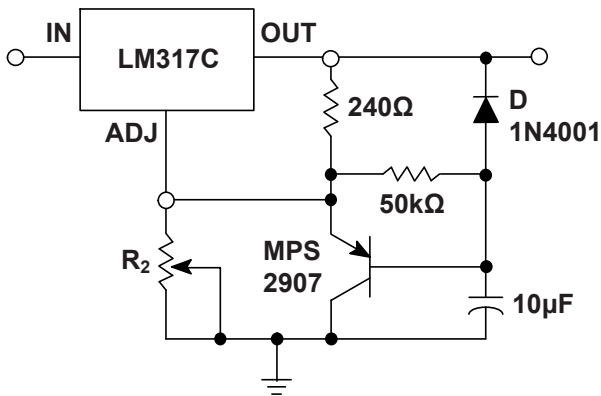
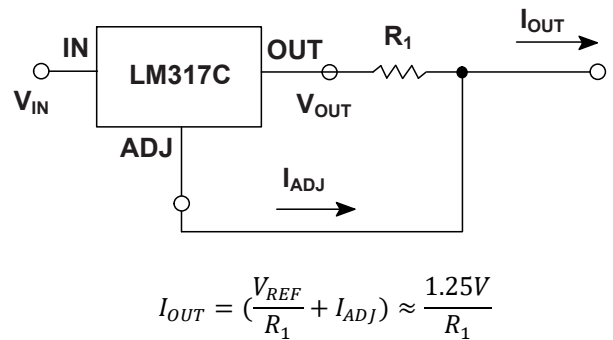

Figure 9-3. Slow Turn-On Regulator



$$I_{OUT} = \left( \frac{V_{REF}}{R_1} + I_{ADJ} \right) \approx \frac{1.25V}{R_1}$$

Figure 9-4. Current Regulator

**NOTE**

The application information in this section is not part of the data sheet component specification, and JSCJ makes no commitment or statement to guarantee its accuracy or completeness. Customers are responsible for determining the rationality of corresponding components in their circuit design and making tests and verifications to ensure the normal realization of their circuit design.

10 Mechanical Information

10.1 SOT-223 Mechanical Information

SOT-223 Outline Dimensions

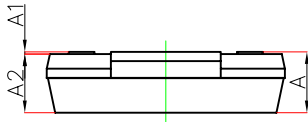
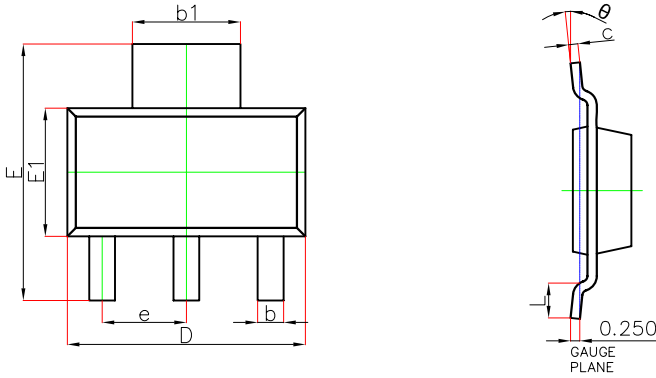

Symbol	Dimensions In Millimeters		Dimensions In Inches	
	Min.	Max.	Min.	Max.
A	—	1.800	—	0.071
A1	0.020	0.100	0.001	0.004
A2	1.500	1.700	0.059	0.067
b	0.660	0.840	0.026	0.033
b1	2.900	3.100	0.114	0.122
c	0.230	0.350	0.009	0.014
D	6.300	6.700	0.248	0.264
E	6.700	7.300	0.264	0.287
E1	3.300	3.700	0.130	0.146
e	2.300(BSC)		0.091(BSC)	
L	0.750	—	0.030	—
θ	0°	10°	0°	10°

SOT-223 Suggested Pad Layout

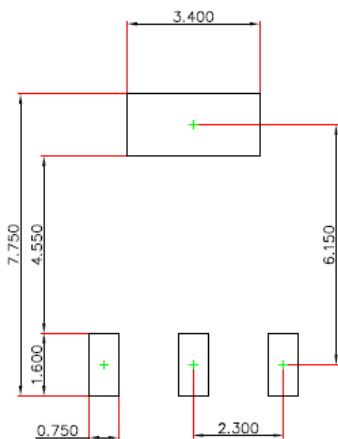

Note:

1. Controlling dimension: in millimeters.
2. General tolerance: ±0.05mm.
3. The pad layout is for reference purposes only.

10 Mechanical Information

10.2 TO-220-3L Mechanical Information

TO-220-3L Outline Dimensions

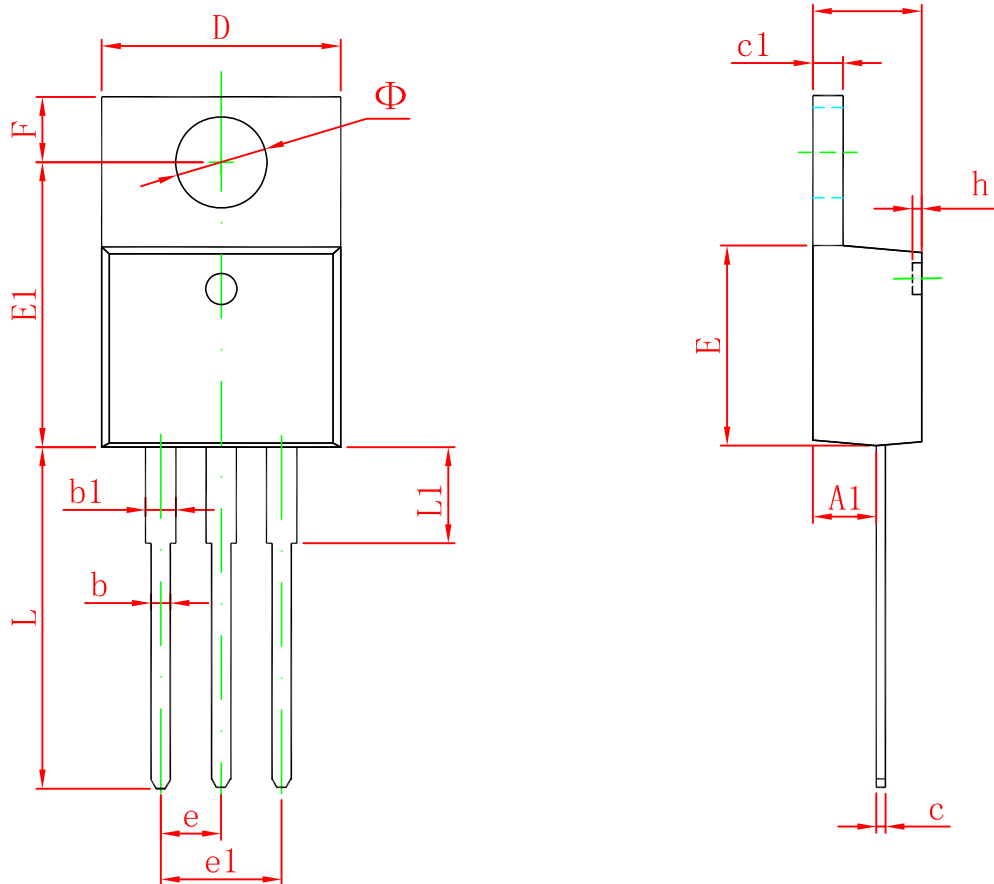

Symbol	Dimensions In Millimeters		Dimensions In Inches	
	Min	Max	Min	Max
A	4.470	4.670	0.176	0.184
A1	2.520	2.820	0.099	0.111
b	0.710	0.910	0.028	0.036
b1	1.170	1.370	0.046	0.054
c	0.310	0.530	0.012	0.021
c1	1.170	1.370	0.046	0.054
D	10.010	10.310	0.394	0.406
E	8.500	8.900	0.335	0.350
E1	12.060	12.460	0.475	0.491
e	2.540 TYP		0.100 TYP	
e1	4.980	5.180	0.196	0.204
F	2.590	2.890	0.102	0.114
h	0.000	0.300	0.000	0.012
L	13.400	13.800	0.528	0.543
L1	3.560	3.960	0.140	0.156
$\Phi$	3.735	3.935	0.147	0.155

10 Mechanical Information

10.3 TO-252-2L Mechanical Information

TO-252-2L Outline Dimensions

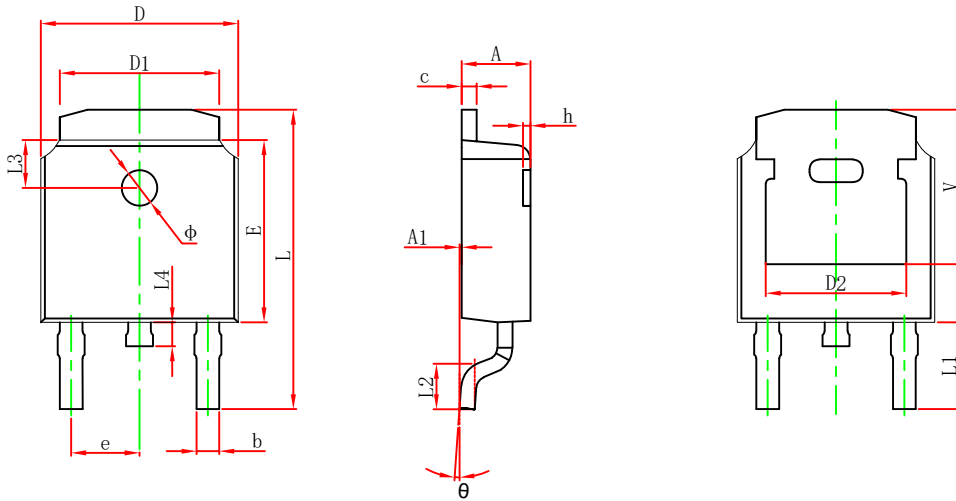

Symbol	Dimensions In Millimeters		Dimensions In Inches	
	Min.	Max.	Min.	Max.
A	2.200	2.400	0.087	0.094
A1	0.000	0.127	0.000	0.005
b	0.635	0.770	0.025	0.030
c	0.460	0.580	0.018	0.023
D	6.500	6.700	0.256	0.264
D1	5.100	5.460	0.201	0.215
D2	4.830 REF.		0.190 REF.	
E	6.000	6.200	0.236	0.244
e	2.186	2.386	0.086	0.094
L	9.712	10.312	0.382	0.406
L1	2.900 REF.		0.114 REF.	
L2	1.400	1.700	0.055	0.067
L3	1.600 REF.		0.063 REF.	
L4	0.600	1.000	0.024	0.039
phi	1.100	1.300	0.043	0.051
theta	0°	8°	0°	8°
h	0.000	0.300	0.000	0.012
V	5.250 REF.		0.207 REF.	

TO-252-2L Suggest Pad Layout

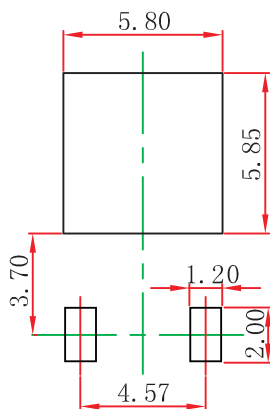

Note:

1. Controlling dimension: in millimeters.
2. General tolerance: ±0.05mm.
3. The pad layout is for reference purposes only.

## 10 Mechanical Information

### 10.4 TO-263-2L Mechanical Information

#### TO-263-2L Outline Dimensions

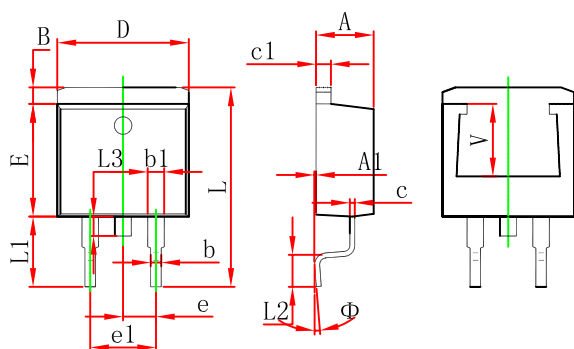

Symbol	Dimensions In Millimeters		Dimensions In Inches	
	Min.	Max.	Min.	Max.
A	4.470	4.670	0.176	0.184
A1	0.000	0.150	0.000	0.006
B	1.120	1.420	0.044	0.056
b	0.710	0.910	0.028	0.036
b1	1.170	1.370	0.046	0.054
c	0.310	0.530	0.012	0.021
c1	1.170	1.370	0.046	0.054
D	10.010	10.310	0.394	0.406
E	8.500	8.900	0.335	0.350
e	2.540 TYP.		0.100 TYP.	
e1	4.980	5.180	0.196	0.204
L	14.940	15.500	0.588	0.610
L1	4.950	5.450	0.195	0.215
L2	2.340	2.740	0.092	0.108
L3	1.300	1.700	0.051	0.067
Φ	0°	8°	0°	8°
V	5.600 REF.		0.220 REF.	

#### TO-263-2L Suggest Pad Layout

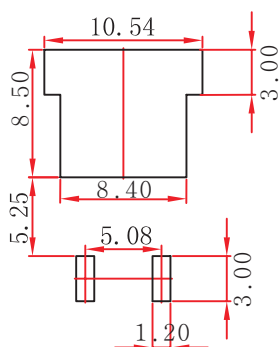

**Note:**

1. Controlling dimension: in millimeters.
2. General tolerance: ±0.05mm.
3. The pad layout is for reference purposes only.

## 11 Packaging Information

### 11.1 SOT-223 Tape and Reel Information

#### SOT-223 Embossed Carrier Tape

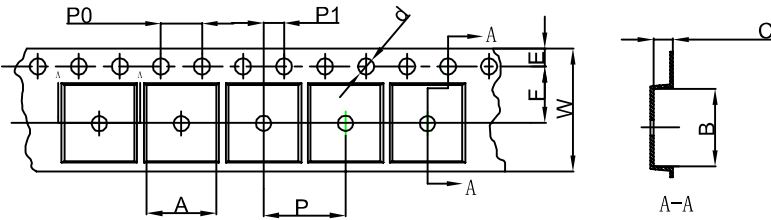

**Packaging Description:**

SOT-223 parts are shipped in tape. The carrier tape is made from a dissipative (carbon filled) polycarbonate resin. The cover tape is a multilayer film (Heat Activated Adhesive in nature) primarily composed of polyester film, adhesive layer, sealant, and anti-static sprayed agent. These reeled parts in standard option are shipped with 2,500 units per 13" or 33.0cm diameter reel. The reels are clear in color and is made of polystyrene plastic (anti-static coated),

Dimensions are in millimeter										
Pkg type	A	B	C	d	E	F	P0	P	P1	W
SOT-223	6.765	7.335	1.88	Ø1.50	1.75	5.50	4.00	8.00	2.00	12.00

#### SOT-223 Tape Leader and Trailer

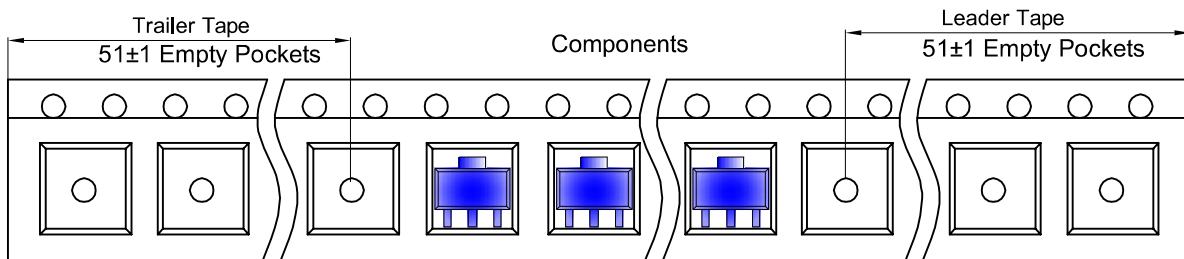

#### SOT-223 Reel

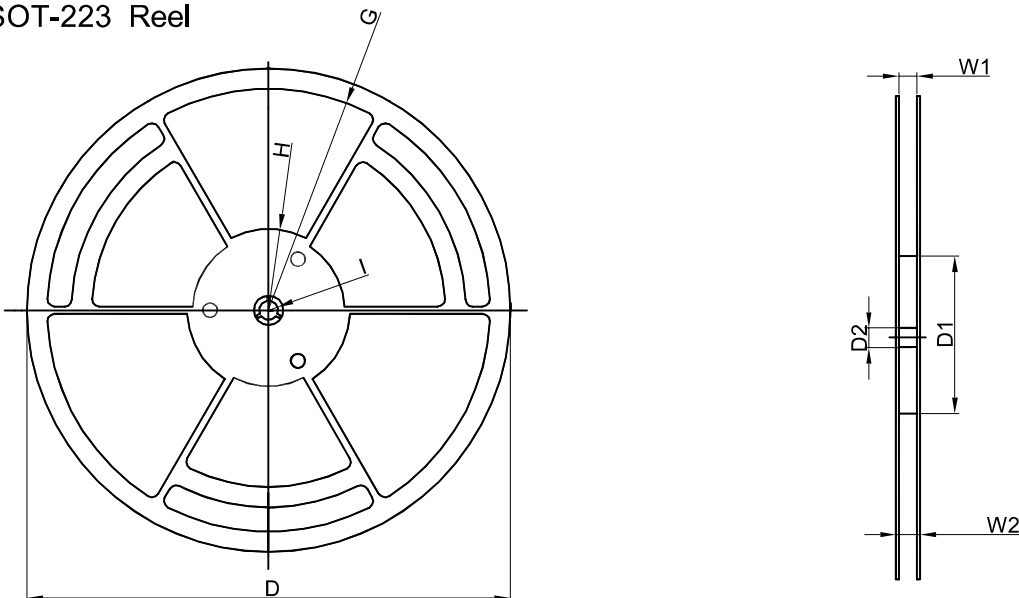

Dimensions are in millimeter								
Reel Option	D	D1	D2	G	H	I	W1	W2
13" Dia	φ330.00	100.00	13.00	R151.00	R56.00	R6.50	12.40	17.60

Reel	Reel Size	Box	Box Size (mm)	Carton	Carton Size (mm)
2,500 pcs	13 inch	5,000 pcs	360×360×65	25,000 pcs	378×358×382

## 11 Packaging Information

### 11.2 TO-252-2L Tape and Reel Information

#### TO-252-2L Embossed Carrier Tape

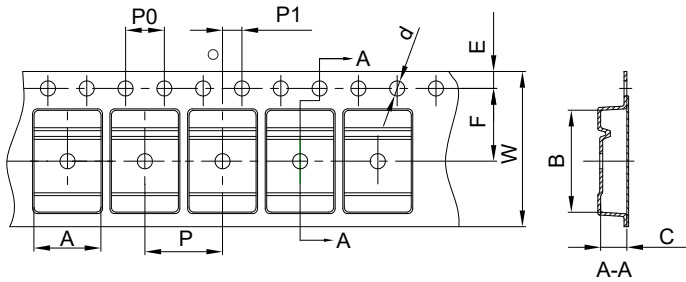

**Packaging Description:**

TO-252-2L parts are shipped in tape. The carrier tape is made from a dissipative (carbon filled) polycarbonate resin. The cover tape is a multilayer film (Hear Activated Adhesive in nature) primarily composed of polyester film, adhesive layer, sealant, and anti-static sprayed agent. These reeled parts in standard option are shipped with 2500 units per 13" or 33.0 cm diameter reel. The reels are clear in color and is made of polystyrene plastic (anti-static coated).

Dimensions are in millimeter										
Pkg type	A	B	C	d	E	F	P0	P	P1	W
TO-252	6.90	10.50	2.70	Φ1.55	1.75	7.50	4.00	8.00	2.00	16.00

#### TO-252-2L Tape Leader and Trailer

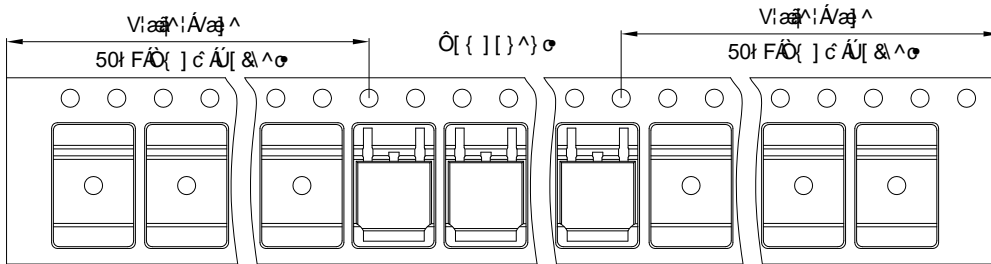

#### TO-252-2L Reel

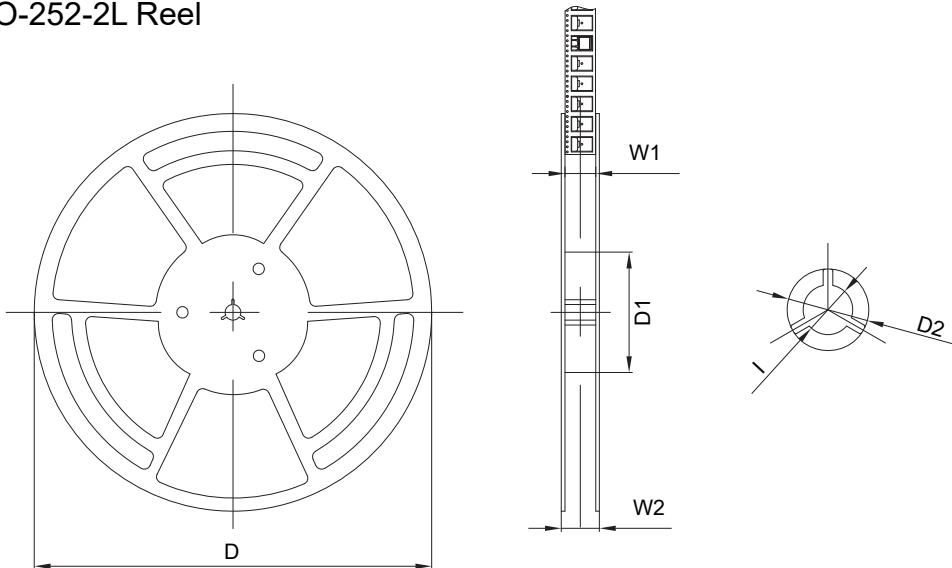

Dimensions are in millimeter						
Reel	D	D1	D2	W1	W2	l
13" Dia	330.00	100.00	Φ21.00	16.40	21.40	Φ13.00

Reel	Reel Size	Box	Box Size(mm)	Carton	Carton Size(mm)
2500 pcs	13 inch	5000 pcs	360×360×65	25000 pcs	378×358×382

## 11 Packaging Information

### 11.3 TO-263-2L Tape and Reel Information

#### TO-263-2L Embossed Carrier Tape

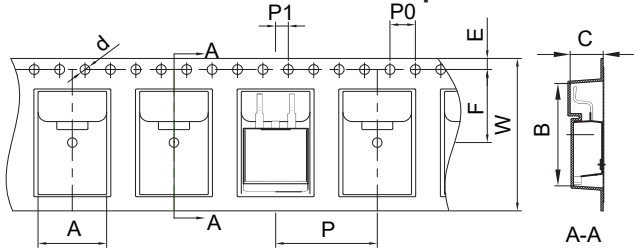

**Packaging Description:**

TO-263-2L parts are shipped in tape. The carrier tape is made from a dissipative (carbon filled) polycarbonate resin. The cover tape is a multilayer film (Hear Activated Adhesive in nature) primarily composed of polyester film, adhesive layer, sealant, and anti-static sprayed agent. These reeled parts in standard option are shipped with 800 units per 13" or 33.0 cm diameter reel. The reels are clear in color and is made of polystyrene plastic (anti-static coated).

Dimensions are in millimeter										
Pkg type	A	B	C	d	E	F	P0	P	P1	W
TO-263	10.80	16.13	5.21	Φ1.55	1.75	11.50	4.00	16.00	2.00	24.00

#### TO-263-2L Tape Leader and Trailer

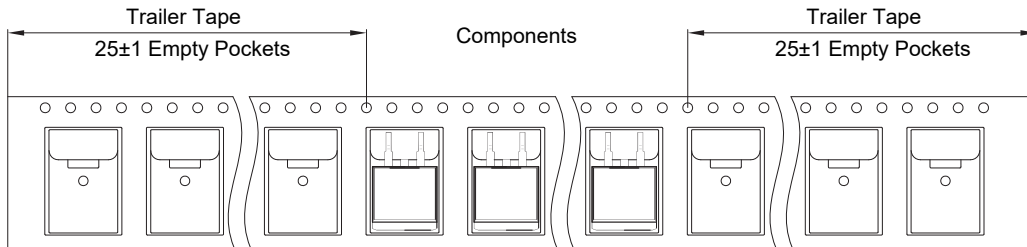

#### TO-263-2L Reel

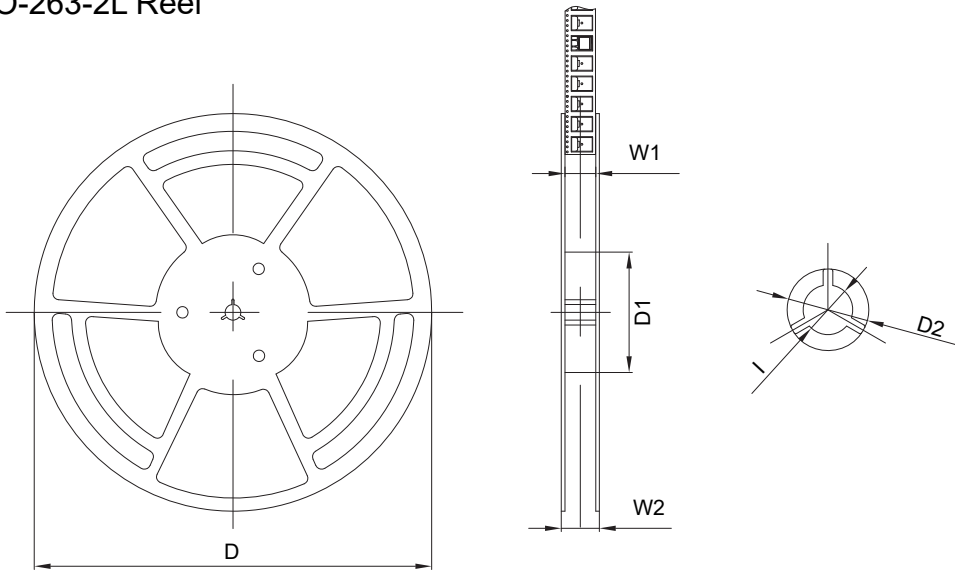

Dimensions are in millimeter						
Reel	D	D1	D2	W1	W2	l
13" Dia	330.00	100.00	Φ21.00	24.40	30.40	Φ13.00

Reel	Reel Size	Box	Box Size(mm)	Carton	Carton Size(mm)
800 pcs	13 inch	1600 pcs	360×360×65	8000 pcs	378×358×382

## 12 Notes and Revision History

### 12.1 Associated Product Family and Others

To view other products of the same type or IC products of other types, click the official website of JSCJ <https://www.jscj-elec.com> for more details.

### 12.2 Notes

#### Electrostatic Discharge Caution



This IC may be damaged by ESD. Relevant personnel shall comply with correct installation and use specifications to avoid ESD damage to the IC. If appropriate measures are not taken to prevent ESD damage, the hazards caused by ESD include but are not limited to degradation of integrated circuit performance or complete damage of integrated circuit. For some precision integrated circuits, a very small parameter change may cause the whole device to be inconsistent with its published specifications.

### 12.3 Revision History

#### October, 2023: changed from rev - 1.2 to rev - 1.3:

- Page 1, Features, output adjustable range changed from "1.2V to 37V" to "1.25V to 37V";
- Page 4, Recommend Operating Conditions, output adjustable range changed from "1.2V to 37V" to "1.25V to 37V";
- Page 6, Electrical Characteristics, PSRR is changed from "120Hz" to "100Hz and 1kHz";
- Page 8, Typical Characteristics, added the figure of the "Temperature Characteristics";
- Page 9, Typical Characteristics, removed the figures of the "SCP";
- Page 21, removed the notes of the thermal metric.

#### February, 2023: changed from rev - 1.1 to rev - 1.2:

- Page 5, Thermal Information, added junction-to-case thermal resistance  $R_{\theta JC}$ .

#### August 2022: changed from rev - 1.0 to rev - 1.1:

- Modified data sheet format: All data sheet, added headers, changed font size;
- Page 1, modified footer;
- Page 1, Introduction, Features, output voltage range changed from 1.25V to 1.2V;
- Page 2, Orderable Information, changed Max OP  $T_J$ : 125°C to OP  $T_J$ : -40 to 125°C;
- Page 4, Recommended Operating Conditions, changed OP  $T_J$  from 0 to 125°C to -40 to 125°C;
- Page 4, Absolute Maximum Ratings, Recommended Operating Conditions, changed OP  $T_J$  from 0 to 125°C to -40 to 125°C.

#### June 2022: released LM317C rev - 1.0.

# DISCLAIMER

## **IMPORTANT NOTICE, PLEASE READ CAREFULLY**

The information in this data sheet is intended to describe the operation and characteristics of our products. JSCJ has the right to make any modification, enhancement, improvement, correction or other changes to any content in this data sheet, including but not limited to specification parameters, circuit design and application information, without prior notice.

Any person who purchases or uses JSCJ products for design shall: 1. Select products suitable for circuit application and design; 2. Design, verify and test the rationality of circuit design; 3. Procedures to ensure that the design complies with relevant laws and regulations and the requirements of such laws and regulations. JSCJ makes no warranty or representation as to the accuracy or completeness of the information contained in this data sheet and assumes no responsibility for the application or use of any of the products described in this data sheet.

Without the written consent of JSCJ, this product shall not be used in occasions requiring high quality or high reliability, including but not limited to the following occasions: medical equipment, military facilities and aerospace. JSCJ shall not be responsible for casualties or property losses caused by abnormal use or application of this product.

Official Website: [www.jscj-elec.com](http://www.jscj-elec.com)

Copyright © JIANGSU CHANGJING ELECTRONICS TECHNOLOGY CO., LTD.