

LM317D Adjustable Three-Terminal Regulator

1 Introduction

The LM317D is a three terminal positive voltage regulator with maximum 1.0A current output and adjustable output. The voltage regulator is very easy to use, which only needs two external resistors to set the output voltage, and the output voltage can be set in the range of 1.25V to 37V. In addition, the LM317D is also designed to integrate internal current limiting, thermal shutdown and safe working area compensation, which makes it relatively difficult to damage and basically prevent the burning of circuit fuses.

The LM317D serves a variety of applications, including local voltage stabilization and card voltage stabilization. It can also be used to make a programmable voltage regulator, or as a precision current regulator by connecting a fixed resistance between the adjustment point and the output.

2 Available Packages

PART NUMBER	PACKAGE
LM317D	SOT-223
	TO-220-3L
	TO-252-2L
	TO-263-2L

3 Features

- The output current exceeds 1.0A
- The output is adjustable from 1.25V to 37V
- Internal thermal overload protection
- Temperature independent internal short circuit current limit
- Output transistor safe working area compensation
- Commonly used TO-252 package, as well as other forms of three pin package
- Avoid preparing multiple fixed voltages

4 Applications

- Base Station
- Desktop Computer
- Ethernet Switch, Public Server, Private Switch (PBX)
- IP Telephone: Wired and Wireless
- Motor Control
- Refrigerator, Air Conditioner, Washing Machine
- Security Camera, Digital Sign
- Signal or Waveform Generator
- Substation Control, Power Quality Meter

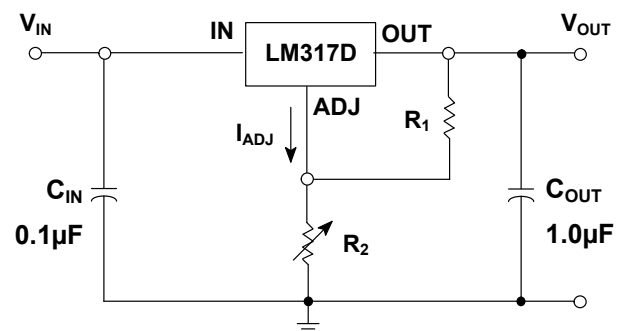

Typical Application Circuits

Please carefully read the notice at the end of this data sheet about product use, data sheet changes and important statements.

5 Orderable Information

MODEL	DEVICE	PACKAGE	OP T _J	ECO PLAN	MSL	PACKING OPTION	SORT
-	LM317D	SOT-223	-40 ~ 125°C	RoHS & Green	Level 3 168 HR	Tape and Reel 2500 Units / Reel	Active
-		TO-220-3L	-40 ~ 125°C	RoHS & Green	N / A for Pkg Type	Tube 50 Units / Rail	Active
-		TO-252-2L	-40 ~ 125°C	RoHS & Green	Level 3 168 HR	Tape and Reel 2500 Units / Reel	Active
-		TO-263-2L	-40 ~ 125°C	RoHS & Green	N / A for Pkg Type	Tape and Reel 800 Units / Reel	Active
Others	-	-	-	-	-	-	Customized

Note:

ECO PLAN: For the RoHS and Green certification standards of this product, please refer to the official report provided by JSCJ.

MSL: Moisture Sensitivity Level. Determined according to JEDEC industry standard classification.

SORT: Specifically defined as follows:

Active: Recommended for new products;

Customized: Products manufactured to meet the specific needs of customers;

Preview: The device has been released and has not been fully mass produced. The sample may or may not be available;

NoRD: It is not recommended to use the device for new design. The device is only produced for the needs of existing customers;

Obsolete: The device has been discontinued.

6 Pin Configuration and Marking Information

6.1 Pin Configuration and Function

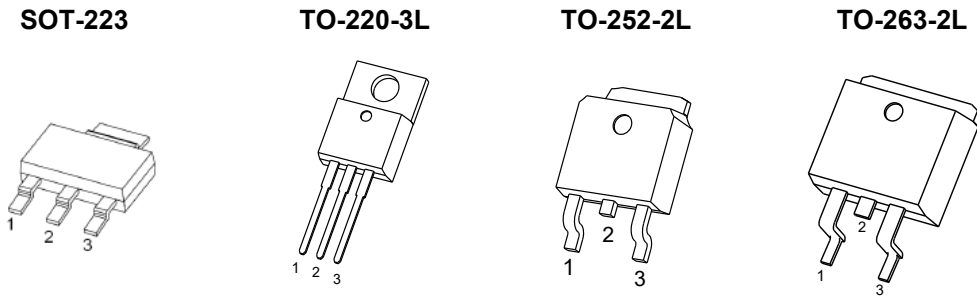
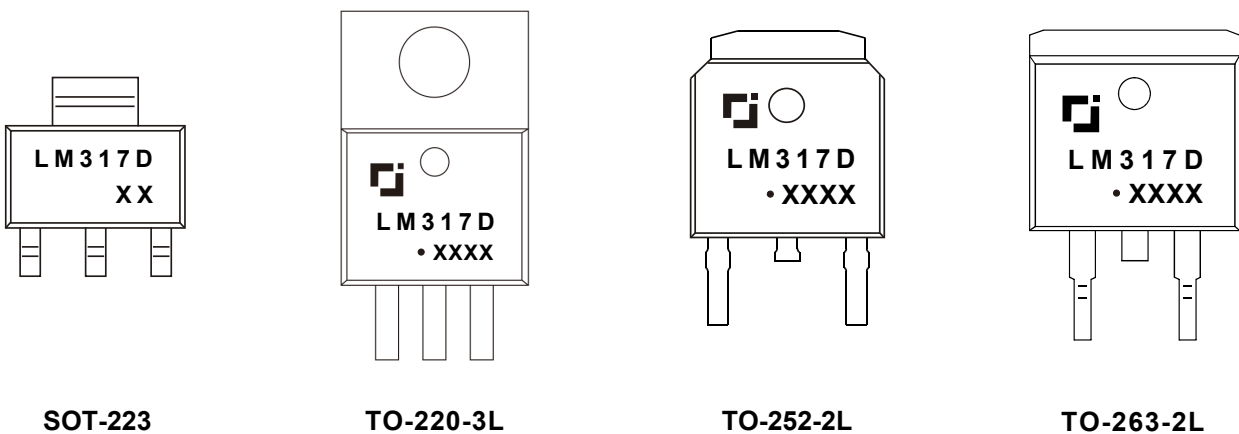

Figure 6-1. Package Top View

PIN NAME	LM317D				I / O	DESCRIPTION
	SOT-223	TO-220-3L	TO-252-2L	TO-263-2L		
IN	3	3	3	3	I	Supply input pin.
ADJ	1	1	1	1	-	Adjustment pin. Connect to a resistor divider to set V_{OUT} .
OUT	2	2	2	2	O	Voltage output pin.

6.2 Marking Information



"LM317D" : Device number.

"XX" & "XXXX" : Code. Indicates weekly record information of production.

" . " : Green molding compound device.

7 Specifications

7.1 Absolute Maximum Ratings

(over operating free-air temperature range, unless otherwise specified)⁽¹⁾

CHARACTERISTIC		SYMBOL	VALUE	UNIT
Input-to-output differential voltage		$V_{IN} - V_{OUT}$	40	V
Programmable output voltage range		V_{OUT}	37	
Maximum power dissipation	LM317D	SOT-223	Internally Limited ⁽²⁾	W
		TO-220-3L		
		TO-252-2L		
		TO-263-2L		
Maximum junction temperature		$T_{J\ Max}$	150	°C
Storage temperature		T_{stg}	-65 ~ 150	°C
Soldering temperature & time		T_{solder}	260°C, 10s	-

(1) Stresses beyond those listed under *Absolute Maximum Ratings* may cause permanent damage to the device. These are stress ratings only, which do not imply functional operation of the device at these or any other condition beyond those indicated under *Recommended Operating Conditions*. Exposure to absolute-maximum rated conditions for extended periods may affect device reliability.

(2) Refer to *Thermal Information* for details.

7.2 Recommended Operating Conditions

PARAMETER	SYMBOL	MIN.	NOM.	MAX.	UNIT
Input-to-output differential voltage	$V_{IN} - V_{OUT}$	3.0	-	40	V
Programmable output voltage	V_{OUT}	1.25	-	37	V
Output current range	I_{OUT}	0.01	-	1.0	A
Operating junction temperature	T_J	-40	-	125	°C

7.3 Thermal Information

THERMAL METRIC ⁽³⁾	SYMBOL	LM317D				UNIT
		SOT-223	TO-220-3L	TO-252-2L	TO-263-2L	
Junction-to-ambient thermal resistance	$R_{\theta JA}$	102.6	68.2	81.4	63.5	°C/W
Junction-to-case thermal resistance	$R_{\theta JC}$	27.4	5.9	15.2	5.7	°C/W
Maximum power dissipation for continuous operation	$P_{D\ Ref}$	1.00	1.50	1.25	1.60	W

(3) Thermal metric is measured in still air with $T_A = 25^\circ\text{C}$ and installed on a 1 in² FR-4 board covered with 2 ounces of copper.

7 Specifications

7.4 Electrical Characteristics

LM317D ($V_{IN} - V_{OUT} = 5.0V$, $I_{OUT} = 500mA$, $C_{IN} = 0.1\mu F$, $C_{OUT} = 1\mu F$, $T_J = 25^\circ C$, unless otherwise specified)

CHARACTERISTIC	SYMBOL	TEST CONDITIONS ⁽⁶⁾		MIN.	TYP.	MAX.	UNIT
Line regulation	LNR ⁽⁷⁾	$V_{IN} - V_{OUT} = 3.0$ to $40V$		-	0.01	0.04	%/V
Load regulation	LDR	$I_{OUT} = 10$ to $1000mA$	$V_{OUT} < 5.0V$	-	5.0	25	mV
			$V_{OUT} \geq 5.0V$	-	0.1	0.5	%· V_{OUT}
ADJUST terminal current	I_{ADJ}	-		-	50	100	μA
Change in ADJUST terminal current	ΔI_{ADJ}	$V_{IN} - V_{OUT} = 2.5$ to $40V$ $I_{OUT} = 10$ to $1000mA$		-	0.2	5.0	μA
Reference voltage	V_{REF}	$V_{IN} - V_{OUT} = 3.0$ to $40V$ $I_{OUT} = 10$ to $1000mA$		1.20	1.25	1.30	V
Line regulation of reference voltage	LNR V_{REF}	$V_{IN} - V_{OUT} = 3.0$ to $40V$		-	0.02	0.07	%/V
Load regulation of reference voltage	LDR V_{REF}	$I_{OUT} = 10$ to $1000mA$	$V_{OUT} < 5.0V$	-	20	70	mV
			$V_{OUT} \geq 5.0V$	-	0.3	1.5	%· V_{OUT}
Output voltage temperature stability	$\frac{\Delta V_{OUT}}{V_{OUT}}$	$T_J = 0 \sim 125^\circ C$		-	0.7	-	%
Minimum load current to maintain regulation	$I_{OUT MIN}$	$V_{IN} - V_{OUT} = 40V$		-	3.5	10	mA
Maximum output current	$I_{OUT MAX}$	$V_{IN} - V_{OUT} \leq 15V$		-	1.0	-	A
		$V_{IN} - V_{OUT} = 40V$		0.15	0.4	-	
Output noise voltage (percentage of V_{OUT})	eN	$f = 10$ to $10k$ Hz		-	0.003	-	%
Ripple rejection	RR	$C_{ADJ}^{(8)} = 0\mu F$, $T_A = 25^\circ C$	$f = 100Hz$	-	50	-	dB
			$f = 1kHz$	-	56	-	
		$C_{ADJ}^{(8)} = 10\mu F$, $T_A = 25^\circ C$	$f = 100Hz$	-	53	-	
			$f = 1kHz$	-	72	-	

Note:

- (6) Pulse testing techniques are used to maintain the junction temperature as close to the ambient temperature as possible.
- (7) The line regulation is calculated by the following formula:

$$LNR = \frac{\Delta V_{OUT}}{V_{OUT} \times \Delta V_{IN}}$$

where, ΔV_{OUT} is the variation of the output voltage, ΔV_{IN} is the variation of the input voltage.

(8) C_{ADJ} is connected between the ADJ terminal and GND.

7 Specifications

7.5 Typical Characteristics

LM317D ($V_{IN} - V_{OUT} = 5V$, $I_{OUT} = 10mA$, $C_{IN} = 0.1\mu F$, $C_{OUT} = 1.0\mu F$, $T_A = 25^\circ C$, unless otherwise specified)

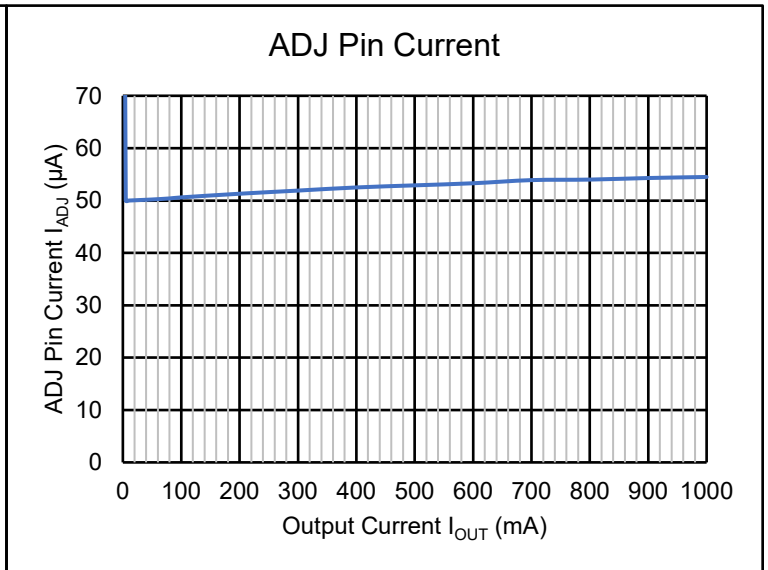
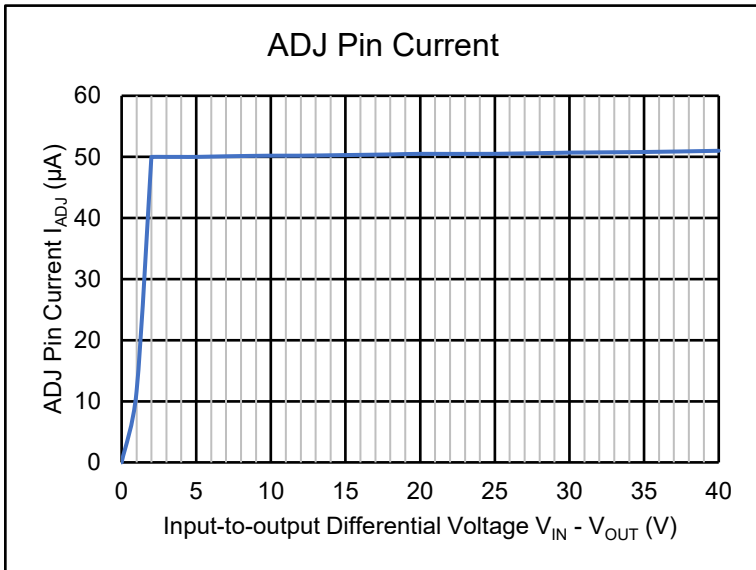
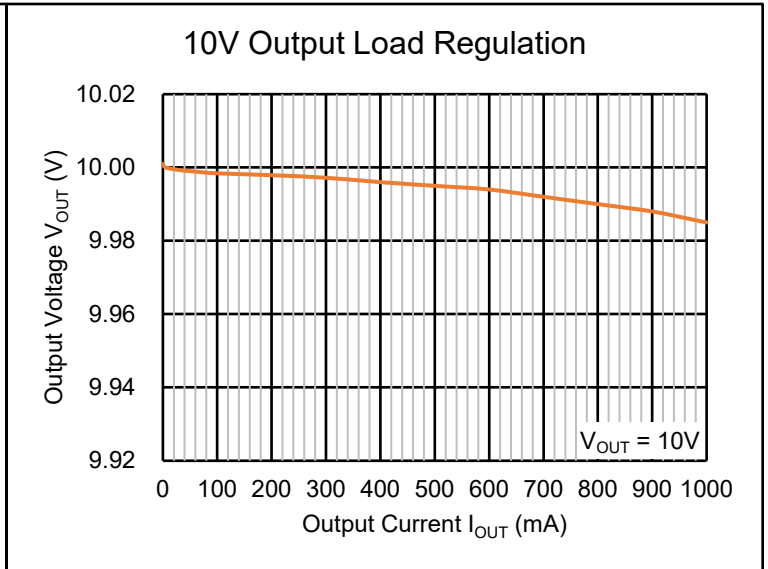
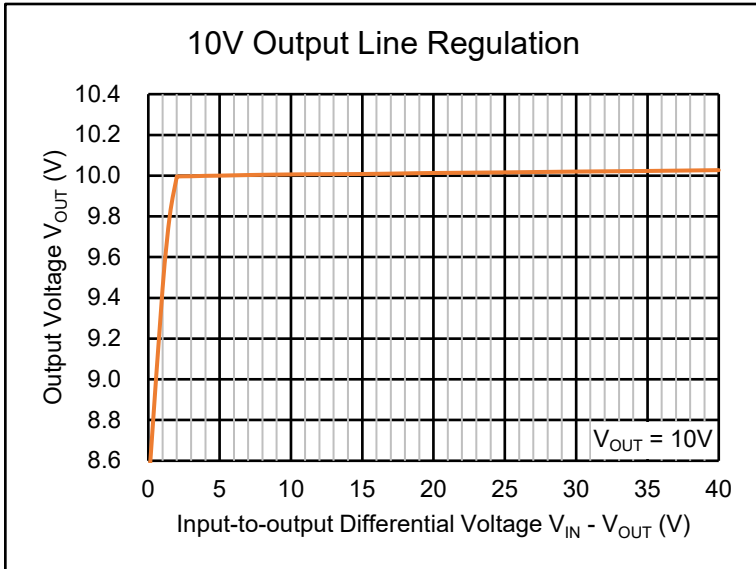
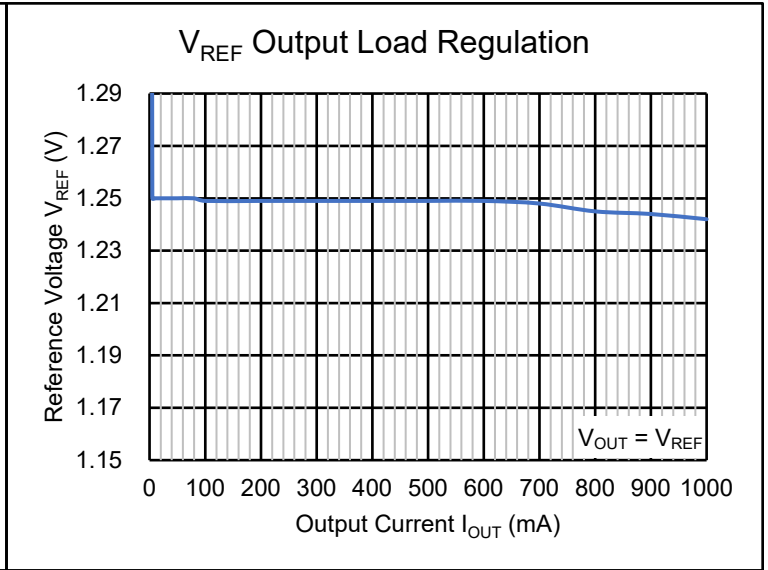
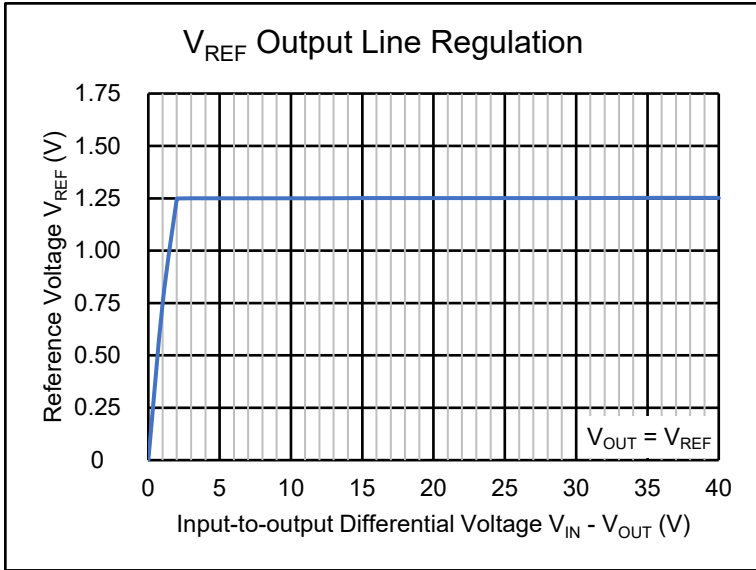

7 Specifications

7.5 Typical Characteristics (continued)

LM317D ($V_{IN} - V_{OUT} = 5V$, $I_{OUT} = 10mA$, $C_{IN} = 0.1\mu F$, $C_{OUT} = 1.0\mu F$, $T_A = 25^\circ C$, unless otherwise specified)

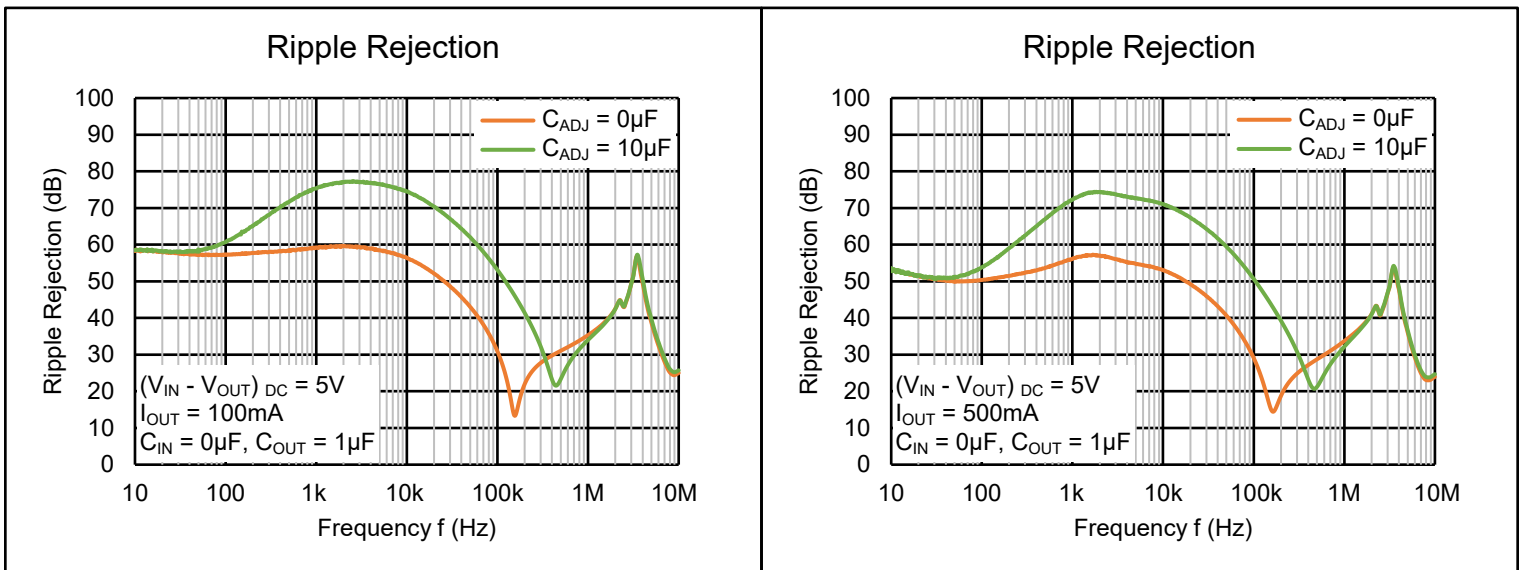
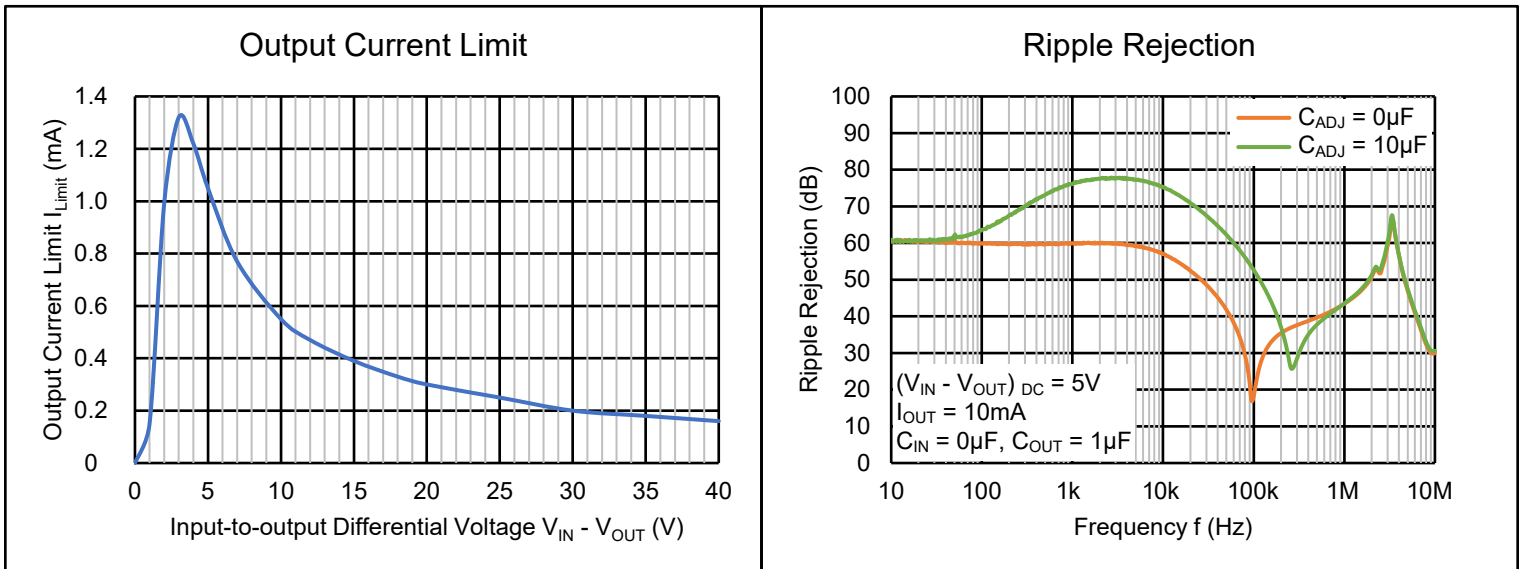
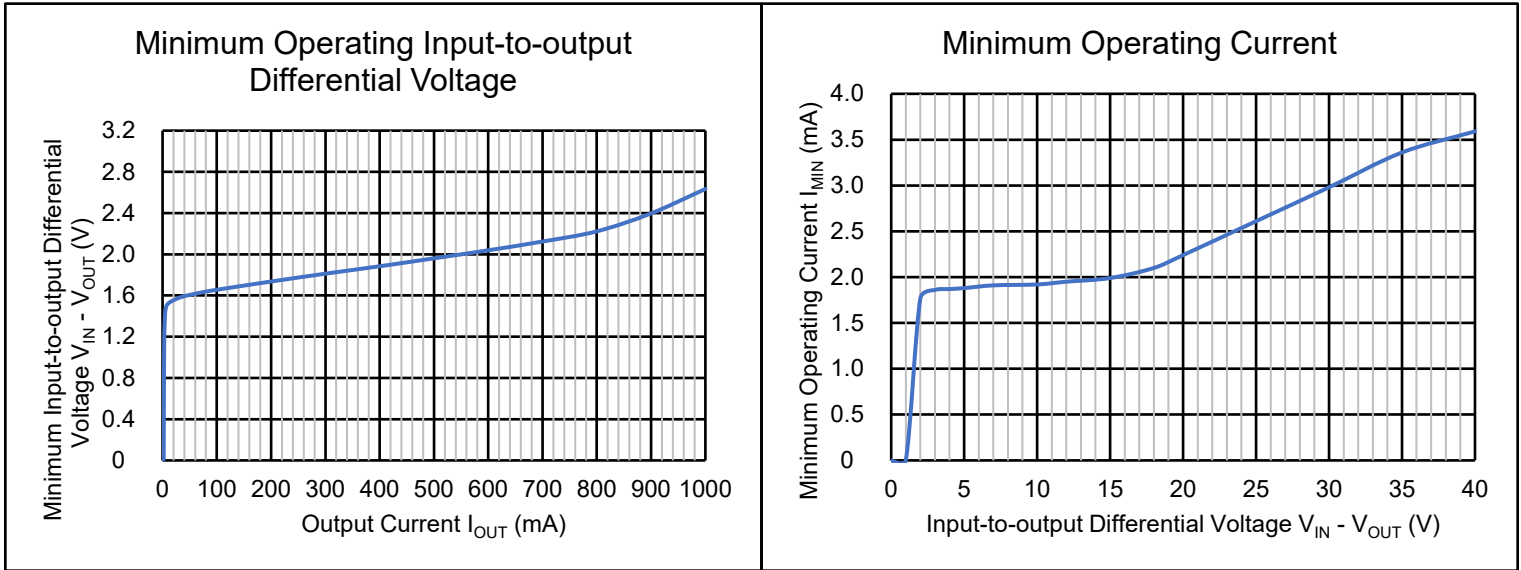

7 Specifications

7.5 Typical Characteristics (continued)

LM317D ($T_A = 25^\circ\text{C}$, unless otherwise specified)

Load Transient

$V_{OUT} = 10\text{V}$, $V_{IN} - V_{OUT} = 5\text{V}$, $I_{OUT} = 0 \sim 1\text{A}$, $C_{IN} = 1.0\mu\text{F}$, $C_{OUT} = 1.0\mu\text{F}$, **CH₂: V_{OUT}** , **CH₄: I_{OUT}**

$C_{ADJ} = 0\mu\text{F}$

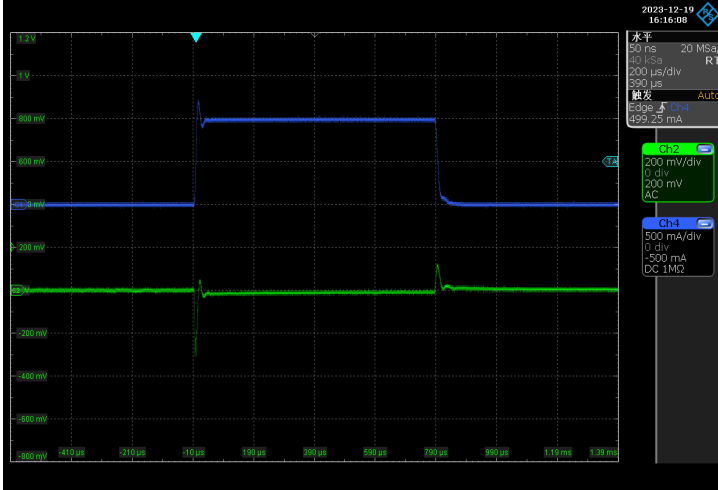

$C_{ADJ} = 10\mu\text{F}$

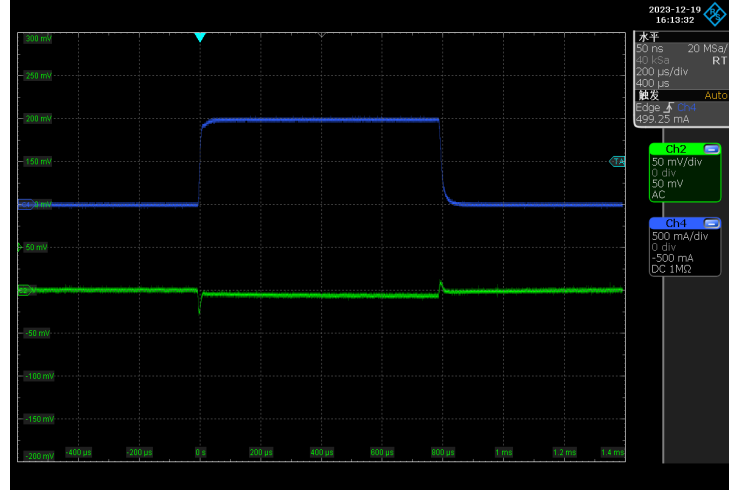

Power up Response

$V_{OUT} = 10\text{V}$, $V_{IN} = 0 \sim 15\text{V}$, $C_{IN} = 1.0\mu\text{F}$, $C_{OUT} = 1.0\mu\text{F}$, $C_{ADJ} = 10\mu\text{F}$, **CH₁: V_{IN}** , **CH₂: V_{OUT}**

$I_{OUT} = 10\text{mA}$

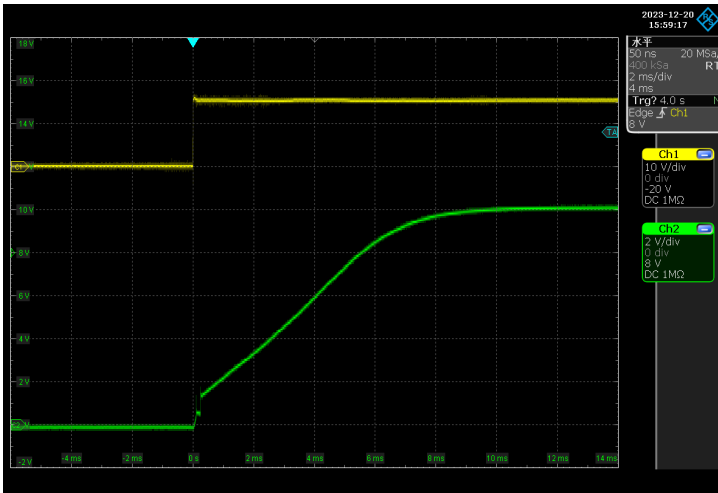

$I_{OUT} = 500\text{mA}$

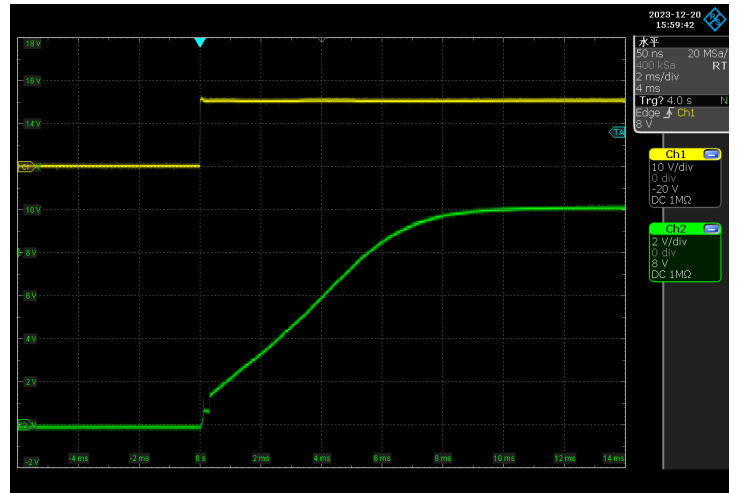

8 Detailed Description

8.1 Description

The LM317D is a three terminal positive voltage regulator with adjustable output. By setting two peripheral resistors, the output voltage range of the device can be set from 1.25V to 37V, and the current up to 1.0A can be provided. The LM317D integrates current limiting, thermal overload protection and safe operation area protection internally, and corresponding capacitors can be added to improve transient response. Therefore, the device is very easy to use, which is difficult to achieve with a standard three terminal regulator.

8.2 Representative Schematic Diagram

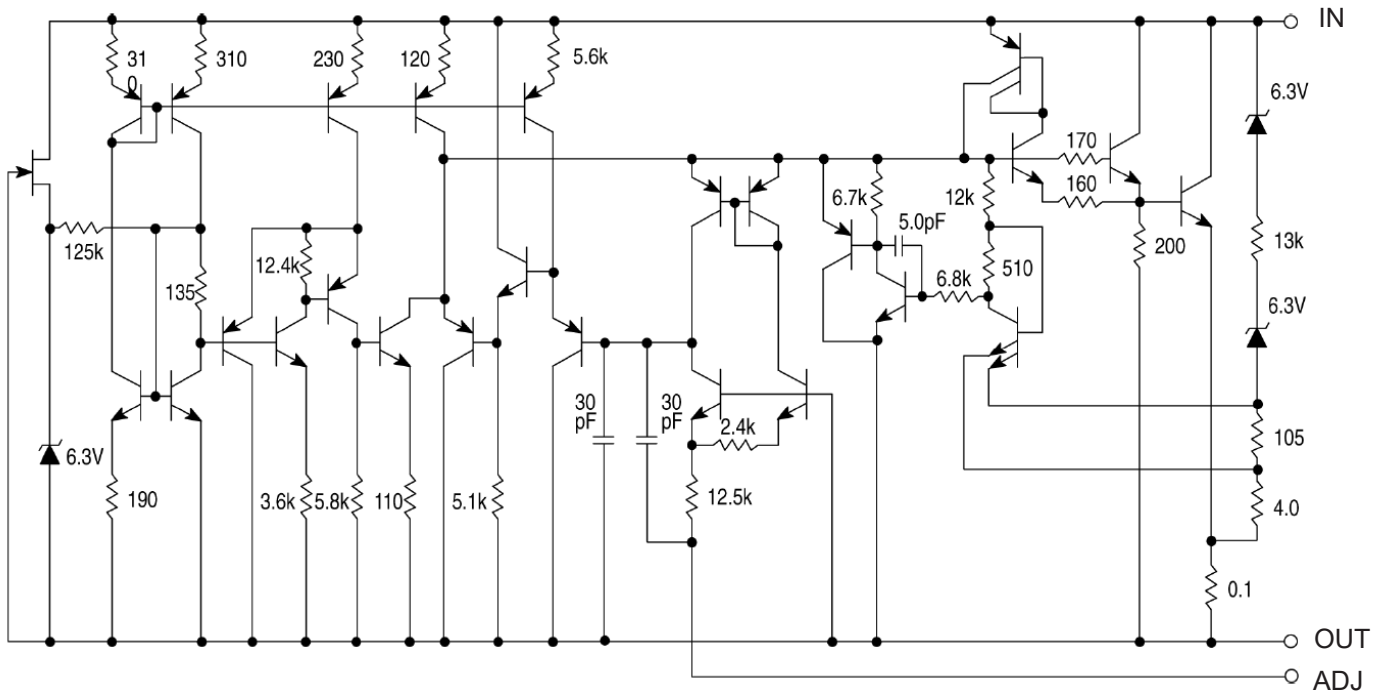

LM317D contains 29 transistors.

8.3 Feature Description

Comprehensive Overload Protection

The LM317D is internally integrated with current limit and thermal shutdown protection. When the output current is large or the junction temperature is higher than the rated range of the data sheet to a certain extent, the LM317D will enter the protection state and shut down the device to prevent accidental damage to the device. After the output current or junction temperature decreases to a certain extent, the LM317D will be released from the protection state and output normally.

When the output is short circuited, the LM317D will also enter the protection state and maintain the current at a low level. If the short circuit is removed, the LM317D will release the protection status and output normally.

8 Detailed Description

8.3 Feature Description (continued)

Minimum Operating Current

The LM317D needs to provide bias current between OUT and ADJ to make the device work normally. The load or feedback must consume this minimum current for regulation, otherwise the output may be too high. Refer to the *Electrical Characteristics* for the minimum load current required to maintain regulation.

Minimum Operating Voltage Difference

The LM317D requires a voltage difference ($V_{IN} - V_{OUT}$) of at least 3V between input and output before it can operate in the normal working state, otherwise the device may not maintain the normal output state.

Programmable Feedback

The device will provide 1.25V (typical value) bias voltage between OUT and ADJ, and the output voltage or current (not both) can be easily programmed through external resistance. For current regulation applications, a single resistor with a resistance value of $(1.25V / I_{OUT})$ and a rated power greater than $((1.25V)^2 / R)$ shall be used. For voltage regulation applications, two resistors set the output voltage.

Normal Operation

The LM317D is a three terminal positive voltage regulator with adjustable output. During normal operation, the LM317D will maintain a reference voltage V_{REF} of 1.25V between OUT and ADJ. This reference voltage V_{REF} is converted from R_1 to programming current I_{PROG} (see Figure 8-1), which flows to ground through R_2 . The regulated output voltage is given by the following formula:

$$V_{OUT} = V_{REF} \times \left(1 + \frac{R_2}{R_1}\right) + I_{ADJ} \times R_2$$

As an error term in the formula, I_{ADJ} is designed to be less than 100 μ A and keep constant. Therefore, in most applications, this item can be negligible.

Since the LM317D requires the minimum operating current and the minimum operating voltage difference for normal operation, the corresponding conditions shall be met in the circuit design.

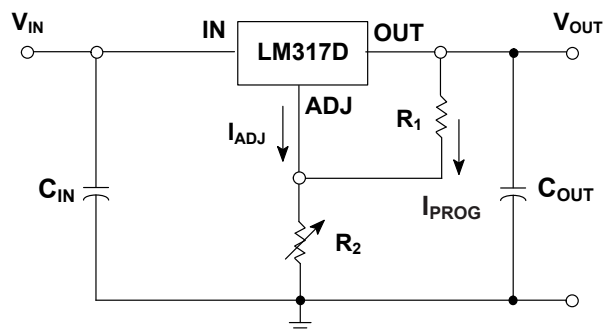

Figure 8-1. Basic Normal Operation

9 Application and Implementation

9.1 Application Information

Load Regulation

Following the following design recommendations can help the LM317D achieve better load regulation. The switching resistor R_1 shall be connected as close to the voltage regulator as possible to minimize the voltage drop of the line effectively connected in series with the reference voltage and avoid poor adjustment rate. The grounding terminal of R_2 can be returned close to the load grounding terminal to provide remote grounding sampling and improve the load adjustment rate.

External Capacitors

A $0.1\mu\text{F}$ disc or $1.0\mu\text{F}$ tantalum input bypass capacitor C_{IN} is recommended to reduce the sensitivity to input line impedance. The adjustment terminal may be bypassed to ground to improve ripple rejection.

A C_{ADJ} of $10\mu\text{F}$ (between ADJ and GND) is recommended to improve ripple rejection. It prevents amplification of the ripple as the output voltage is adjusted higher.

Although the LM317D is stable with no output capacitance, like any feedback circuit, certain values of external capacitance can cause excessive ringing. An output capacitance C_{OUT} in the form of a $1.0\mu\text{F}$ tantalum or $25\mu\text{F}$ aluminum electrolytic capacitor on the output swamps this effect and insures stability. The C_{IN} and C_{OUT} should be placed as close to the corresponding device pins as possible.

When the LM317D is used as a reference voltage source instead of a peripheral resistor, it is recommended to use an input capacitor of $1.0\mu\text{F}$ or more to obtain better voltage stability.

Protection Diodes

When external capacitors are used with any IC regulator it is sometimes necessary to add protection diodes to prevent the capacitors from discharging through low current points into the regulator. Figure 9-1 shows the LM317D with the recommended protection diodes for output voltages in excess of 25V or high capacitance values ($C_{OUT} > 25\mu\text{F}$, $C_{ADJ} > 10\mu\text{F}$). Diode D_1 prevents C_{OUT} from discharging through the IC during an input short circuit. Diode D_2 protects against capacitor C_{ADJ} discharging through the IC during an output short circuit. The combination of diodes D_1 and D_2 prevents C_{ADJ} from discharging through the IC during an input short circuit.

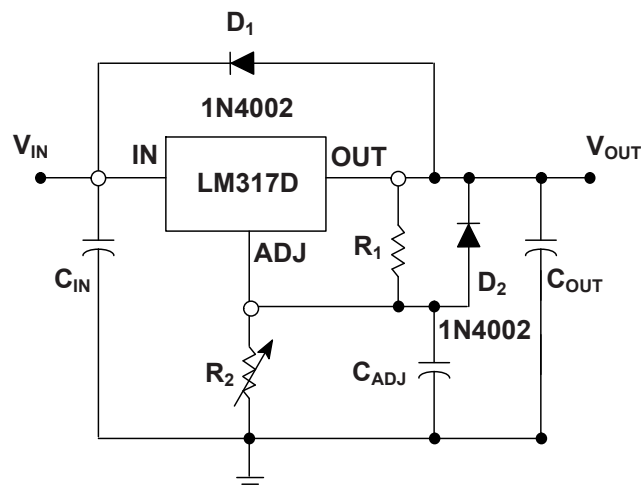

Figure 9-1. Voltage Regulator with Protection Diodes

9 Application and Implementation

9.2 System Example

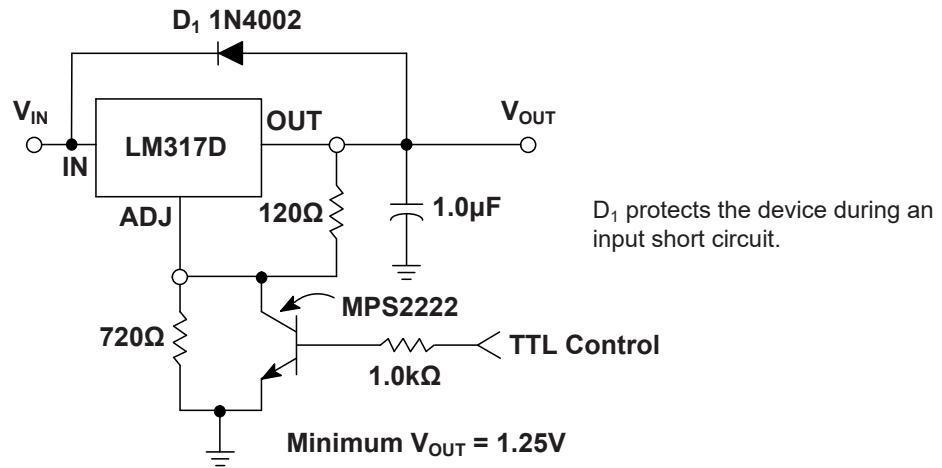

Figure 9-2. 5V Electronic Shutdown Regulator

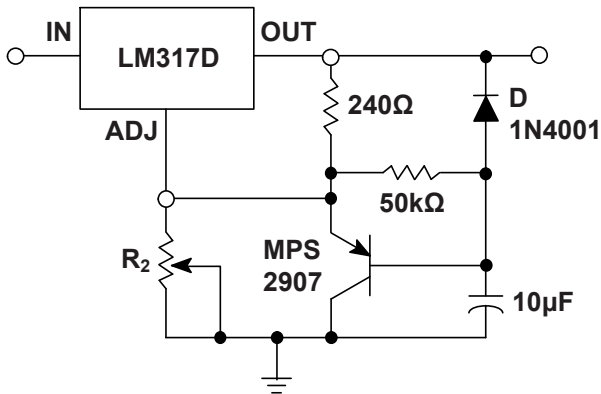

Figure 9-3. Slow Turn-On Regulator

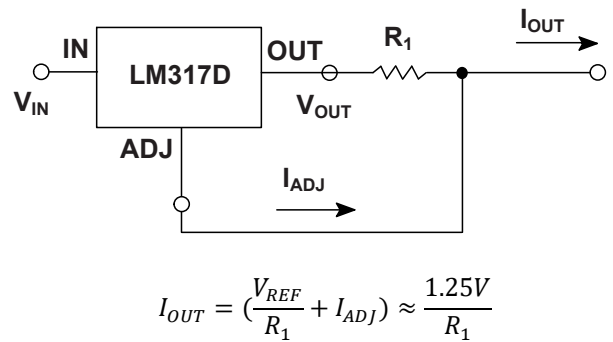

Figure 9-4. Current Regulator

9.3 Layout Guidelines

- It is recommended to use a bypass capacitor to bypass and ground the input terminals.
- The optimal location is closest to the input terminals of the device and the system GND. Pay attention to minimizing the loop area formed by the connection of bypass capacitors, input terminals, and system GND as much as possible.
- For operation at full load, it is recommended to use a wide trace length to eliminate $I \times R$ pressure drop and heat dissipation.

NOTE

The application information in this section is not part of the data sheet component specification, and JSCJ makes no commitment or statement to guarantee its accuracy or completeness. Customers are responsible for determining the rationality of corresponding components in their circuit design and making tests and verifications to ensure the normal realization of their circuit design.

10 Mechanical Information

10.1 SOT-223 Mechanical Information

SOT-223 Outline Dimensions

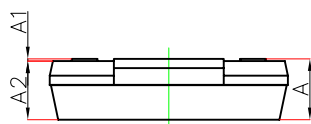
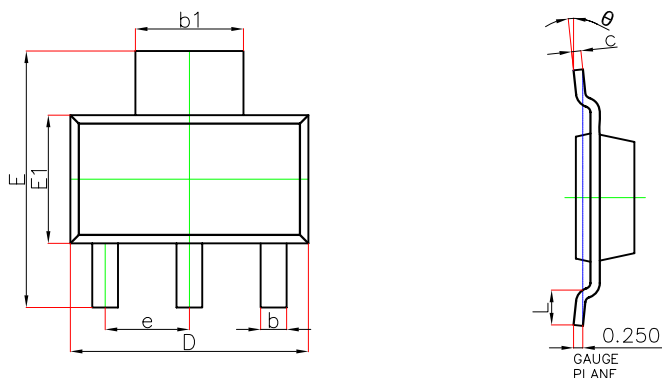

Symbol	Dimensions In Millimeters		Dimensions In Inches	
	Min.	Max.	Min.	Max.
A	—	1.800	—	0.071
A1	0.020	0.100	0.001	0.004
A2	1.500	1.700	0.059	0.067
b	0.660	0.840	0.026	0.033
b1	2.900	3.100	0.114	0.122
c	0.230	0.350	0.009	0.014
D	6.300	6.700	0.248	0.264
E	6.700	7.300	0.264	0.287
E1	3.300	3.700	0.130	0.146
e	2.300(BSC)		0.091(BSC)	
L	0.750	—	0.030	—
θ	0°	10°	0°	10°

SOT-223 Suggested Pad Layout

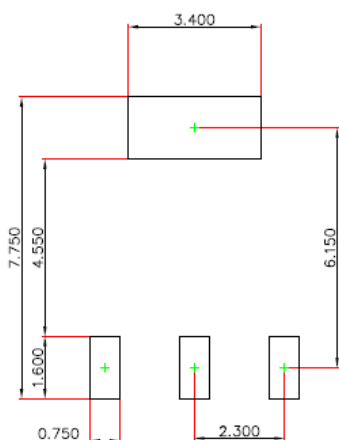

Note:

1. Controlling dimension: in millimeters.
2. General tolerance: $\pm 0.05\text{mm}$.
3. The pad layout is for reference purposes only.

10 Mechanical Information

10.2 TO-220-3L Mechanical Information

TO-220-3L Outline Dimensions

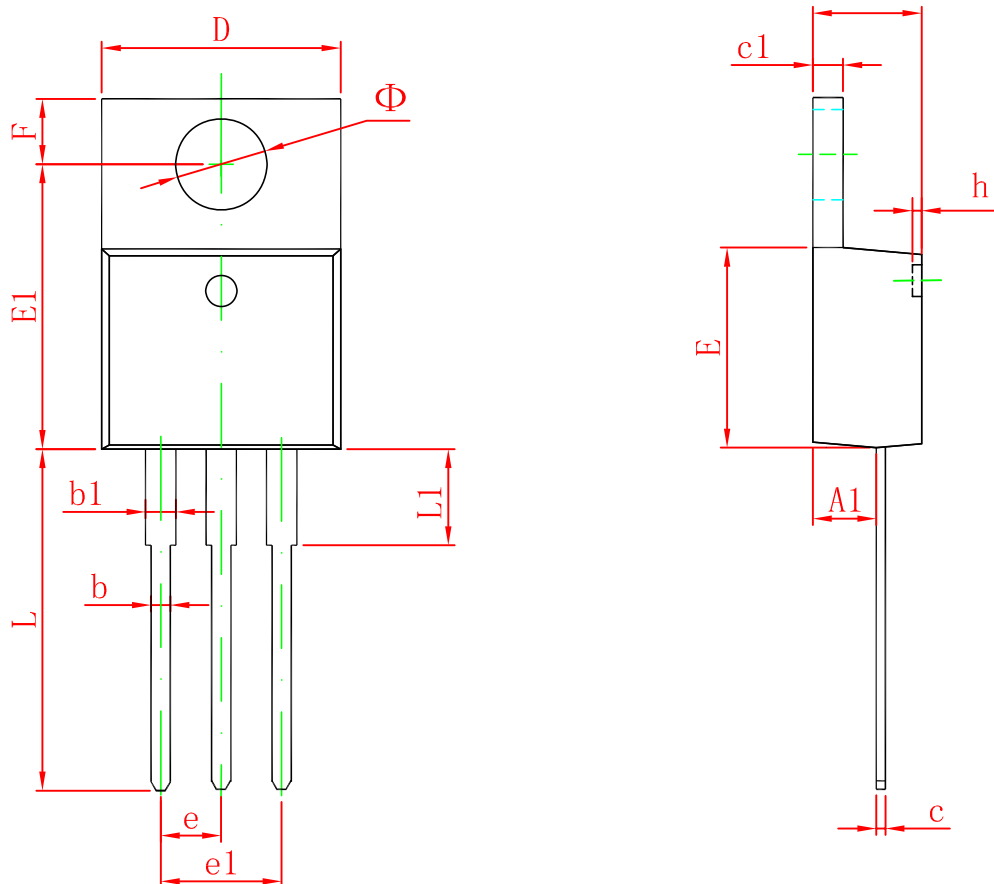

Symbol	Dimensions In Millimeters		Dimensions In Inches	
	Min	Max	Min	Max
A	4.470	4.670	0.176	0.184
A1	2.520	2.820	0.099	0.111
b	0.710	0.910	0.028	0.036
b1	1.170	1.370	0.046	0.054
c	0.310	0.530	0.012	0.021
c1	1.170	1.370	0.046	0.054
D	10.010	10.310	0.394	0.406
E	8.500	8.900	0.335	0.350
E1	12.060	12.460	0.475	0.491
e	2.540 TYP		0.100 TYP	
e1	4.980	5.180	0.196	0.204
F	2.590	2.890	0.102	0.114
h	0.000	0.300	0.000	0.012
L	13.400	13.800	0.528	0.543
L1	3.560	3.960	0.140	0.156
Φ	3.735	3.935	0.147	0.155

10 Mechanical Information

10.3 TO-252-2L Mechanical Information

TO-252-2L Outline Dimensions

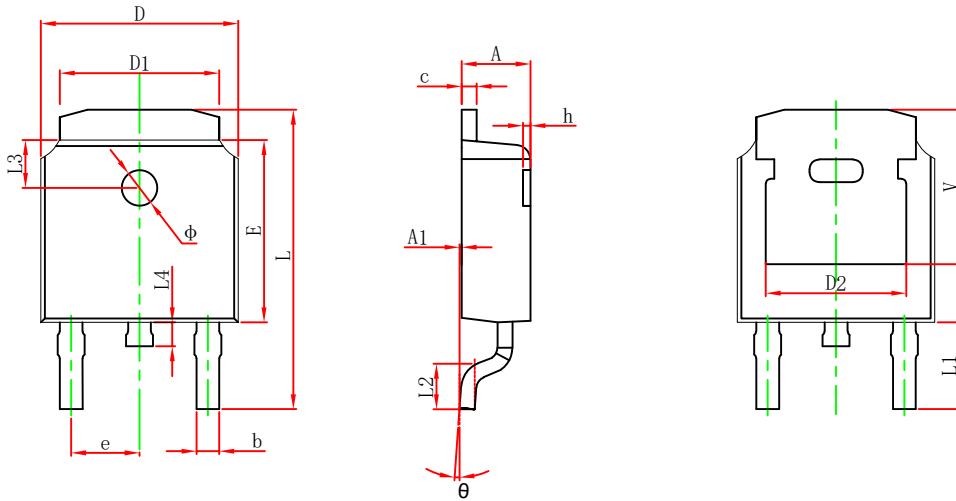

Symbol	Dimensions In Millimeters		Dimensions In Inches	
	Min.	Max.	Min.	Max.
A	2.200	2.400	0.087	0.094
A1	0.000	0.127	0.000	0.005
b	0.635	0.770	0.025	0.030
c	0.460	0.580	0.018	0.023
D	6.500	6.700	0.256	0.264
D1	5.100	5.460	0.201	0.215
D2	4.830 REF.		0.190 REF.	
E	6.000	6.200	0.236	0.244
e	2.186	2.386	0.086	0.094
L	9.712	10.312	0.382	0.406
L1	2.900 REF.		0.114 REF.	
L2	1.400	1.700	0.055	0.067
L3	1.600 REF.		0.063 REF.	
L4	0.600	1.000	0.024	0.039
phi	1.100	1.300	0.043	0.051
theta	0°	8°	0°	8°
h	0.000	0.300	0.000	0.012
V	5.250 REF.		0.207 REF.	

TO-252-2L Suggest Pad Layout

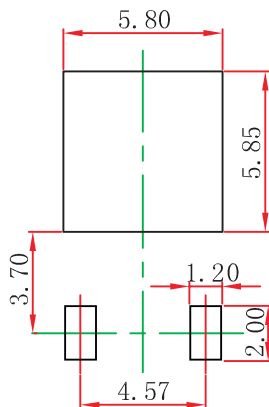

Note:

1. Controlling dimension: in millimeters.
2. General tolerance: ±0.05mm.
3. The pad layout is for reference purposes only.

10 Mechanical Information

10.4 TO-263-2L Mechanical Information

TO-263-2L Outline Dimensions

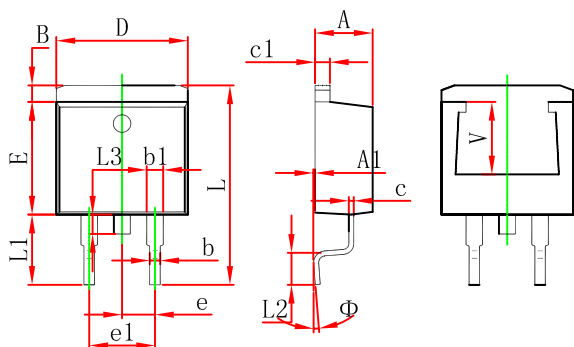

Symbol	Dimensions In Millimeters		Dimensions In Inches	
	Min.	Max.	Min.	Max.
A	4.470	4.670	0.176	0.184
A1	0.000	0.150	0.000	0.006
B	1.120	1.420	0.044	0.056
b	0.710	0.910	0.028	0.036
b1	1.170	1.370	0.046	0.054
c	0.310	0.530	0.012	0.021
c1	1.170	1.370	0.046	0.054
D	10.010	10.310	0.394	0.406
E	8.500	8.900	0.335	0.350
e	2.540 TYP.		0.100 TYP.	
e1	4.980	5.180	0.196	0.204
L	14.940	15.500	0.588	0.610
L1	4.950	5.450	0.195	0.215
L2	2.340	2.740	0.092	0.108
L3	1.300	1.700	0.051	0.067
Φ	0°	8°	0°	8°
V	5.600 REF.		0.220 REF.	

TO-263-2L Suggest Pad Layout

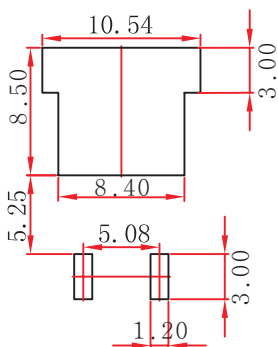

Note:

1. Controlling dimension: in millimeters.
2. General tolerance: ±0.05mm.
3. The pad layout is for reference purposes only.

11 Packaging Information

11.1 SOT-223 Tape and Reel Information

SOT-223 Embossed Carrier Tape

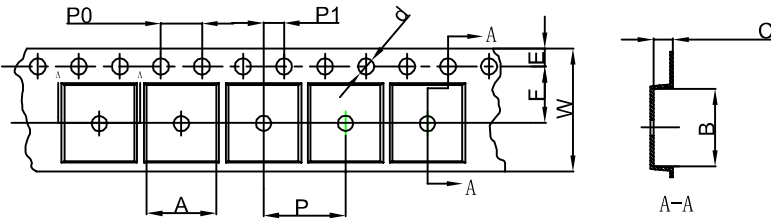

Packaging Description:

SOT-223 parts are shipped in tape. The carrier tape is made from a dissipative (carbon filled) polycarbonate resin. The cover tape is a multilayer film (Heat Activated Adhesive in nature) primarily composed of polyester film, adhesive layer, sealant, and anti-static sprayed agent. These reeled parts in standard option are shipped with 2,500 units per 13" or 33.0cm diameter reel. The reels are clear in color and is made of polystyrene plastic (anti-static coated),

Dimensions are in millimeter										
Pkg type	A	B	C	d	E	F	P0	P	P1	W
SOT-223	6.765	7.335	1.88	Ø1.50	1.75	5.50	4.00	8.00	2.00	12.00

SOT-223 Tape Leader and Trailer

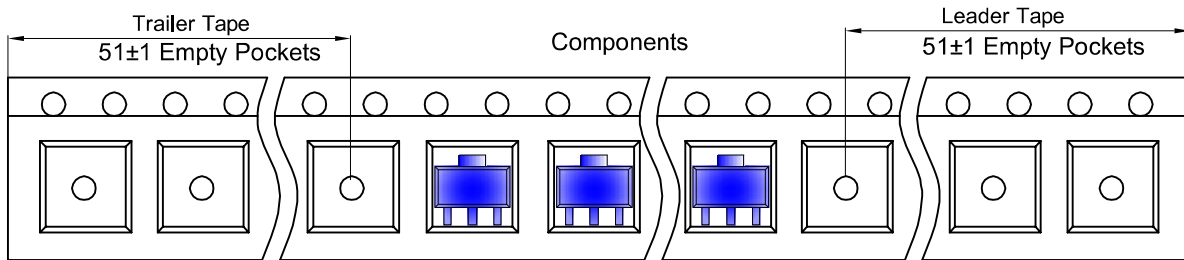

SOT-223 Reel

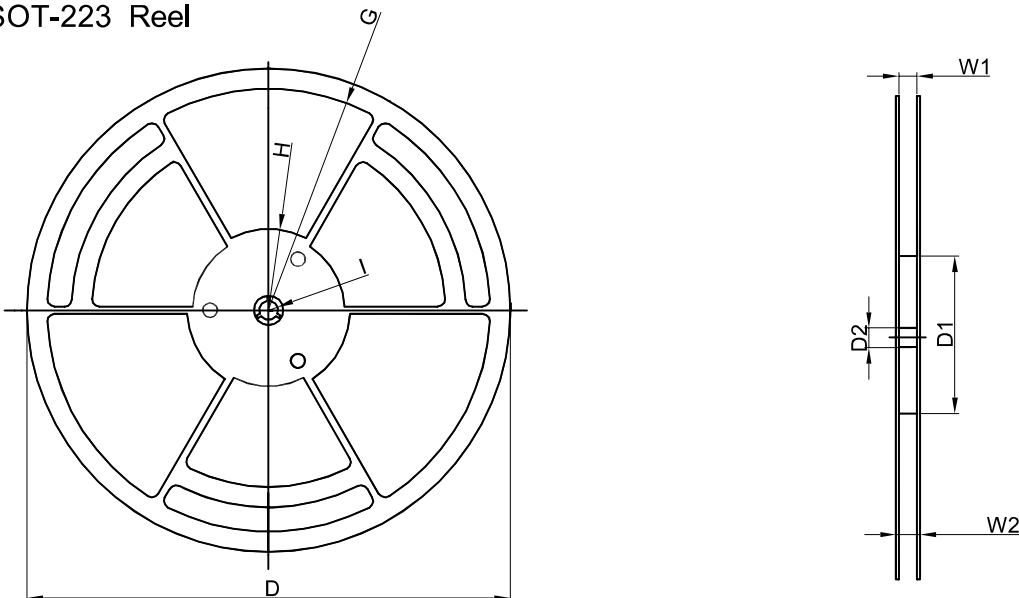

Dimensions are in millimeter								
Reel Option	D	D1	D2	G	H	I	W1	W2
13" Dia	φ330.00	100.00	13.00	R151.00	R56.00	R6.50	12.40	17.60

Reel	Reel Size	Box	Box Size (mm)	Carton	Carton Size (mm)
2,500 pcs	13 inch	5,000 pcs	360×360×65	25,000 pcs	378×358×382

11 Packaging Information

11.2 TO-252-2L Tape and Reel Information

TO-252-2L Embossed Carrier Tape

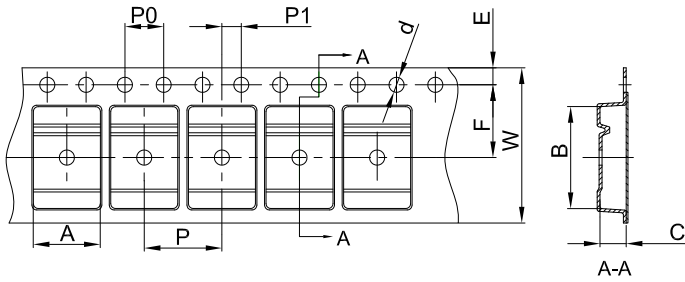

Packaging Description:
 TO-252 parts are shipped in tape. The carrier tape is made from a dissipative (carbon filled) polycarbonate resin. The cover tape is a multilayer film (Heat Activated Adhesive in nature) primarily composed of polyester film, adhesive layer, sealant, and anti-static sprayed agent. These reeled parts in standard option are shipped with 25,00 units per 13" or 33.0 cm diameter reel. The reels are clear in color and is made of polystyrene plastic (anti-static coated).

Dimensions are in millimeter										
Pkg type	A	B	C	d	E	F	P0	P	P1	W
TO-252	6.90	10.50	2.70	Ø1.55	1.75	7.50	4.00	8.00	2.00	16.00

TO-252-2L Tape Leader and Trailer

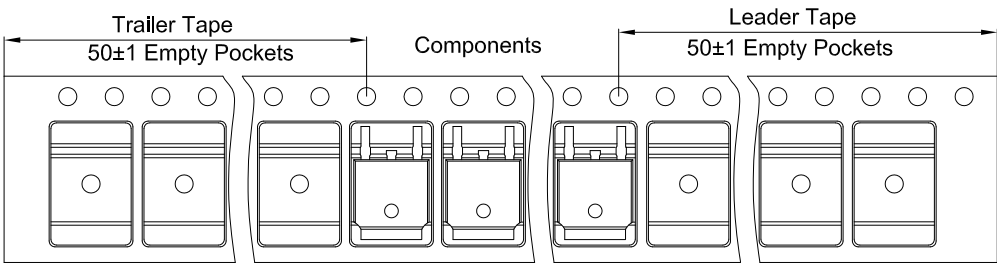

TO-252-2L Reel

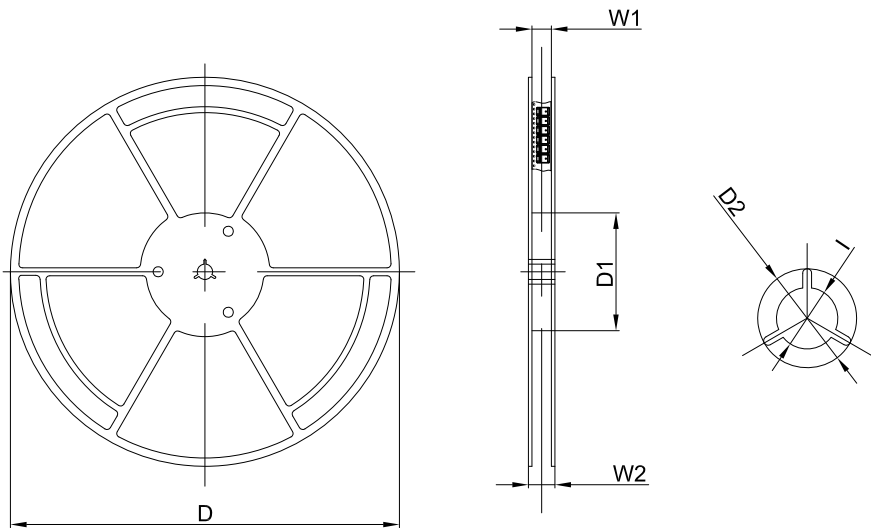

Dimensions are in millimeter						
Reel Option	D	D1	D2	W1	W2	I
13" Dia	330.00	100.00	Ø21.00	16.40	21.00	Ø13.00

REEL	Reel Size	Box	Box Size(mm)	Carton	Carton Size(mm)	G.W.(kg)
2,500 pcs	13inch	2,500 pcs	340×336×29	25,000 pcs	353×346×365	

11 Packaging Information

11.3 TO-263-2L Tape and Reel Information

TO-263-2L Embossed Carrier Tape

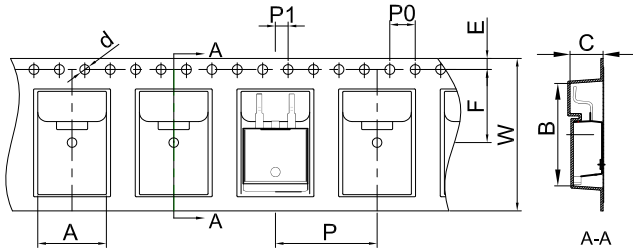

Packaging Description:
 TO-263-2L parts are shipped in tape. The carrier tape is made from a dissipative (carbon filled) polycarbonate resin. The cover tape is a multilayer film (Heat Activated Adhesive in nature) primarily composed of polyester film, adhesive layer, sealant, and anti-static sprayed agent. These reeled parts in standard option are shipped with 800 units per 13" or 33.0 cm diameter reel. The reels are clear in color and is made of polystyrene plastic (anti-static coated).

Dimensions are in millimeter										
Pkg type	A	B	C	d	E	F	P0	P	P1	W
TO-263-2L	10.80	16.13	5.21	Ø1.55	1.75	11.50	4.00	16.00	2.00	24.00

TO-263-2L Tape Leader and Trailer

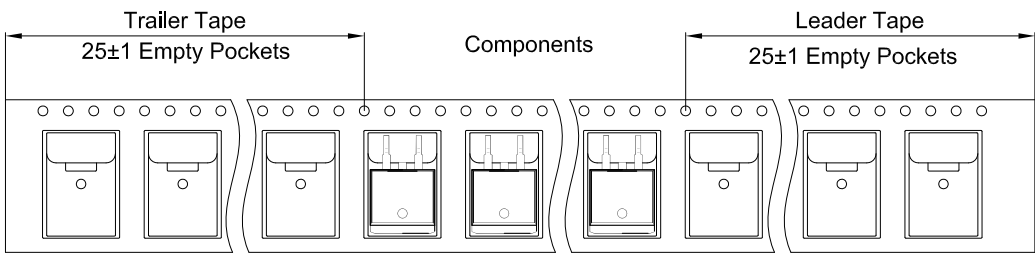

TO-263-2L Reel

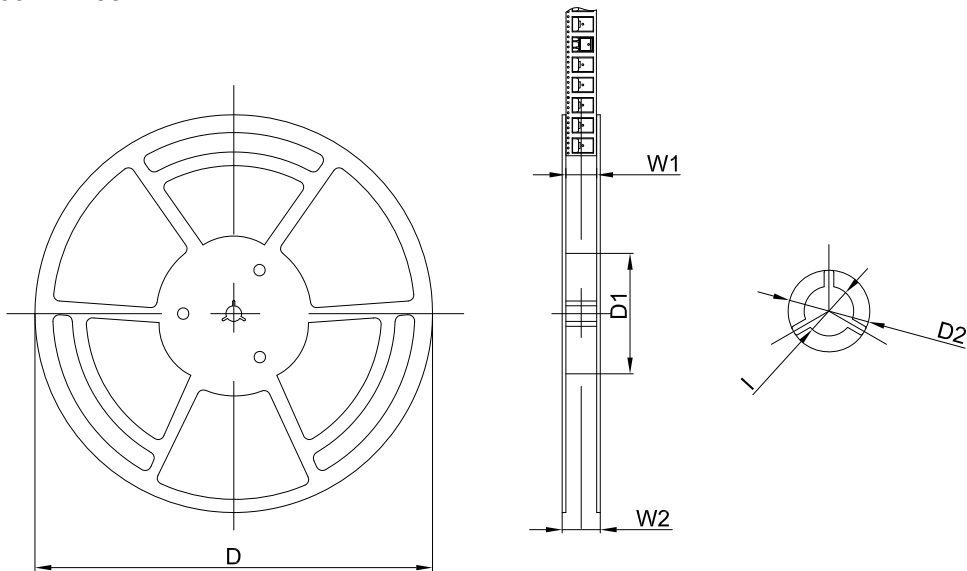

Dimensions are in millimeter						
Reel Option	D	D1	D2	W1	W2	I
13" Dia	Ø330.00	100.00	Ø21.00	24.4	30.4	Ø13.00

REEL	Reel Size	Box	Box Size(mm)	Carton	Carton Size(mm)	G.W.(kg)
800 pcs	13 inch	800 pcs	340×336×36	8,000 pcs	400×353×365	

12 Notes and Revision History

12.1 Associated Product Family and Others

To view other products of the same type or IC products of other types, click the official website of JSCJ -- <https://www.jscj-elec.com> for more details.

12.2 Notes

Electrostatic Discharge Caution



This IC may be damaged by ESD. Relevant personnel shall comply with correct installation and use specifications to avoid ESD damage to the IC. If appropriate measures are not taken to prevent ESD damage, the hazards caused by ESD include but are not limited to degradation of integrated circuit performance or complete damage of integrated circuit. For some precision integrated circuits, a very small parameter change may cause the whole device to be inconsistent with its published specifications.

12.3 Revision History

October, 2023: released LM317D rev - 1.0.

DISCLAIMER

IMPORTANT NOTICE, PLEASE READ CAREFULLY

The information in this data sheet is intended to describe the operation and characteristics of our products. JSCJ has the right to make any modification, enhancement, improvement, correction or other changes to any content in this data sheet, including but not limited to specification parameters, circuit design and application information, without prior notice.

Any person who purchases or uses JSCJ products for design shall: 1. Select products suitable for circuit application and design; 2. Design, verify and test the rationality of circuit design; 3. Procedures to ensure that the design complies with relevant laws and regulations and the requirements of such laws and regulations. JSCJ makes no warranty or representation as to the accuracy or completeness of the information contained in this data sheet and assumes no responsibility for the application or use of any of the products described in this data sheet.

Without the written consent of JSCJ, this product shall not be used in occasions requiring high quality or high reliability, including but not limited to the following occasions: medical equipment, military facilities and aerospace. JSCJ shall not be responsible for casualties or property losses caused by abnormal use or application of this product.

Official Website: www.jscj-elec.com

Copyright © JIANGSU CHANGJING ELECTRONICS TECHNOLOGY CO., LTD.