

LM321E Operational Amplifiers

1 Introduction

The LM321E brings performance and economy to low power systems. With a high unity gain frequency and a guaranteed $0.4V/\mu s$ slew rate, the quiescent current is only $200\mu A$ /amplifier (5V). The input common mode range includes ground and therefore the device is able to operate in single supply applications as well as in dual supply applications. It is also capable of comfortably driving large capacitive loads. The LM321E is available in the SOT package. Overall the LM321E is a low power, wide supply range performance op amp that can be designed into a wide range of applications at an economical price without sacrificing valuable board space.

2 Applications

- Computer and motherboard
- Household electric appliances
- Inverter circuit
- Motor control
- Multi-functional printer
- Power supply and portable charger
- Uninterruptible power supply (UPS)

3 Features

- Power Supply Range:
Single supply: 3.0 to 36V
Dual supplies: ± 1.5 to $\pm 18V$
- Low supply current: $200\mu A$
- Low Input Offset Voltage:
 $0.5mV$ (Typ.) at $25^\circ C$
- Low Input Bias Current:
 $15nA$ (Typ.) at $25^\circ C$
- Unity-gain Bandwidth: $1.0MHz$ (Typ.)
- Wide operating ambient temperature:
 $-40 \sim 85^\circ C$
- Internally frequency compensated for unity gain
- Common-mode input voltage range includes ground

4 Available Packages

PART NUMBER	PACKAGE
LM321E-M5N	SOT-23-5L

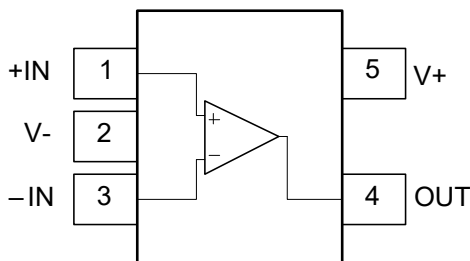

Pin Connections

5 Pin Configuration and Marking Information

5.1 Pin Configuration and Function

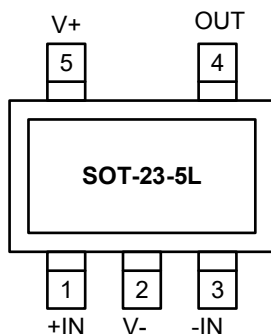
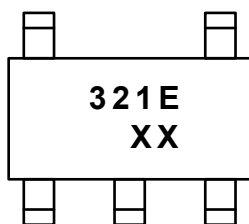

Figure 5-1. LM321E Pin Map

PIN NAME	LM321E	I / O	DESCRIPTION
	SOT23-5L		
IN+	1	I	Positive input of the operational amplifier
V-	2	-	Negative (lowest) supply or ground for single supply.
IN-	3	I	Negative input of the operational amplifier
OUT	4	O	Output of the operational amplifier
V+	5	-	Positive (highest) supply.

5.2 Marking Information



SOT-23-5L

"321E": Device number.

"XX": Code, indicates weekly record information.

6 Specifications

6.1 Absolute Maximum Ratings

(over operating ambient temperature range, unless otherwise specified)⁽¹⁾

CHARACTERISTIC		SYMBOL	VALUE	UNIT
Maximum power supply	Single supply	V_S	40	V
	Dual supplies		± 20	
Maximum differential input range ⁽²⁾		V_{ID}	-32 ~ 32	V
Maximum input range (either input)		V_{IN}	-0.3 ~ 40	V
Duration of output short circuit (one amplifier) to ground (or below) at $T_A = 25^\circ\text{C}$, $V_S \leq 15\text{V}$		t_{SC}	Continuous ⁽³⁾	s
Maximum junction temperature		$T_{J\text{MAX}}$	150	$^\circ\text{C}$
Storage temperature		T_{stg}	-65 ~ 150	$^\circ\text{C}$
Soldering temperature & time		T_{solder}	260 $^\circ\text{C}$, 10s	-

(1) Stresses beyond those listed under *Absolute Maximum Ratings* may cause permanent damage to the device. These are stress ratings only, which do not imply functional operation of the device at these or any other conditions beyond those indicated under *Recommended Operating Conditions*. Exposure to absolute-maximum rated conditions for extended periods may affect device reliability.

(2) Differential voltages are at $IN+$, with respect to $IN-$.

(3) Short circuits from outputs to V_S can cause excessive heating and eventual destruction. A heat sink may be required to keep the junction temperature below the absolute maximum. This depends on the power supply voltage and how many amplifiers are shorted. Thermal resistance varies with the amount of PC board metal connected to the package. The specified values are for short traces connected to the leads.

6.2 Recommend Operating Conditions

(over operating ambient temperature range, unless otherwise specified)

PARAMETER		SYMBOL	MIN.	NOM.	MAX.	UNIT
Power supply range	Single supply	V_S	3.0	-	36	V
	Dual supplies		± 1.5	-	± 18	
Common-mode voltage range		V_{CM}	$V-$	-	$(V+) - 2.0$	V
Operating ambient temperature	LM321E	T_A	-40	-	85	$^\circ\text{C}$

6 Specifications

6.3 ESD Ratings

ESD RATINGS			SYMBOL	VALUE	UNIT
Electrostatic discharge ⁽⁴⁾	Human body model	LM321E	V _{ESD-HBM}	1000	V

(4) ESD testing is conducted in accordance with the relevant specifications formulated by the Joint Electronic Equipment Engineering Commission (JEDEC). The human body model (HBM) electrostatic discharge test is based on the JESD22-A114D test standard, using a 100pF capacitor and discharging to each pin of the device through a resistance of 1.5kΩ.

6.4 Thermal Information

THERMAL METRIC ⁽⁵⁾	SYMBOL	SOT-23-5L	UNIT
Junction-to-ambient thermal resistance	R _{θJA}	250.3	°C/W
Junction-to-case thermal resistance	R _{θJC}	65.4	°C/W
Reference maximum power dissipation (continuous)	P _{D Ref}	0.40	W

(5) T_A = 25°C, measured on evaluation board with 1oz. copper traces of minimum pad size, all device outputs were active.

6 Specifications

6.5 Electrical Characteristics

LM321E ($V_S = (V+) - (V-) = 5.0V$, $T_A = 25^\circ C$, unless otherwise specified)

CHARACTERISTIC	SYMBOL	TEST CONDITIONS ⁽⁶⁾	MIN.	TYP.	MAX.	UNIT		
Offset Voltage								
Input offset voltage	V_{OS}	$V_S = 5.0$ to $30V$, $V_{CM} = 0V$, $V_{OUT} = 1.4V$	$T_A = 25^\circ C$	-	0.5	3.0	mV	
			Full range	-	-	5.0		
Input offset voltage vs power supply ($\Delta V_{IO} / \Delta V_S$)	PSRR	$V_S = 5.0$ to $30V$	65	100	-	dB		
Input offset voltage drift	dV_{OS} / dT	-	Full range	-	4.0	-	$\mu V / ^\circ C$	
Channel separation	CS	$f = 1k$ to $20kHz$	-	120	-	dB		
Input Voltage Range								
Common-mode voltage range	V_{CM}	$V_S = 5.0$ to $30V$	$T_A = 25^\circ C$	V-	-	$(V+) - 1.5$	V	
			Full range	V-	-	$(V+) - 2.0$		
Common-mode rejection ratio	CMRR	$V_S = 5.0$ to $30V$; $V_{CM} = 0V$	70	80	-	dB		
Power Supply								
Quiescent current both amplifiers	I_Q	$V_S = 5.0V$, $R_L = \infty$	-	0.2	0.5	mA		
		$V_S = 30V$, $R_L = \infty$	-	0.25	0.55	mA		
Input Bias Current								
Input bias current	I_{IB}	$V_{CM} = 0V$, $V_{OUT} = 1.4V$	$T_A = 25^\circ C$	-	± 15	± 150	nA	
			Full range	-	-	± 250		
Input offset current	I_{OS}	$V_{CM} = 0V$, $V_{OUT} = 1.4V$	$T_A = 25^\circ C$	-	± 3.0	± 30	nA	
			Full range	-	-	± 150		
Frequency Response								
Gain bandwidth product	GBW	-	-	1.0	-	MHz		
Slew rate	SR	$G = +1$	-	0.4	-	V / μs		
Output								
Voltage output swing from rail	V_{OUT}	$V_S = 30V$, $R_L \geq 10k\Omega$	Positive rail	$T_A = 25^\circ C$	-	2.0	3.0	V
				Full range	-	2.5	-	
		$V_S = 30V$, $R_L = 2k\Omega$	Positive rail	$T_A = 25^\circ C$	-	3.0	4.0	
				Full range	-	3.5	-	
$V_S = 5.0V$, $R_L = 10k\Omega$	Negative rail	Full range	-	5.0	20	mV		
Output current	I_{OUT}	$V_S = 15V$, $V_{OUT} = 0V$, $V_{ID} = 1V$, Source		20	40	-	mA	
		$V_S = 15V$, $V_{OUT} = 2V$, $V_{ID} = -1V$, Sink		10	15	-	mA	
		$V_{OUT} = 0.2V$, $V_{ID} = -2V$		12	50	-	μA	
Short-circuit current	I_{SC}	$V_S = 15V$	-	± 40	± 60	mA		
Open-loop Gain								
Open-loop voltage gain	A_{OL}	$V_S = 15V$, $V_{OUT} = 1.0$ to $11V$, $R_L \geq 2k\Omega$	25	100	-	V / mV		

6 Specifications

6.5 Electrical Characteristics (continued)

Note:

(6) All characteristics are measured under open-loop conditions, with zero common-mode input voltage, unless otherwise specified. All typical values are $T_A = 25^\circ\text{C}$. For the LM321E, "Full range" refers to T_A ranging from -40 to 85°C .

6.6 Typical Characteristics

LM321E ($V_S = (V+) - (V-) = 5.0\text{V}$, $V_{CM} = 0\text{V}$, $R_L = \infty$, $T_A = 25^\circ\text{C}$, unless otherwise specified)

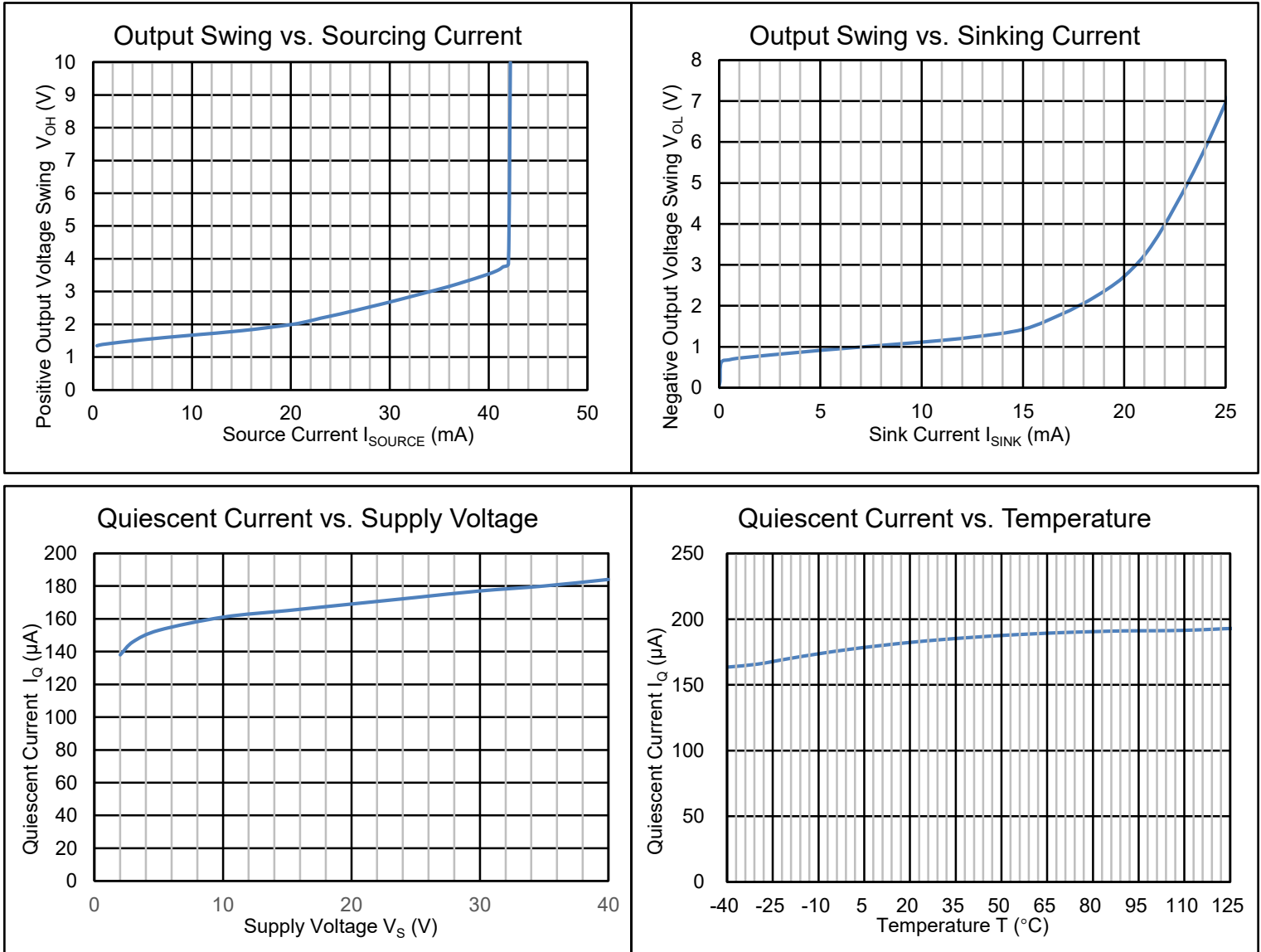

6 Specifications

6.6 Typical Characteristics (continued)

LM321E ($V_S = (V+) - (V-) = 5.0V$, $V_{CM} = 0V$, $R_L = \infty$, $T_A = 25^\circ C$, unless otherwise specified)

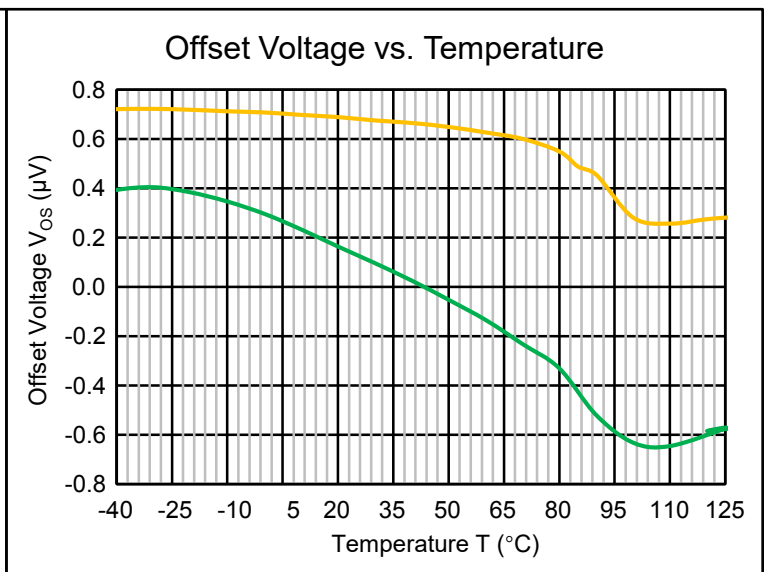
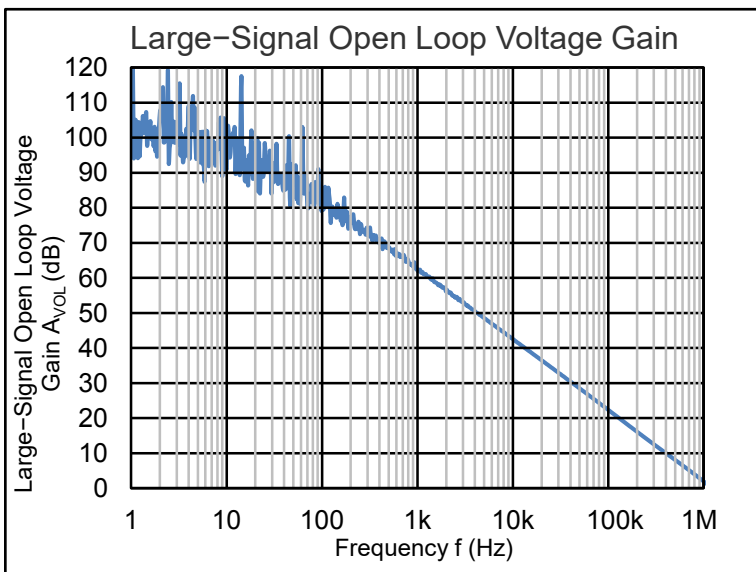
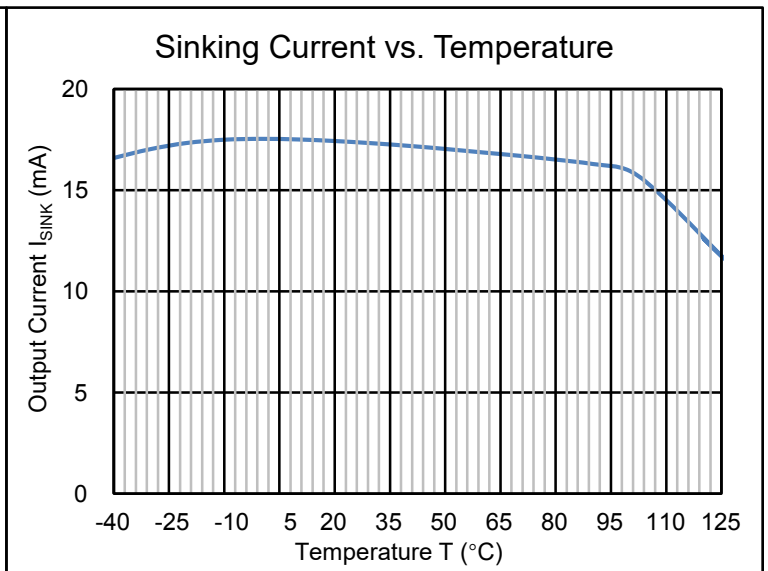
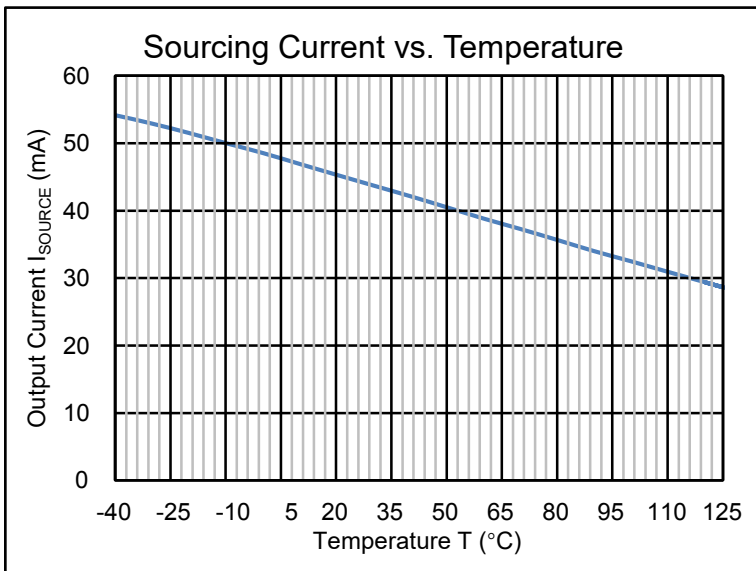
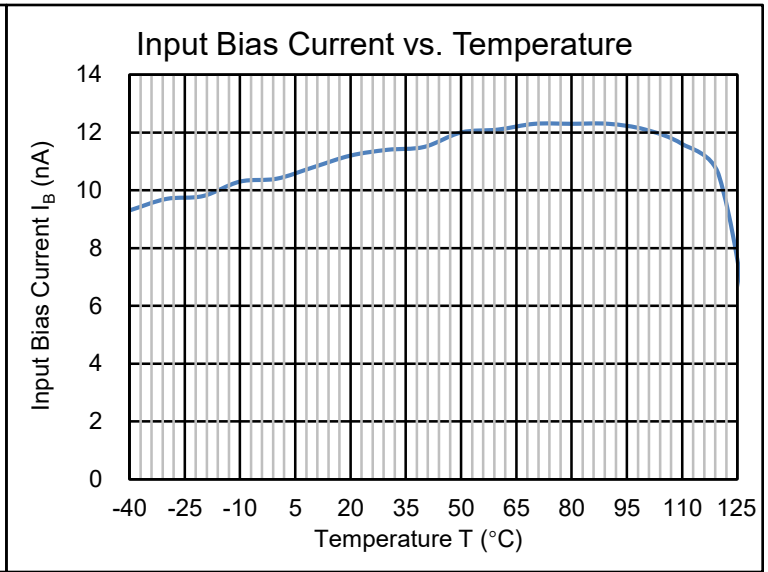
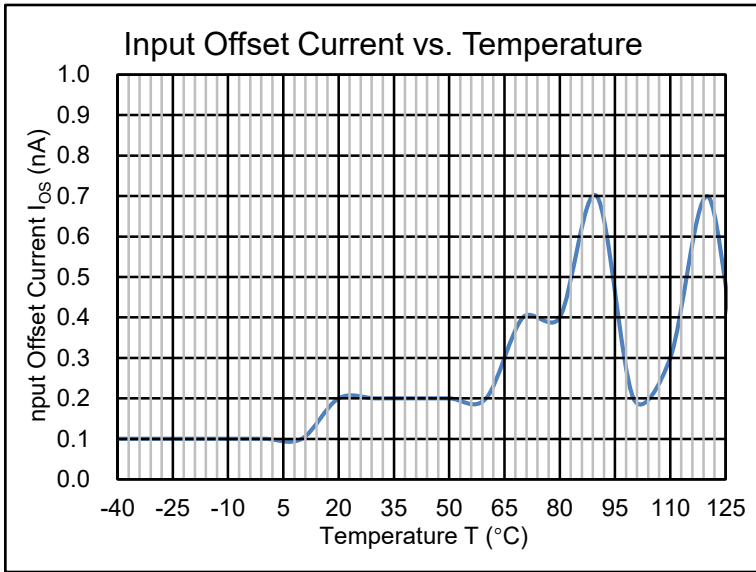

6 Specifications

6.6 Typical Characteristics (continued)

LM321E ($V_S = (V+) - (V-) = 5.0V$, $V_{CM} = 0V$, $R_L = \infty$, $T_A = 25^\circ C$, unless otherwise specified)

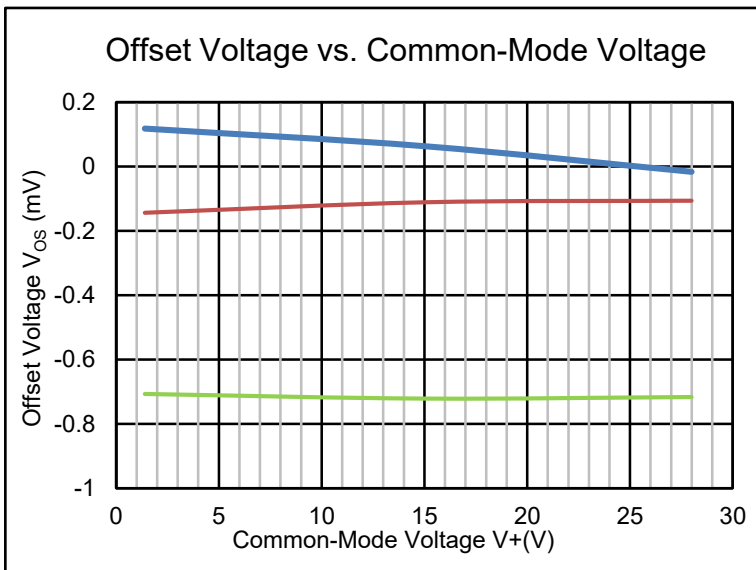
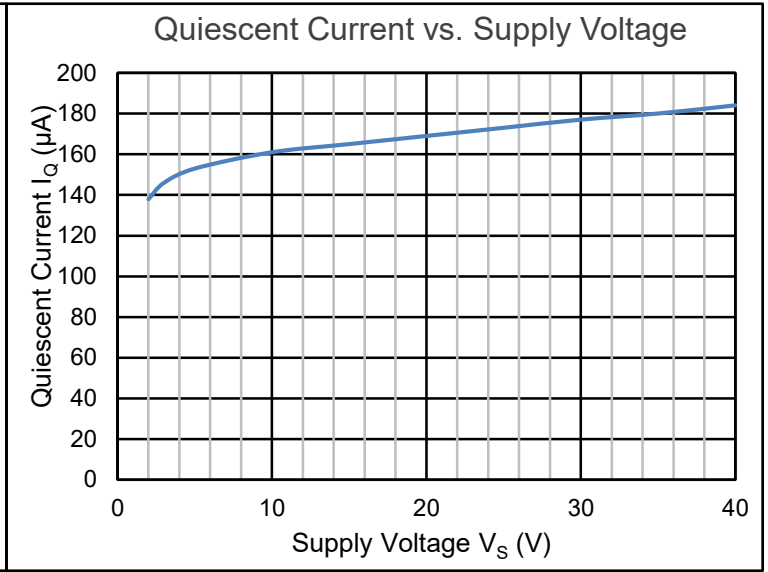
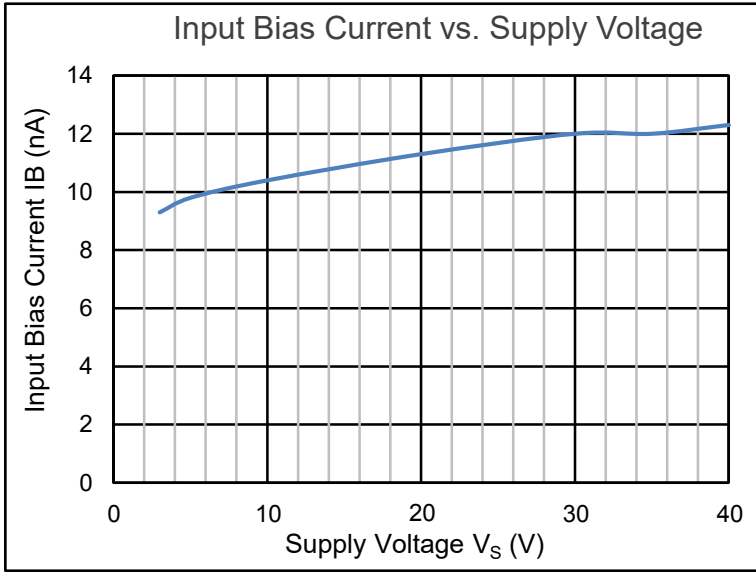

Large-Signal Step Response
($V_S = 15V$)

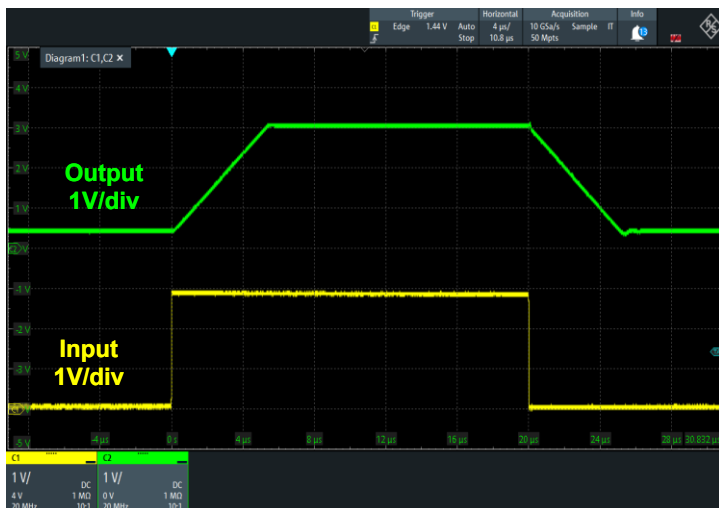

Small-Signal Step Response
($V_S = 15V$)

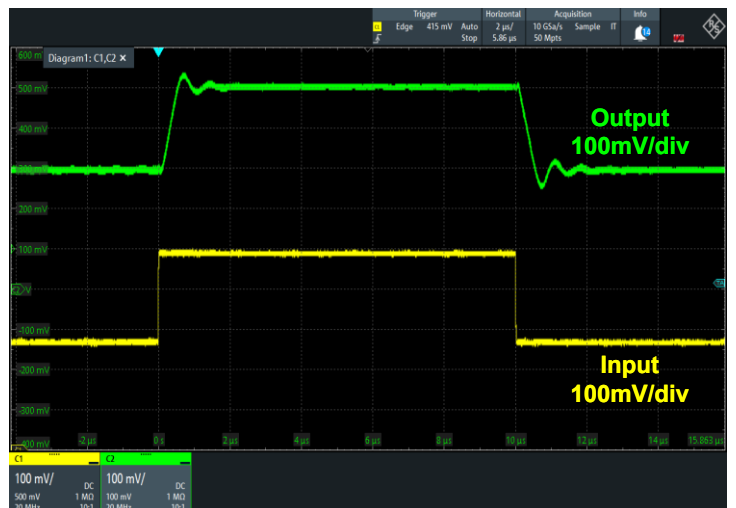

7 Detail Description

7.1 Description

The LM321E consists of one high gain, low-power consumption operational amplifiers, which can be powered by a single power supply. The V_S should be at least 1.5V higher than the input common mode voltage. The low power supply current is independent of the power supply voltage. The LM321E can be directly powered from a standard 5V power supply used in digital systems without the need for an additional $\pm 5V$ power supply.

7.2 Representative Schematic Diagram

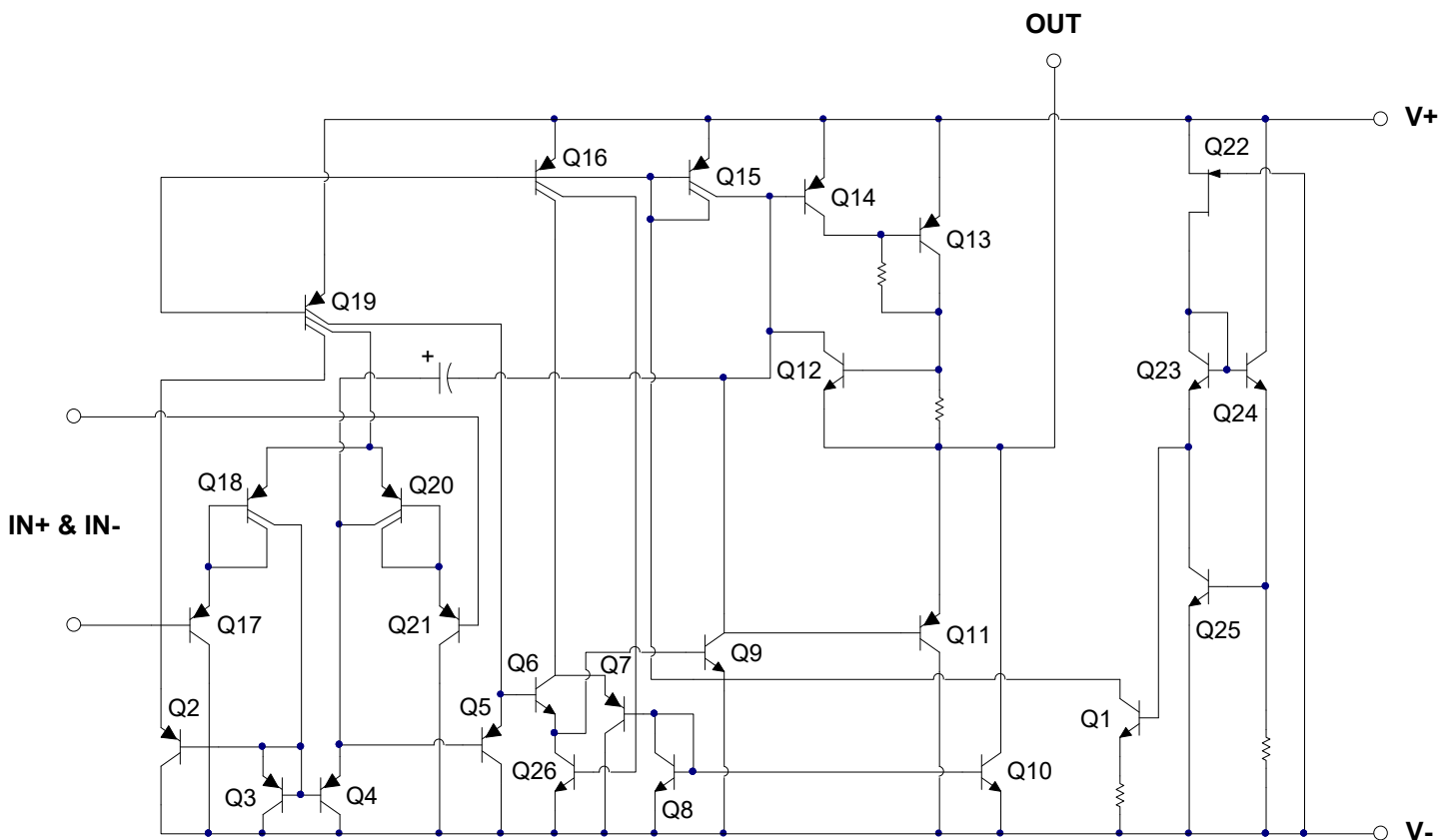

8 Application and Implementation

8.1 Typical Application Circuits

The LM321E operational amplifier can operate with a single or dual power supply voltage, has true-differential inputs, and remains in the linear mode with an input common-mode voltage of 0VDC. This amplifier operates over a wide range of power supply voltages, with little change in performance characteristics. At 25°C amplifier operation is possible down to a minimum supply voltage of 3V. Large differential input voltages can be easily accommodated and, as input differential voltage protection diodes are not needed, no large input currents result from large differential input voltages. The differential input voltage may be larger than V+ without damaging the device. Protection should be provided to prevent the input voltages from going negative more than -0.3VDC (at 25°C). An input clamp diode with a resistor to the IC input terminal can be used.

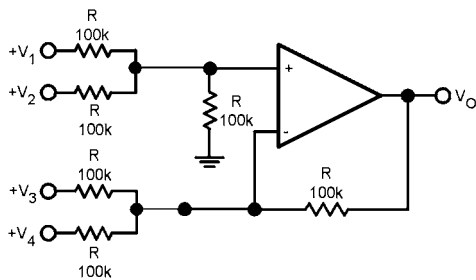

Where: $V_O = V_1 + V_2 - V_3 - V_4$, $(V_1 + V_2) \geq (V_3 + V_4)$ to keep $V_O > 0 V_{DC}$

Figure 8-1. DC Summing Amplifier
($V_{IN}'s \geq 0 V_{DC}$ and $V_O \geq V_{DC}$)

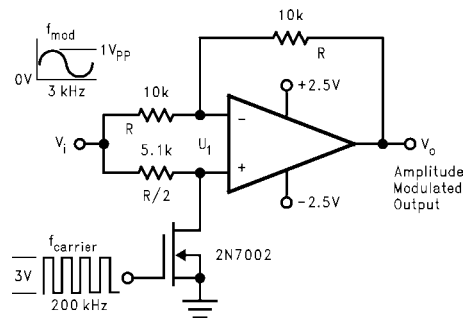
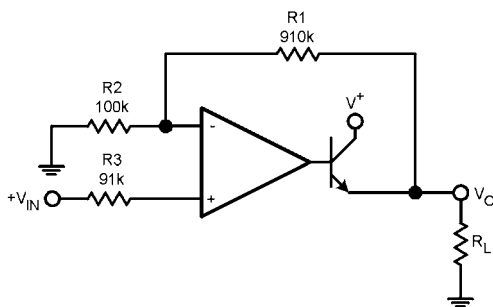

Figure 8-2. Amplitude Modulator Circuit



$V_O = 0 V_{DC}$ for $V_{IN} = 0 V_{DC}$, $A_V = 10$

Figure 8-3. Power Amplifier

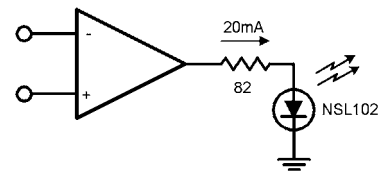
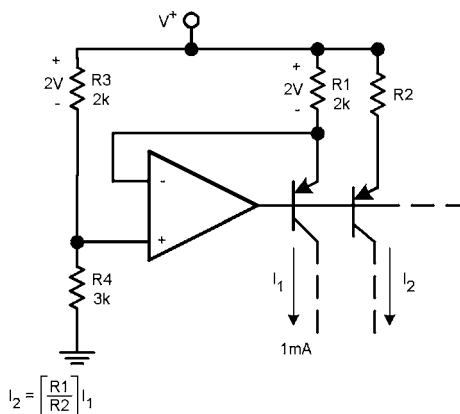

Figure 8-4. LED Driver



$$I_2 = \left[\frac{R1}{R2} \right] I_1$$

Figure 8-5. Fixed Current Sources

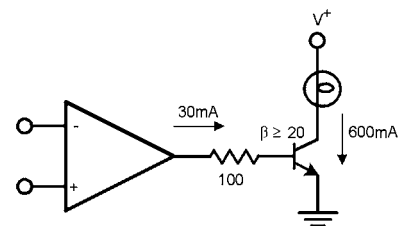

Figure 8-6. Lamp Driver

8 Application and Implementation

8.2 Layout Guidelines

The LM321E is widely used in various operational amplifier circuits. The following points should be taken in circuit design and PCB layout to help devices obtain the best operating performance:

1. Signal transmission traces should be as far away as possible from power supply traces to reduce parasitic coupling. It is recommended that signal traces be kept at least 5mm away from power supply lines. If the layout of the circuit does not allow this, it is better to lay out these traces vertically to avoid being parallel to each other as much as possible;
2. The length of the power supply traces should be as short as possible and bypass the power supply appropriately so as to reduce the power disturbance caused by current changes, such as when driving an AC signal to a heavy load;
3. It is recommended to use a bypass capacitor between each power supply pin (single power supply is V+, dual power supply is V+ and V-) and ground to reduce coupling noise transmitted through the power supply pins and operational amplifiers to the entire circuit. It is recommended to use ceramic bypass capacitors with low ESR and 0.1 μ F, and ensure that they are placed as close as possible to the corresponding pins of the device;
4. External components should be placed as close as possible to the device, and keeping R_I and R_F close to the input can minimize parasitic capacitance.
5. Analog grounding and digital grounding should be physically separated. Grounding the analog and digital parts of the circuit separately is a very simple but effective method for suppressing noise. When designing and laying out a multi-layer PCB circuit, one or more layers can be dedicated to a grounding layer, which can reduce EMI noise and help distribute appropriate heat on the circuit board;
6. Make sure the surface of the printed circuit board is clean and moisture-free. Use a surface coating to prevent moisture accumulation and help reduce parasitic resistance on the printed circuit board. Consider setting a low impedance guard ring (as shown in Figure 8-7) for the driver around the critical trace. The guard ring can significantly reduce the leakage current of nearby traces at different potentials.

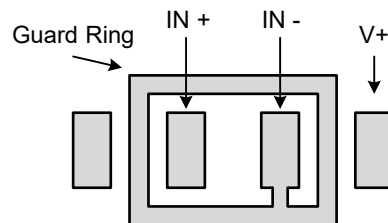

Figure 8-7. Guard Ring

NOTE

The application information in this section is not part of the data sheet component specification, and JSCJ makes no commitment or statement to guarantee its accuracy or completeness. Customers are responsible for determining the rationality of corresponding components in their circuit design and making tests and verifications to ensure the normal realization of their circuit design.

9 Notes and Revision History

9.1 Associated Product Family and Others

To view other products of the same type or IC products of other types, click the official website of JSCJ -- <https://www.jscj-elec.com> for more details.

9.2 Notes

Electrostatic Discharge Caution



This IC may be damaged by ESD. Relevant personnel shall comply with correct installation and use specifications to avoid ESD damage to the IC. If appropriate measures are not taken to prevent ESD damage, the hazards caused by ESD include but are not limited to degradation of integrated circuit performance or complete damage of integrated circuit. For some precision integrated circuits, a very small parameter change may cause the whole device to be inconsistent with its published specifications.

9.3 Revision History

September 2025: released LM321E rev - 1.0.

10 Orderable, Mechanical, and Packaging Information

The following pages include mechanical packaging and orderable information. This information is the most current data available for the designated devices. This data is subject to change without notice and revision of this document. For browser based versions of this data sheet, refer to the left hand navigation.

Orderable Information

MODEL	DEVICE	PACKAGE	OP TEMP	ECO PLAN	MSL	PACKING OPTION	SORT
LM321E	LM321E-M5N	SOT-23-5L	-40 ~ 85°C	RoHS & Green	Level 3 168 HR	Tape and Reel 3000 Units / Reel	Active
Others	-	-	-	-	-	-	Customized

Note:

ECO PLAN: For the RoHS and Green certification standards of this product, please refer to the official report provided by JSCJ.

MSL: Moisture Sensitivity Level. Determined according to JEDEC industry standard classification.

SORT: Specifically defined as follows:

Active: Recommended for new products;

Customized: Products manufactured to meet the specific needs of customers;

Preview: The device has been released and has not been fully mass produced. The sample may or may not be available;

NoRD: It is not recommended to use the device for new design. The device is only produced for the needs of existing customers; Obsolete: The device has been discontinued.

Mechanical Information

SOT-23-5L Mechanical Information

SOT-23-5L Outline Dimensions

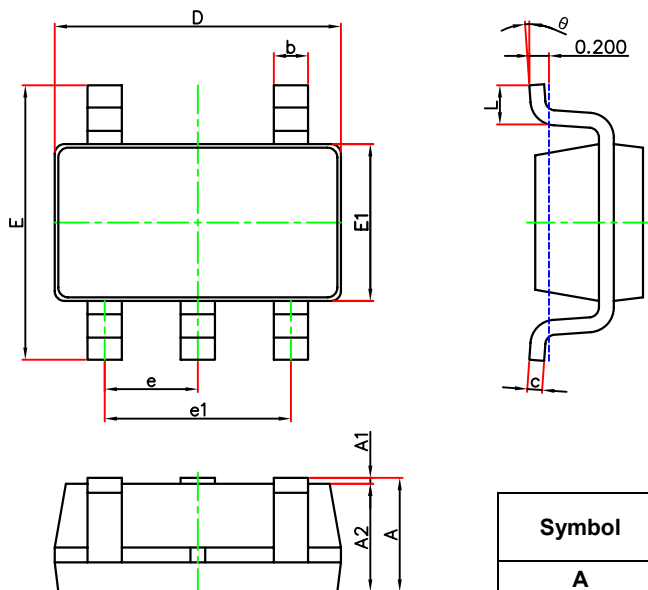

Symbol	Dimensions In Millimeters		Dimensions In Inches	
	Min.	Max.	Min.	Max.
A	1.050	1.250	0.041	0.049
A1	0.000	0.100	0.000	0.004
A2	1.000	1.200	0.039	0.047
b	0.300	0.500	0.012	0.020
c	0.100	0.200	0.004	0.008
D	2.820	3.020	0.111	0.119
E	2.600	3.000	0.102	0.118
E1	1.500	1.700	0.059	0.067
e	0.950(BSC)		0.037(BSC)	
e1	1.800	2.000	0.071	0.079
L	0.300	0.600	0.012	0.024
θ	0°	8°	0°	8°

SOT-23-5L Suggested Pad Layout

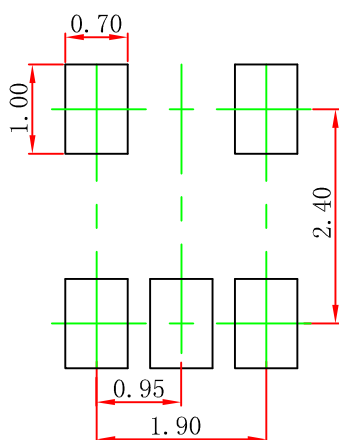

Note:

1. Controlling dimension: in millimeters.
2. General tolerance: $\pm 0.05\text{mm}$.
3. The pad layout is for reference purpose only.

Packaging Information

SOT-23-5L Tape and Reel Information

SOT-23-5L Tape and Reel Information

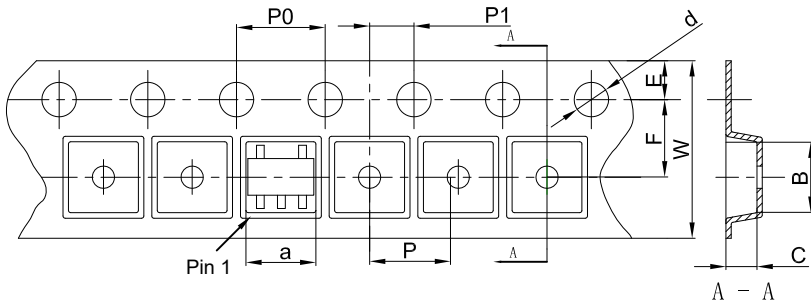

Packaging Description:

SOT-23-5L parts are shipped in tape. The carrier tape is made from a dissipative (carbon filled) polycarbonate resin. The cover tape is a multilayer film (Heat Activated Adhesive in nature) primarily composed of polyester film, adhesive layer, sealant, and anti-static sprayed agent. These reeled parts in standard option are shipped with 3,000 units per 7" or 18.0cm diameter reel. The reels are clear in color and is made of polystyrene plastic (anti-static coated).

Dimensions are in millimeter										
Pkg type	a	B	C	d	E	F	P0	P	P1	W
SOT-23-5L	3.17	3.23	1.37	Ø1.55	1.75	3.50	4.00	4.00	2.00	8.00

SOT-23-5L Tape Leader and Trailer

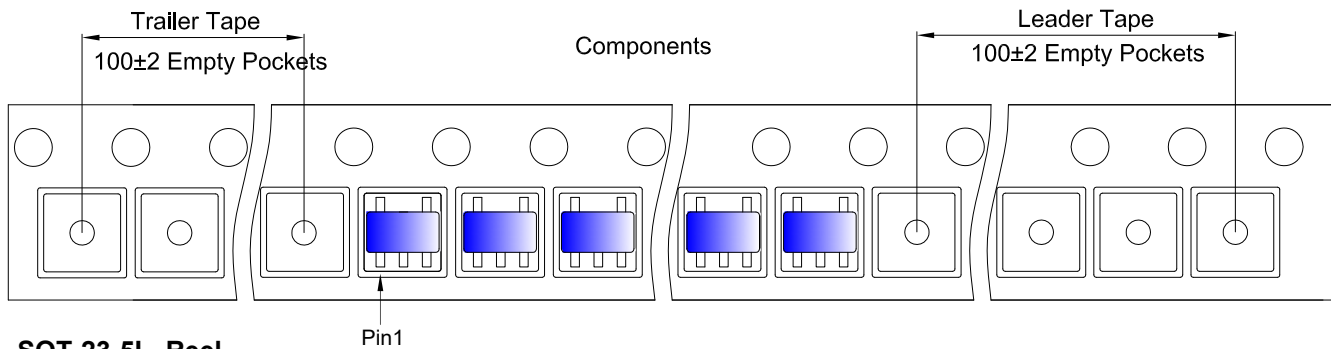

SOT-23-5L Reel

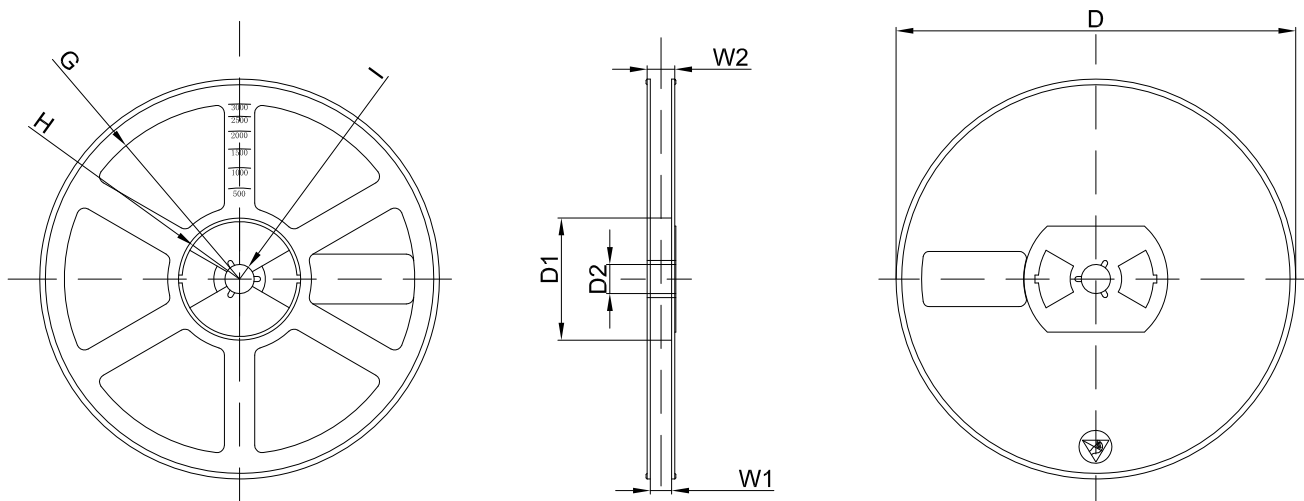

Dimensions are in millimeter								
Reel Option	D	D1	D2	G	H	I	W1	W2
7" Dia	Ø180.00	60.00	13.00	R78.00	R25.60	R6.50	9.50	13.10

REEL	Reel Size	Box	Box Size(mm)	Carton	Carton Size(mm)	G.W.(kg)
3000 pcs	7 inch	30,000 pcs	203×203×195	120,000 pcs	438×438×220	

DISCLAIMER

IMPORTANT NOTICE, PLEASE READ CAREFULLY

The information in this data sheet is intended to describe the operation and characteristics of our products. JSCJ has the right to make any modification, enhancement, improvement, correction or other changes to any content in this data sheet, including but not limited to specification parameters, circuit design and application information, without prior notice.

Any person who purchases or uses JSCJ products for design shall: 1. Select products suitable for circuit application and design; 2. Design, verify and test the rationality of circuit design; 3. Procedures to ensure that the design complies with relevant laws and regulations and the requirements of such laws and regulations. JSCJ makes no warranty or representation as to the accuracy or completeness of the information contained in this data sheet and assumes no responsibility for the application or use of any of the products described in this data sheet.

Without the written consent of JSCJ, this product shall not be used in occasions requiring high quality or high reliability, including but not limited to the following occasions: medical equipment, military facilities and aerospace. JSCJ shall not be responsible for casualties or property losses caused by abnormal use or application of this product.

Official Website: www.jscj-elec.com

Copyright © JIANGSU CHANGJING ELECTRONICS TECHNOLOGY CO., LTD.