



LM393E and LM2903E Comparators

1 Introduction

The LM393E and LM2903E are dual channel voltage comparators with very low input offset voltage specification. They are designed to operate from a single power supply over a wide range of voltages, however operation from split power supplies is also possible. They offer low power supply current independent of the magnitude of the power supply voltage.

These comparators family are designed to directly interface with TTL and CMOS. When operating from both plus and minus power supplies, the comparators could directly interface with MOS logic where their low power drain is a distinct advantage over standard comparators. The LM393E and LM2903E are offered in SOP8 package.

2 Available Packages

PART NUMBER	PACKAGE
LM393E-PAN	SOP8
LM2903E-PAN	SOP8

3 Features

- Wide Supply: 3.0V to 36V
- Faster Response Time: 1.3 μ s (typical)
- Low Input Bias Current: 25nA (typical)
- Large Voltage Gain: 100dB (typical)
- Low Offset Voltage: \pm 2mV (typical)
- Open Collector Output
- Input Common-Mode Voltage Range Includes Ground
- Differential Input Voltage Range Equal to Power Supply
- Extended Temperature Range:
LM393E:-40°C to +85°C
LM2903E:-40°C to +125°C

4 Applications

- Industrial Application
- Solar Inverter
- White Goods
- Battery Management System
- Medical Equipment

5 Pin Configuration and Marking Information

5.1 Pin Configuration and Function

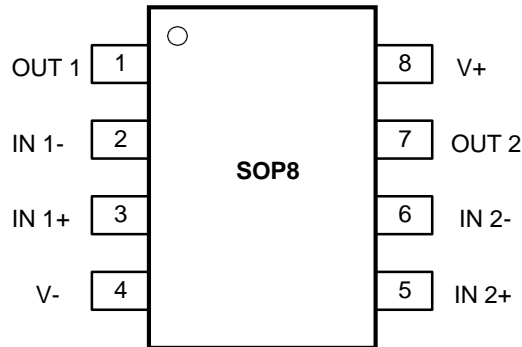
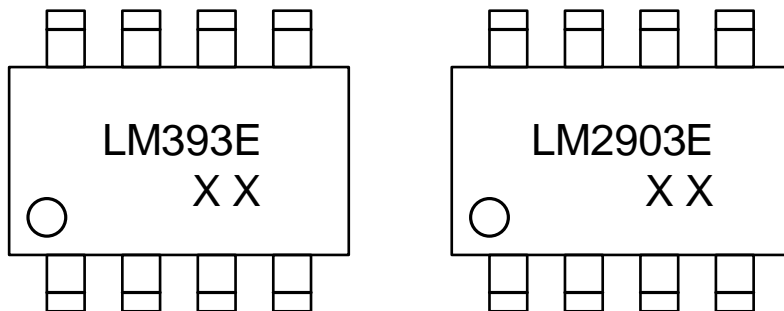

Figure 5-1. LM393E and LM2903E Pin Map

PIN	LM393E/ LM2903E	I / O	DESCRIPTION
NAME	SOP8		
OUT 1	1	O	Output of the operational amplifier 1.
IN 1-	2	I	Negative input of the operational amplifier 1.
IN 1+	3	I	Positive input of the operational amplifier 1.
V-	4	-	Negative (lowest) supply or ground for single supply.
IN 2+	5	I	Positive input of the operational amplifier 2.
IN 2-	6	I	Negative input of the operational amplifier 2.
OUT 2	7	O	Output of the operational amplifier 2.
V+	8	-	Positive (highest) supply.

5.2 Marking Information



"LM393 and LM2903": Device number.

"XX ": Code, indicates weekly record information.

6 Specifications

6.1 Absolute Maximum Ratings

(over operating ambient temperature range, unless otherwise specified)⁽¹⁾

CHARACTERISTIC	SYMBOL	VALUE	UNIT
Supply voltage[(V+)-(V-)]	V_S	40	V
Signal input Voltage ⁽²⁾ range	-	-0.3~40V	V
Differential input voltage	-	±36	mA
Output short-circuit	T_{sc}	Continuous ⁽³⁾	mA
Maximum junction temperature	$T_{J\ MAX}$	150	°C
Storage temperature	T_{stg}	-65 ~ 150	°C
Soldering temperature & time	T_{solder}	260°C, 10s	-

(1) Stresses beyond those listed under *Absolute Maximum Ratings* may cause permanent damage to the device. These are stress ratings only, which do not imply functional operation of the device at these or any other conditions beyond those indicated under *Recommended Operating Conditions*. Exposure to absolute-maximum rated conditions for extended periods may affect device reliability.

(2) Input pins are diode-clamped to the power-supply rails. Current limit input signals that can swing more than 0.5V beyond the supply rails to 10mA or less.

(3) Short circuits from outputs to V_S can cause excessive heating and eventual destruction. A heat sink may be required to keep the junction temperature below the absolute maximum. This depends on the power supply voltage and how many amplifiers are shorted. Thermal resistance varies with the amount of PC board metal connected to the package. The specified values are for short traces connected to the leads.

6.2 Recommend Operating Conditions

(over operating ambient temperature range, unless otherwise specified)

PARAMETER		SYMBOL	MIN.	NOM.	MAX.	UNIT
Power supply range		V_S	3.0	-	36	V
Operating ambient temperature	LM393E	T_A	-40	-	85	°C
	LM2903E		-40	-	125	°C

6 Specifications

6.3 ESD Ratings

ESD RATINGS		VALUE	UNIT
Electrostatic discharge	Human-body model (HBM), per ANSI/ESDA/JEDEC JS-001 ⁽⁴⁾	1500	V

(4) JEDEC document JEP155 states that 500V HBM allows safe manufacturing with a standard ESD control process.

6.4 Thermal Information

THERMAL METRIC ⁽⁵⁾	SYMBOL	SOP8	UNIT
Junction-to-ambient thermal resistance	$R_{\theta JA}$	125.0	°C/W
Reference maximum power dissipation (continuous)	$P_{D Ref}$	1.00	W

(5) $T_A = 25^\circ\text{C}$, measured on evaluation board with 1oz. copper traces of minimum pad size, all device outputs were active.

6 Specifications

6.5 Electrical Characteristics

LM393E ($V_S = 5.0V$ to $36V$, $T_A = +25^\circ C$, unless otherwise noted.)

CHARACTERISTIC	SYMBOL	TEST CONDITIONS	MIN.	TYP.	MAX.	UNIT
OFFSET VOLTAGE						
Input offset voltage	V_{OS}	$V_S = 5.0V$ to $30V$, $V_{OUT} = 1.4V$	-	1	5	mV
		$V_S = 5.0V$ to $30V$, $V_{OUT} = 1.4V$ $T_A = -40$ to $+85^\circ C$	-	-	9	
INPUT BIAS CURRENT						
Input bias current	I_B	$V_{CM} = 0$	-	-25	-250	nA
		$V_{CM} = 0$, $T_A = -40$ to $+85^\circ C$	-	-	-400	
Input offset current	I_{OS}	$V_{CM} = 0$	-	2	50	nA
		$V_{CM} = 0$, $T_A = -40$ to $+85^\circ C$	-	-	200	
INPUT VOLTAGE						
Common-mode voltage range	V_{CM}	$V_S = 5.0V$ to $36V$	$-V_S$	-	$+V_S - 1.5$	V
		$V_S = 5.0V$ to $36V$, $T_A = -40$ to $+85^\circ C$	$-V_S$	-	$+V_S - 2.0$	
VOLTAGE GAIN						
Large-signal differential-voltage amplification	A_{VD}	$V_S = 15.0V$, $V_{OUT} = 1V \sim 11V$ $R_L \geq 15k$	50	200	-	V/mV
PROPAGATION DELAY TIME						
Propagation delay time	T_{PD}	$R_L = 5.1k$, $V_{RL} = 5V$, $C_L = 15pF$ TTL-Level Input Step	-	0.3	-	μs
		$R_L = 5.1k$, $V_{RL} = 5V$, $C_L = 15pF$ 100mV Input Step With 5mV Overdrive	-	1.3	-	
OUTPUT						
Low level output Voltage	V_{OL}	$I_{OL} = 4mA$, $V_{ID} = -1V$	-	140	400	mV
		$I_{OL} = 4mA$, $V_{ID} = -1V$, $T_A = -40$ to $+85^\circ C$	-	-	700	
Low-level output current	I_{OL}	$V_{OL} = 1.5V$, $V_{ID} = -1V$	6	14	-	mA
High-level output current	I_{OH}	$V_{OL} = 5V$, $V_{ID} = 1V$	-	0.1	50	nA
		$V_{OL} = 30V$, $V_{ID} = 1V$, $T_A = -40$ to $+85^\circ C$	-	-	1	μA
POWER SUPPLY						
Quiescent current	I_Q	$V_S = 5V$	-	480	1000	μA
		$V_S = 36V$	-	600	1500	

6 Specifications

6.5 Electrical Characteristics

LM2903E ($V_S = 5.0V$ to $36V$, $T_A = +25^\circ C$, unless otherwise noted.)

CHARACTERISTIC	SYMBOL	TEST CONDITIONS	MIN.	TYP.	MAX.	UNIT
OFFSET VOLTAGE						
Input offset voltage	V_{OS}	$V_S = 5.0V$ to $30V$, $V_{OUT} = 1.4V$	-	1	5	mV
		$V_S = 5.0V$ to $30V$, $V_{OUT} = 1.4V$ $T_A = -40$ to $+125^\circ C$	-	-	9	
INPUT BIAS CURRENT						
Input bias current	I_B	$V_{CM} = 0$	-	-25	-250	nA
		$V_{CM} = 0$, $T_A = -40$ to $+125^\circ C$	-	-	-400	
Input offset current	I_{OS}	$V_{CM} = 0$	-	2	50	nA
		$V_{CM} = 0$, $T_A = -40$ to $+125^\circ C$	-	-	200	
INPUT VOLTAGE						
Common-mode voltage range	V_{CM}	$V_S = 5.0V$ to $36V$	$-V_S$	-	$+V_S - 1.5$	V
		$V_S = 5.0V$ to $36V$, $T_A = -40$ to $+125^\circ C$	$-V_S$	-	$+V_S - 2.0$	
VOLTAGE GAIN						
Large-signal differential-voltage amplification	A_{VD}	$V_S = 15.0V$, $V_{OUT} = 1V \sim 11V$ $R_L \geq 15K$	50	200	-	V/mV
PROPAGATION DELAY TIME						
Propagation delay time	T_{PD}	$R_L = 5.1k$, $V_{RL} = 5V$, $C_L = 15pF$ TTL-Level Input Step	-	0.3	-	μs
		$R_L = 5.1k$, $V_{RL} = 5V$, $C_L = 15pF$ 100mV Input Step With 5mV Overdrive	-	1.3	-	
OUTPUT						
Low level output Voltage	V_{OL}	$I_{OL} = 4mA$, $V_{ID} = -1V$	-	140	400	mV
		$I_{OL} = 4mA$, $V_{ID} = -1V$, $T_A = -40$ to $+125^\circ C$	-	-	700	
Low-level output current	I_{OL}	$V_{OL} = 1.5V$, $V_{ID} = -1V$	6	14	-	mA
High-level output current	I_{OH}	$V_{OL} = 5V$, $V_{ID} = 1V$	-	0.1	50	nA
		$V_{OL} = 30V$, $V_{ID} = 1V$, $T_A = -40$ to $+125^\circ C$	-	-	1	μA
POWER SUPPLY						
Quiescent current of LM393E/LM2903E	I_Q	$V_S = 5V$	-	480	1000	μA
		$V_S = 36V$	-	600	1500	

6 Specifications

6.6 Typical Characteristics

$V_S = 5V$, $R_L = 5.1k$, $T_A = 25^\circ C$ and $V_{OUT} = 0V$, unless otherwise noted.

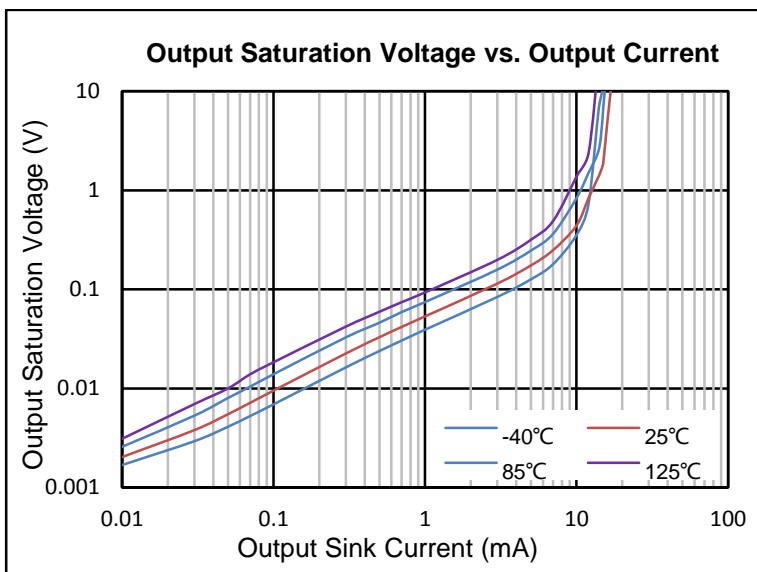
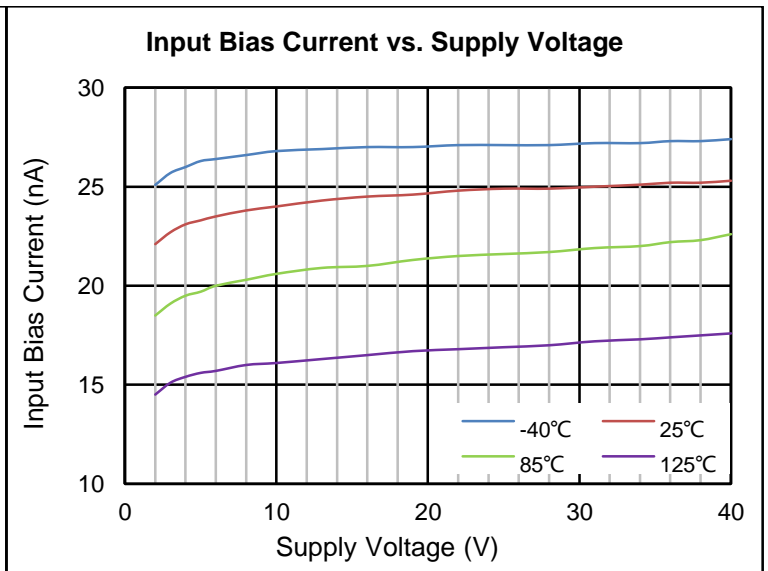
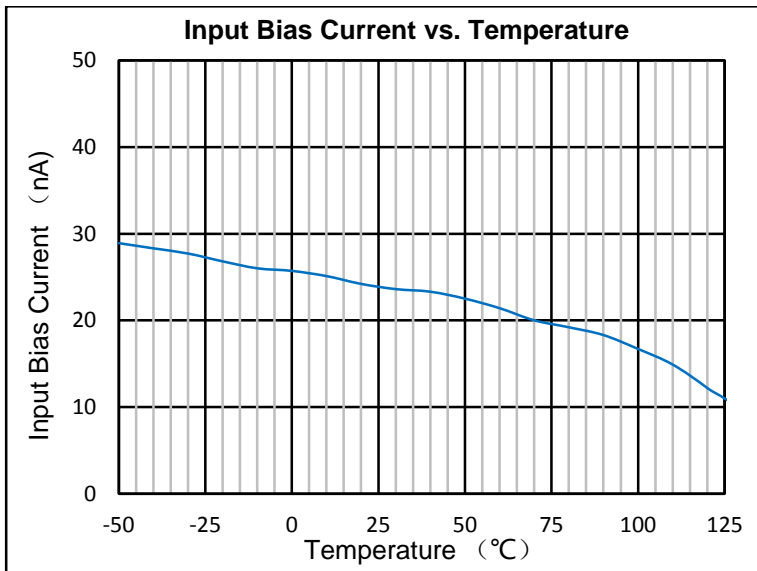
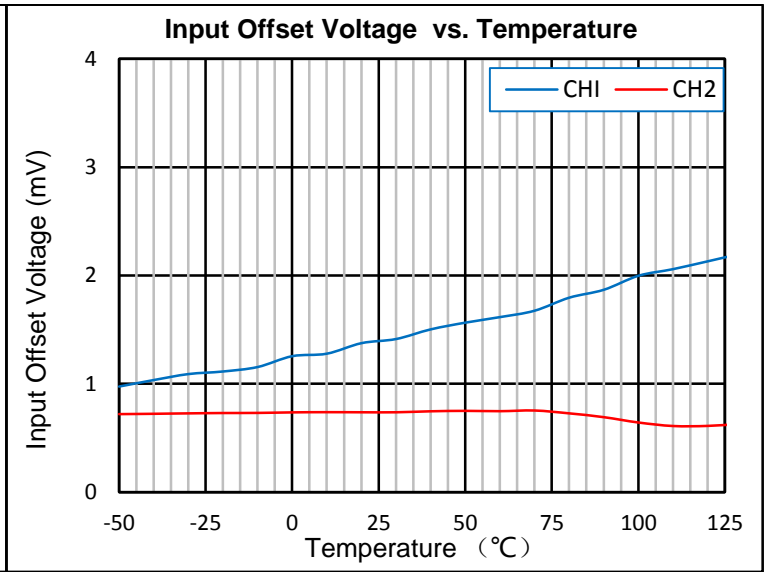
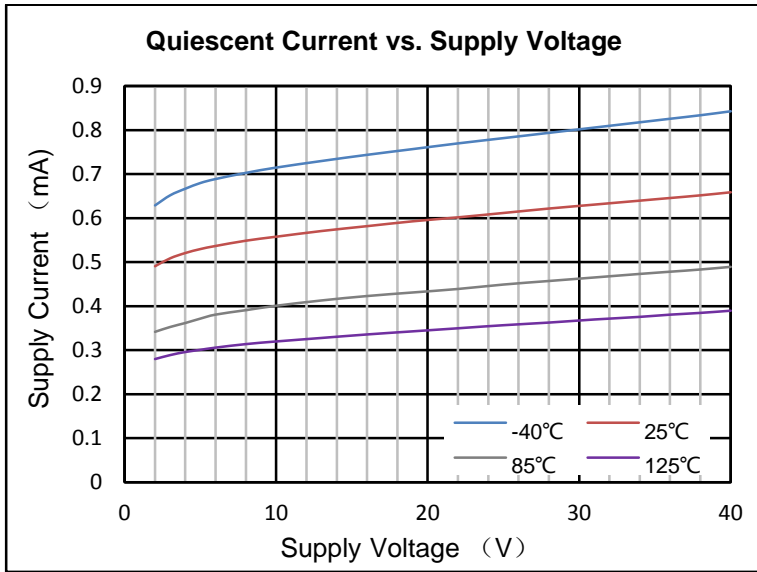

6 Specifications

6.6 Typical Characteristics (continued)

$T_A = 25^\circ\text{C}$, $V_S = 5\text{V}$, $R_{\text{PULLUP}} = 5.1\text{k}$, $C_L = 15\text{pF}$, $V_{\text{CM}} = 0\text{V}$, $V_{\text{UNDERDRIVE}} = 100\text{mV}$, $V_{\text{OVERDRIVE}} = 100\text{mV}$ unless otherwise noted.

Response Time for Various Over drives Negative Transition

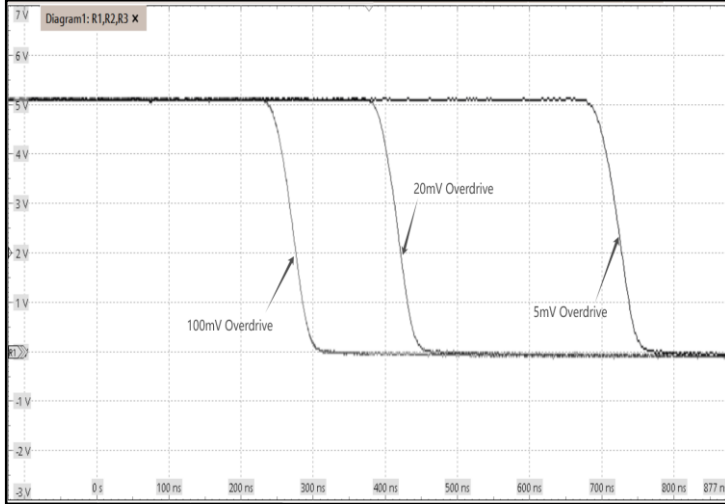

Response Time for Various Over drives Positive Transition

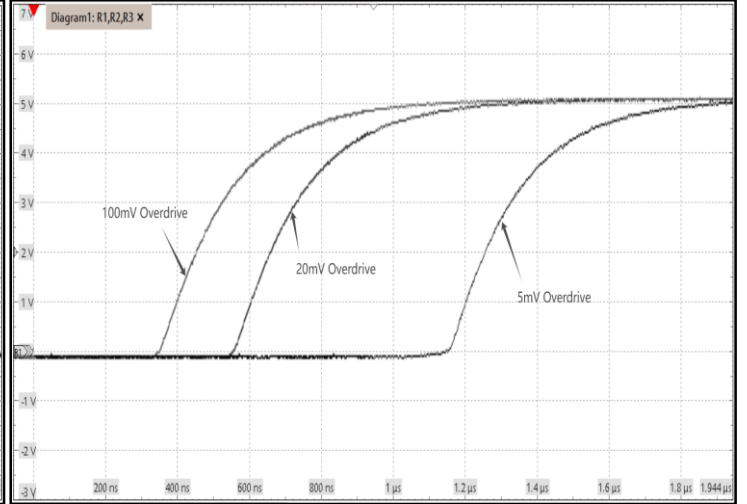

7 Detail Description

7.1 Description

The LM393E and LM2903E are dual channel voltage comparators with very low input offset voltage specification. They are designed to operate from a single power supply over a wide range of voltages, however operation from split power supplies is also possible. They offer low power supply current independent of the magnitude of the power supply voltage.

7.2 Feature Description

The comparator consists of a PNP Darlington pair input, allowing the device to operate with very high gain and fast response with minimal input bias current. The input Darlington pair creates a limit on the input common mode voltage capability, allowing the comparator to accurately function from ground to $V_{CC} - 2V$ over temperature. A clamp is added around Q3 to mimic the both inputs above input voltage range behavior of the original classic silicon.

The output consists of an open drain NPN (pull-down or low side) transistor. The output NPN sinks current when the negative input voltage is higher than the positive input voltage and the offset voltage. The V_{OL} is resistive and scales with the output current. Please see the "Output Low Voltage vs. Output Sinking Current" graphs for V_{OL} values with respect to the output current.

8 Application and Implementation

8.1 Application Information

The LM393E and LM2903E are typically used to compare a single signal to a reference or two signals against each other. Many users take advantage of the open drain output to drive the comparison logic output to a logic voltage level to an MCU or logic device. The wide supply range and high voltage capability makes this comparator optimal for level shifting to a higher or lower voltage.

8.2 Typical Application Circuits

The LM393E and LM2903E family are designed to directly interface with TTL and CMOS. When operating from both plus and minus power supplies, the comparators could directly interface with MOS logic where their low power drain is a distinct advantage over standard comparators.

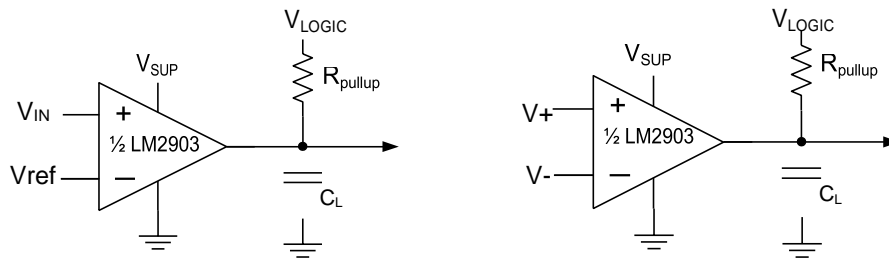

Figure 8-1. Single-Ended and Differential Comparator Configurations

IR Receiver

The LM393E/LM2903E is an ideal candidate to be used as an infrared receiver shown in Figure 8-2. The infrared photo diode creates a current relative to the amount of infrared light present. The current creates a voltage across R_D . When this voltage level crosses the voltage applied by the voltage divider to the inverting input, the output transitions. Optional R_o provides additional hysteresis for noise immunity.

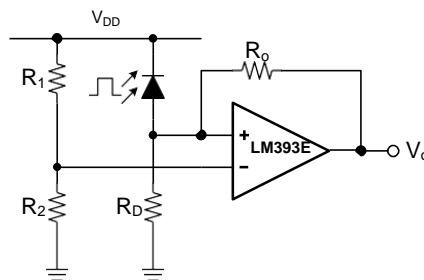

Figure 8-2. IR Receiver

8 Application and Implementation

8.3 Power Supply Recommendations

The LM393E/LM2903E family's power supply pin should have a local bypass capacitor (i.e., 0.01 μ F to 0.1 μ F) within 2mm for good high frequency performance. It can also use a bulk capacitor (i.e., 1 μ F or larger) within 100mm to provide large, slow currents. This bulk capacitor can be shared with other analog parts.

Good ground layout improves performance by decreasing the amount of stray capacitance and noise at the comparator's inputs and outputs. To decrease stray capacitance, minimize PCB lengths and resistor leads, and place external components as close to the comparator's pins as possible.

8.4 Layout Guidelines

To achieve the maximum performance of the extremely high input impedance and low offset voltage of the LM393E/LM2903E devices, care is needed in laying out the circuit board. The PCB surface must remain clean and free of moisture to avoid leakage currents between adjacent traces. Surface coating of the circuit board reduces surface moisture and provides a humidity barrier, reducing parasitic resistance on the board. The use of guard rings around the amplifier inputs further reduces leakage currents. Figure 8-3 shows proper guard ring configuration and the top view of a surface-mount layout. The guard ring does not need to be a specific width, but it should form a continuous loop around both inputs. By setting the guard ring voltage equal to the voltage at the non-inverting input, parasitic capacitance is minimized as well. For further reduction of leakage currents, components can be mounted to the PCB using Teflon standoff insulators.

Other potential sources of offset error are thermoelectric voltages on the circuit board. This voltage, also called Seebeck voltage, occurs at the junction of two dissimilar metals and is proportional to the temperature of the junction. The most common metallic junctions on a circuit board are solder-to-board trace and solder-to-component lead. If the temperature of the PCB at one end of the component is different from the temperature at the other end, the resulting Seebeck voltages are not equal, resulting in a thermal voltage error.

This thermocouple error can be reduced by using dummy components to match the thermoelectric error source. Placing the dummy component as close as possible to its partner ensures both Seebeck voltages are equal, thus canceling the thermocouple error. Maintaining a constant ambient temperature on the circuit board further reduces this error. The use of a ground plane helps distribute heat throughout the board and reduces EMI noise pickup.

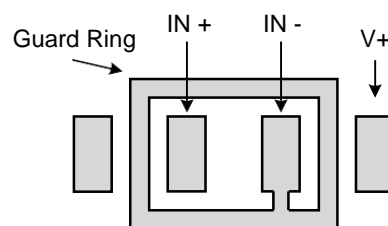

Figure 8-3. Guard Ring

9 Notes and Revision History

9.1 Associated Product Family and Others

To view other products of the same type or IC products of other types, click the official website of JSCJ -- <https://www.jscj-elec.com> for more details.

9.2 Notes

Electrostatic Discharge Caution



This IC may be damaged by ESD. Relevant personnel shall comply with correct installation and use specifications to avoid ESD damage to the IC. If appropriate measures are not taken to prevent ESD damage, the hazards caused by ESD include but are not limited to degradation of integrated circuit performance or complete damage of integrated circuit. For some precision integrated circuits, a very small parameter change may cause the whole device to be inconsistent with its published specifications.

9.3 Revision History

June 2025: released LM393E and LM2903E rev - 1.0.

DISCLAIMER

IMPORTANT NOTICE, PLEASE READ CAREFULLY

The information in this data sheet is intended to describe the operation and characteristics of our products. JSCJ has the right to make any modification, enhancement, improvement, correction or other changes to any content in this data sheet, including but not limited to specification parameters, circuit design and application information, without prior notice.

Any person who purchases or uses JSCJ products for design shall: 1. Select products suitable for circuit application and design; 2. Design, verify and test the rationality of circuit design; 3. Procedures to ensure that the design complies with relevant laws and regulations and the requirements of such laws and regulations. JSCJ makes no warranty or representation as to the accuracy or completeness of the information contained in this data sheet and assumes no responsibility for the application or use of any of the products described in this data sheet.

Without the written consent of JSCJ, this product shall not be used in occasions requiring high quality or high reliability, including but not limited to the following occasions: medical equipment, military facilities and aerospace. JSCJ shall not be responsible for casualties or property losses caused by abnormal use or application of this product.

Official Website: www.jscj-elec.com

Copyright © JIANGSU CHANGJING ELECTRONICS TECHNOLOGY CO., LTD.

Orderable Information

MODEL	DEVICE	PACKAGE	OP TEMP	ECO PLAN	MSL	PACKING OPTION	SORT
LM393E	LM393E-PAN	SOP8	-40 ~ 85°C	RoHS & Green	Level 3 168 HR	Tape and Reel 4000 Units / Reel	Active
LM2903E	LM2903E-PAN	SOP8	-40 ~ 125°C	RoHS & Green	Level 3 168 HR	Tape and Reel 4000 Units / Reel	Active
Others	-	-	-	-	-	-	Customized

Note:

ECO PLAN: For the RoHS and Green certification standards of this product, please refer to the official report provided by JSCJ.

MSL: Moisture Sensitivity Level. Determined according to JEDEC industry standard classification.

SORT: Specifically defined as follows:

Active: Recommended for new products;

Customized: Products manufactured to meet the specific needs of customers;

Preview: The device has been released and has not been fully mass produced. The sample may or may not be available;

NoRD: It is not recommended to use the device for new design. The device is only produced for the needs of existing customers;

Obsolete: The device has been discontinued.

Mechanical Information

SOP8 Mechanical Information

Outline Dimensions

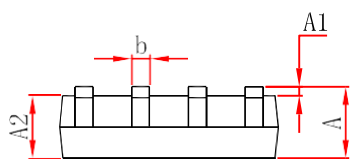
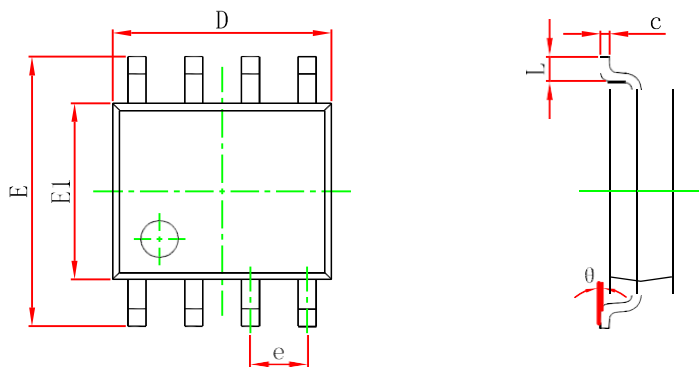

Symbol	Dimensions In Millimeters		Dimensions In Inches	
	Min	Max	Min	Max
A	1.370	1.670	0.054	0.066
A1	0.070	0.250	0.003	0.010
A2	1.350	1.550	0.053	0.061
b	0.300	0.510	0.013	0.020
c	0.170	0.250	0.007	0.010
D	4.700	5.100	0.185	0.201
e	1.270 (BSC)		0.050 (BSC)	
E	5.800	6.200	0.228	0.244
E1	3.800	4.000	0.150	0.157
L	0.400	1.270	0.016	0.050
theta	0°	8°	0°	8°

SOP8 Suggest Pad Layout

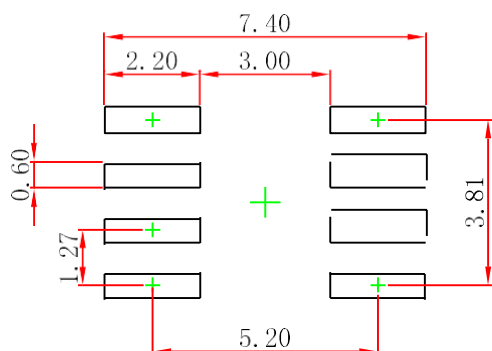

NOTE:

1. Controlling dimension: in millimeters.
2. General tolerance: $\pm 0.05\text{mm}$.
3. The pad layout is for reference purposes only.

Packaging Information

SOP8 Tape and Reel Information

Embossed Carrier Tape

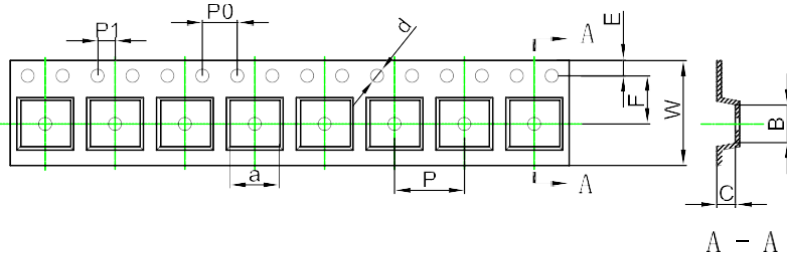

Packaging Description:

SOP8 parts are shipped in tape. The carrier tape is made from a dissipative (carbon filled) polycarbonate resin. The cover tape is a multilayer film (Heat Activated Adhesive in nature) primarily composed of polyester film, adhesive layer, sealant, and anti-static sprayed agent. These reeled parts in standard option are shipped with 2,500 units per 13" or 33cm diameter reel. The reels are clear in color and is made of polystyrene plastic (anti-static coated).

ALL DIM IN mm

Dimensions are in millimeter										
Pkg type	a	B	C	d	E	F	P0	P	P1	W
SOP8	6.40	5.40	2.10	Ø1.50	1.75	5.50	4.00	8.00	2.00	12.00

Tape Leader and Trailer

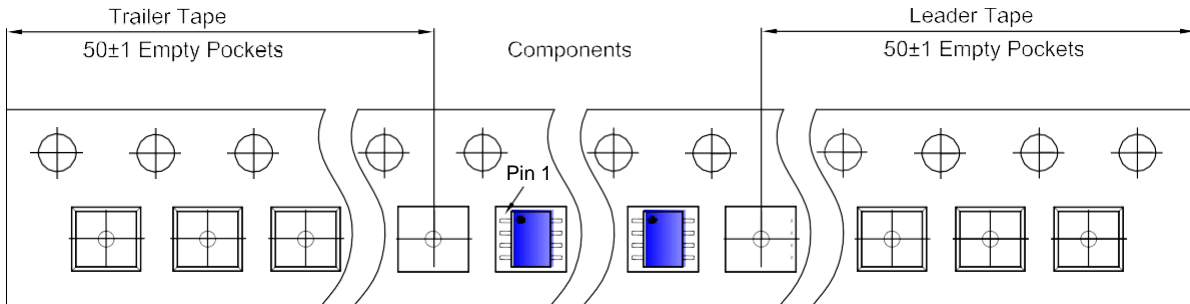

Reel

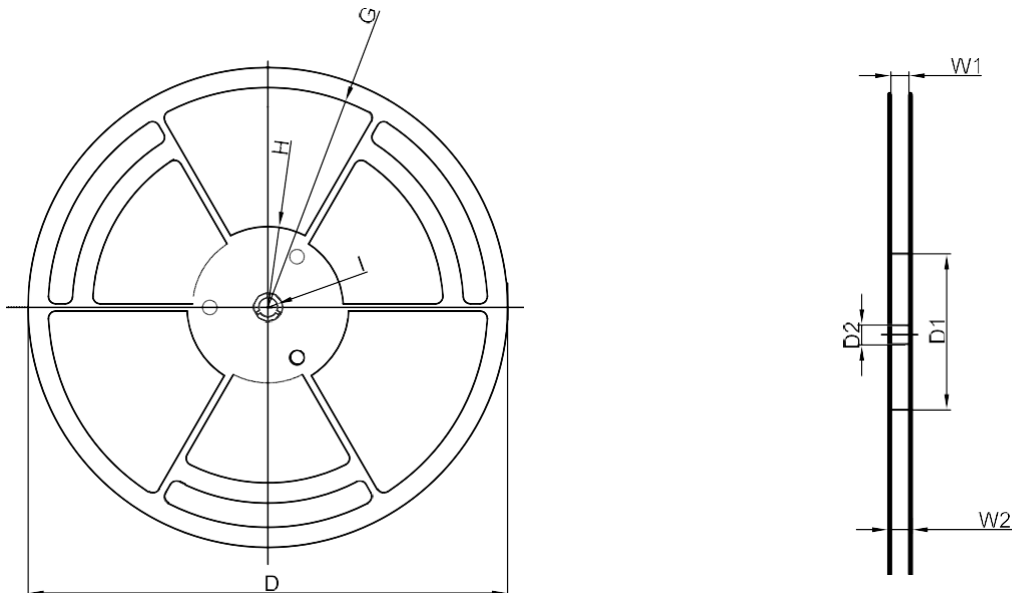

Dimensions are in millimeter								
Reel Option	D	D1	D2	G	H	I	W1	W2
13" Dia	Ø330.00	100.00	13.00	R151.00	R56.00	R6.50	12.40	17.60

REEL	Reel Size	Box	Box Size(mm)	Carton	Carton Size(mm)	G.W.(kg)
4,000 pcs	13 inch	8,000 pcs	360x360x65	64,000 pcs	565x380x390	