



## LMV321B, LMV358B and LMV324B CMOS Amplifiers

### 1 Introduction

The LMV321B/LMV358B/LMV324B family of single, dual, and quad channel operational amplifiers is specifically designed for general-purpose cost-sensitive systems and applications. Featuring rail-to-rail input and output (RRIO) swings, and low quiescent current (typical 85 $\mu$ A) combined with a wide bandwidth (1.2MHz) and low noise (30nV/ $\sqrt$ Hz at 1kHz) makes this family very attractive for a variety of battery-powered applications that require a good balance between cost and performance, such as audio outputs, consumer electronics, smoke detectors, portable medical devices and white goods. The low input bias current supports these amplifiers to be used in applications with mega-ohm source impedances.

The robust design of the LMV321B/LMV358B/LMV324B family provides ease-of-use to the circuit designer: unity-gain stability with capacitive loads of up to 500pF, integrated RF/EMI rejection filter, no phase reversal in overdrive conditions, and high electro-static discharge (ESD) protection (5kV HBM). The LMV321B/LMV358B/LMV324B amplifiers are optimized for operation at voltages as low as +1.8V ( $\pm$ 0.9V) and up to +5.5V ( $\pm$ 2.75V), and over the extended temperature range of  $-40^{\circ}$ C to  $+125^{\circ}$ C.

The LMV321B (single) is available in both SOT-23-5L package. The LMV358B (dual) is offered in SOP8, DFNWB2 $\times$ 2-8L and MSOP8 packages. The quad-channel LMV324B is offered in SOP14 and TSSOP14 package.

### 2 Features

- General Purpose Amplifiers for Cost-Sensitive Systems
- Low Input Offset Voltage:  
 $\pm$ 3.0mV (Max.)
- Low Noise: 30nV/ $\sqrt$ Hz at 1kHz
- 1.2MHz GBW for Unity-Gain Stable
- Micro-Power:  
85 $\mu$ A Supply Current Per Amplifier
- Single 1.8V to 5.5V Supply Voltage Range
- Rail-to-Rail Input and Output
- Internal RF/EMI Filter
- Extended Temperature Range:  
 $-40^{\circ}$ C to  $+125^{\circ}$ C

### 3 Applications

- Battery-Powered Instruments:  
Consumer, Industrial, Medical, Notebooks
- Audio Outputs
- Sensor Signal Conditioning:  
Sensor Interfaces, Loop-Powered, Active Filters
- Wireless Sensors:  
Home Security, Remote Sensing, Wireless Metering

### 4 Available Packages

PART NUMBER	PACKAGE
LMV321B-M5N	SOT-23-5L
LMV358B-PAN	SOP8
LMV358B-PDN	MSOP8
LMV358B-DCN	DFNWB2 $\times$ 2-8L
LMV324B-PHN	SOP14
LMV324B-PIN	TSSOP14

**5 Orderable Information**

MODEL	DEVICE	PACKAGE	OP TEMP	ECO PLAN	MSL	PACKING OPTION	SORT
LMV321B	LMV321B-M5N	SOT-23-5L	-40 ~ 125°C	RoHS & Green	Level 3 168 HR	Tape and Reel 3000 Units / Reel	Active
LMV358B	LMV358B-PAN	SOP8	-40 ~ 125°C	RoHS & Green	Level 3 168 HR	Tape and Reel 4000 Units / Reel	Active
	LMV358B-PDN	MSOP8	-40 ~ 125°C	RoHS & Green	Level 3 168 HR	Tape and Reel 4000 Units / Reel	Active
	LMV358B-DCN	DFNWB2×2-8L	-40 ~ 125°C	RoHS & Green	Level 3 168 HR	Tape and Reel 3000 Units / Reel	Active
LMV324B	LMV324B-PHN	SOP14	-40 ~ 125°C	RoHS & Green	Level 3 168 HR	Tape and Reel 2500 Units / Reel	Active
	LMV324B-PIN	TSSOP14	-40 ~ 125°C	RoHS & Green	Level 3 168 HR	Tape and Reel 3000 Units / Reel	Active
Others	-	-	-	-	-	-	Customized

**Note:**

**ECO PLAN:** For the RoHS and Green certification standards of this product, please refer to the official report provided by JSCJ.

**MSL:** Moisture Sensitivity Level. Determined according to JEDEC industry standard classification.

**SORT:** Specifically defined as follows:

Active: Recommended for new products;

Customized: Products manufactured to meet the specific needs of customers;

Preview: The device has been released and has not been fully mass produced. The sample may or may not be available;

NoRD: It is not recommended to use the device for new design. The device is only produced for the needs of existing customers; Obsolete: The device has been discontinued.

## 6 Pin Configuration and Marking Information

### 6.1 Pin Configuration and Function

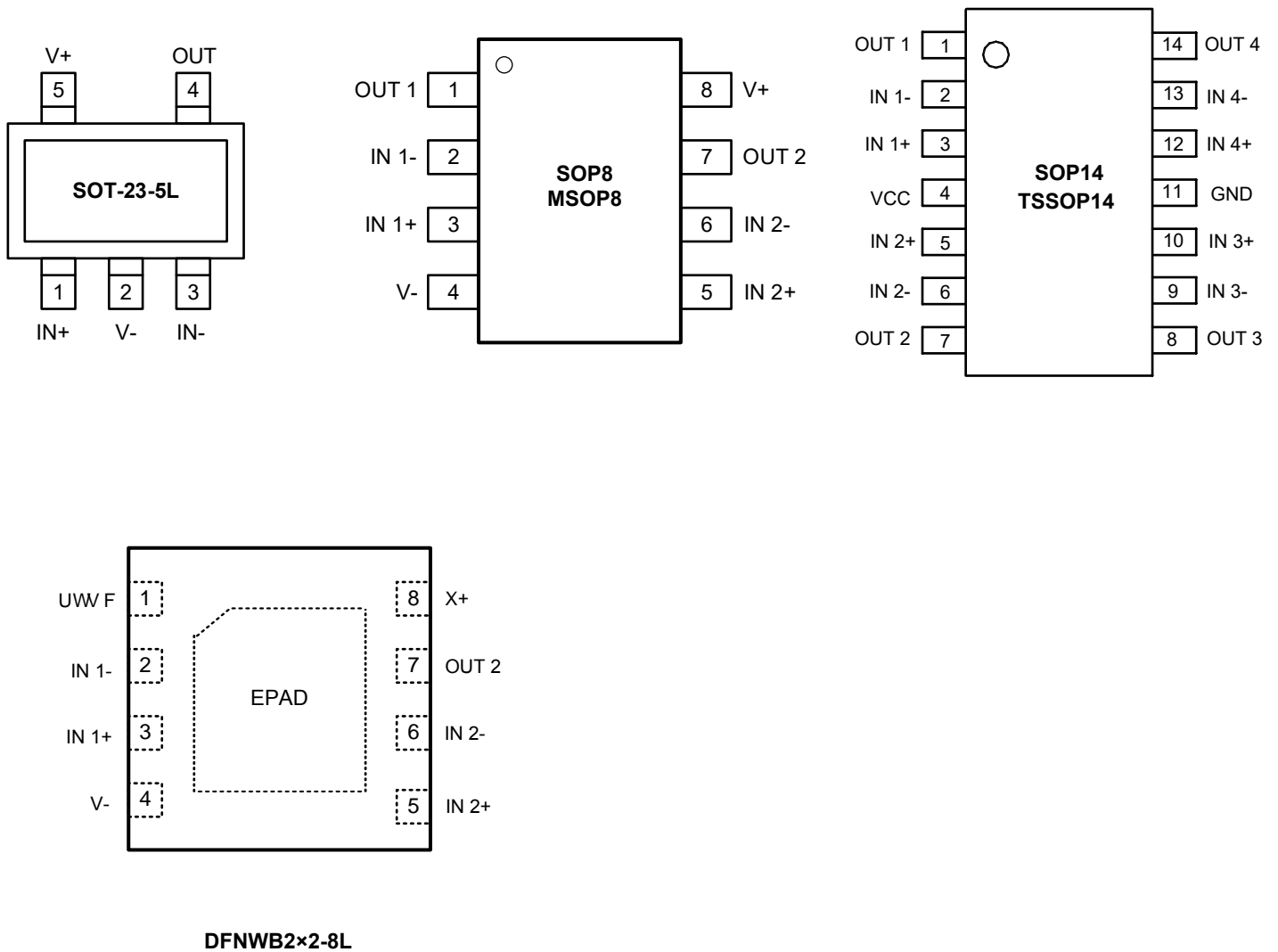

Figure 6-1. LMV321B, LMV358B and LMV324B Pin Map

## 6 Pin Configuration and Marking Information

### 6.1 Pin Configuration and Function (continued)

PIN NAME	LMV321B	LMV358B	LMV324B	I / O	DESCRIPTION
	SOT-23-5L	SOP8/MSOP8 DFNWB2×2-8L	SOP14/TSSOP14		
OUT1	4	1	1	O	Output of the operational amplifier 1.
IN1-	3	2	2	I	Negative input of the operational amplifier 1.
IN1+	1	3	3	I	Positive input of the operational amplifier 1.
V+	5	8	4	-	Positive (highest) supply.
IN2+	-	5	5	I	Positive input of the operational amplifier 2.
IN2-	-	6	6	I	Negative input of the operational amplifier 2.
OUT2	-	7	7	O	Output of the operational amplifier 2.
OUT3	-	-	8	O	Output of the operational amplifier 3.
IN3-	-	-	9	I	Negative input of the operational amplifier 3.
IN3+	-	-	10	I	Positive input of the operational amplifier 3.
V-	2	4	11	-	Negative (lowest) supply or ground for single supply.
IN4+	-	-	12	I	Positive input of the operational amplifier 4.
IN4-	-	-	13	I	Negative input of the operational amplifier 4.
OUT4	-	-	14	O	Output of the operational amplifier 4.
-	-	EPAD (DFNWB2×2-8L)	-	-	Exposed pad. Connected to GND or left floating.

6 Pin Configuration and Marking Information

6.2 Marking Information

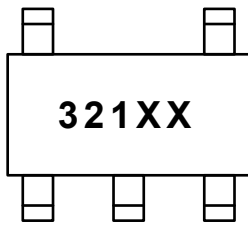

SOT-23-5L

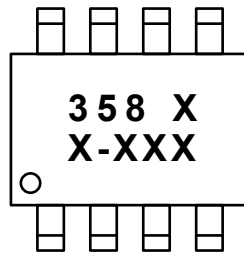

SOP8

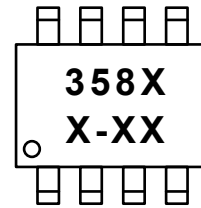

MSOP8

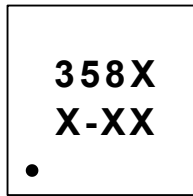

DFNWB2x2-8L

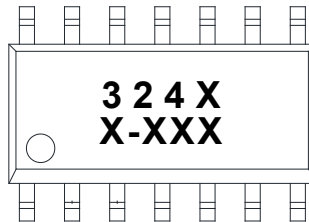

SOP14

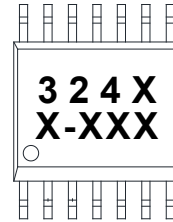

TSSOP14

"321, 358X and 324X": Device number.

"XX", "X-XXX", "X-XX": Code.

## 7 Specifications

### 7.1 Absolute Maximum Ratings

(over operating ambient temperature range, unless otherwise specified)<sup>(1)</sup>

CHARACTERISTIC		SYMBOL	VALUE	UNIT
Supply voltage[(V+) - (V-)]		V <sub>S</sub>	10	V
Signal input pins	Voltage <sup>(2)</sup>		(V-)-0.5V ~ (V+)+0.5V	V
	Current <sup>(2)</sup>		±10	mA
Output short-circuit		T <sub>sc</sub>	Continuous <sup>(3)</sup>	mA
Maximum junction temperature		T <sub>J MAX</sub>	150	°C
Storage temperature		T <sub>stg</sub>	-65 ~ 150	°C
Soldering temperature & time		T <sub>solder</sub>	260°C, 10s	-

(1) Stresses beyond those listed under *Absolute Maximum Ratings* may cause permanent damage to the device. These are stress ratings only, which do not imply functional operation of the device at these or any other conditions beyond those indicated under *Recommended Operating Conditions*. Exposure to absolute-maximum rated conditions for extended periods may affect device reliability.

(2) Input pins are diode-clamped to the power-supply rails. Current limit input signals that can swing more than 0.5V beyond the supply rails to 10mA or less.

(3) Short circuits from outputs to V<sub>S</sub> can cause excessive heating and eventual destruction. A heat sink may be required to keep the junction temperature below the absolute maximum. This depends on the power supply voltage and how many amplifiers are shorted. Thermal resistance varies with the amount of PC board metal connected to the package. The specified values are for short traces connected to the leads.

### 7.2 Recommend Operating Conditions

(over operating ambient temperature range, unless otherwise specified)

PARAMETER		SYMBOL	MIN.	NOM.	MAX.	UNIT
Power supply range	T <sub>A</sub> = -40 ~ 125°C	V <sub>S</sub>	1.8	-	5.5	V
Operating ambient temperature		T <sub>A</sub>	-40	-	125	°C

## 7 Specifications

### 7.3 ESD Ratings

ESD RATINGS		VALUE	UNIT
Electrostatic discharge	Human-body model (HBM), per ANSI/ESDA/JEDEC JS-001 <sup>(4)</sup>	5000	V
	Charged-device model (CDM), per JEDEC specification JESD22-C101 <sup>(5)</sup>	2000	
	Machine model (MM), per JESD22-A115C	250	

(4) JEDEC document JEP155 states that 500V HBM allows safe manufacturing with a standard ESD control process.

(5) JEDEC document JEP157 states that 250V CDM allows safe manufacturing with a standard ESD control process.

### 7.4 Thermal Information

THERMAL METRIC <sup>(6)</sup>	SYMBOL	LMV321B, LMV358B, LMV324B		UNIT
Junction-to-ambient thermal resistance	$R_{\theta JA}$	<b>SOT-23-5L</b>	<b>SOP8</b>	°C/W
		192.3	125.0	
		<b>MSOP8</b>	<b>SOP14</b>	
		201.6	115.7	
		<b>DFNWB2×2-8L</b>	<b>TSSOP14</b>	
		94.7	119.0	
Reference maximum power dissipation for continuous operation	$P_{D Ref}$	<b>SOT-23-5L</b>	<b>SOP8</b>	W
		0.65	1.00	
		<b>MSOP8</b>	<b>SOP14</b>	
		0.62	1.08	
		<b>DFNWB2×2-8L</b>	<b>TSSOP14</b>	
		1.32	1.05	

(6)  $T_A = 25^\circ\text{C}$ , measured on evaluation board with 1oz. copper traces of minimum pad size, all device outputs were active.

## 7 Specifications

### 7.5 Electrical Characteristics

( $V_S = (V+) - (V-) = 5.0V$ ,  $T_A = 25^\circ C$ ,  $V_{CM} = V_S / 2$ ,  $V_O = V_S / 2$ , and  $R_L = 10k\Omega$  connected to  $V_S / 2$ , unless otherwise noted. Boldface limits apply over the specified temperature range,  $T_A = -40$  to  $+125^\circ C$ .)

CHARACTERISTIC	SYMBOL	TEST CONDITIONS	MIN.	TYP.	MAX.	UNIT
<b>OFFSET VOLTAGE</b>						
Input offset voltage	$V_{OS}$	-	-	$\pm 0.7$	$\pm 3.0$	mV
Offset voltage drift	$V_{OS\ TC}$	$T_A = -40$ to $+125^\circ C$	-	1.0	3.5	$\mu V/^\circ C$
Power supply rejection ratio	PSRR	$V_S = 2.0$ to $5.5V$ , $V_{CM} < (V+) - 2V$ $T_A = -40$ to $+125^\circ C$	80	110	-	dB
			75	-	-	
<b>INPUT VOLTAGE</b>						
Common-mode voltage range	$V_{CM}$	-	$(V-) - 0.1$	-	$(V+) + 0.1$	V
Common-mode rejection ratio	CMRR	$V_S = 5.5V$ , $V_{CM} = -0.1$ to $5.6V$	70	83	-	dB
		$V_{CM} = 0$ to $5.3V$ , $T_A = -40$ to $+125^\circ C$	65	-	-	
		$V_S = 2.0V$ , $V_{CM} = -0.1$ to $2.1V$	65	77	-	
		$V_{CM} = 0$ to $1.8V$ , $T_A = -40$ to $+125^\circ C$	60	-	-	
<b>INPUT BIAS CURRENT</b>						
Input bias current	$I_B$	-	-	5	50	pA
		$T_A = +85^\circ C$	-	-	200	
		$T_A = +125^\circ C$	-	-	2000	
Input offset current	$I_{OS}$	-	-	10	50	pA
<b>NOISE</b>						
Input voltage noise	$E_n$	$f = 0.1$ to $10Hz$	-	6	-	$\mu V_{PP}$
Input voltage noise density	$e_n$	$f = 10kHz$	-	27	-	$nV/\sqrt{Hz}$
		$f = 1kHz$	-	30	-	
Input current noise density	$I_n$	$f = 1kHz$	-	5	-	$fA/\sqrt{Hz}$
<b>INPUT IMPEDANCE</b>						
Input capacitance	$C_{IN}$	Differential	-	2.0	-	pF
		Common mode	-	3.5	-	
<b>OPEN-LOOP GAIN</b>						
Open-loop voltage gain	$A_{VOL}$	$R_L = 50k\Omega$ , $V_O = 0.05$ to $3.5V$	90	105	-	dB
		$T_A = -40$ to $+125^\circ C$	85	-	-	
		$R_L = 2k\Omega$ , $V_O = 0.15$ to $3.5V$	85	100	-	
		$T_A = -40$ to $+125^\circ C$	80	-	-	

## 7 Specifications

### 7.5 Electrical Characteristics (continued)

( $V_S = (V+) - (V-) = 5.0V$ ,  $T_A = 25^\circ C$ ,  $V_{CM} = V_S / 2$ ,  $V_O = V_S / 2$ , and  $R_L = 10k\Omega$  connected to  $V_S / 2$ , unless otherwise noted. Boldface limits apply over the specified temperature range,  $T_A = -40$  to  $+125^\circ C$ .)

CHARACTERISTIC	SYMBOL	TEST CONDITIONS	MIN.	TYP.	MAX.	UNIT
<b>FREQUENCY RESPONSE</b>						
Gain bandwidth product	GBW	-	-	1.2	-	MHz
Slew rate	SR	$G = +1$ , $C_L = 100pF$ , $V_O = 1.5$ to $3.5V$	-	1	-	V/ $\mu s$
Total harmonic distortion + noise	THD+N	$G = +1$ , $f = 1kHz$ , $V_O = 1V_{RMS}$	-	0.003	-	%
Settling time	$t_s$	To 0.1%, $G = +1$ , 1V step	-	1.5	-	$\mu s$
		To 0.01%, $G = +1$ , 1V step	-	1.8	-	
Overload recovery time	$t_{OR}$	$V_{IN} \times \text{Gain} > V_S$	-	2.5	-	$\mu s$
<b>OUTPUT</b>						
High output voltage swing	$V_{OH}$	$R_L = 50k\Omega$	(V+)-6	(V+)-3	-	mV
		$R_L = 2k\Omega$	(V+)-100	(V+)-65	-	
Low output voltage swing	$V_{OL}$	$R_L = 50k\Omega$	-	(V-)+2	(V-)+4	mV
		$R_L = 2k\Omega$	-	(V-)+42	(V-)+65	
Short-circuit current	$I_{sc}$	Source current through $10\Omega$	-	40	-	mA
		Sink current through $10\Omega$	-	50	-	
<b>POWER SUPPLY</b>						
Quiescent current (per amplifier)	$I_Q$	-	-	85	120	$\mu A$
		$T_A = -40$ to $+125^\circ C$	-	-	150	

## 7 Specifications

### 7.6 Typical Characteristics

( $V_{CM} = V_S / 2$ , and  $R_L = 10k\Omega$  connected to  $V_S / 2$ ,  $T_A = 25^\circ C$ , unless otherwise specified)

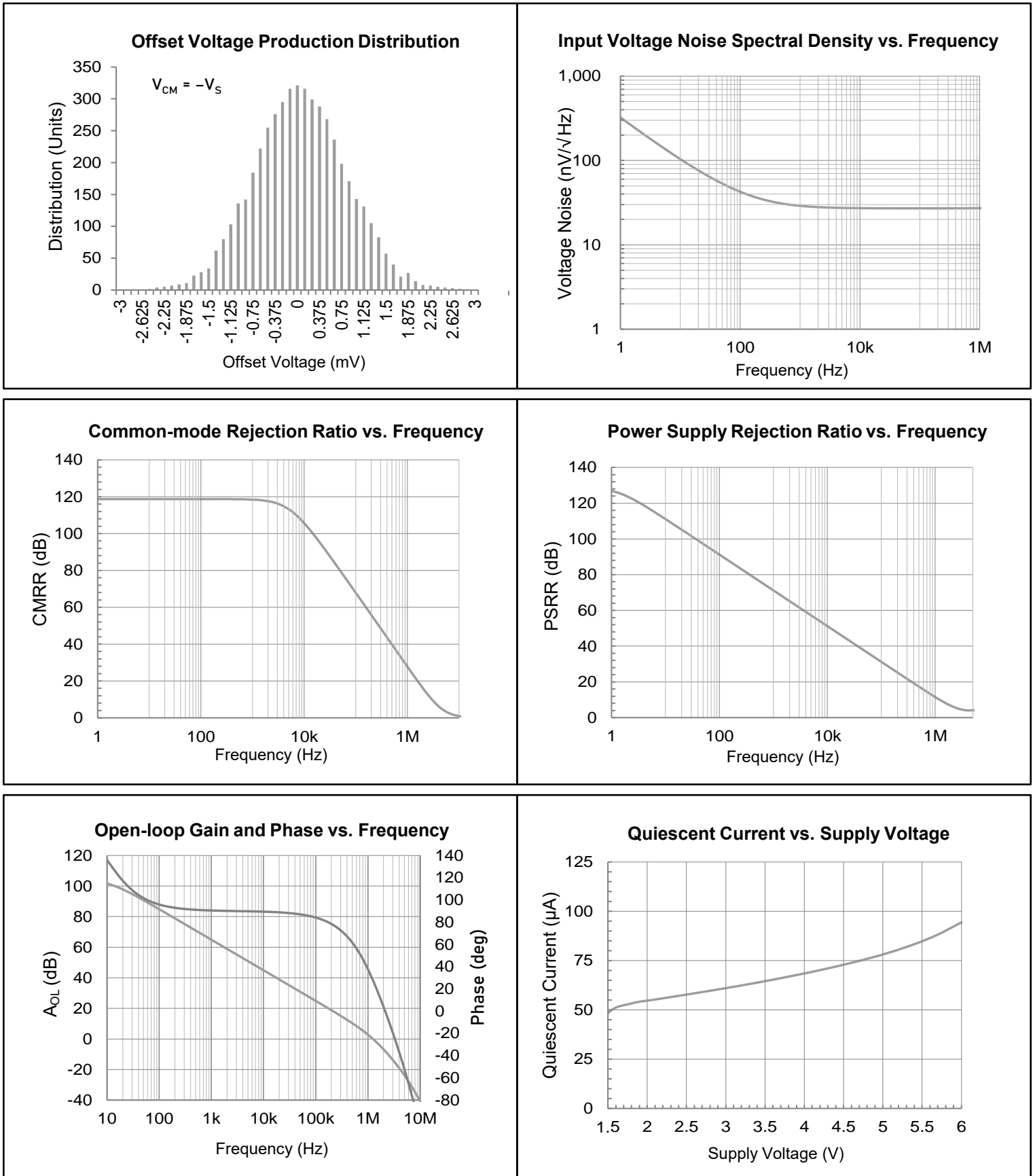

## 7 Specifications

### 7.6 Typical Characteristics (continued)

( $V_{CM} = V_S / 2$ , and  $R_L = 10k\Omega$  connected to  $V_S / 2$ ,  $T_A = 25^\circ C$ , unless otherwise specified)

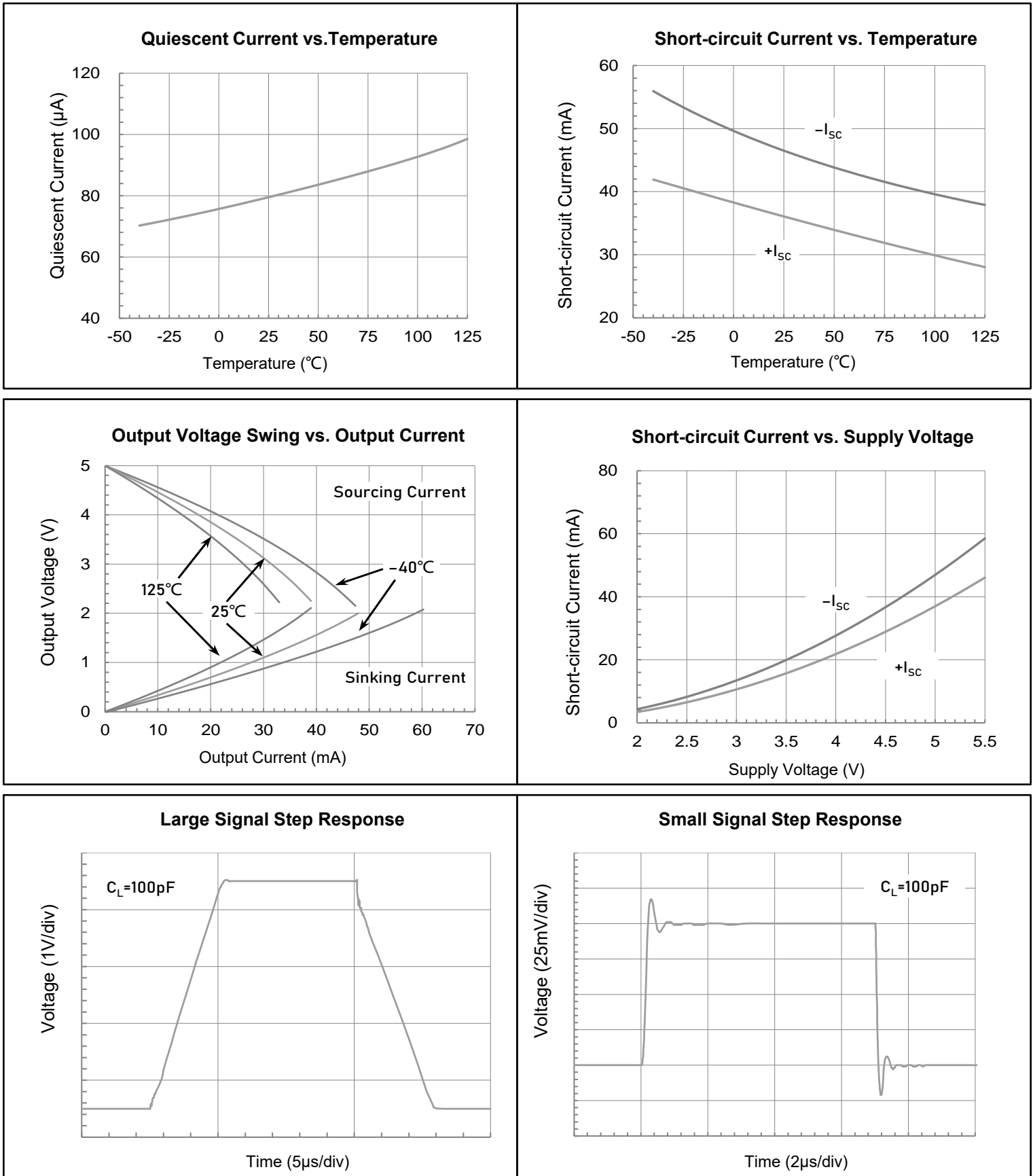

## 8 Detail Description

### 8.1 Description

The LMV321B/LMV358B/LMV324B is a family of low-power, rail-to-rail input and output operational amplifiers specifically designed for portable applications. These devices operate from 1.8V to 5.5V, are unity-gain stable, and suitable for a wide range of general-purpose applications. The class AB output stage is capable of driving  $\leq 10\text{k}\Omega$  loads connected to any point between  $V^+$  and ground. The input common-mode voltage range includes both rails, and allows the LMV321B/LMV358B/LMV324B family to be used in virtually any single-supply application. Rail-to-rail input and output swing significantly increases dynamic range, especially in low-supply applications, and makes them ideal for driving sampling analog-to-digital converters (ADCs).

### 8.2 Feature Description

#### Rail-to-Rail Input

The input common-mode voltage range of the LMV321B/LMV358B/LMV324B series extends 100mV beyond the negative and positive supply rails. This performance is achieved with a complementary input stage: an N-channel input differential pair in parallel with a P-channel differential pair. The N-channel pair is active for input voltages close to the positive rail, typically  $(V^+)-1.4\text{V}$  to the positive supply, whereas the P-channel pair is active for inputs from 100mV below the negative supply to approximately  $(V^+)-1.4\text{V}$ . There is a small transition region, typically  $(V^+)-1.2\text{V}$  to  $(V^+)-1\text{V}$ , in which both pairs are on. This 200mV transition region can vary up to 200mV with process variation. Thus, the transition region (both stages on) can range from  $(V^+)-1.4\text{V}$  to  $(V^+)-1.2\text{V}$  on the low end, up to  $(V^+)-1\text{V}$  to  $(V^+)-0.8\text{V}$  on the high end. Within this transition region, PSRR, CMRR, offset voltage, offset drift, and THD can be degraded compared to device operation outside this region.

The typical input bias current of the LMV321B/LMV358B/LMV324B during normal operation is approximately 5pA. In overdriven conditions, the bias current can increase significantly. The most common cause of an overdriven condition occurs when the operational amplifier is outside of the linear range of operation. When the output of the operational amplifier is driven to one of the supply rails, the feedback loop requirements cannot be satisfied and a differential input voltage develops across the input pins. This differential input voltage results in activation of parasitic diodes inside the front-end input chopping switches that combine with electromagnetic interference (EMI) filter resistors to create the equivalent circuit. Notice that the input bias current remains within specification in the linear region.

#### Rail-to-Rail Output

Designed as a micro-power, low-noise operational amplifier, the LMV321B/LMV358B/LMV324B delivers a robust output drive capability. A class AB output stage with common-source transistors is used to achieve full rail-to-rail output swing capability. For resistive loads up to  $50\text{k}\Omega$ , the output swings typically to within 3mV of either supply rail regardless of the power-supply voltage applied. Different load conditions change the ability of the amplifier to swing close to the rails. For resistive loads up to  $2\text{k}\Omega$ , the output swings typically to within 65mV of the positive supply rail and within 42mV of the negative supply rail.

## 8 Detail Description

### 8.2 Feature Description (continued)

#### Overload Recovery

Overload recovery is defined as the time required for the operational amplifier output to recover from a saturated state to a linear state. The output devices of the operational amplifier enter a saturation region when the output voltage exceeds the rated operating voltage, either because of the high input voltage or the high gain. After the device enters the saturation region, the charge carriers in the output devices require time to return back to the linear state. After the charge carriers return back to the linear state, the device begins to slew at the specified slew rate. Thus, the propagation delay in case of an overload condition is the sum of the overload recovery time and the slew time. The overload recovery time for the LMV321B, LMV358B and LMV324B family is approximately 2.5 $\mu$ s.

#### EMI Rejection

Circuit performance is often adversely affected by high frequency EMI. When the signal strength is low and transmission lines are long, an op-amp must accurately amplify the input signals. However, all op-amp pins — the non-inverting input, inverting input, positive supply, negative supply, and output pins — are susceptible to EMI signals. These high frequency signals are coupled into an op-amp by various means, such as conduction, near field radiation, or far field radiation. For example, wires and printed circuit board (PCB) traces can act as antennas and pick up high frequency EMI signals. Amplifiers do not amplify EMI or RF signals due to their relatively low bandwidth. However, due to the nonlinearities of the input devices, op-amps can rectify these out of band signals. When these high frequency signals are rectified, they appear as a dc offset at the output.

The LMV321B, LMV358B and LMV324B op-amps have integrated EMI filters at their input stage. A mathematical method of measuring EMIRR is defined as follows:

$$EMIRR = 20 \log(V_{IN\_PEAK} / \Delta V_{OS})$$

## 9 Application and Implementation

### 9.1 Application Information

The LMV321B/LMV358B/LMV324B features 1.2MHz bandwidth and 1V/ $\mu$ s slew rate with only 85 $\mu$ A supply current per amplifier, providing good ac performance at very low power consumption. DC applications are also well served with a low input noise voltage of 30nV/ $\sqrt{\text{Hz}}$  at 1kHz, low input bias current, and an input offset voltage of  $\pm 3.0\text{mV}$  maximum. The typical offset voltage drift is 1 $\mu\text{V}/^\circ\text{C}$ , over the full temperature range the input offset voltage changes only 100 $\mu\text{V}$  (0.7mV to 0.8mV).

### 9.2 Typical Application Circuits

#### Input EMI Filter and Clamp Circuit

Figure 9-1 shows the input EMI filter and clamp circuit. The LMV321B/LMV358B/LMV324B op-amps have internal ESD protection diodes (D1, D2, D3, and D4) that are connected between the inputs and each supply rail. These diodes protect the input transistors in the event of electrostatic discharge and are reverse biased during normal operation. This protection scheme allows voltages as high as approximately 500mV beyond the rails to be applied at the input of either terminal without causing permanent damage. These ESD protection current-steering diodes also provide in-circuit, input overdrive protection, as long as the current is limited to 20mA as stated in the Absolute Maximum Ratings.

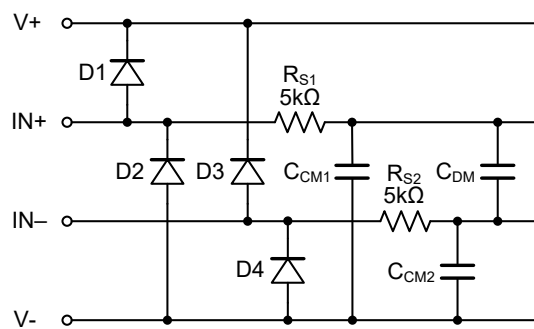

Figure 9-1. Input EMI Filter and Clamp Circuit

Operational amplifiers vary in susceptibility to EMI. If conducted EMI enters the operational amplifier, the dc offset at the amplifier output can shift from its nominal value when EMI is present. This shift is a result of signal rectification associated with the internal semiconductor junctions. Although all operational amplifier pin functions can be affected by EMI, the input pins are likely to be the most susceptible. The EMI filter of the LMV321B/LMV358B/LMV324B family is composed of two 5k $\Omega$  input series resistors ( $R_{S1}$  and  $R_{S2}$ ), two common-mode capacitors ( $C_{CM1}$  and  $C_{CM2}$ ), and a differential capacitor ( $C_{DM}$ ). These RC networks set the -3dB low-pass cutoff frequencies at 35MHz for common-mode signals, and at 22MHz for differential signals.

## 9 Application and Implementation

### 9.2 Typical Application Circuits (continued)

#### Capacitive Load and Stability

The LMV321B/LMV358B/LMV324B family can safely drive capacitive loads of up to 500pF in any configuration. As with most amplifiers, driving larger capacitive loads than specified may cause excessive overshoot and ringing, or even oscillation. A heavy capacitive load reduces the phase margin and causes the amplifier frequency response to peak. Peaking corresponds to over-shooting or ringing in the time domain. Therefore, it is recommended that external compensation be used if the LMV321B/LMV358B/LMV324B op-amps must drive a load exceeding 500pF. This compensation is particularly important in the unity-gain configuration, which is the worst case for stability.

A quick and easy way to stabilize the op-amp for capacitive load drive is by adding a series resistor,  $R_{ISO}$ , between the amplifier output terminal and the load capacitance, as shown in Figure 9-2.  $R_{ISO}$  isolates the amplifier output and feedback network from the capacitive load. The bigger the  $R_{ISO}$  resistor value, the more stable  $V_{OUT}$  will be. Note that this method results in a loss of gain accuracy because  $R_{ISO}$  forms a voltage divider with the  $R_L$ .

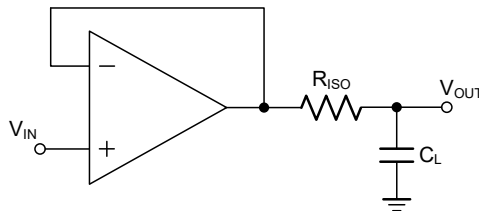

Figure 9-2. Indirectly Driving Heavy Capacitive Load

An improvement circuit is shown in Figure 9-3. It provides DC accuracy as well as AC stability. The  $R_F$  provides the DC accuracy by connecting the inverting signal with the output.

The  $C_F$  and  $R_{ISO}$  serve to counteract the loss of phase margin by feeding the high frequency component of the output signal back to the amplifier's inverting input, thereby preserving phase margin in the overall feedback loop.

For no-buffer configuration, there are two others ways to increase the phase margin: (a) by increasing the amplifier's gain, or (b) by placing a capacitor in parallel with the feedback resistor to counteract the parasitic capacitance associated with inverting node.

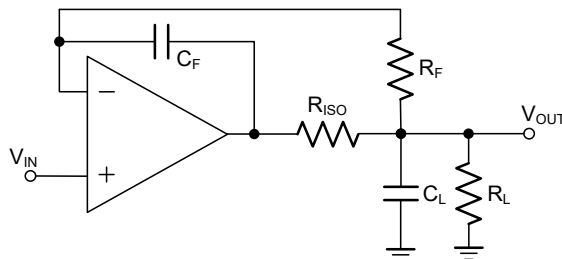

Figure 9-3. Indirectly Driving Heavy Capacitive Load with DC Accuracy

#### Input-to-Output Coupling

To minimize capacitive coupling, the input and output signal traces should not be parallel. This helps reduce unwanted positive feedback.

## 9 Application and Implementation

### 9.3 Power Supply Recommendations

The LMV321B/LMV358B/LMV324B family is optimized for operation at voltages as low as +1.8V ( $\pm 0.9V$ ) and up to +5.5V ( $\pm 2.75V$ ). In addition, many specifications apply from  $-40^{\circ}\text{C}$  to  $+125^{\circ}\text{C}$ . Parameters that vary significantly with operating voltages or temperature are illustrated in the Typical Characteristics graphs.

NOTE: Supply voltages ( $V+$  to  $V-$ ) higher than +10V can permanently damage the device.

### 9.4 Layout Guidelines

To achieve the maximum performance of the extremely high input impedance and low offset voltage of the LMV321B/LMV358B/LMV324B op-amps, care is needed in laying out the circuit board. The PCB surface must remain clean and free of moisture to avoid leakage currents between adjacent traces. Surface coating of the circuit board reduces surface moisture and provides a humidity barrier, reducing parasitic resistance on the board. The use of guard rings around the amplifier inputs further reduces leakage currents. Figure 9-4 shows proper guard ring configuration and the top view of a surface-mount layout. The guard ring does not need to be a specific width, but it should form a continuous loop around both inputs. By setting the guard ring voltage equal to the voltage at the non-inverting input, parasitic capacitance is minimized as well. For further reduction of leakage currents, components can be mounted to the PCB using Teflon standoff insulators.

Other potential sources of offset error are thermoelectric voltages on the circuit board. This voltage, also called Seebeck voltage, occurs at the junction of two dissimilar metals and is proportional to the temperature of the junction. The most common metallic junctions on a circuit board are solder-to-board trace and solder-to-component lead. If the temperature of the PCB at one end of the component is different from the temperature at the other end, the resulting Seebeck voltages are not equal, resulting in a thermal voltage error.

This thermocouple error can be reduced by using dummy components to match the thermoelectric error source. Placing the dummy component as close as possible to its partner ensures both Seebeck voltages are equal, thus canceling the thermocouple error. Maintaining a constant ambient temperature on the circuit board further reduces this error. The use of a ground plane helps distribute heat throughout the board and reduces EMI noise pickup.

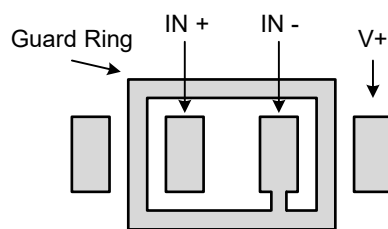
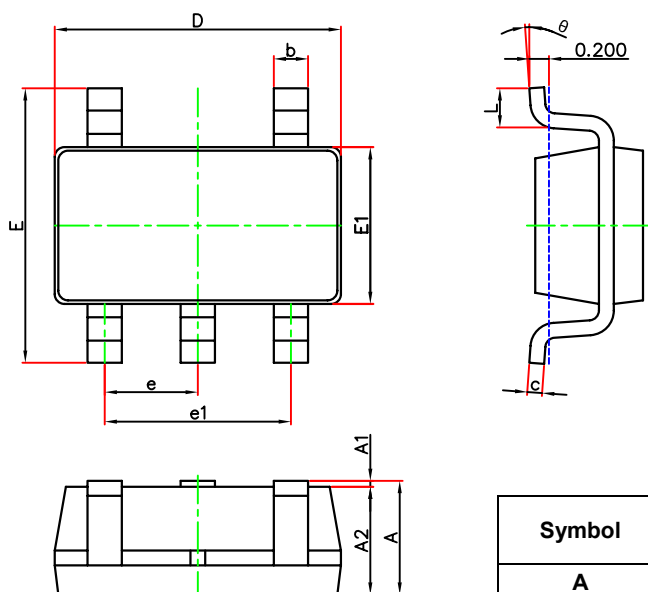

Figure 9-4. Guard Ring

## 10 Mechanical Information

### 10.1 SOT-23-5L Mechanical Information

#### SOT-23-5L Outline Dimensions



Symbol	Dimensions In Millimeters		Dimensions In Inches	
	Min.	Max.	Min.	Max.
A	1.050	1.250	0.041	0.049
A1	0.000	0.100	0.000	0.004
A2	1.000	1.200	0.039	0.047
b	0.300	0.500	0.012	0.020
c	0.100	0.200	0.004	0.008
D	2.820	3.020	0.111	0.119
E	2.600	3.000	0.102	0.118
E1	1.500	1.700	0.059	0.067
e	0.950(BSC)		0.037(BSC)	
e1	1.800	2.000	0.071	0.079
L	0.300	0.600	0.012	0.024
θ	0°	8°	0°	8°

#### SOT-23-5L Suggested Pad Layout

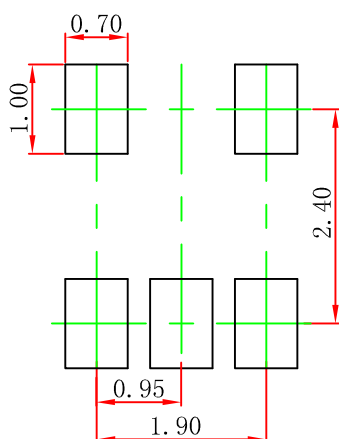

**Note:**

1. Controlling dimension: in millimeters.
2. General tolerance: ±0.05mm.
3. The pad layout is for reference purpose only.

## 10 Mechanical Information

### 10.2 SOP8 Mechanical Information

#### Outline Dimensions

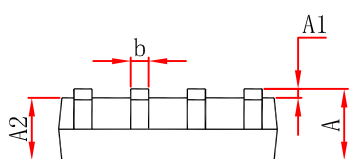
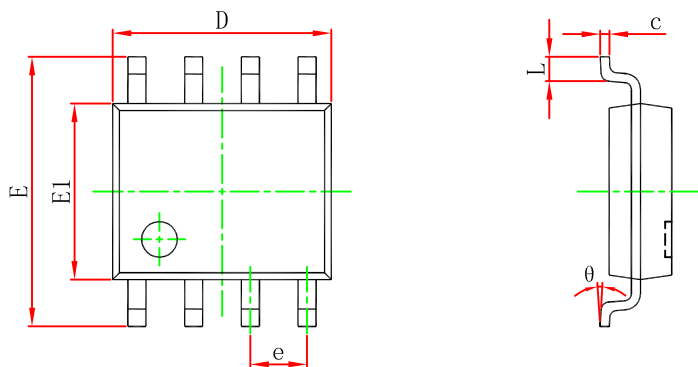

Symbol	Dimensions In Millimeters		Dimensions In Inches	
	Min	Max	Min	Max
A	1.370	1.670	0.054	0.066
A1	0.070	0.250	0.003	0.010
A2	1.350	1.550	0.053	0.061
b	0.300	0.510	0.013	0.020
c	0.170	0.250	0.007	0.010
D	4.700	5.100	0.185	0.201
e	1.270 (BSC)		0.050 (BSC)	
E	5.800	6.200	0.228	0.244
E1	3.800	4.000	0.150	0.157
L	0.400	1.270	0.016	0.050
θ	0°	8°	0°	8°

#### SOP8 Suggest Pad Layout

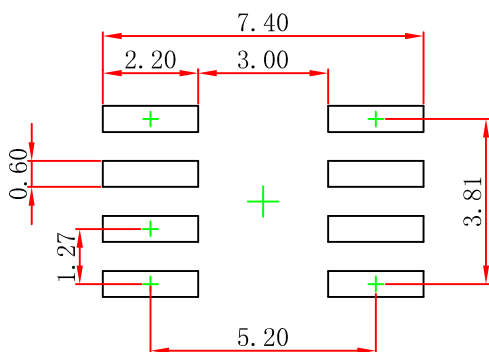

#### NOTE:

1. Controlling dimension: in millimeters.
2. General tolerance:  $\pm 0.05\text{mm}$ .
3. The pad layout is for reference purposes only.

10 Mechanical Information

10.3 MSOP8 Mechanical Information

Outline Dimensions

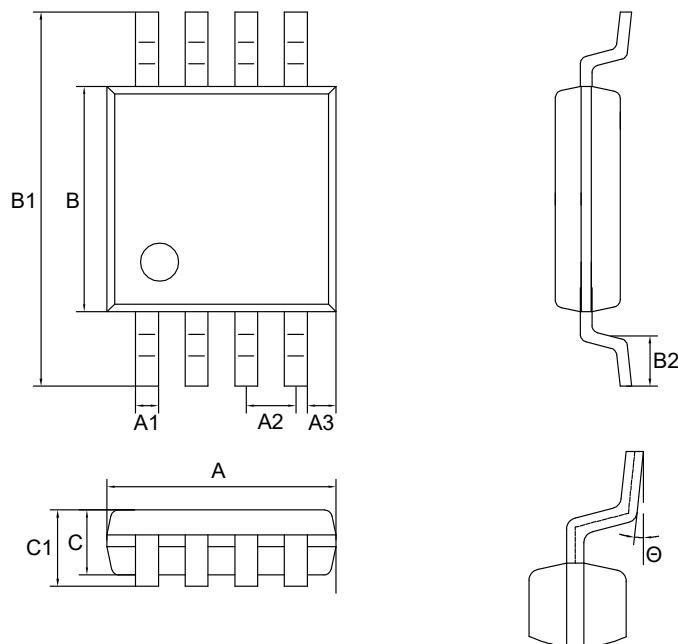

SYMBOL	DISMENSIONS IN MILLIMETERS			DISMENSIONS IN INCHES		
	MIN	NOM	MAX	MIN	NOM	MAX
A	2.900	3.000	3.100	0.114	0.118	0.122
A1	0.280	-	0.350	0.011	-	0.014
A2	0.650 TYP.			0.026 TYP.		
B	2.900	3.000	3.100	0.114	0.118	0.122
B1	4.700	-	5.100	0.185	-	0.201
B2	0.450	0.600	0.750	0.018	0.024	0.030
C	0.750	0.850	0.950	0.030	0.033	0.037
C1	-	-	1.100	-	-	0.043
Θ	0°	-	6°	0°	-	6°

10 Mechanical Information

10.4 SOP14 Mechanical Information

Outline Dimensions

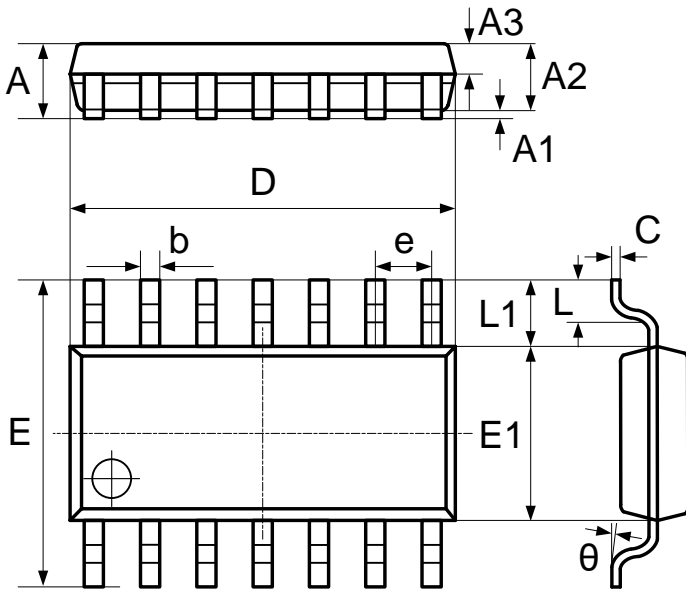

SYMBOL	DISMENSIONS IN MILLIMETERS			DISMENSIONS IN INCHES		
	MIN	NOM	MAX	MIN	NOM	MAX
A	1.450	1.650	1.850	0.057	0.065	0.073
A1	0.100	0.200	0.300	0.004	0.008	0.012
A2	1.350	1.450	1.550	0.053	0.057	0.061
A3	0.550	0.650	0.750	0.022	0.026	0.030
b	0.406 TYP.			0.016 TYP.		
C	0.203 TYP.			0.008 TYP.		
D	8.630	8.730	8.830	0.340	0.344	0.348
E	5.840	6.040	6.240	0.230	0.238	0.246
E1	3.850	3.950	4.050	0.152	0.156	0.159
e	1.270 TYP.			0.050 TYP.		
L1	1.040 REF.			0.041 REF.		
L	0.350	0.550	0.750	0.014	0.022	0.030
θ	2°	5°	8°	2°	5°	8°

SOP14 Suggest Pad Layout

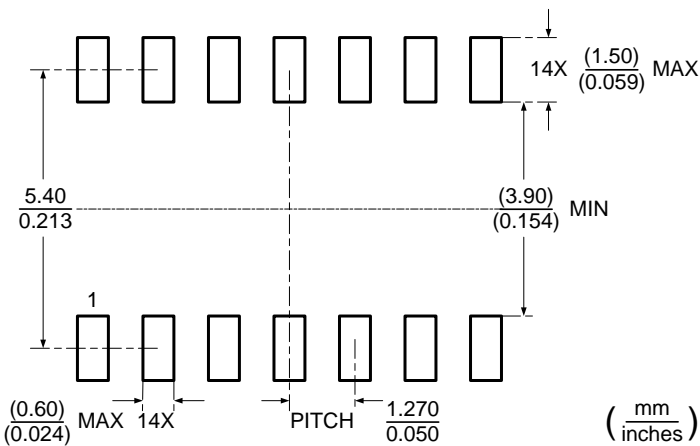

NOTE:

1. Controlling dimension: in millimeters.
2. General tolerance: ±0.05mm.
3. The pad layout is for reference purposes only.



10 Mechanical Information

10.6 TSSOP14 Mechanical Information

Outline Dimensions

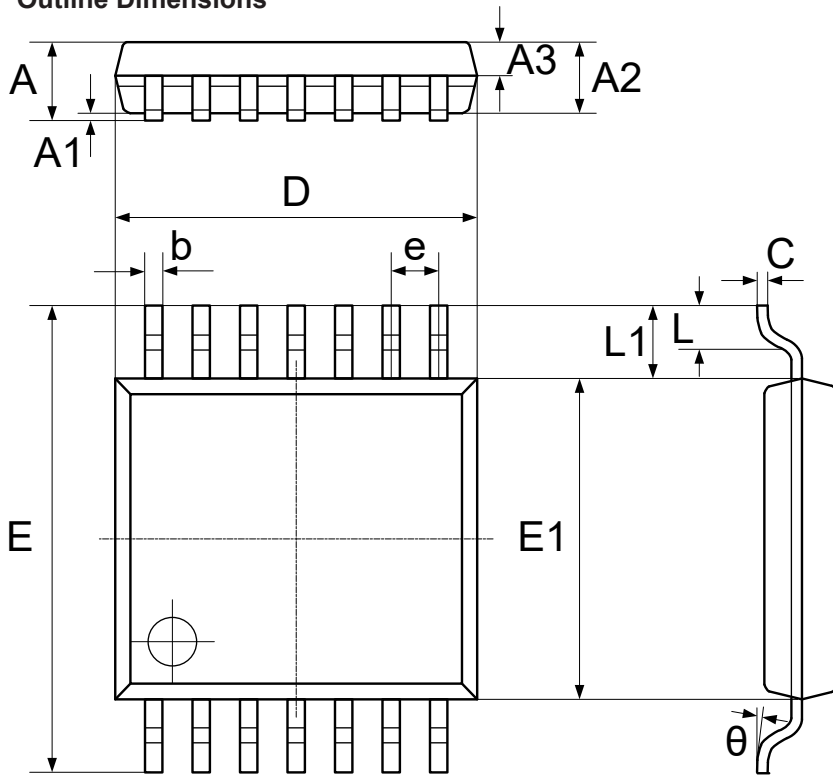

Symbol	Dimensions In Millimeters		Dimensions In Inches	
	Min	Max	Min	Max
A	-	1.200	-	0.047
A1	0.050	0.150	0.002	0.006
A2	0.900	1.050	0.035	0.041
A3	0.390	0.490	0.015	0.019
b	0.200	0.290	0.008	0.011
C	0.130	0.180	0.005	0.007
D	4.860	5.060	0.191	0.199
E	6.200	6.600	0.244	0.260
E1	4.300	4.500	0.169	0.177
e	0.650 TYP.		0.026 TYP.	
L1	1.000 REF.		0.039 REF.	
L	0.450	0.750	0.018	0.030
theta	0°	8°	0°	8°

TSSOP14 Suggest Pad Layout

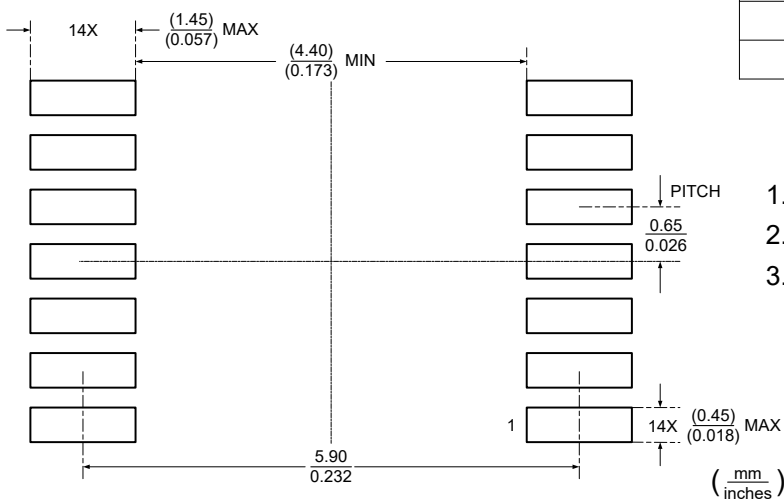

NOTE:

1. Controlling dimension: in millimeters.
2. General tolerance: ±0.05mm.
3. The pad layout is for reference purposes only.

## 11 Packaging Information

### 11.1 SOT-23-5L Tape and Reel Information

#### SOT-23-5L Tape and Reel Information

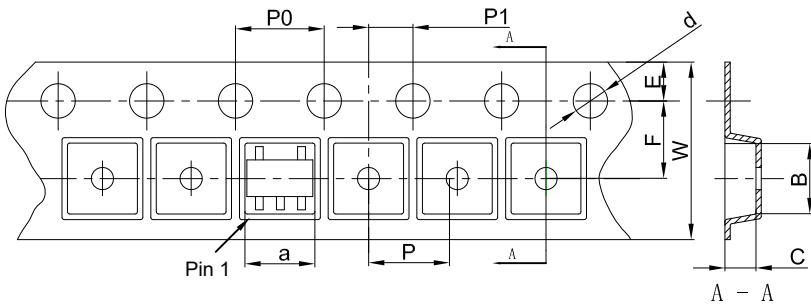

**Packaging Description:**

SOT-23-5L parts are shipped in tape. The carrier tape is made from a dissipative (carbon filled) polycarbonate resin. The cover tape is a multilayer film (Heat Activated Adhesive in nature) primarily composed of polyester film, adhesive layer, sealant, and anti-static sprayed agent. These reeled parts in standard option are shipped with 3,000 units per 7" or 18.0cm diameter reel. The reels are clear in color and is made of polystyrene plastic (anti-static coated).

Dimensions are in millimeter										
Pkg type	a	B	C	d	E	F	P0	P	P1	W
SOT-23-5L	3.17	3.23	1.37	Ø1.55	1.75	3.50	4.00	4.00	2.00	8.00

#### SOT-23-5L Tape Leader and Trailer

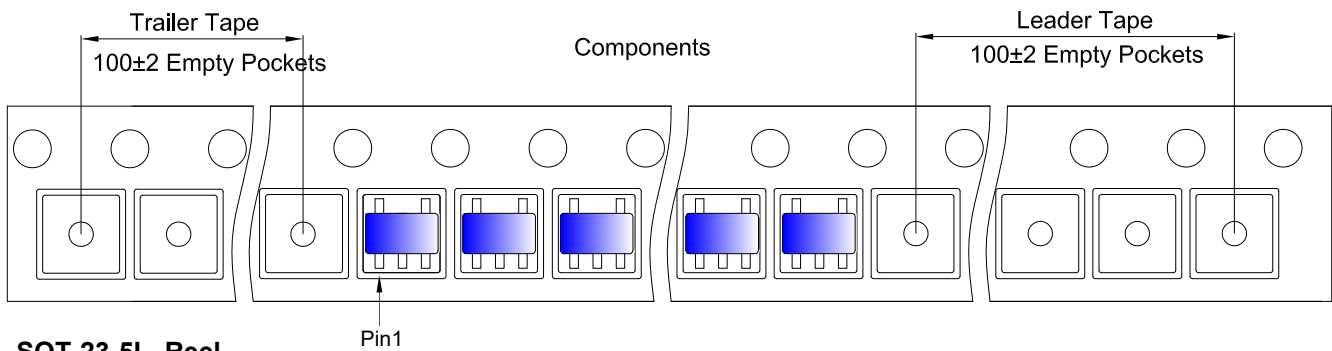

#### SOT-23-5L Reel

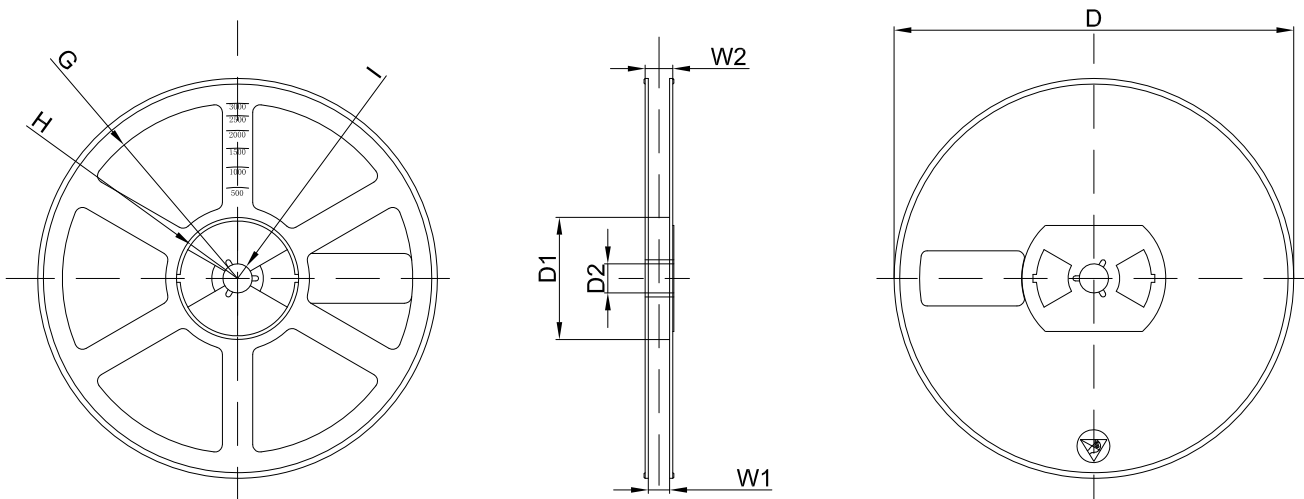

Dimensions are in millimeter								
Reel Option	D	D1	D2	G	H	I	W1	W2
7" Dia	Ø180.00	60.00	13.00	R78.00	R25.60	R6.50	9.50	13.10

REEL	Reel Size	Box	Box Size(mm)	Carton	Carton Size(mm)	G.W.(kg)
3000 pcs	7 inch	30,000 pcs	203×203×195	120,000 pcs	438×438×220	

# 11 Packaging Information

## 11.2 SOP8 Tape and Reel Information

### Embossed Carrier Tape

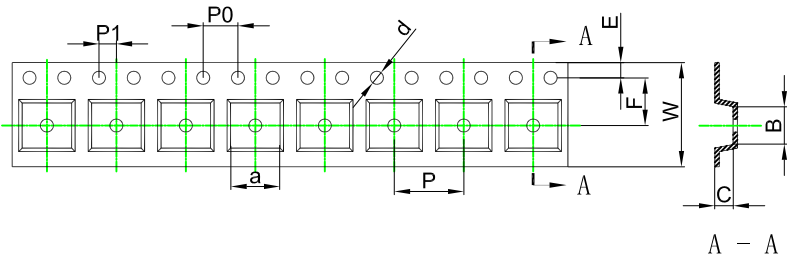

**Packaging Description:**  
 SOP8 parts are shipped in tape. The carrier tape is made from a dissipative (carbon filled) polycarbonate resin. The cover tape is a multilayer film (Heat Activated Adhesive in nature) primarily composed of polyester film, adhesive layer, sealant, and anti-static sprayed agent. These reeled parts in standard option are shipped with 2,500 units per 13" or 33cm diameter reel. The reels are clear in color and is made of polystyrene plastic (anti-static coated).  
**ALL DIM IN mm**

Dimensions are in millimeter										
Pkg type	a	B	C	d	E	F	P0	P	P1	W
SOP8	6.40	5.40	2.10	Ø1.50	1.75	5.50	4.00	8.00	2.00	12.00

### Tape Leader and Trailer

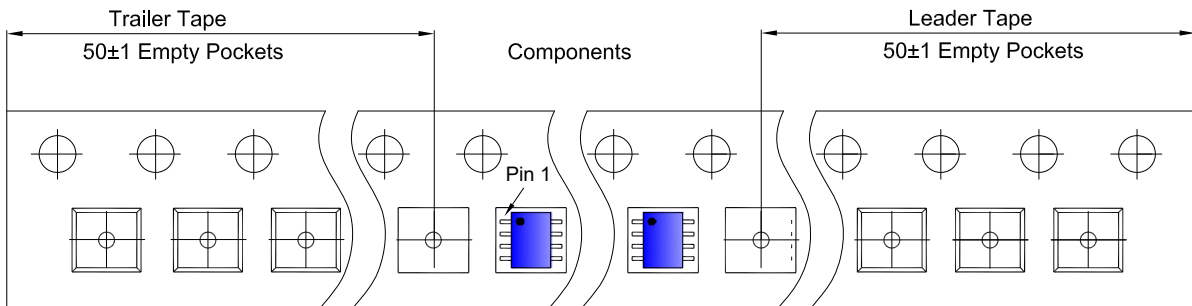

### Reel

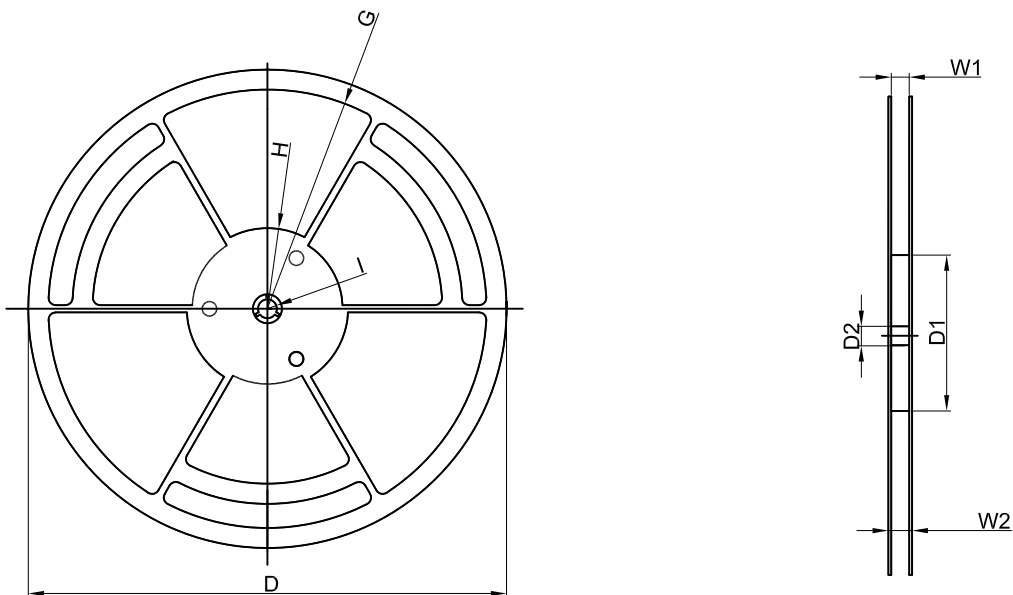

Dimensions are in millimeter								
Reel Option	D	D1	D2	G	H	I	W1	W2
13" Dia	Ø330.00	100.00	13.00	R151.00	R56.00	R6.50	12.40	17.60

REEL	Reel Size	Box	Box Size(mm)	Carton	Carton Size(mm)	G.W.(kg)
4,000 pcs	13 inch	8,000 pcs	360×360×65	64,000 pcs	565×380×390	

## 12 Notes and Revision History

### 12.1 Associated Product Family and Others

To view other products of the same type or IC products of other types, click the official website of JSCJ -- <https://www.jscj-elec.com> for more details.

### 12.2 Notes

#### Electrostatic Discharge Caution



This IC may be damaged by ESD. Relevant personnel shall comply with correct installation and use specifications to avoid ESD damage to the IC. If appropriate measures are not taken to prevent ESD damage, the hazards caused by ESD include but are not limited to degradation of integrated circuit performance or complete damage of integrated circuit. For some precision integrated circuits, a very small parameter change may cause the whole device to be inconsistent with its published specifications.

### 12.3 Revision History

**June 2025:** changed from rev - 1.0 to rev - 1.1: Added LMV324B-PIN for TSSOP14 package in the datasheet.

**December 2024:** released LMV321B, LMV358B and LMV324B rev - 1.0.

# DISCLAIMER

## **IMPORTANT NOTICE, PLEASE READ CAREFULLY**

The information in this data sheet is intended to describe the operation and characteristics of our products. JSCJ has the right to make any modification, enhancement, improvement, correction or other changes to any content in this data sheet, including but not limited to specification parameters, circuit design and application information, without prior notice.

Any person who purchases or uses JSCJ products for design shall: 1. Select products suitable for circuit application and design; 2. Design, verify and test the rationality of circuit design; 3. Procedures to ensure that the design complies with relevant laws and regulations and the requirements of such laws and regulations. JSCJ makes no warranty or representation as to the accuracy or completeness of the information contained in this data sheet and assumes no responsibility for the application or use of any of the products described in this data sheet.

Without the written consent of JSCJ, this product shall not be used in occasions requiring high quality or high reliability, including but not limited to the following occasions: medical equipment, military facilities and aerospace. JSCJ shall not be responsible for casualties or property losses caused by abnormal use or application of this product.

Official Website: [www.jscj-elec.com](http://www.jscj-elec.com)

Copyright © JIANGSU CHANGJING ELECTRONICS TECHNOLOGY CO., LTD.