

MBF Plastic-Encapsulate Bridge Rectifier

MB05F THRU MB10F General Purpose Bridge Rectifier

Features

- $I_{F(AV)}$ 0.8A
- V_{RRM} 50V-1000V
- High surge current capability
- Glass passivated chip

Applications

- General purpose 1 phase Bridge rectifier applications

Marking

- MBXXF

X : From 05 To 10

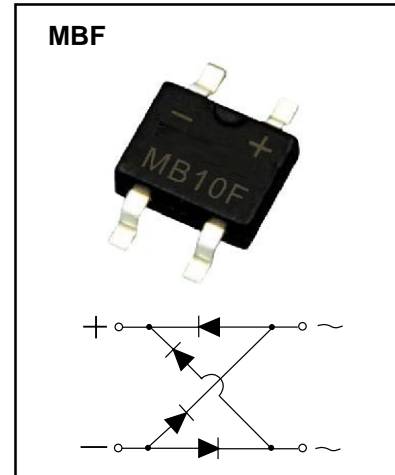

Limiting Values (Absolute Maximum Rating)

Item	Symbol	Unit	Conditions	MB						
				05F	1F	2F	4F	6F	8F	10F
Repetitive Peak Reverse Voltage	V_{RRM}	V		50	100	200	400	600	800	1000
Maximum RMS Voltage	V_{RMS}	V		35	70	140	280	420	560	700
Maximum DC blocking Voltage	V_{DC}	V		50	100	200	400	600	800	1000
Average Rectified Output Current	I_o	A	60Hz sine wave, R-load, $T_a=25^\circ C$	On alumina substrate						
				On glass-epoxi substrate						
Surge(Non-repetitive)Forward Current	I_{FSM}	A	60Hz half sine wave, 1 cycle, $T_j=25^\circ C$	30						
Current Squared Time	I^2t	A ² S	$1ms \leq t < 8.3ms$ $T_j=25^\circ C$, Rating of per diode	3.7						
Operation Junction and Storage Temperature Range	T_j, T_{stg}	$^\circ C$		-55 ~+150						

Electrical Characteristics ($T_a=25^\circ C$ Unless otherwise specified)

Item	Symbol	Unit	Test Condition	Max
Peak Forward Voltage	V_{FM}	V	$I_{FM}=0.4A$, Pulse measurement, Rating of per diode	1.0
Peak Reverse Current	I_{RRM1}	μA	Maximum DC reverse current $T_a=25^\circ C$	5.0
	I_{RRM2}	μA	at rated DC blocking voltage $T_a=125^\circ C$	500
Thermal Resistance	$R_{\theta J-A}$	$^\circ C/W$	Between junction and ambient, On alumina substrate	75
			Between junction and ambient, On glass-epoxi substrate	134
	$R_{\theta J-L}$		Between junction and lead	20
Typical junction capacitance per diode	C_J	pF	Measured at 1.0MHz and applied reverse voltage of 4.0 volts.	13

Typical Characteristics

FIG.1: FORWARD CURRENT DERATING CURVE

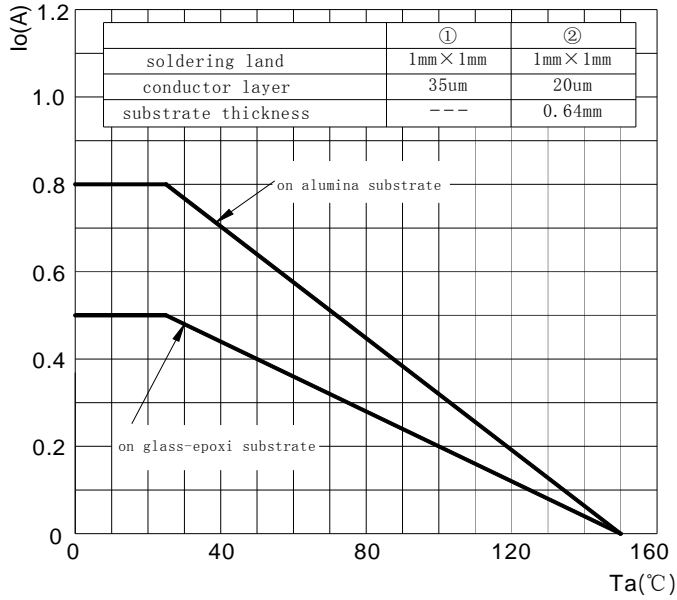

FIG.2: MAXIMUM NON-REPETITIVE FORWARD SURGE CURRENT

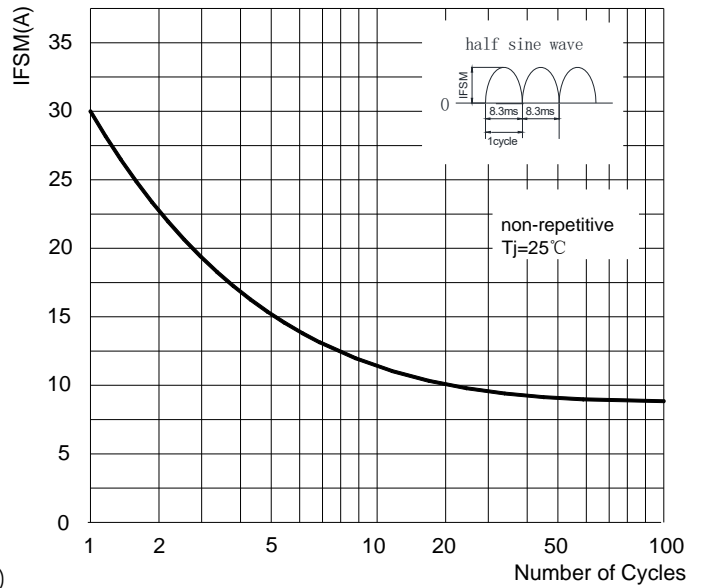

FIG.3: TYPICAL FORWARD CHARACTERISTICS

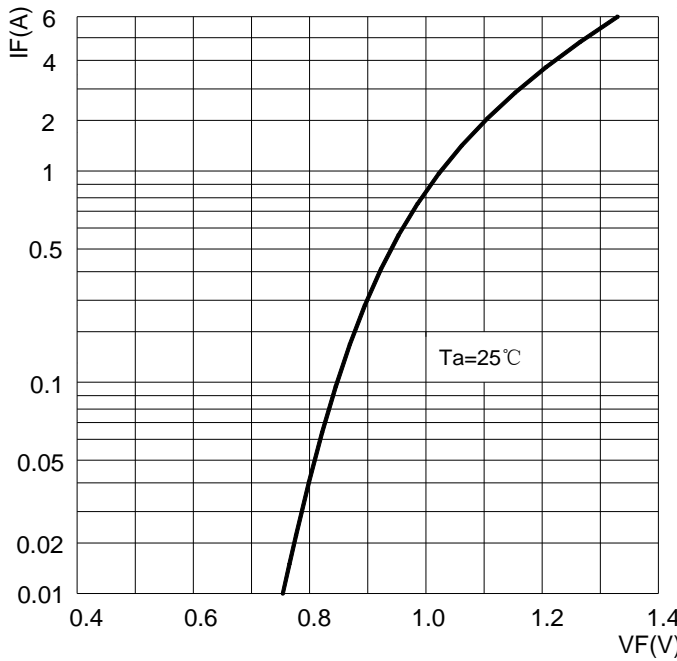

FIG.4: TYPICAL REVERSE CHARACTERISTICS

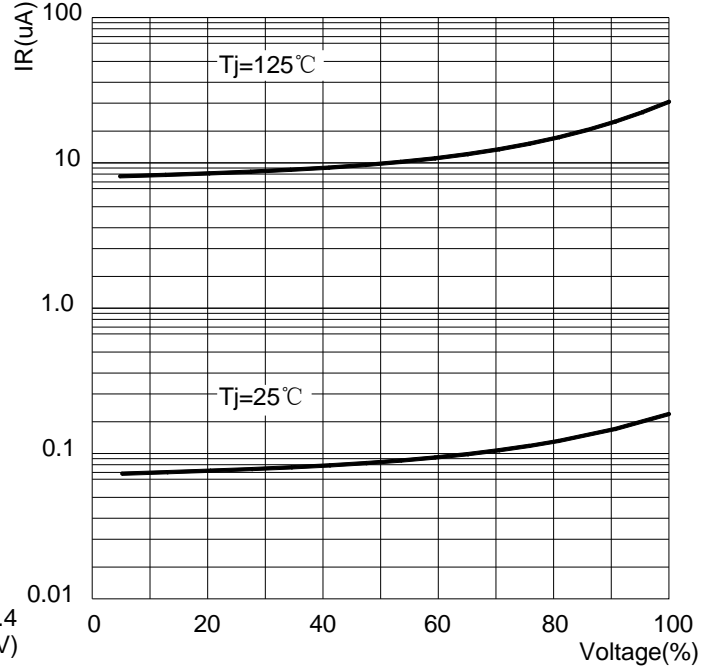
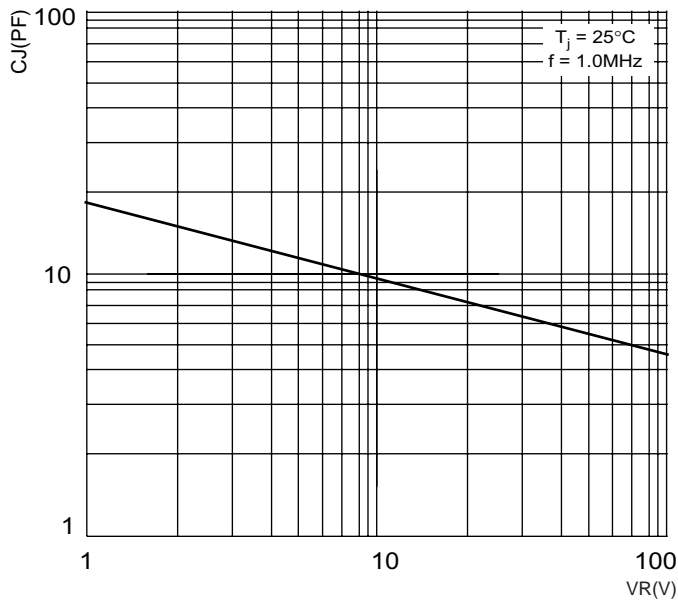
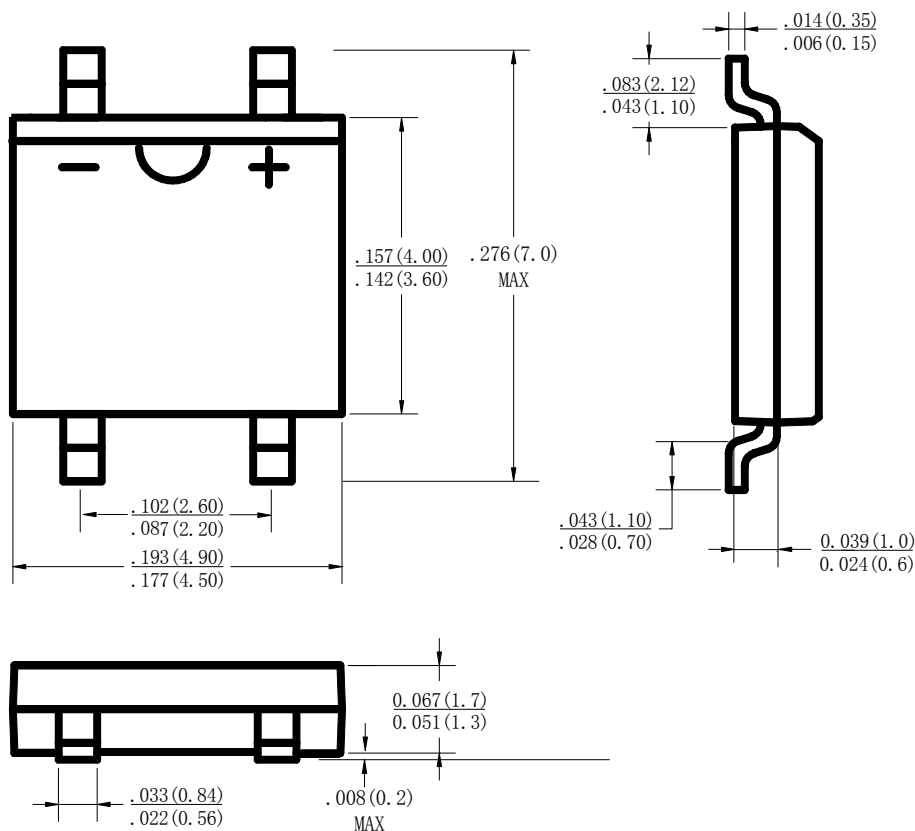

FIG5: Typical Junction Capacitance Per Diode



MBF Package Outline Dimensions



Dimensions in inches and (millimeters)

MBF Suggested Pad Layout

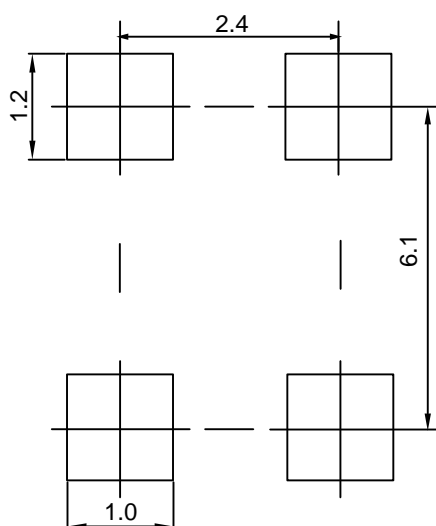

Note:

1. Controlling dimension: in millimeters.
2. General tolerance: ± 0.05 mm.
3. The pad layout is for reference purposes only.

NOTICE

JSCJ reserves the right to make modifications, enhancements, improvements, corrections or other changes without further notice to any product herein. JSCJ does not assume any liability arising out of the application or use of any product described herein.

Reel Taping Specifications For Surface Mount Devices-MBF

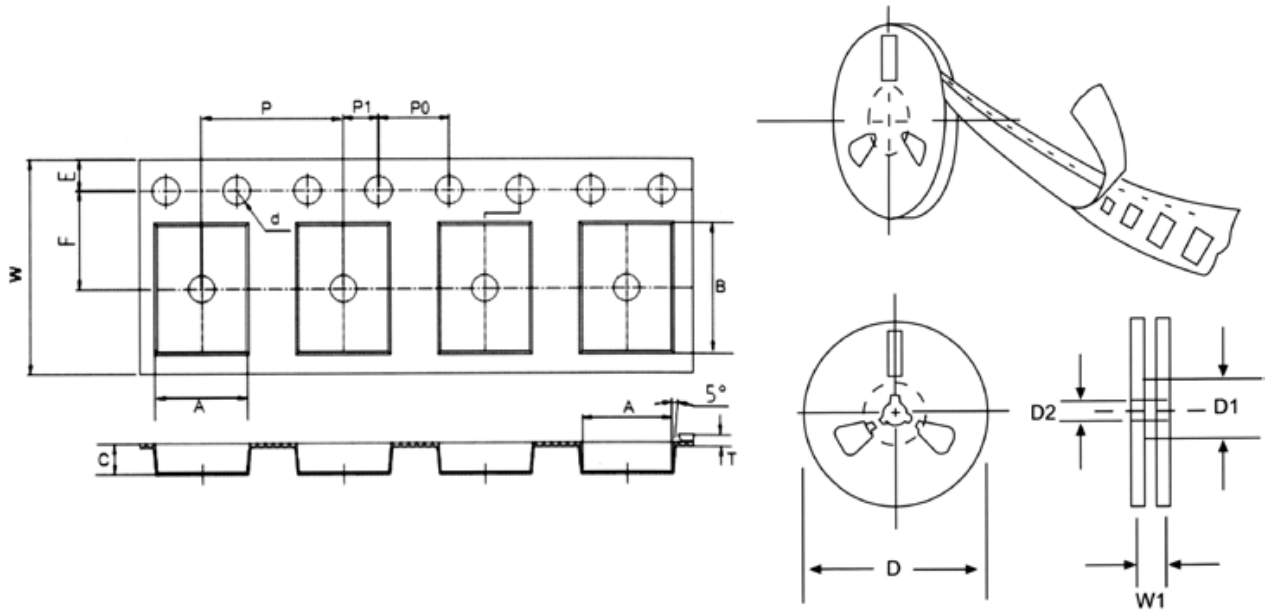

FIG: CONFIGURATION OF SURFACE MOUNTED DEVICES TAPING

ITEM	SYMBOL	MBF mm(inch)
Carrier width	A	5.02+0.1(0.198+0.004)
Carrier length	B	7.15+0.1(0.281+0.004)
Carrier depth	C	1.65+0.1(0.074+0.004)
Sprocket hole	d	1.55±0.05(0.061±0.002)
Reel outside diameter	D	279±2.0 (11± 0.079)
Reel inner diameter	D1	75 ±1.0 (2.95 ±0.039)
Feed hole diameter	D2	13+0.5(0.512+0.020)
Strocket hole position	E	1.75+0.1(0.069+0.004)
Punch hole position	F	5.50+0.1(0.217+0.002)
Punch hole pitch	P	8.0+0.1(0.315+0.004)
Sprocket hole pitch	P0	4.0+0.1(0.157+0.004)
Embossment center	P1	2.0+0.1(0.079+0.004)
Total tape thickness	T	0.20-0.70(0.008-0.028)
Tape width	W	12.0+0.3/-0.1(0.472+0.004)
Reel width	W1	16.8+2.0(0.661+0.079)

NOTE: Devices are packde in accordance with EIA standard RS-481-A and specification given above.