



TO-252-2L Plastic-Encapsulate Transistors

MJD44H11 TRANSISTOR (NPN)

FEATURES

- Designed for General Purpose Amplifier and Low Speed Switching Applications
- DPAK for Surface-Mount Applications
- Low Collector Emitter Saturation Voltage
- High Current

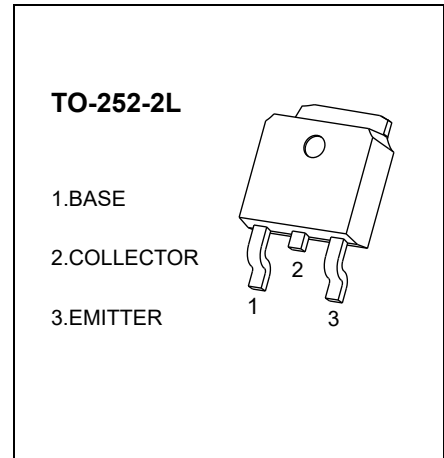

MARKING

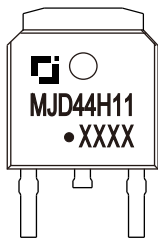

MJD44H11=Device code
 Solid dot=Green moldinn compound device,
 if none,the normal device
 XXXX=Code

Equivalent Circuit

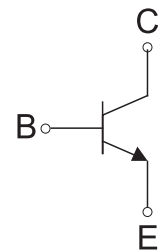

ORDERING INFORMATION

Part Number	Package	Packing Method	Pack Quantity
MJD44H11	TO-252-2L	tape	2500pcs/reel

MAXIMUM RATINGS (Ta=25°C unless otherwise noted)

Symbol	Parameter	Value	Unit
V_{CB}	Collector-Base Voltage	80	V
V_{CE}	Collector-Emitter Voltage	80	
V_{EB}	Emitter-Base Voltage	6	
I_C	Collector Current	8	A
I_{CA}	Peak Collector Current (tp<1ms)	16	A
P_D	Collector Power Dissipation (Ta=25°C) ②	1.8	W
	Collector Power Dissipation (Tc=25°C) ①③	20	W
$R_{\theta JA}$	Thermal Resistance From Junction To Ambient	68	/K
$R_{\theta JC}$	Thermal Resistance From Junction To Encapsulation	6.25	/K
T_{jmax}	MAX Junction Temperature	150	°C
T_{stg}	Operation Junction and Storage Temperature Range	-55~+150	°C

ELECTRICAL CHARACTERISTICS

$T_a=25^\circ\text{C}$ unless otherwise specified

Parameter	symbol	Test conditions	Min	Typ	Max	Unit
Collector-base breakdown voltage	$V_{(BR)CBO}$	$I_C=1\text{mA}, I_E=0$	80			V
Collector-emitter breakdown voltage	$V_{(BR)CEO}^{④}$	$I_C=30\text{mA}, I_B=0$	80			V
Emitter-base breakdown voltage	$V_{(BR)EBO}$	$I_E=1\text{mA}, I_C=0$	6.0			V
Collector cut-off current	I_{CBO}	$V_{CB}=80, I_E=0$			1.0	μA
Collector cut-off current	I_{CEO}	$V_{CE}=60, I_B=0$			1.0	μA
Emitter cut-off current	I_{EBO}	$V_{EB}=6\text{V}, I_C=0$			1.0	μA
DC current gain	$h_{FE(1)}$	$V_{CE}=1\text{V}, I_C=2\text{A}$	60			
	$h_{FE(2)}$	$V_{CE}=1\text{V}, I_C=4\text{A}$	40			
	$h_{FE(3)}$	$V_{CE}=5\text{V}, I_C=1\text{A}$	200		400	
Collector-emitter saturation voltage	$V_{CE(sat)}^{④}$	$I_C=8\text{A}, I_B=0.4\text{A}$			0.8	V
Base-emitter saturation voltage	$V_{BE(sat)}^{④}$	$I_C=8\text{A}, I_B=0.8\text{A}$			1.5	V
Transition frequency	f_T	$V_{CE}=10\text{V}, I_C=100\text{mA}, f=1\text{MHz}$	10			MHz
Delay time	t_d	$V_{CC}=10\text{V}, I_C=5\text{A},$ $I_{B1}=I_{B2}=0.5\text{A}$		21		nS
Rise time	t_r			112		nS
Storage time	t_s			370		nS
Fall time	t_f			82		nS

Notes:

1. Thermal resistance from junction to lead mounted on FR4 PCB double sided copper with mini pad, $T_c=25^\circ\text{C}$.
2. Thermal resistance from junction to ambient mounted on FR4 PCB double sided copper with mini pad, $T_a=25^\circ\text{C}$.
3. $T_c=25^\circ\text{C}$. Limited only by maximum temperature allowed.
4. Pulse Test: Pulse Width $\leq 380\mu\text{s}$, Duty Cycle $\leq 2\%$.

Typical Characteristics

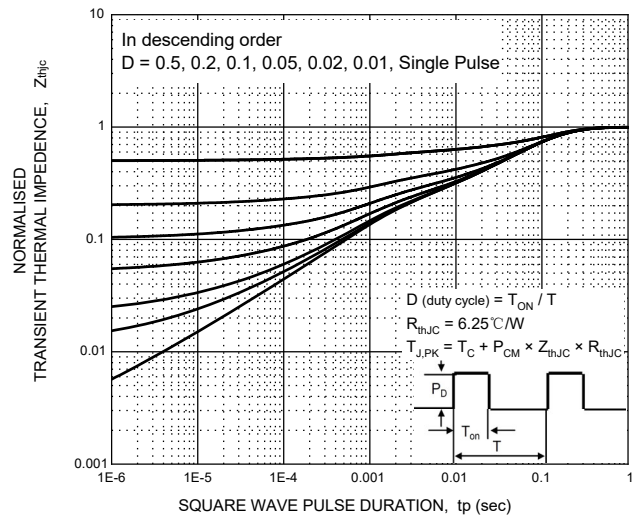
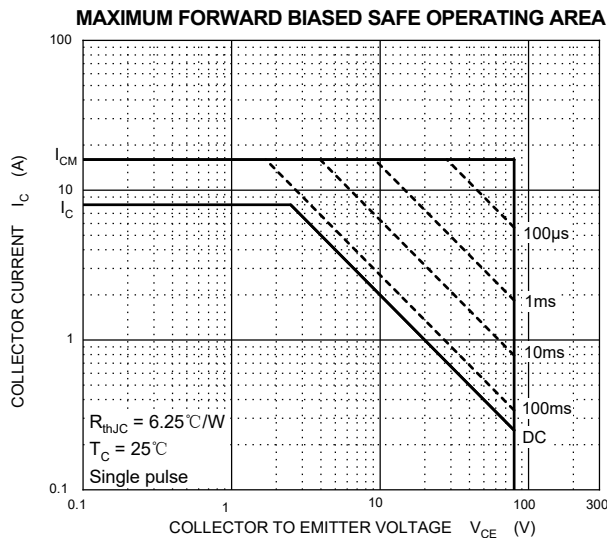
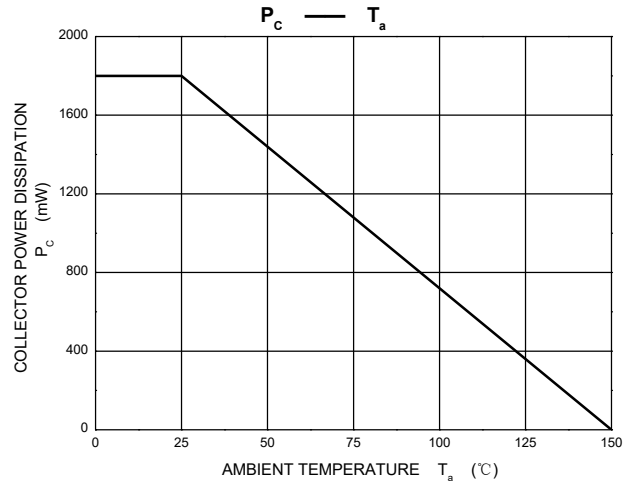
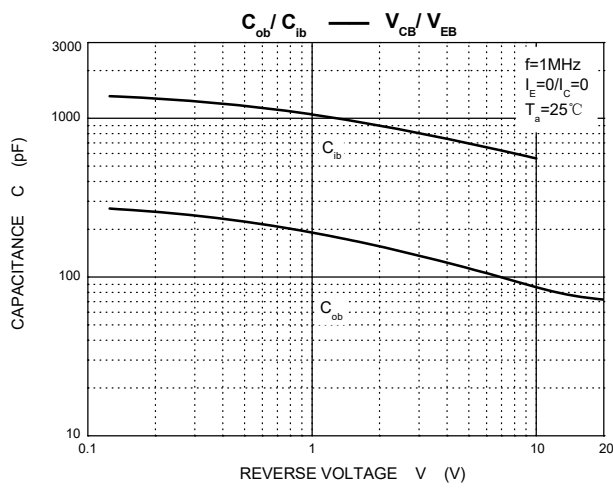
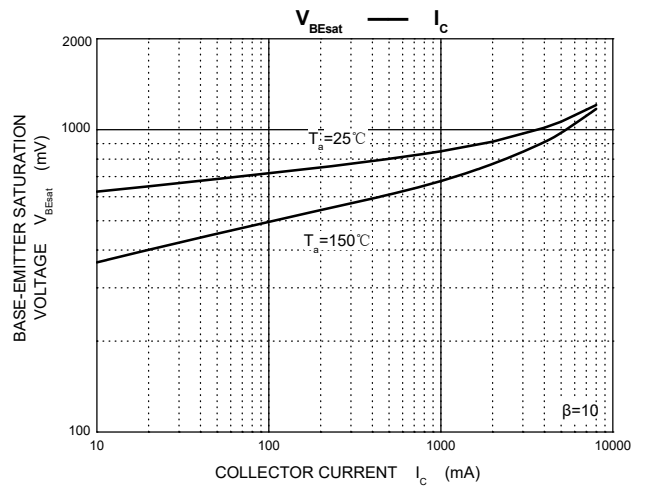
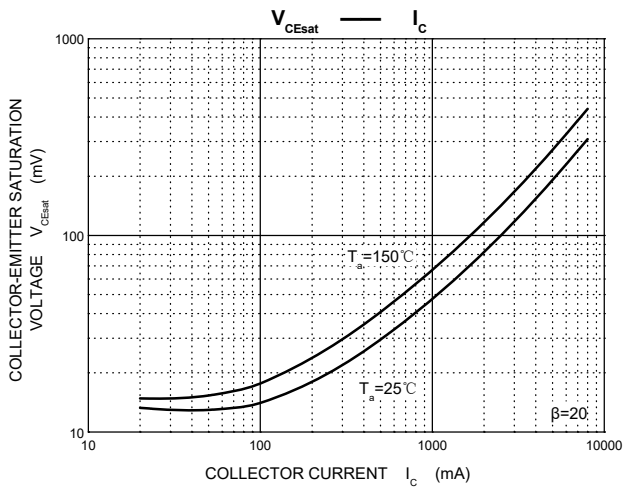
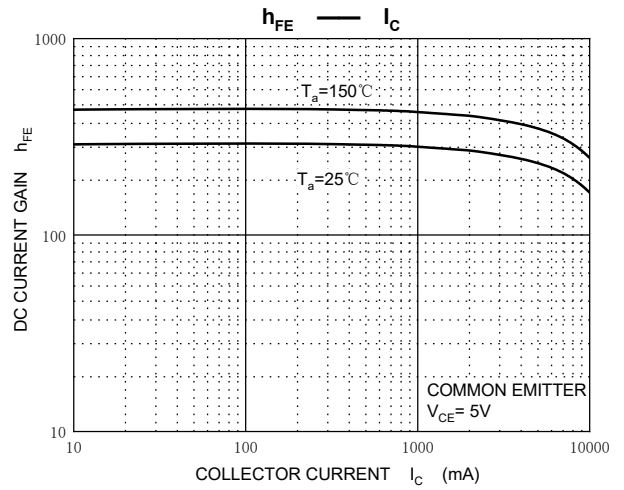
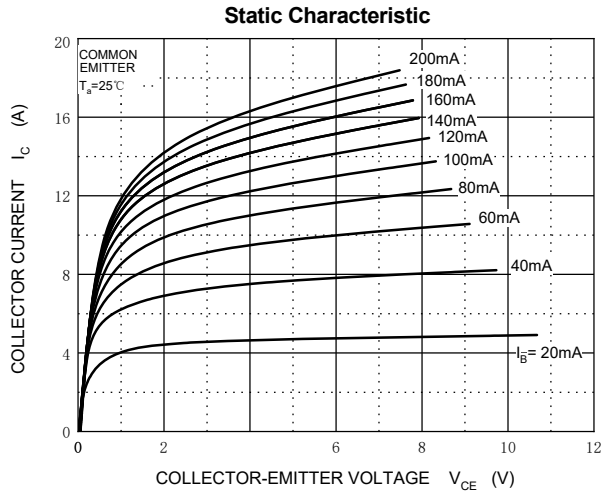

TO-252-2L Package Outline Dimensions

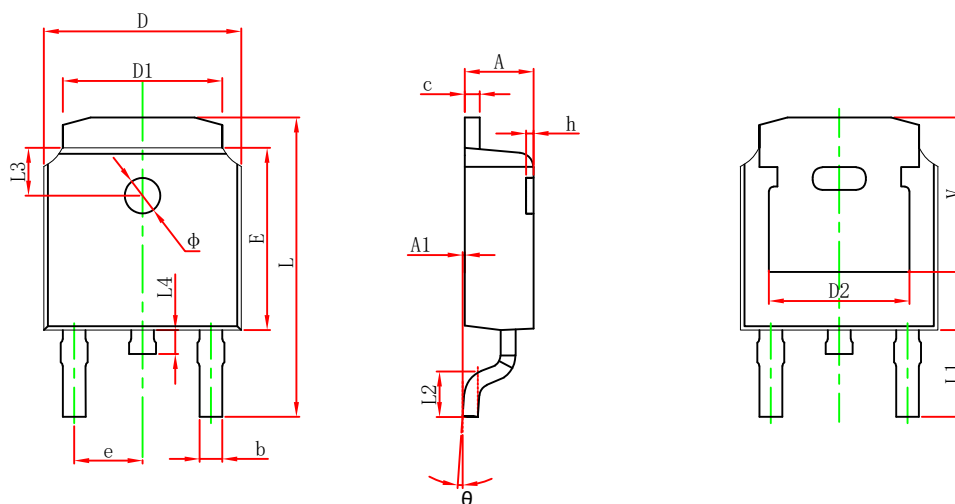

Symbol	Dimensions In Millimeters		Dimensions In Inches	
	Min.	Max.	Min.	Max.
A	2.200	2.400	0.087	0.094
A1	0.000	0.127	0.000	0.005
b	0.635	0.770	0.025	0.030
c	0.460	0.580	0.018	0.023
D	6.500	6.700	0.256	0.264
D1	5.100	5.460	0.201	0.215
D2	4.830 REF.		0.190 REF.	
E	6.000	6.200	0.236	0.244
e	2.186	2.386	0.086	0.094
L	9.712	10.312	0.382	0.406
L1	2.900 REF.		0.114 REF.	
L2	1.400	1.700	0.055	0.067
L3	1.600 REF.		0.063 REF.	
L4	0.600	1.000	0.024	0.039
Φ	1.100	1.300	0.043	0.051
θ	0°	8°	0°	8°
h	0.000	0.300	0.000	0.012
V	5.250 REF.		0.207 REF.	

TO-252-2L Suggested Pad Layout

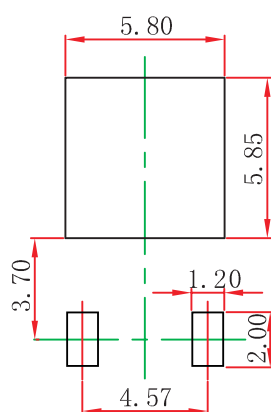

- Note:
1. Controlling dimension: in millimeters.
 2. General tolerance: $\pm 0.05\text{mm}$.
 3. The pad layout is for reference purposes only.

NOTICE

JSCJ reserves the right to make modifications, enhancements, improvements, corrections or other changes without further notice to any product herein. JSCJ does not assume any liability arising out of the application or use of any product described herein.

TO-252-2L Tape and Reel

TO-252-2L Embossed Carrier Tape

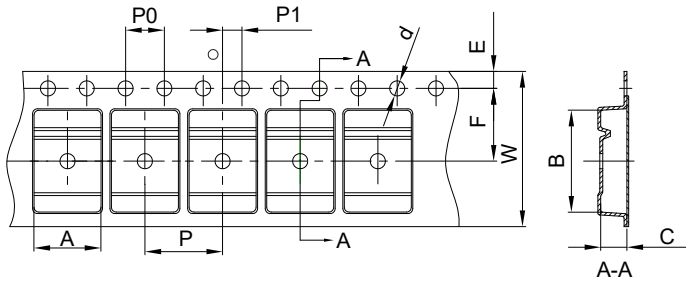

Packaging Description:

TO-252-2L parts are shipped in tape. The carrier tape is made from a dissipative (carbon filled) polycarbonate resin. The cover tape is a multilayer film (Hear Activated Adhesive in nature) primarily composed of polyester film, adhesive layer, sealant, and anti-static sprayed agent. These reeled parts in standard option are shipped with 2500 units per 13" or 33.0 cm diameter reel. The reels are clear in color and is made of polystyrene plastic (anti-static coated).

Dimensions are in millimeter										
Pkg type	A	B	C	d	E	F	P0	P	P1	W
TO-252	6.90	10.50	2.70	Φ1.55	1.75	7.50	4.00	8.00	2.00	16.00

TO-252-2L Tape Leader and Trailer

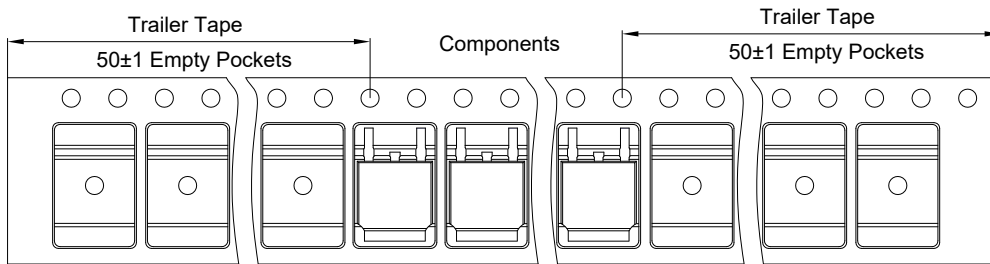

TO-252-2L Reel

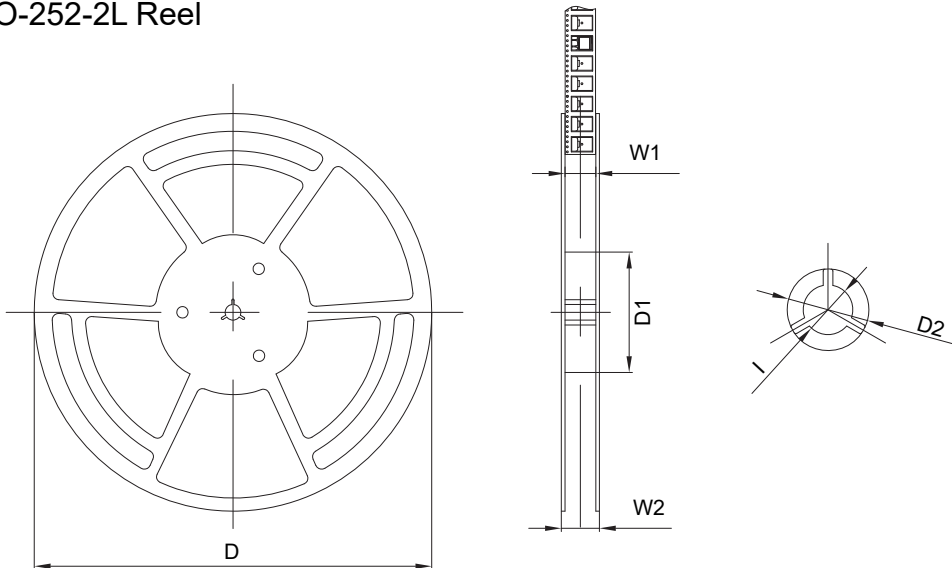

Dimensions are in millimeter						
Reel	D	D1	D2	W1	W2	l
13" Dia	330.00	100.00	Φ21.00	16.40	21.40	Φ13.00

Reel	Reel Size	Box	Box Size(mm)	Carton	Carton Size(mm)
2500 pcs	13 inch	5000 pcs	360×360×65	25000 pcs	378×358×382